

Miniature High Power Relay

SLA-Series

Features

- Miniature relay with high switching capability : 30A.
- Contact form : Form A, Form B or 1Form C.
- Special type of 4000VAC dielectric strength and 6000V surge voltage (1.2/50uS) between coil and contact (DJ, DMJ, DBJ not include Open type) available.
- Sealed type and open type available.
- Patent Number : ZL 2008 20050972.1
- Satisfy IEC60335-1 product is available.
- Satisfy IEC60079-15 product is available.

Safety Approval

UL , C-UL File No. : E190598

TUV File No. : R50143450

CQC File No. : CQC02001002109

VDE File No. : 40036707

Contact Capacity

Model	SLA-DM		SLA -DB	SLA -D
	Standard type/S Mark	Coil Power H&S		
Nominal switching capacity (res. load)	30A 250VAC	20A 250VAC	15A 250VAC	20A/10A 250VAC
Max. switching current	30A	20A	20A	20A
Max. switching voltage	250VAC	250VAC	250VAC	250VAC
Max. switching power	7,500VA	5,000VA	5,000VA	5,000VA

Charateristic Data

Contact material	Silver alloy		
Initial contact resistance (at 6VDC 1A)	50mΩ Max. (1A 6VDC)		
Operate time (at nominal volt.)	15msec. Max.(no diode)		
Release time (at nominal volt.)	10msec. Max.(no diode)		
Initial insulation resistance	100MΩ Min.(DC500V)		
Initial dielectric strength	Between open contacts :	Standard Type:AC1,500V , 50/60Hz 1min.	
		Mark H & S:AC2,000V, 50/60Hz 1min.	
	Between coil and contact :	AC2,500V , 50/60Hz 1min. (4kV available)	
		AC1,500V , 50/60Hz 1min. (open type available)	
Vibration resistance	Functional	10 ~ 55Hz at double amplitude of 1.5 mm	
	Destructive	10 ~ 55Hz at double amplitude of 1.5 mm	
Shock resistance	Functional	10G Min.	
	Destructive	100G Min.	
Endurance (operations)	Mechanical (at 10,800 ops./h)	10,000,000 cycles (at room temperature)	
	Electrical (at 360 ops./h)	100,000 cycles (at room temperature)	
Ambient temperature	-40°C ~ +105°C (no condensation)		
Unit weight	Open type: Approx.20.0g	Sealed type: Approx. 24.0g	

Coil Data (at 20 °C)

Nominal voltage (VDC)	Nominal operating current 10% (mA)	Coil resistance 10% (Ω)	Max. allowable voltage	Pick-up voltage (Max.)	Drop-out voltage (Min.)	Nominal operating power
5	180.00	27	130 % of nominal voltage	75 % of nominal voltage	5 % of nominal voltage	0.90W
6	150.00	40				
9	100.00	90				
12	75.00	160				
15	60.00	250				
18	50.00	360				
24	37.50	640				
48	18.75	2,560				
110	8.20	13,400				

Coil Data of H mark (at 20°C)

Nominal voltage (VDC)	Nominal operating current 10% (mA)	Coil resistance 10% (Ω)	Max. allowable voltage	Pick-up voltage (Max.)	Drop-out voltage (Min.)	Nominal operating power
6	183.33	33	130 % of nominal voltage	75 % of nominal voltage	5 % of nominal voltage	1.1W
12	91.67	131				
24	45.83	524				
48	22.92	2095				

Coil Data of S mark (at 20°C)

Nominal voltage (VDC)	Nominal operating current 10% (mA)	Coil resistance 10% (Ω)	Max. allowable voltage	Pick-up voltage (Max.)	Drop-out voltage (Min.)	Nominal operating power
6	266.67	22.5	130 % of nominal voltage	75% of nominal voltage	5% of nominal voltage	1.6W
12	133.33	90				
24	66.67	360				
48	33.33	1440				

Safety Approval Ratings

(Note:More detail of approval ratings,please refer to the safety certification)

Approval	CQC	TUV	UL/CUL	VDE
File No.	CQC02001002109	R50143450	E190598	40036707
Approved ratings	Form A : 30A 250VAC Form B : 15A 250VAC Form C : 20A/10A 250VAC	Form A : 30A 240VAC Making: 80A 250VAC(300ms) Breaking:20A 250VAC Form B : 15A 240VAC Form C : 20A/10A 240VAC	Form A: 30A 240VAC, Resistive/General Use 15A 240VAC 1-1/2HP 240VAC;3/4 HP 120VAC TV-8 120VAC 30A 120VAC, Resistive/General Use Pilot duty: 470 VA, 240VAC Electronic Ballast: 10A 277VAC /120VAC Form B: 30A 120VAC, General Use 20A 240VAC, General Use 20A 120VAC, Resistive 10A 240VAC, Resistive/General Use Pilot duty: 275VA, 240VAC Electronic Ballast: 5A, 277VAC/120VAC 1/2HP 240VAC;1/4HP 120VAC Form C: N.O. N.C. 30A 240/120VAC,Resistive 30A 240/120VAC,General Use 20A 240/120VAC, Resistive 20A 240VAC, Resistive 20A 240/120VAC,General Use 10A 240VAC, Resistive 10A 240VAC, Resistive 1-1/2HP 240VAC 1/2HP 240VAC 3/4HP 125/120VAC 1/4HP 125/120VAC TV-8 120VAC TV-3 120VAC 20A 240VAC, General Use 10A 240VAC, General Use Pilot Duty: 470VA 240VAC Pilot Duty: 275VA 240VAC Electronic Ballast: Electronic Ballast: 10A 277VAC/120VAC 5A 277VAC/120VAC	30A 250VAC,NO 20A 250VAC,CO(test NO) 10A 250VAC,CO(test NC)

- (1) The above-mentioned unspecified temperature ratings, means that the ambient temperature is room temperature.
- (2) Only some typical ratings are listed above. Each rating's test condition is different, so the electrical endurance will be different. If more details are required, please contact us.
- (3) For sealed type testing, please open the ventilation hole of case before test.

Ordering Information

Nomenclature										
SLA	-S	-1	12	D	M	J	1	-F	-XX	
Special Parameter : Nil-Standard type, Letter or number-Special resquirement										
Insulation System : Nil-Standard, B-Class B, F-Class F										
Contact Material : Nil-AgSnO ₂ , 1-AgCdO										
Terminal Type : Nil-Standard, J-Without 6# terminal										
Contact Form : Nil-Form C, B-Form B, M-Form A										
Coil Power : D-0.90W,H-1.1W,1.5GAP,S-1.6W,1.5GAP										
Coil Voltage (VDC) : 05, 06, 09, 12, 15, 18, 24, 48, 110										
Number of Poles : 1-1 Pole										
Protective Construction : Nil-Open type, S-Flux proofed, SH-Sealed type washable										
Type Designation : SLA										

Note:1.1W , 1.5GAP and 1.6W,1.5GAP are not suitable for B/C type .

Outline Dimensions, Wiring Diagram, P.C. Board Layout (unit : mm)

Open type

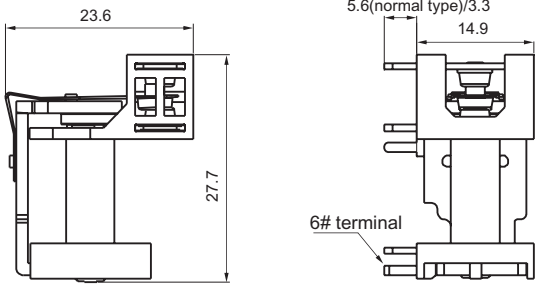

Unless otherwise specified :
 If dimension < 1mm, tolerance : 0.2 mm;
 If dimension 1~5mm, tolerance : 0.3 mm;
 If dimension > 5mm, tolerance : 0.4 mm.
 Note : 1. Extended terminal dimension is dimension before soldering.
 2. Tolerance of P.C.B. layout : 0.1 mm.

Sealed type

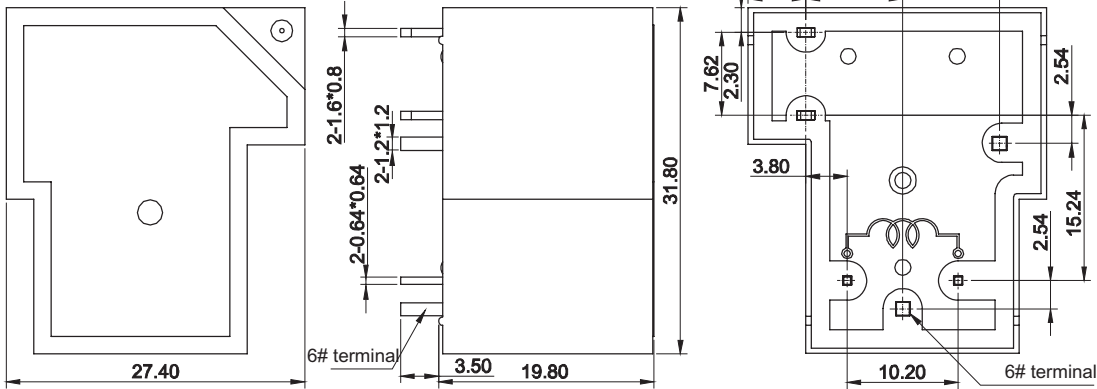

bottom view

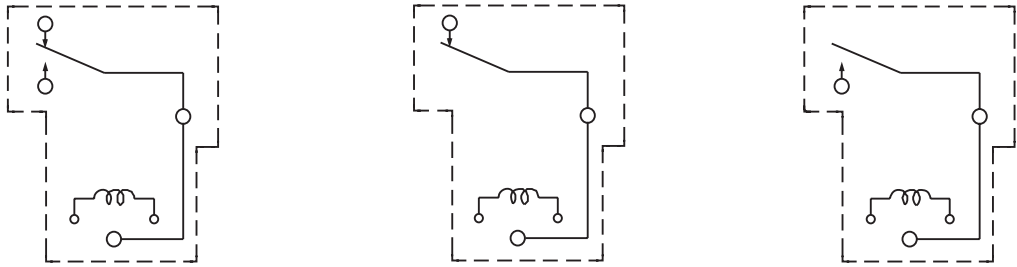

1c 1b 1a

Wiring Diagram (bottom view)

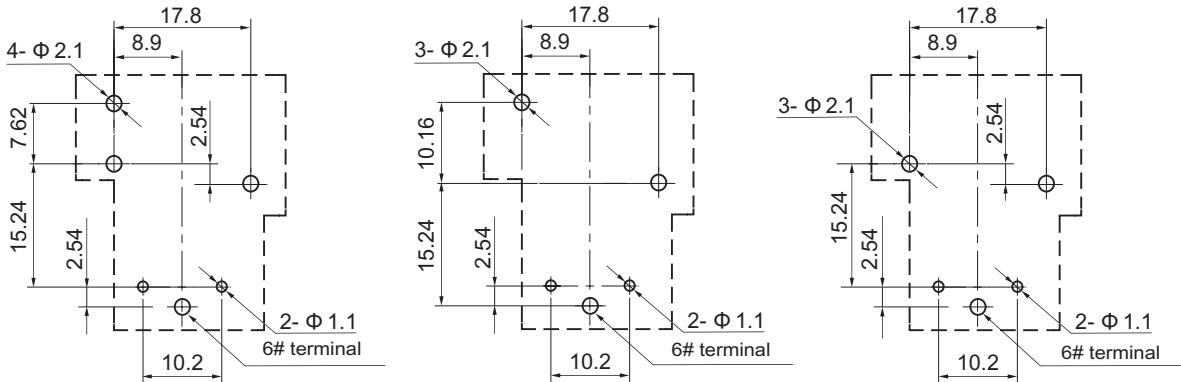

1c 1b 1a

P.C.B. Layout (bottom view)

Typical Applications

- Car
- Air conditioner
- Heater and ventilation equipment
- Home appliances

Characteristic Curves

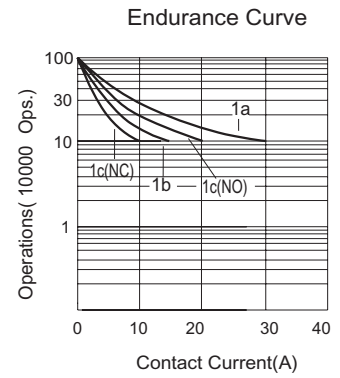
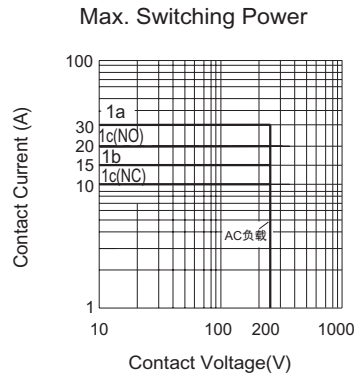
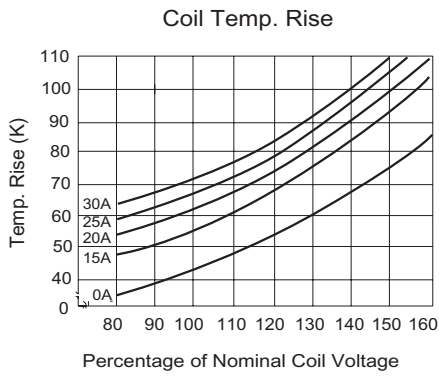

Note: If you choose the sealed type, before using, please remove the convex platform at the top of the case to ensure the normal performance of the relay after the completion of a PCB operations. they are as shown in the following diagram:

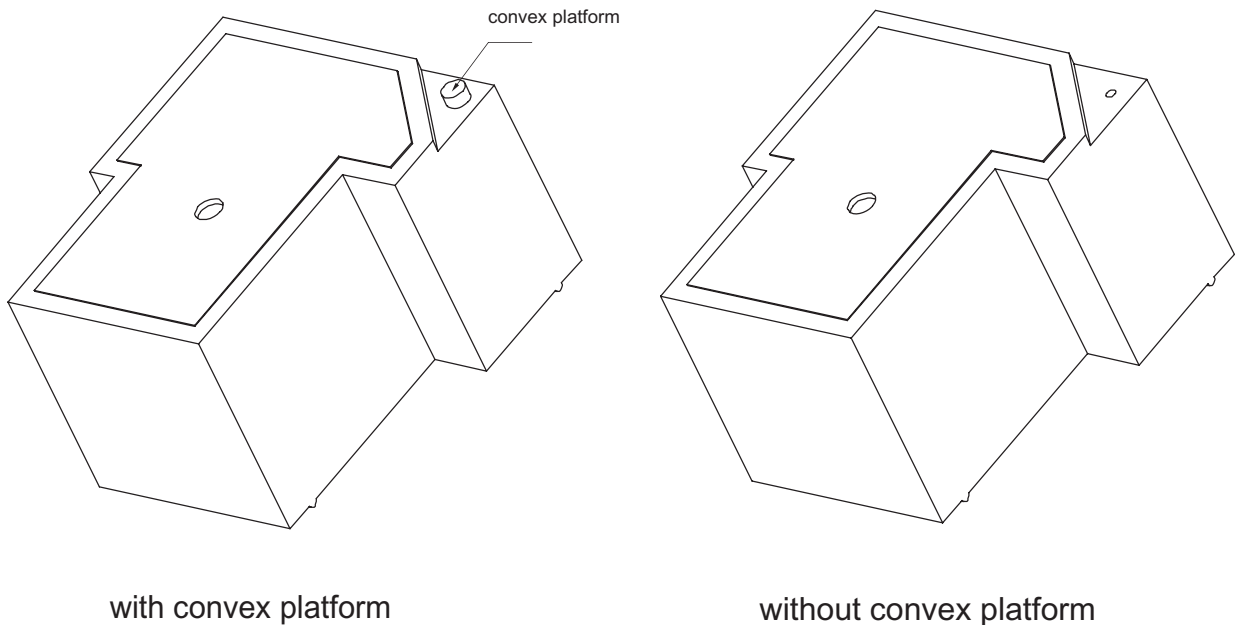

Disclaimer:

This datasheet is the customers' reference. All the specification are subject to change without notice. We could not evaluate all the performance and all the parameters for every possible application. Thus the user should in a right position to choose the suitable product for their own application. For sealed relays after installation and cleaning, please open the vent hole on the case before use. If there is any query, please contact Sanyou for the technical service. However it is the user's responsibility to determine which product should be used only.