

<b>SURFACE MOUNT RECTIFIERS</b>	<b>REVERSE VOLTAGE:1300-2000V</b> <b>CURRENT: 1.0 A</b>
---------------------------------	--

**FEATURES**

- Glass passivated device
- Ideal for surface mouted applications
- Low leakage current
- Metallurgically bonded construction

**MECHANICAL DATA**

Case:JEDEC DO-213AB,molded plastic over passivated chip

Terminals:Solder Plated, solderable per MIL-STD-750, Method 2026

Polarity: Color band denotes cathode end

Weight: 0.0046 ounces, 0.116 gram

Mounting position: Any

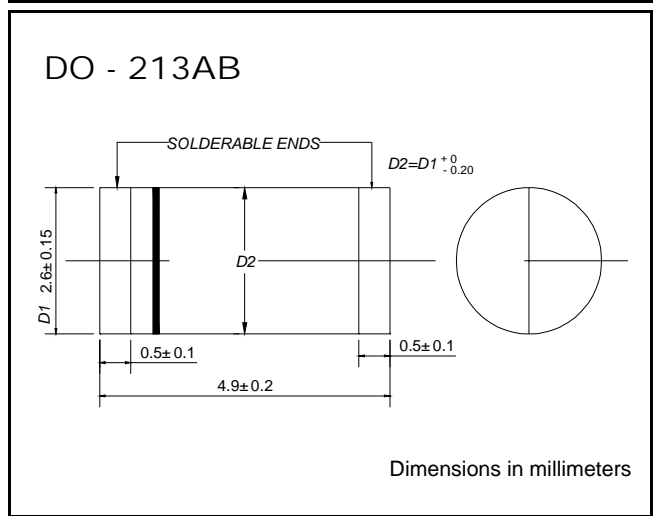

**MAXIMUM RATINGS AND ELECTRICAL CHARACTERISTICS**

Ratings at 25 ambient temperature unless otherwise specified.  
Single phase,half wave,60Hz,resistive or inductive load.For capacitive load,derate current by 20%.

		SM 513	SM 516	SM 518	SM 2000	UNITS
Maximum recurrent peak reverse voltage	$V_{RRM}$	1300	1600	1800	2000	V
Maximum RMS voltage	$V_{RMS}$	910	1120	1260	1400	V
Maximum DC blocking voltage	$V_{DC}$	1300	1600	1800	2000	V
Maximum average forward rectified current $T_A=75$	$I_{(AV)}$	1.0				A
Peak forward surge current 8.3ms single half-sine-wave superimposed on rated load (JEDEC method)	$I_{FSM}$	40				A
Maximum forward voltage at 1.0A	$V_F$	1.1				V
Maximum DC reverse current @ $T_A=25$ at rated DC blockjng voltage @ $T_A=125$	$I_R$	5.0 50				$\mu A$
Typical junction capacitance (NOTE 1)	$C_j$	15				pF
Typical thermal resistance (NOTE 2)	$R_{j\theta L}$	20				/W
Typical thermal resistance (NOTE 3)	$R_{j\theta A}$	50				/W
Operating temperature range	$T_j$	- 55 --- + 175				
Storage temperature range	$T_{STG}$	- 55 --- + 175				

NOTES:1. Measured at 1.0MHz and applied average voltage of 4.0V DC.  
2. Thermal resistance junction to lead, 6.0 mm<sup>2</sup> copper pads to each terminal.  
3. Thermal resistance junction to ambient, 6.0 mm<sup>2</sup> copper pads to each terminal.

**FIG. 1 - TYPICAL FORWARD CURRENT DERATING CURVE**

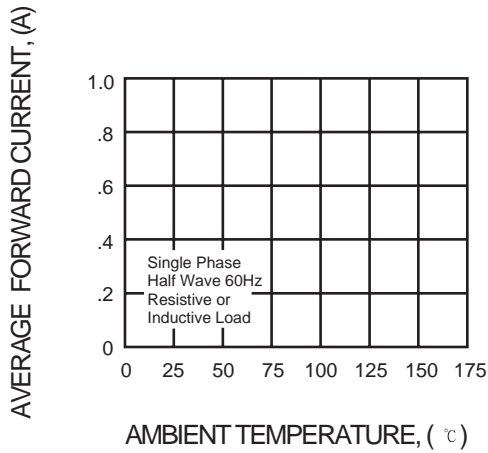

**FIG. 2 - MAXIMUM NON-REPETITIVE FORWARD SURGE CURRENT**

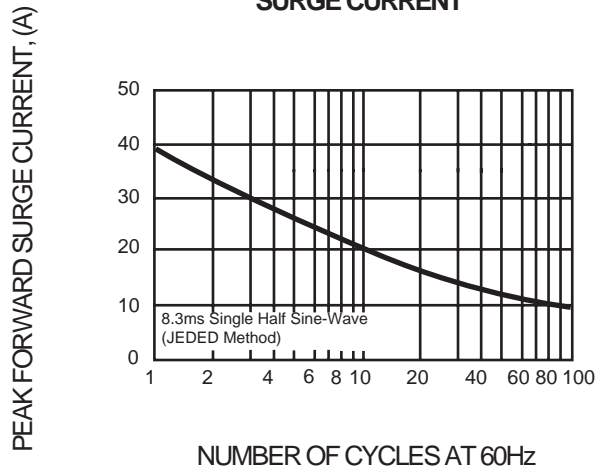

**FIG. 3 - TYPICAL INSTANTANEOUS FORWARD CHARACTERISTICS**

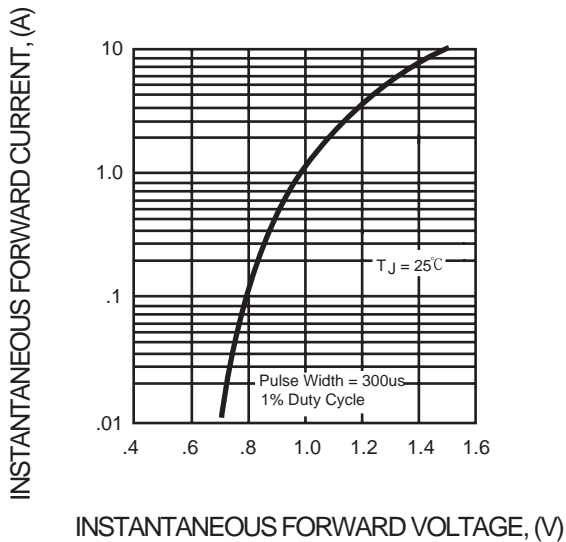

**FIG. 4 - TYPICAL REVERSE CHARACTERISTICS**

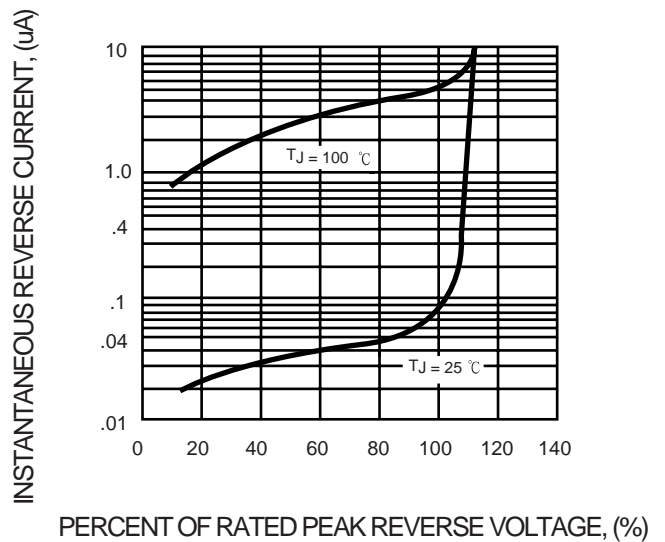

**FIG. 5 - TYPICAL JUNCTION CAPACITANCE**

