

SMDA05C-8 THRU SMDA24C-8

SURFACE MOUNT DIODE ARRAY TRANSIENT VOLTAGE SUPPRESSOR

Stand-off Voltage - 5.0 to 24 Volts Peak Pulse Power - 300 Watts

SO-14/MS-012-AB

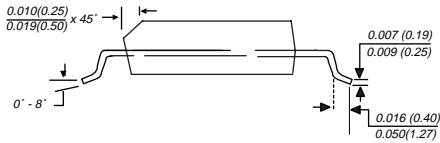
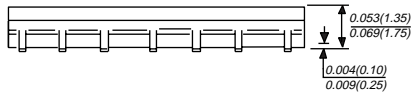
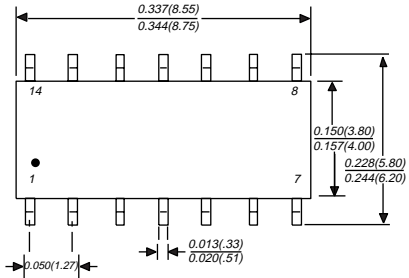

Dimensions in inches and (millimeters)

FEATURES

- ◆ Plastic package has Underwriters Laboratory Flammability Classification 94V-0
- ◆ Offers ESD protection in accordance with IEC1000-4-2 (IEC801-2)
- ◆ Monolithic TVS junctions
- ◆ 300W peak pulse power surge capability
- ◆ Excellent clamping capability
- ◆ Protection of up to eight data lines
- ◆ Fast response time: typically less than 5.0ns from 0 volts to $V_{(BR)}$
- ◆ High temperature soldering guaranteed: 265°C for 5 seconds at terminals



MECHANICAL DATA

Case: JEDEC MS-012-AB molded plastic, over passivated junctions

Terminal: Plated, solderable per MIL-STD-750, Method 2026

Polarity: Bidirectional as marked

Mounting Position: Any

Weight: 0.07 ounce, 1.75 grams

MAXIMUM RATINGS AND ELECTRICAL CHARACTERISTICS

Ratings at 25°C ambient temperature unless otherwise specified.

RATING	SYMBOL	VALUE	UNITS
Peak power dissipation with a 8.0/20μs waveform (NOTE 1, FIG 1)	PPPM	Minimum 300	Watts
Peak power pulse current with a 8.0/20μs waveform (NOTE 1)	IPPM	20.0 15.0 12.0 7.5	Amps
Operating junction and storage temperature range	T_J, T_{STG}	-50 to +125	°C

NOTES:

- (1) Non-repetitive current pulse, per Fig.3 and derated above $T_A=25^\circ\text{C}$ per Fig. 2
- (2) Mounted on copper pad areas of 0.045 x 0.030" (1.14 x 0.076mm) per leg

BIDIRECTIONAL APPLICATIONS

All electrical characteristics apply in both directions

ELECTRICAL CHARACTERISTICS at 25°C

PART NUMBER	DEVICE MARKING CODE	STAND-OFF VOLTAGE	MINIMUM BREAKDOWN VOLTAGE at $I_T=1.0\text{mA}$ (NOTE 1)	MAXIMUM CLAMPING VOLTAGE at $I_{PP} = 1\text{A}$	MAXIMUM CLAMPING VOLTAGE at $I_{PP} = 5\text{A}$	MAXIMUM REVERSE LEAKAGE CURRENT at V_{WM}	MAXIMUM JUNCTION CAPACITANCE (NOTE 3)
BIDIRECTIONAL		V_{WM} Volts	$V_{(BR)}$ Volts	V_C (NOTE 2) Volts	V_C (NOTE 2) Volts	I_D μA	C_J pF
SMDA05C-8	SEB	5.0	6.0*	9.8	11.0	100.0	350
SMDA12C-8	SED	12.0	13.4	19.0	24.0	1.0	150
SMDA15C-8	SEF	15.0	16.7	24.0	30.0	1.0	120
SMDA24C-8	SEH	24.0	26.7	43.0	55.0	1.0	100

NOTES:

- (1) $V_{(BR)}$ measured at pulse width of 300 μs sq. wave or equivalent
 - (2) Surge current waveform per Fig. 3 and derate per Fig. 2
 - (3) Junction capacitance measured at 1.0 MHz and applied $V_R=0$ volts
- * $V_{(BR)}$ test current (I_T) is 10 mA

*Application note: Due to the topology of the SMDA array the V_{RWM} and $V_{(BR)}$ specifications also apply to the differential voltage between any two data line pins. Hence the SMDA12C-8 is designed to "see" a maximum voltage excursion of ± 6 volts between any two data lines.

CIRCUIT DIAGRAM* - top view

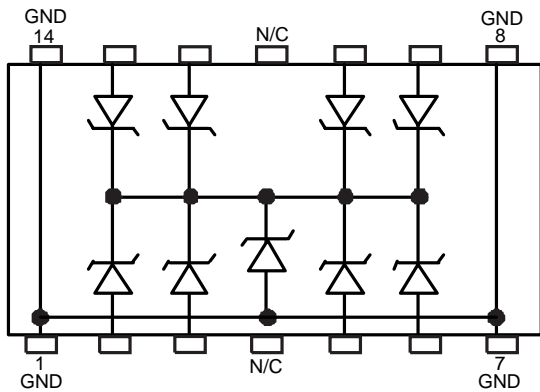

*SMDA05C-8 is common anode configuration

SOLDER PAD GEOMETRY

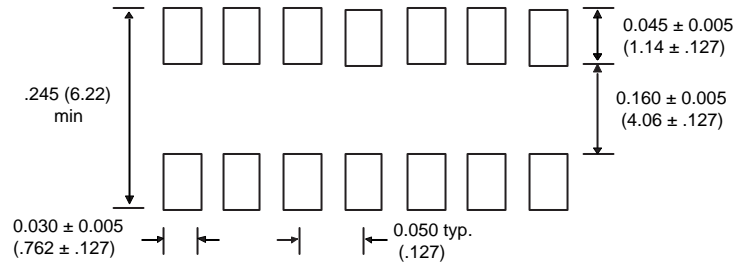

Dimensions in inches and (millimeters)

RATING AND CHARACTERISTIC CURVES FOR SMDA05C-8 THRU SMDA24C-8

