



Data Sheet

USB Two Channel Audio Controller

SN11113

DATA SHEET

SN11113

USB Two Channel Audio Controller

Revision 1.1

Copyright ©2003, Sonix Technology Co., Ltd.
All rights reserved.





I. Description

SONiX SN11113 is an USB audio controller. It supports 32KHz, 44.1KHz and 48KHz sampling rate in digital playback and recording; 44.1KHz and 48 KHz sampling rate in analog audio playback and recording.

In digital playback mode, it receives audio stream from PC via USB interface and transmits audio data according to the AES/EBU, IEC60958, S/PDIF consumer interface standards. In analog playback mode, it supports AC 97 Codec for analog playback.

In digital recording mode, it receives S/PDIF digital audio input and sends back to PC through USB. Three sampling rates; includes 32 KHz, 44.1 KHz, and 48 KHz; are automatically locked internally. In analog recording mode, 44.1KHz and 48 KHz sampling rate are supported by analog audio recording.

Totally one control pipe, two isochronous pipes, and one interrupt pipe are supported by SN11113.

II. Ordering information

SN11113F : 64-pin LQFP (10x10x1.4 mm)

III. Block diagram

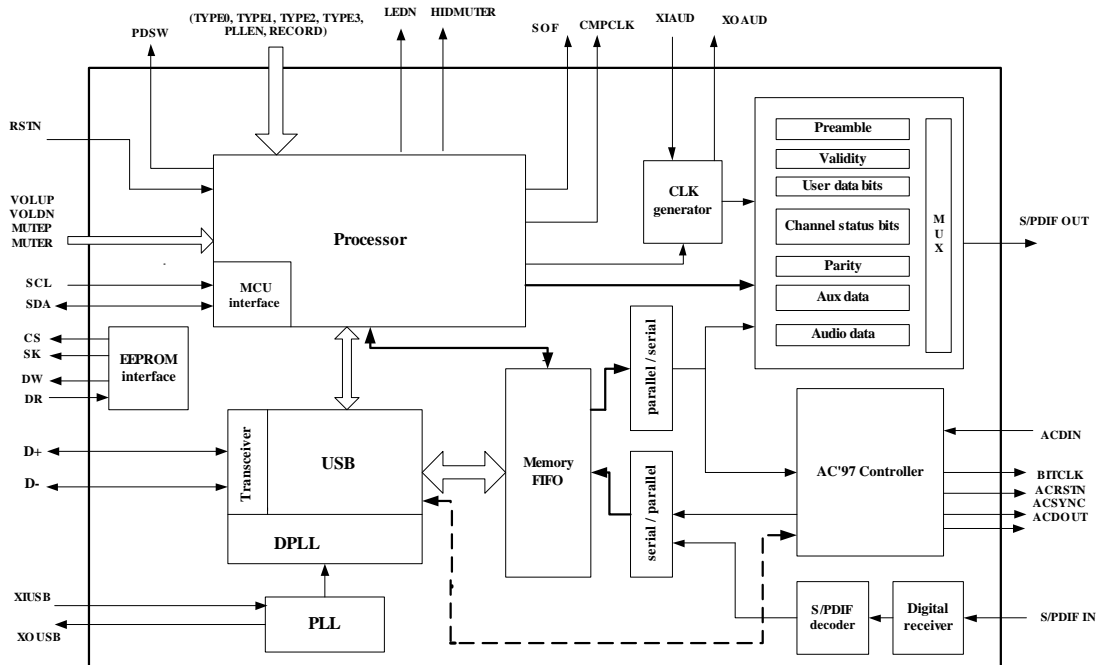

IV. Pin description

4.1 SN11113 pin chart (64-pin LQFP)

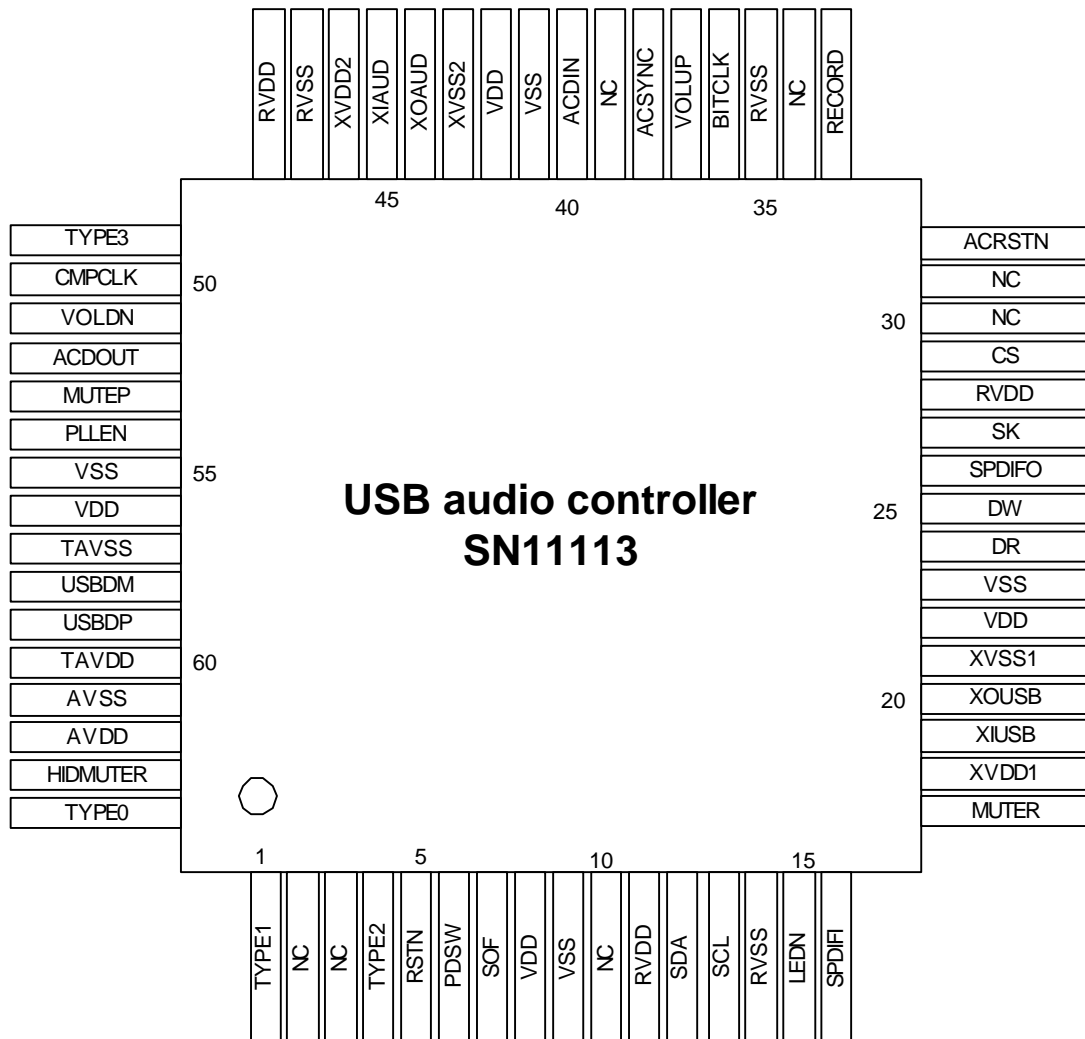

4.2 pin assignment and description (64-pin LQFP)

Pin No.	Pin Name	Pin Type	Description
1	TYPE1	I, ST	Product type setting pin1
2	NC		
3	NC		
4	TYPE2	I, ST	Product type setting pin2
5	RSTN	I, ST, PU	System reset pin, pull low to reset
6	PDSW	O, 4mA, SR	Power down switch control -- 0: normal mode, 1: power down mode
7	SOF	O, 4mA, SR	USB SOF (Start of Frame) pin provides 1KHz signal
8	VDD	P	Power pin
9	VSS	P	Power pin



10	NC		
11	RVDD	P	Power pin for pad
12	SDA	I/O, 4mA, SR	Two wire serial port data pin for external MCU control
13	SCL	I, ST	Two wire serial port clock pin for external MCU control
14	RVSS	P	Power pin for pad
15	LEDN	O, 8mA, SR	LED indicator pin, output low after power on reset, toggle during operation
16	SPDIFI	I, ST	Input pin for SPDIF signal
17	MUTER	I, ST	Recording mute, edge trigger with 64ms de-bouncing circuit
18	XVDD1	P	Power pin for USB external crystal
19	XIUSB	I	6 MHz clock osc pin for USB PLL
20	XOUSB	O	6 MHz clock osc pin for USB PLL
21	XVSS1	P	Power pin for USB external crystal
22	VDD	P	Power pin
23	VSS	P	Power pin
24	DR	I, ST	EEPROM data input Fixing this pin to H or L sets USB vendor ID to SONiX USB vendor ID (hex 0C45); PU or PD is used for different product ID
25	DW	O, 4mA, SR	EEPROM data output
26	SPDIFO	O, 8mA, SR	SPDIF data output
27	SK	O, 4mA, SR	EEPROM clock pin
28	RVDD	P	Power pin for pad
29	CS	O, 4mA, SR	EEPROM chip select
30	NC		
31	NC		
32	ACRSTN	O, 4mA, SR	AC' 97 Codec reset
33	RECORD	I, ST	Recording function enable (=1)
34	NC		
35	RVSS	P	Power pin for pad
36	BITCLK	O, 8mA, SR	AC' 97 serial data clock
37	VOLUP	I, ST	Volume up control, edge trigger with 64ms de-bouncing circuit
38	ACSYNC	O, 4mA, SR	AC' 97 Codec sync (48 kHz) signal
39	NC		
40	ACDIN	I, ST	AC' 97 Codec serial data input
41	VSS	P	Power pin
42	VDD	P	Power pin
43	XVSS2	P	Power pin for external crystal
44	XOAUD	O	12.288 MHz Crystal output
45	XIAUD	I, ST	12.288 MHz Crystal input / connected to PLL VCO output
46	XVDD2	P	Power pin for external crystal
47	RVSS	P	Power pin for pad
48	RVDD	P	Power pin for pad
49	TYPE3	I, ST	Product type setting pin3
50	CMPCLK	O, 4mA, SR	PLL comparator input
51	VOLDN	I, ST	Volume down control, edge trigger with 64ms de-bouncing circuit



52	ACDOUT	O, 4mA, SR	AC' 97 Codec serial data
53	MUTE _P	I, ST	Playback mute control pin, edge trigger with 64ms de-bouncing circuit
54	PLLEN	I, ST	Use PLL (=1) or Crystal at XIAUD pin
55	VSS	P	Power pin
56	VDD	P	Power pin
57	TAVSS	P	Power pin for USB transceiver
58	USBDM	I/O	USB data minus
59	USBDP	I/O	USB data plus
60	TAVDD	P	Power pin for USB transceiver
61	AVSS	P	Power pin for PLL
62	AVDD	P	Power pin for PLL
63	HIDMUTER	O, 8mA, SR	Playback mute led indicator
64	TYPE0	I, ST	Product type setting pin0

** All input pin are 5 volt tolerance, TTL level and Schmitt trigger

All output pins are slew rate control

I – input pin , O – output pin, P – power pin, ST – Schmitt trigger, SR – slew rate control, PU/PD – pull up or pull down

V. Application

5.1 Application example

PC or NoteBook

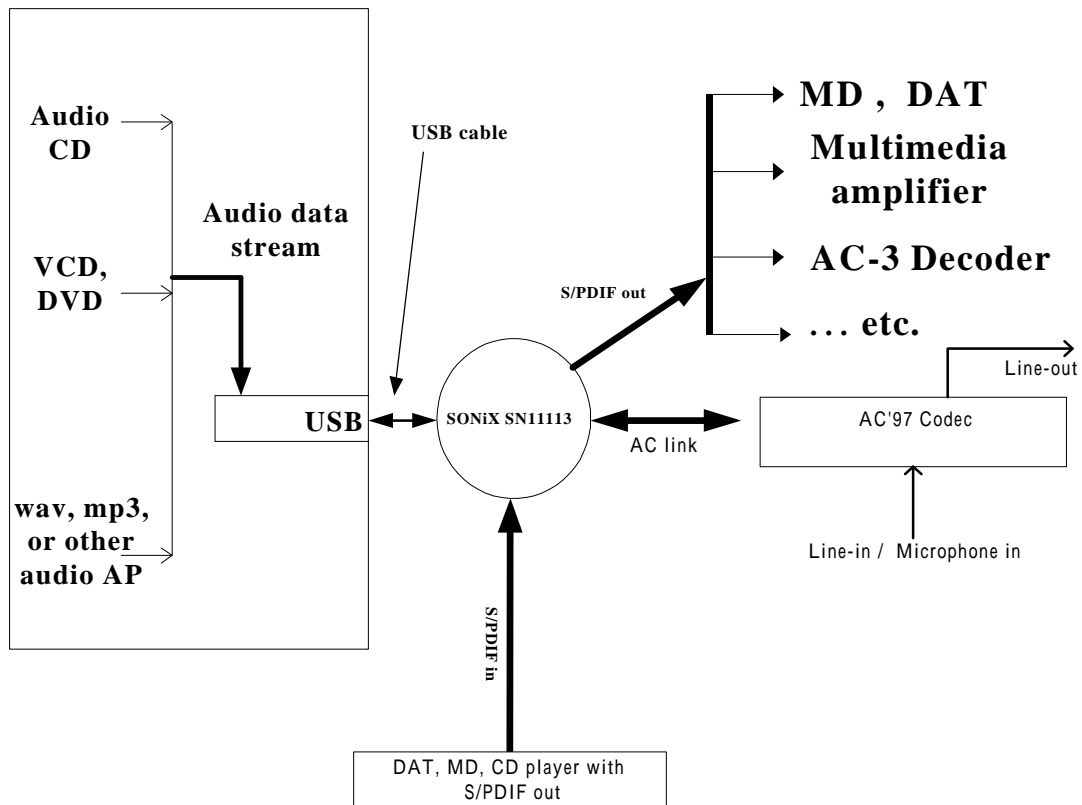

5.2 Brief application circuit chart

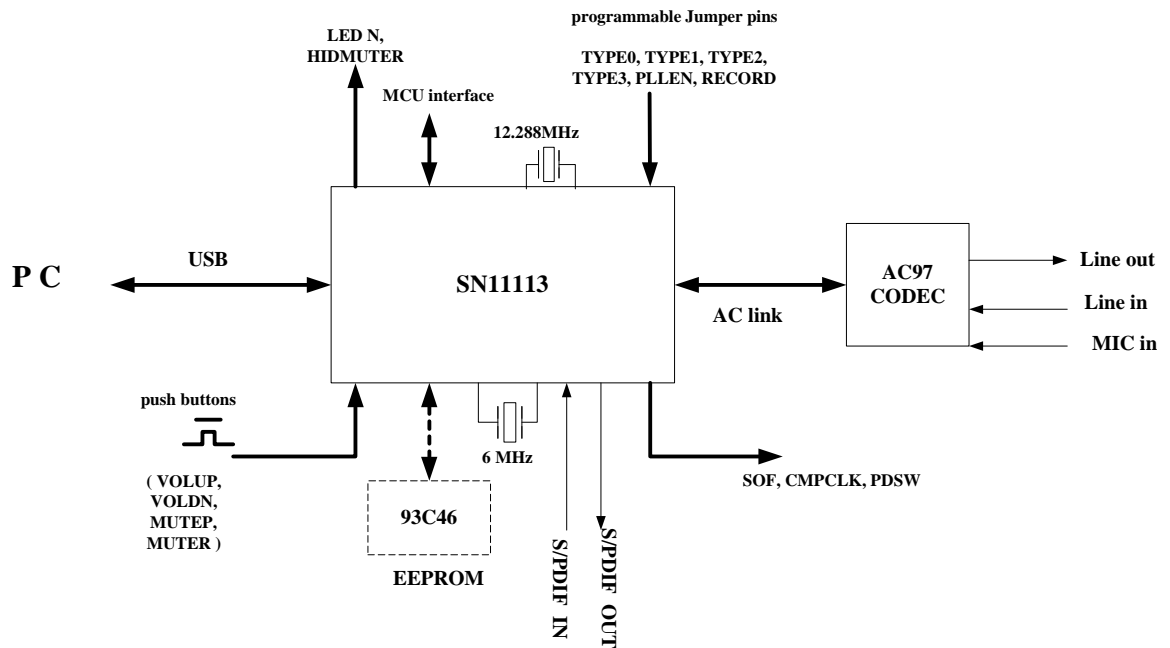

* detail application circuit is available by customer request

VI. Package Specification

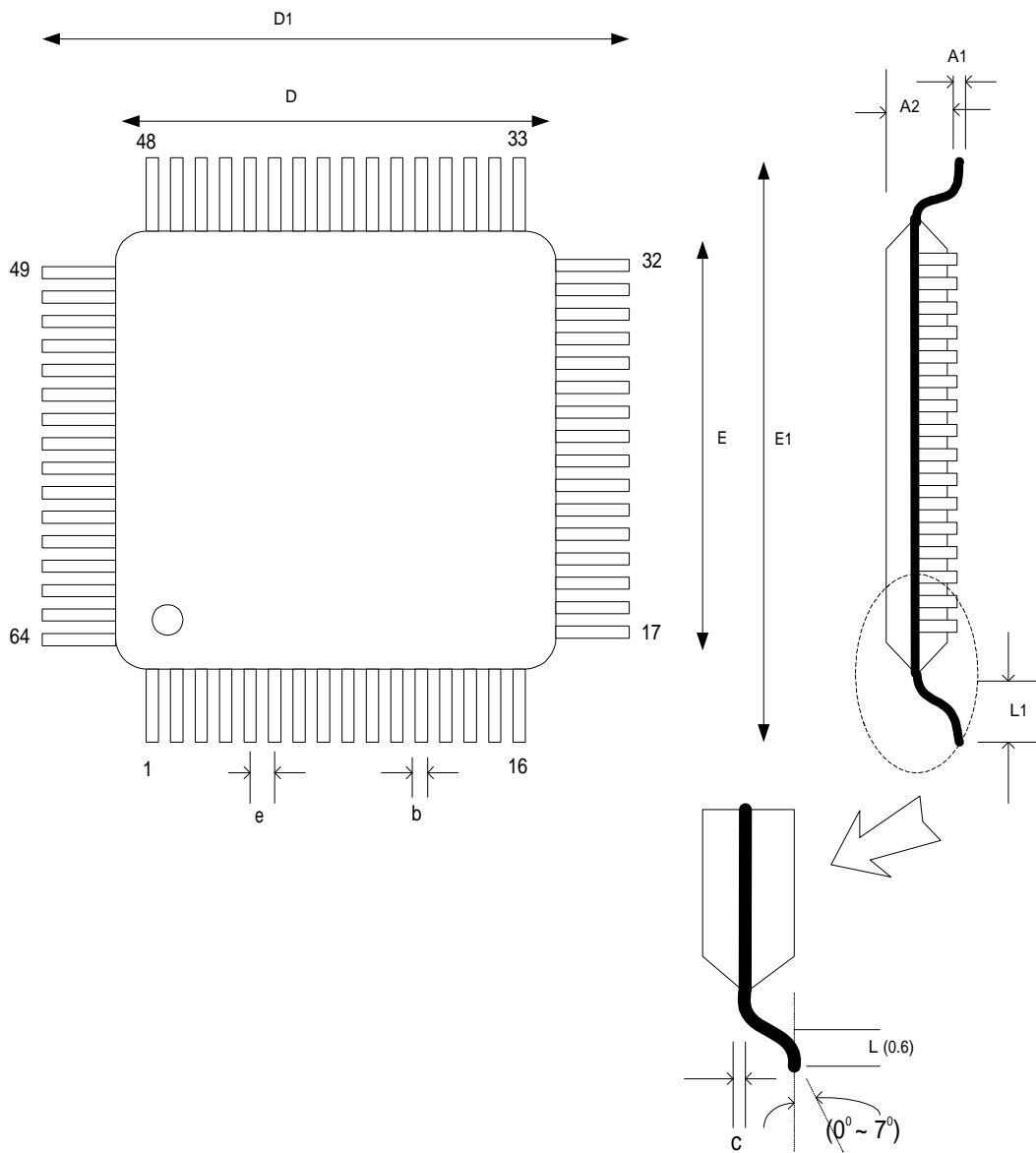

Lead Count	Body Size			
	D	E	D1	E1
64	10.00	10.00	12.00	12.00

Stand-off	Body Thk	Lead Length	Lead Width	Lead Thk	Lead Pitch
A1	A2	L1	b	c	e
0.10	1.40	1.00	0.24	0.125	0.50

Unit : mm



Revision History

<i>Revision</i>	<i>Revision Date</i>	<i>Description of changes</i>
Revision V1.02	Apr. 11, 2003	Initial Release
Revision V1.1	March 19, 2004	Format modification

**DISCLAIMER**

The information appearing in this publication is believed to be accurate. However, this publication could contain technical inaccuracies or typographical errors. The reader should not assume that this publication is error-free or that it will be suitable for any particular purpose. SONiX makes no warranty, express, statutory implied or by description in this publication or other documents which are referenced by or linked to this publication.

In no event shall SONiX be liable for any special, incidental, indirect or consequential damages of any kind, or any damages whatsoever, including, without limitation, those resulting from loss of use, data or profits, whether or not advised of the possibility of damage, and on any theory of liability, arising out of or in connection with the use or performance of this publication or other documents which are referenced by or linked to this publication.

This publication was developed for products offered in Taiwan. SONiX may not offer the products discussed in this document in other countries. Information is subject to change without notice. Please contact SONiX or its local representative for information on offerings available. Integrated circuits sold by SONiX are covered by the warranty and patent indemnification provisions stipulated in the terms of sale only. The application circuits illustrated in this document are for reference purposes only. SONiX DISCLAIMS ALL WARRANTIES, INCLUDING THE WARRANTY OF MERCHANTABILITY OR FITNESS FOR ANY PURPOSE. SONiX reserves the right to halt production or alter the specifications and prices, and discontinue marketing the Products listed at any time without notice. Accordingly, the reader is cautioned to verify that the data sheets and other information in this publication are current before placing orders.

Products described herein are intended for use in normal commercial applications. Applications involving unusual environmental or reliability requirements, e.g. military equipment or medical life support equipment, are specifically not recommended without additional processing by SONiX for such application.

**Contact Information****Main Office**

Address: 9F, No. 8 Lane 32, Hsien Chen 5th St. Chupei City, Hsinchu, Taiwan R.O.C.

Tel: 886-3-551 0520

Fax: 886-3-551 0523

Http:// www.sonix.com.tw

Taipei Office

Address: 15F-2, No. 171, Song Ted Road, Taipei, Taiwan R.O.C.

Tel: 886-2-2759 1980

Fax: 886-2-2759 8180

Hon Kong Office

Address: Flat 3 9/F Energy Plaza 92 Granville Road, Tsimshatsui Ease Kowloon.

Tel: 852-2723 8086

Fax: 852-2723 9179