



# SERIAL-IN PARALLEL-OUT SHIFT REGISTER

The SN54/74LS164 is a high speed 8-Bit Serial-In Parallel-Out Shift Register. Serial data is entered through a 2-Input AND gate synchronous with the LOW to HIGH transition of the clock. The device features an asynchronous Master Reset which clears the register setting all outputs LOW independent of the clock. It utilizes the Schottky diode clamped process to achieve high speeds and is fully compatible with all Motorola TTL products.

- Typical Shift Frequency of 35 MHz
- Asynchronous Master Reset
- Gated Serial Data Input
- Fully Synchronous Data Transfers
- Input Clamp Diodes Limit High Speed Termination Effects
- ESD > 3500 Volts

CONNECTION DIAGRAM DIP (TOP VIEW)

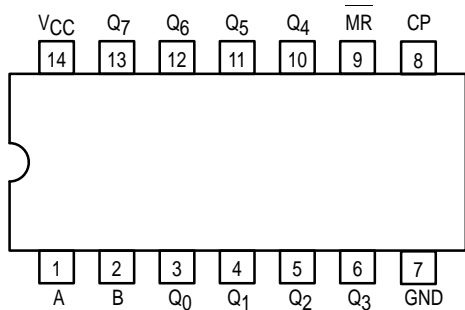

NOTE:  
The Flatpak version has the same pinouts (Connection Diagram) as the Dual In-Line Package.

**PIN NAMES**

A, B	Data Inputs
CP	Clock (Active HIGH Going Edge) Input
MR	Master Reset (Active LOW) Input
Q <sub>0</sub> -Q <sub>7</sub>	Outputs (Note b)

**LOADING (Note a)**

HIGH	LOW
0.5 U.L.	0.25 U.L.
0.5 U.L.	0.25 U.L.
0.5 U.L.	0.25 U.L.
10 U.L.	5 (2.5) U.L.

NOTES:

- a) 1 TTL Unit Load (U.L.) = 40  $\mu$ A HIGH/1.6 mA LOW.  
 b) The Output LOW drive factor is 2.5 U.L. for Military (54) and 5 U.L. for Commercial (74) Temperature Ranges.

## SN54/74LS164

### SERIAL-IN PARALLEL-OUT SHIFT REGISTER LOW POWER SCHOTTKY

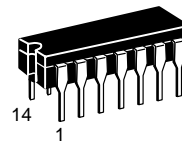

**J SUFFIX**  
CERAMIC  
CASE 632-08

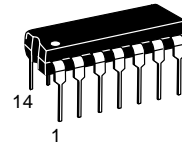

**N SUFFIX**  
PLASTIC  
CASE 646-06

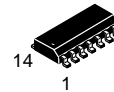

**D SUFFIX**  
SOIC  
CASE 751A-02

**ORDERING INFORMATION**

SN54LSXXXJ Ceramic  
 SN74LSXXXN Plastic  
 SN74LSXXXD SOIC

**LOGIC SYMBOL**

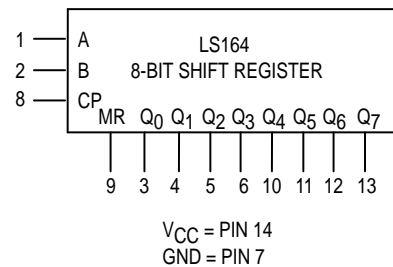

# SN54/74LS164

## LOGIC DIAGRAM

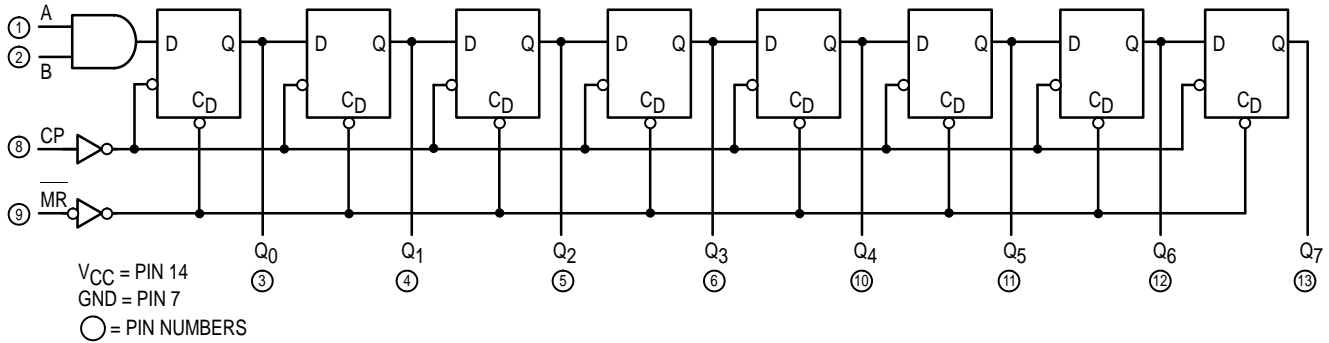

## FUNCTIONAL DESCRIPTION

The LS164 is an edge-triggered 8-bit shift register with serial data entry and an output from each of the eight stages. Data is entered serially through one of two inputs (A or B); either of these inputs can be used as an active HIGH Enable for data entry through the other input. An unused input must be tied HIGH, or both inputs connected together.

Each LOW-to-HIGH transition on the Clock (CP) input shifts data one place to the right and enters into  $Q_0$  the logical AND of the two data inputs ( $A \bullet B$ ) that existed before the rising clock edge. A LOW level on the Master Reset (MR) input overrides all other inputs and clears the register asynchronously, forcing all Q outputs LOW.

## MODE SELECT — TRUTH TABLE

OPERATING MODE	INPUTS			OUTPUTS	
	MR	A	B	$Q_0$	$Q_1-Q_7$
Reset (Clear)	L	X	X	L	L - L
Shift	H	l	l	L	$q_0 - q_6$
	H	l	h	L	$q_0 - q_6$
	H	h	l	L	$q_0 - q_6$
	H	h	h	H	$q_0 - q_6$

L (l) = LOW Voltage Levels

H (h) = HIGH Voltage Levels

X = Don't Care

$q_n$  = Lower case letters indicate the state of the referenced input or output one set-up time prior to the LOW to HIGH clock transition.

## GUARANTEED OPERATING RANGES

Symbol	Parameter		Min	Typ	Max	Unit
$V_{CC}$	Supply Voltage	54 74	4.5 4.75	5.0 5.0	5.5 5.25	V
$T_A$	Operating Ambient Temperature Range	54 74	-55 0	25 25	125 70	$^{\circ}\text{C}$
$I_{OH}$	Output Current — High	54, 74			-0.4	mA
$I_{OL}$	Output Current — Low	54 74			4.0 8.0	mA

# SN54/74LS164

## DC CHARACTERISTICS OVER OPERATING TEMPERATURE RANGE (unless otherwise specified)

Symbol	Parameter		Limits			Unit	Test Conditions	
			Min	Typ	Max			
V <sub>IH</sub>	Input HIGH Voltage		2.0			V	Guaranteed Input HIGH Voltage for All Inputs	
V <sub>IL</sub>	Input LOW Voltage	54			0.7	V	Guaranteed Input LOW Voltage for All Inputs	
		74			0.8			
V <sub>IK</sub>	Input Clamp Diode Voltage			-0.65	-1.5	V	V <sub>CC</sub> = MIN, I <sub>IN</sub> = -18 mA	
V <sub>OH</sub>	Output HIGH Voltage	54	2.5	3.5		V	V <sub>CC</sub> = MIN, I <sub>OH</sub> = MAX, V <sub>IN</sub> = V <sub>IH</sub> or V <sub>IL</sub> per Truth Table	
		74	2.7	3.5				
V <sub>OL</sub>	Output LOW Voltage	54, 74		0.25	0.4	V	I <sub>OL</sub> = 4.0 mA	V <sub>CC</sub> = V <sub>CC</sub> MIN, V <sub>IN</sub> = V <sub>IH</sub> or V <sub>IL</sub> per Truth Table
		74		0.35	0.5	V	I <sub>OL</sub> = 8.0 mA	
I <sub>IH</sub>	Input HIGH Current				20	μA	V <sub>CC</sub> = MAX, V <sub>IN</sub> = 2.7 V	
					0.1	mA	V <sub>CC</sub> = MAX, V <sub>IN</sub> = 7.0 V	
I <sub>IL</sub>	Input LOW Current				-0.4	mA	V <sub>CC</sub> = MAX, V <sub>IN</sub> = 0.4 V	
I <sub>OS</sub>	Short Circuit Current (Note 1)		-20		-100	mA	V <sub>CC</sub> = MAX	
I <sub>CC</sub>	Power Supply Current				27	mA	V <sub>CC</sub> = MAX	

Note 1: Not more than one output should be shorted at a time, nor for more than 1 second.

## AC CHARACTERISTICS (T<sub>A</sub> = 25°C)

Symbol	Parameter		Limits			Unit	Test Conditions	
			Min	Typ	Max			
f <sub>MAX</sub>	Maximum Clock Frequency		25	36		MHz	V <sub>CC</sub> = 5.0 V C <sub>L</sub> = 15 pF	
t <sub>PHL</sub>	Propagation Delay MR to Output Q			24	36	ns		
t <sub>PLH</sub> t <sub>PHL</sub>	Propagation Delay Clock to Output Q			17 21	27 32	ns		

## AC SETUP REQUIREMENTS (T<sub>A</sub> = 25°C)

Symbol	Parameter		Limits			Unit	Test Conditions	
			Min	Typ	Max			
t <sub>W</sub>	CP, MR Pulse Width		20			ns	V <sub>CC</sub> = 5.0 V	
t <sub>s</sub>	Data Setup Time		15			ns		
t <sub>h</sub>	Data Hold Time		5.0			ns		
t <sub>rec</sub>	MR to Clock Recovery Time		20			ns		

# SN54/74LS164

## AC WAVEFORMS

\*The shaded areas indicate when the input is permitted to change for predictable output performance.

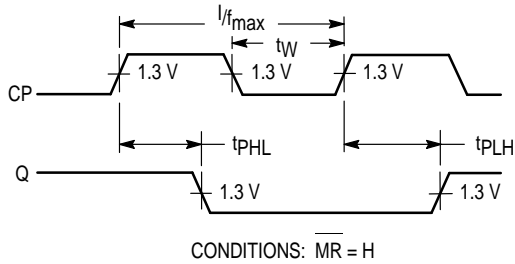

**Figure 1. Clock to Output Delays and Clock Pulse Width**

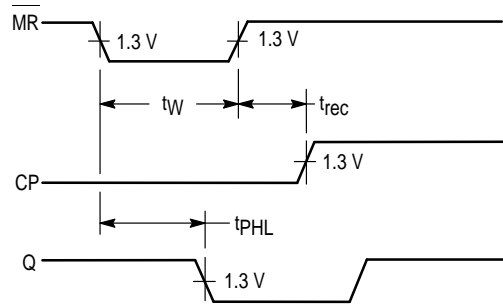

**Figure 2. Master Reset Pulse Width, Master Reset to Output Delay and Master Reset to Clock Recovery Time**

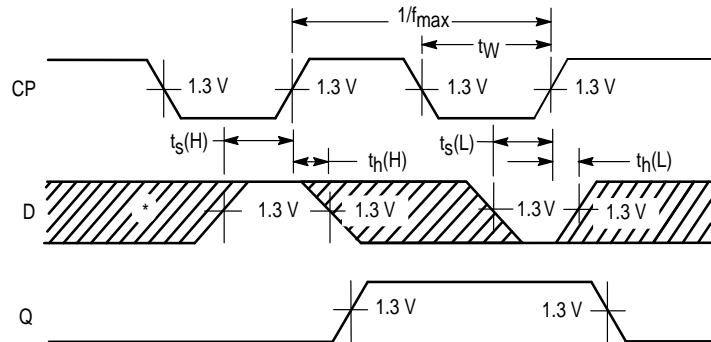

**Figure 3. Data Setup and Hold Times**