



# SPX116

## Low Dropout Voltage Three Terminal Regulator

### FEATURES

- 3.5V, 3.3V, 3.0V and Adjustable Versions Available
- Very Low Dropout Voltage
- Output Current In Excess Of 100mA
- Low Standby Current (ON, No Load)
- Short Circuit Protection
- Internal Thermal Shutdown
- Available in TO-92, SO-8 & SO-89 Packages
- Direct Replacement Pin to Pin to TK116

### APPLICATIONS

- Battery Powered Systems
- Cordless Telephones
- Radio Control Systems
- Portable/ Palm Top / Notebook Computers
- Portable Consumer Equipment
- Portable Instrumentation
- Pager
- Low Voltage Systems
- Cellular Phone

### PRODUCT DESCRIPTION

The SPX116 is a low power voltage regulators. This devices are an excellent choice for use in battery-powered applications such as cordless telephones, radio control systems, and pagers. The SPX116 features very low quiescent current in ON (400 $\mu$ A no load and 2mA at 60mA load) and OFF mode and very low dropout voltage of less than 200mV at 80mA load through internal PNP pass-transistor. The junction temperature of 150 $^{\circ}$ C is achieved through an internal thermal shutdown. In case of short circuit, the SPX116 will shut down.

This device is available in 3.0V, 3.3V and 3.5V output voltages. This regulator is available in TO-92, SO-8 and SOT-89 packages, it can also be supplied in tape and reel. The SPX116 is a direct replacement to TK116.

### PIN CONNECTIONS

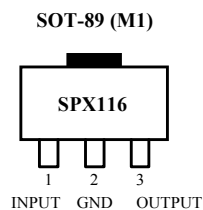

Front View

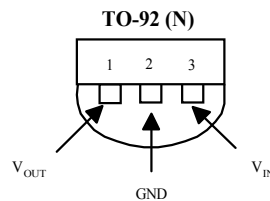

Bottom View

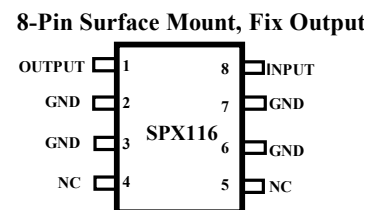

Top View

## ABSOLUTE MAXIMUM RATINGS

Power Dissipation.....500 mW  
 Lead Temp. (Soldering, 5 Seconds)..... 240°C  
 Storage Temperature Range ..... -65° to +150°C  
 Operating Junction Temperature Range  
 SPX116..... +150°C

Input Supply Voltage ..... -20 to +60V  
 Feedback Input Voltage ..... -1.5 to +30V  
 Shutdown Input Voltage..... -0.3 to +30V  
 Output Voltage.....  $V_{OUT} \times 1.15 V$   
 Load Current ..... 180 mA

## ELECTRICAL CHARACTERISTICS at Ta=25°C, unless otherwise specified.

Parameter	Symbol	Test Conditions	Min	Typ	Max	Units
Supply Voltage Range	$V_{IN}$		2.5		14	V
Supply Current	$I_{IN1}$	$I_{OUT}=0mA, V_{CONT}=0, ON Mode$		400		$\mu A$
Supply Current	$I_{IN2}$	$V_{CONT}=V_{IN}, OFF Mode$		800		$\mu A$
Regulated Output Voltage	$V_{OUT}$	$V_{IN}=V_{OUT} + 1 V, I_{OUT}=10mA$	-3.0	$V_{OUT}$	+3.0	%
Dropout voltage	$V_{DROPI}$	$I_{OUT}=10mA$		50		mV
Dropout Voltage	$V_{DROPII}$	$I_{OUT}=60mA$		170		mV
Output Current	$I_{OUT}$		100			mA
Line Regulation	$LI_{REG}$	$V_{OUT}+1.0V$ to $\leq V_{IN} \leq V_{OUT}+6.0V$		0.01		%/V
Load Regulation	$LD_{REG}$	$10 mA \leq I_{OUT} \leq 60mA, V_{IN}=V_{OUT}+1.5$		0.02		%/mA
Ripple Rejection	$V_{RIPPLE}$	$100mV_{RMS}, f=400Hz$ $V_{IN}=V_{OUT}+1.5V, I_{OUT}=10mA$		55		dB
Output Voltage Temperature Coefficient	$\Delta V_{OUT} / \Delta T_A$	$0^{\circ}C \leq T_A \leq 75^{\circ}C$ $V_{IN}=V_{OUT}+1.5V, I_{OUT}=10mA$		$\pm 0.2$		mV/°C
Output Noise Voltage	$V_N$	$V_{IN}=V_{OUT} + 1.5V, I_{OUT}=10mA$ $10Hz < f < 100kHz, I_{OUT}=10mA$		150		$\mu V_{RMS}$

## TEST CIRCUIT

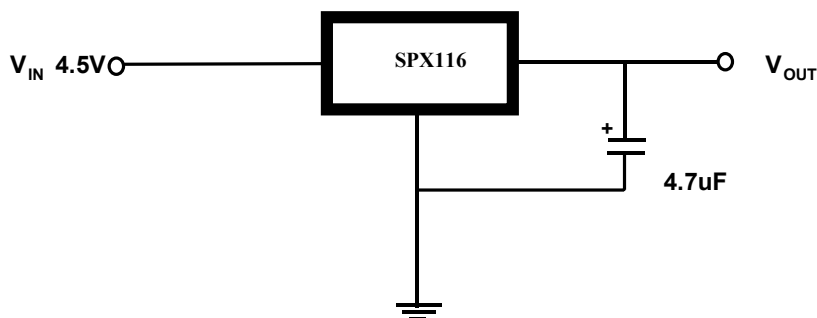

TYPICAL CHARACTERISTICS

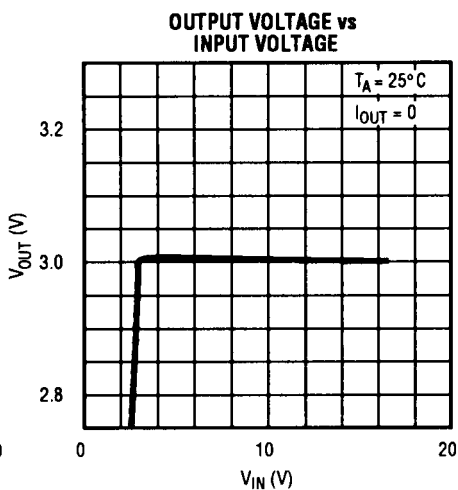
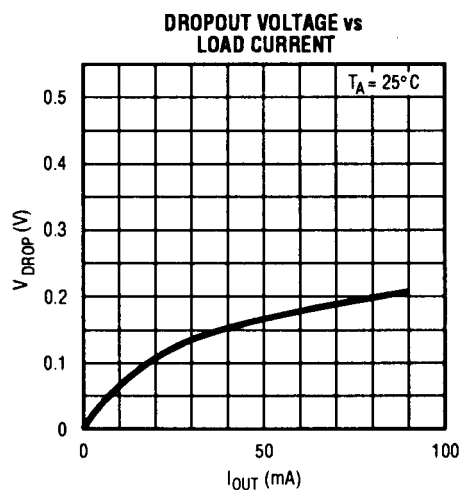
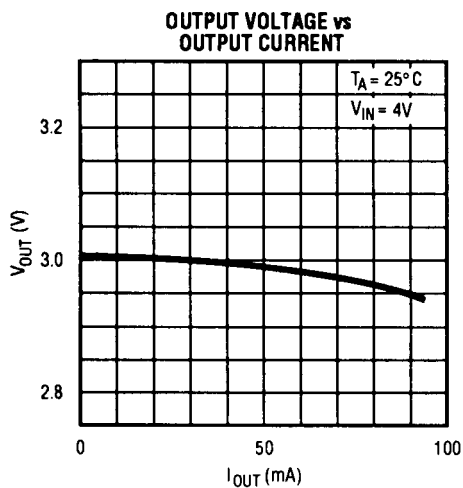
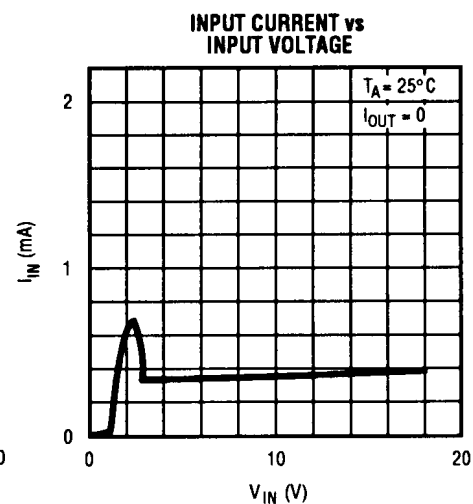
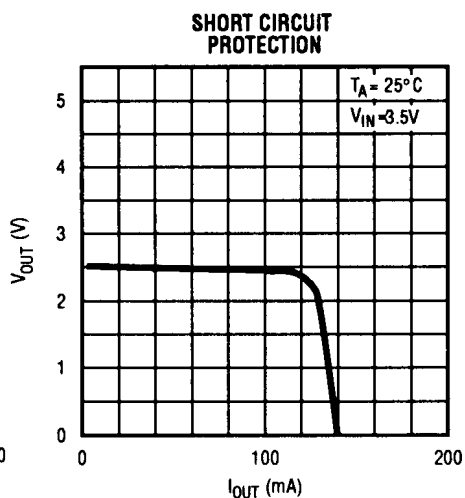
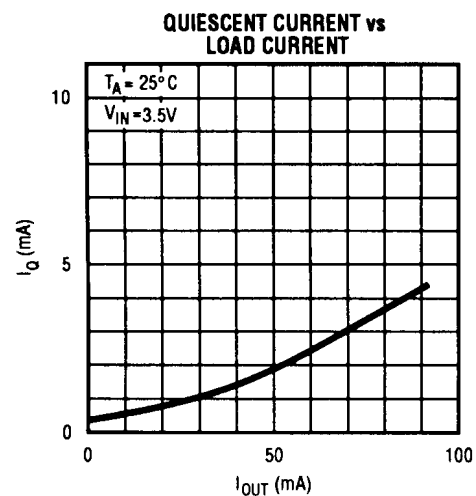
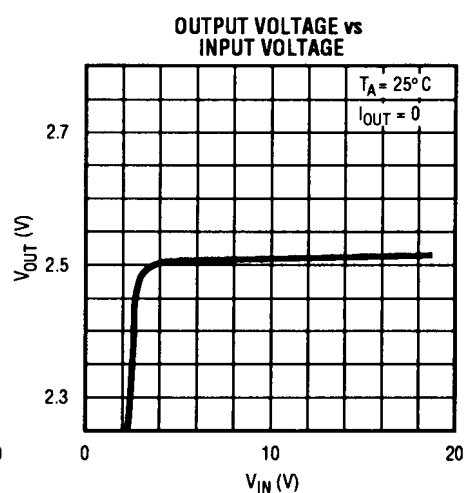
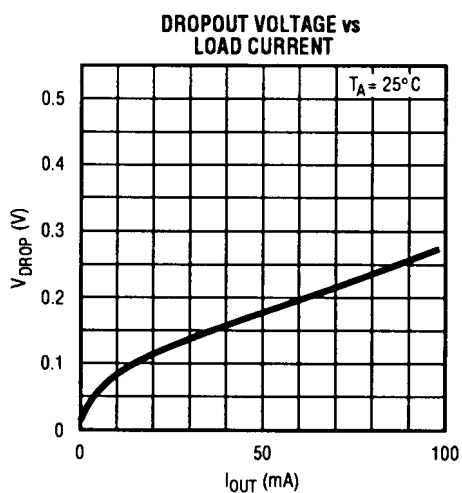
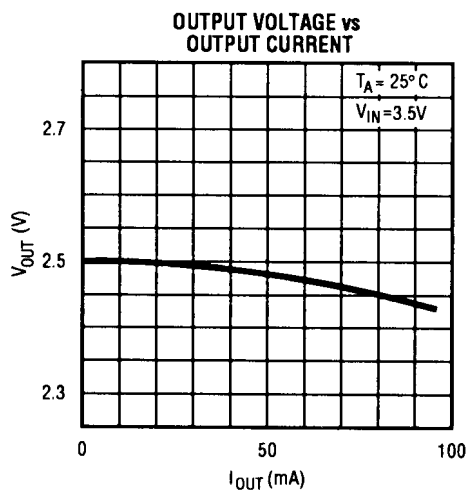

## TYPICAL CHARACTERISTICS

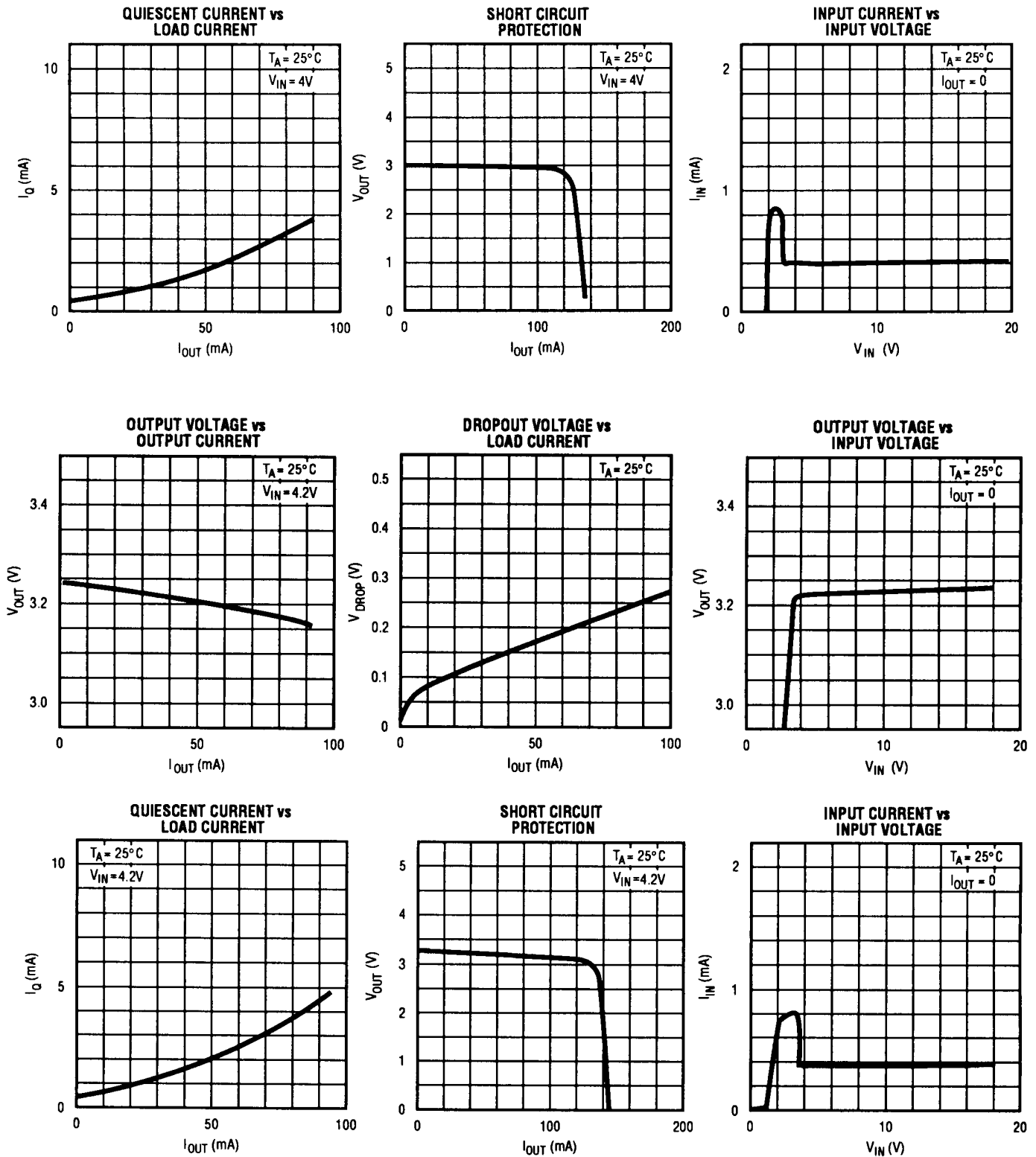

## TYPICAL CHARACTERISTICS

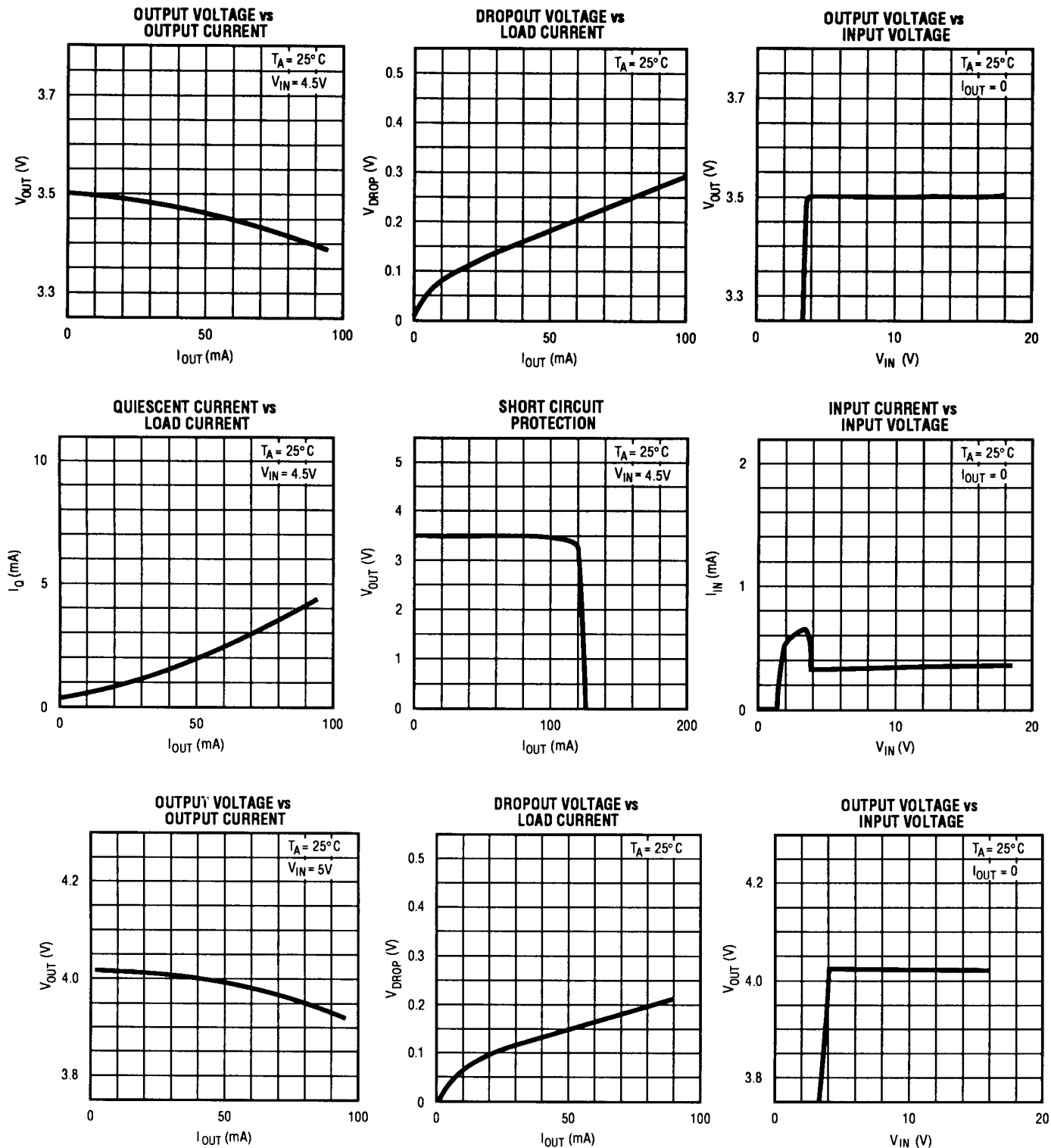

TYPICAL CHARACTERISTICS

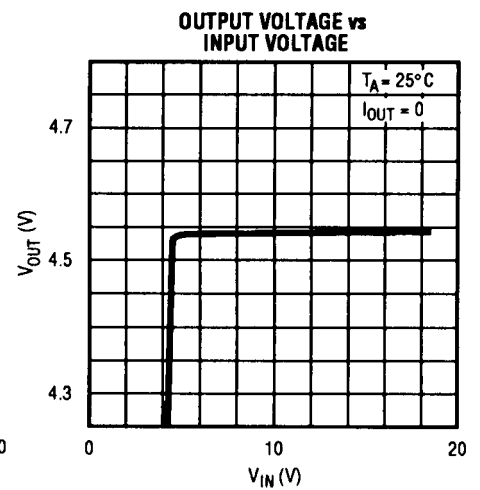
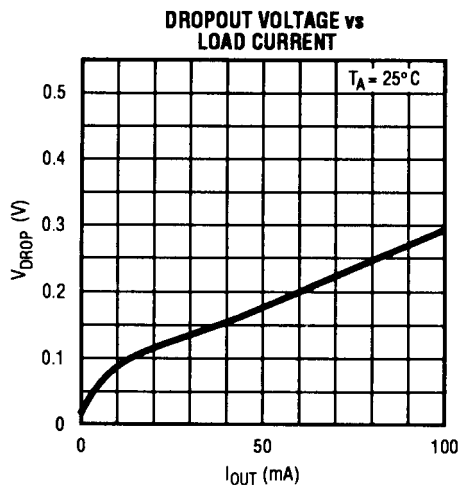
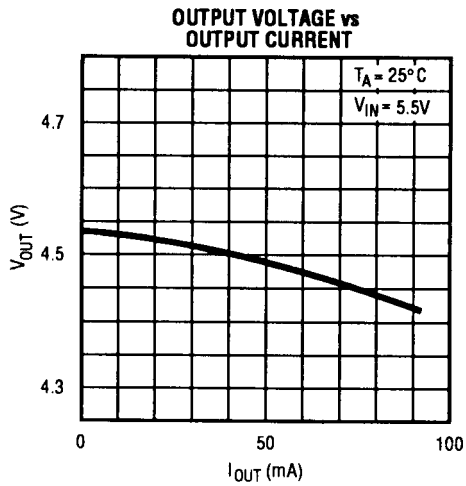
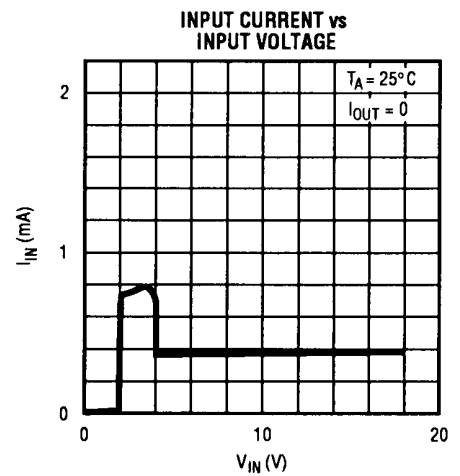
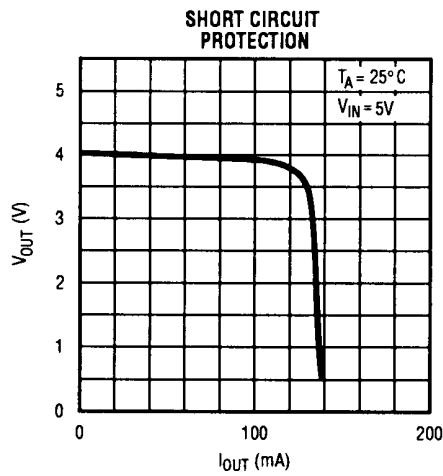
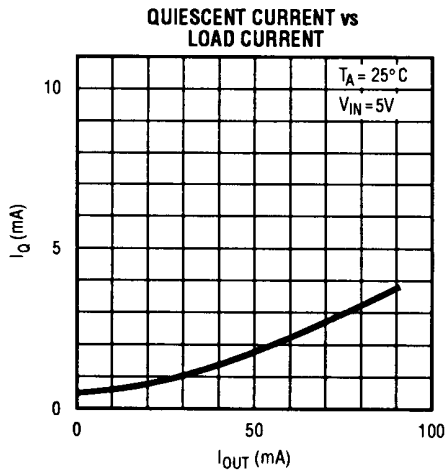

TYPICAL CHARACTERISTICS

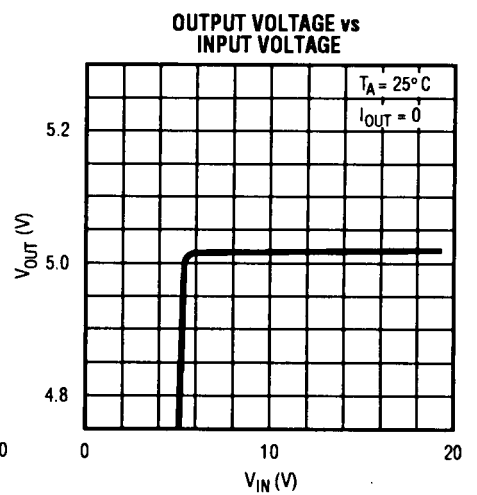
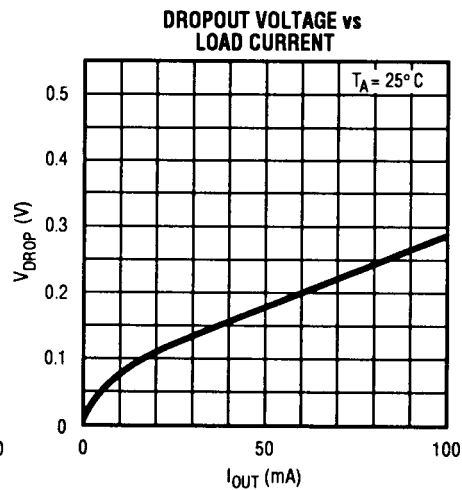
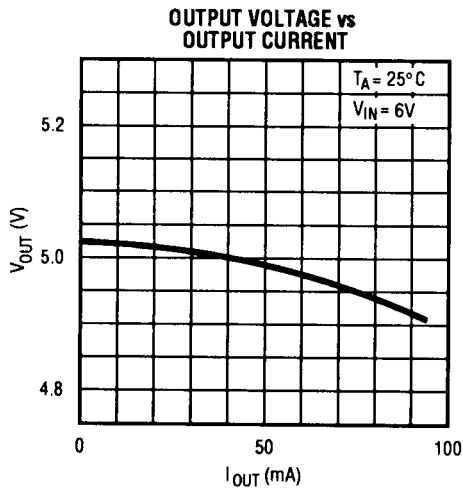
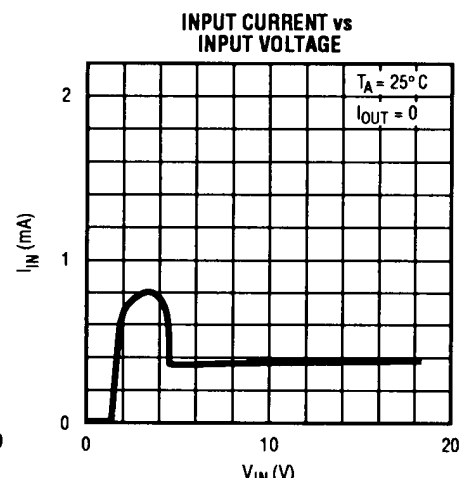
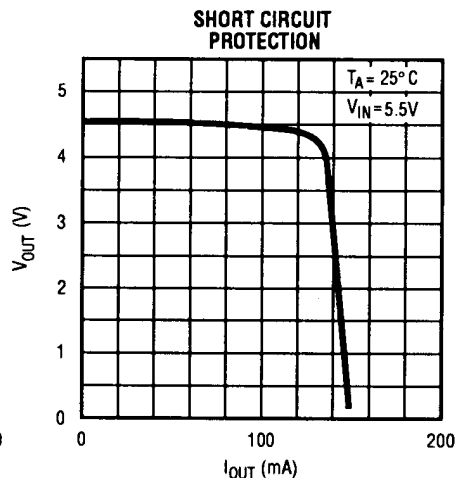
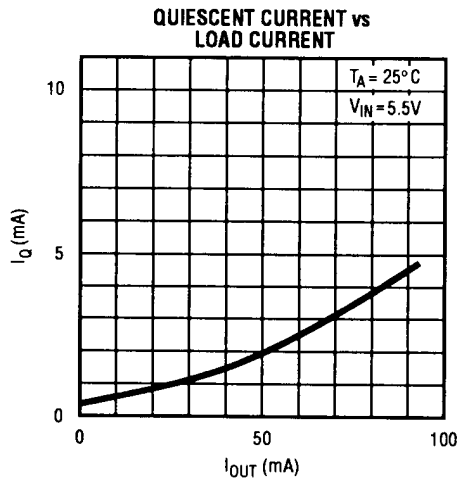

TYPICAL CHARACTERISTICS

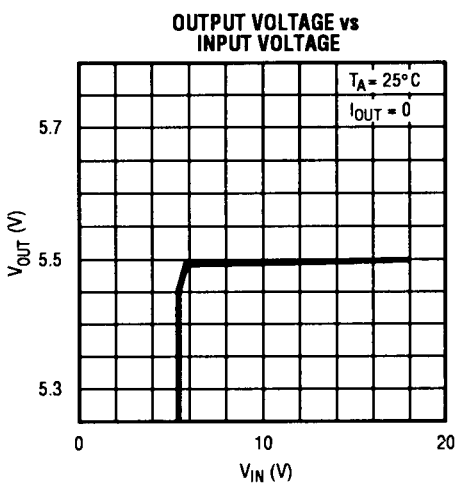
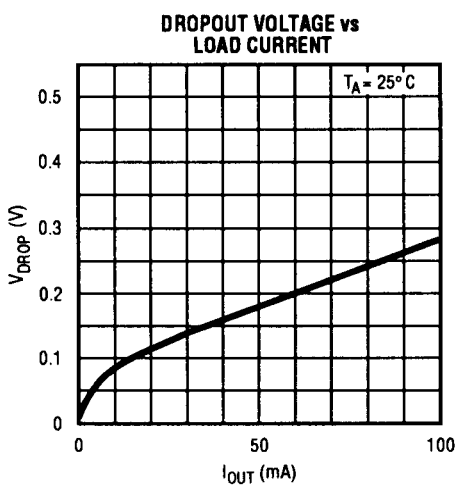
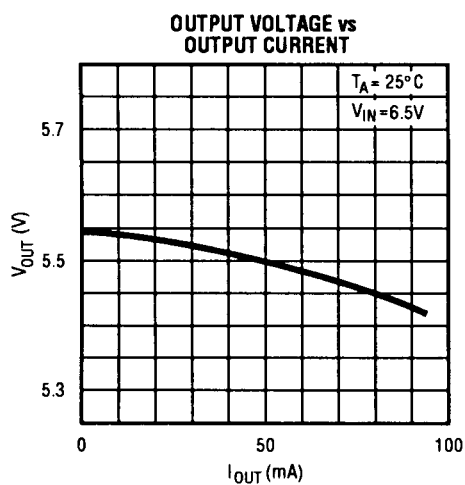
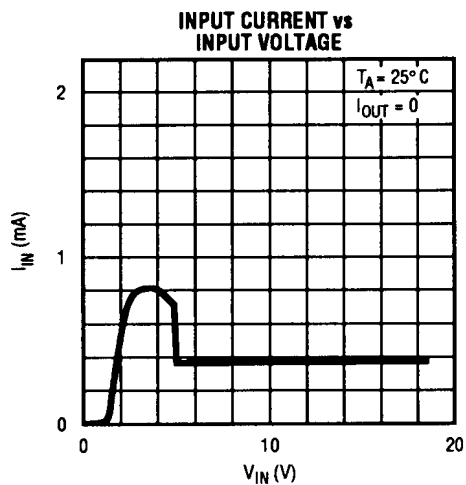
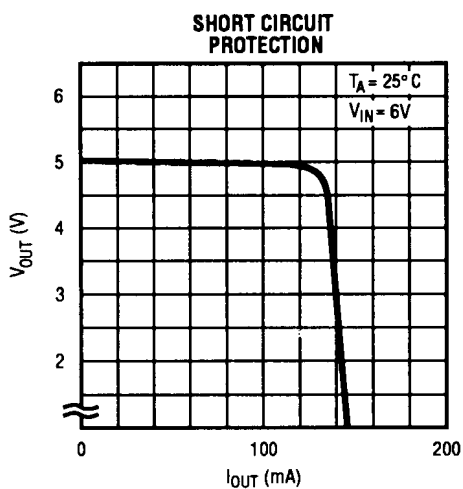
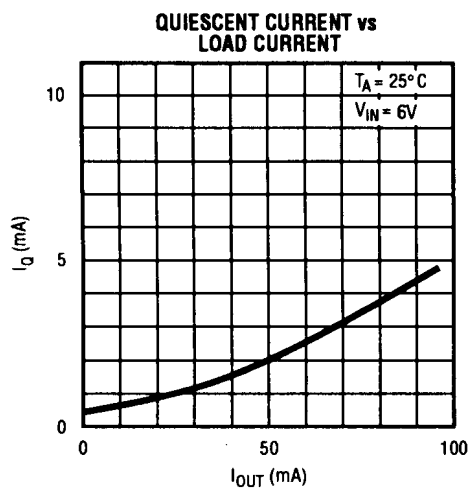



TYPICAL CHARACTERISTICS

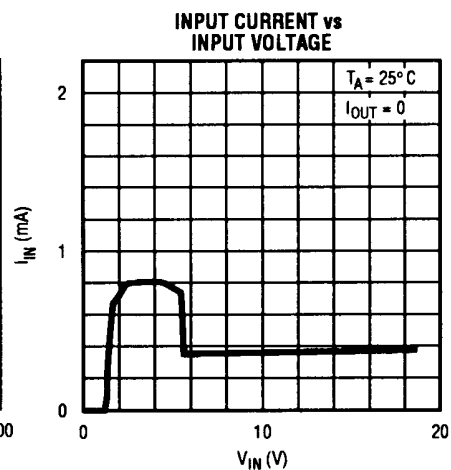
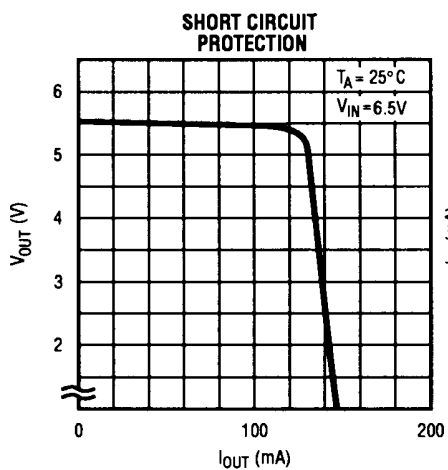
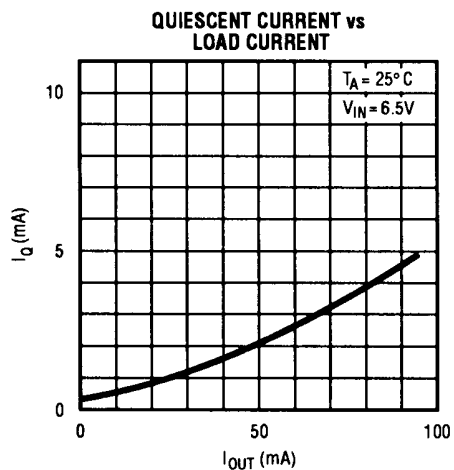

## SPX116 Adjustable Output

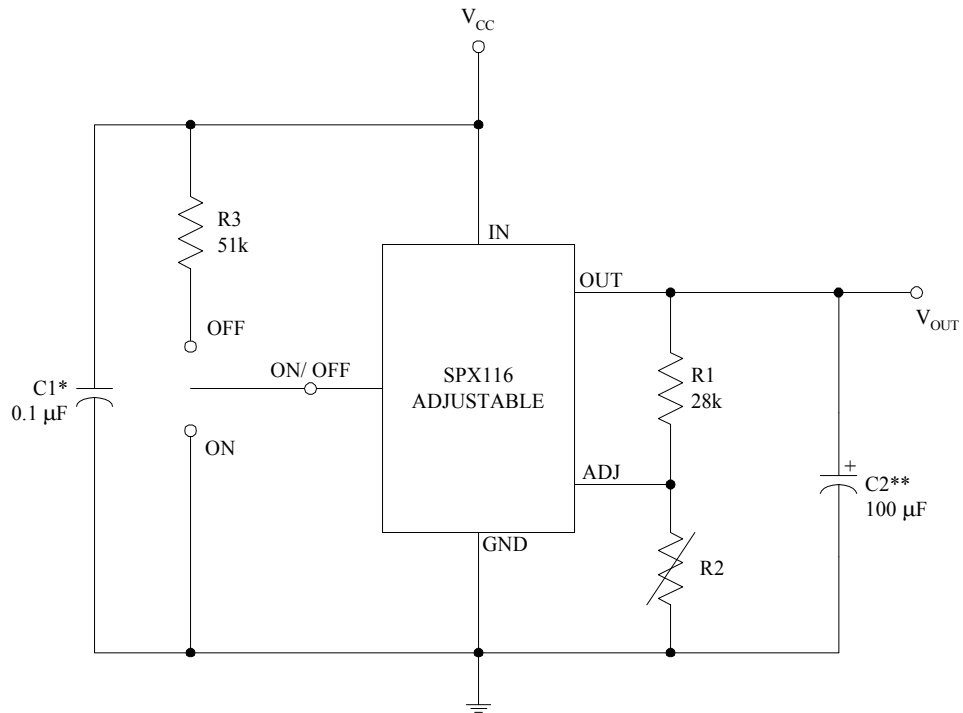

$$V_{OUT} = \text{Reference Voltage} \times \frac{R1 + R2}{R1}$$

**Note:** Using 27K for R1 will automatically compensate for errors in  $V_{OUT}$  due to the input bias current of the ADJ pin (approximately  $1\mu\text{A}$ ).

## ORDERING INFORMATION

Ordering No.	Precision	Output Voltage	Packages
SPX116N	3%	Adj	3 Lead TO-92
SPX116N-3.0	3%	3.0V	3 Lead TO-92
SPX116N-3.3	3%	3.3V	3 Lead TO-92
SPX116N-3.5	3%	3.5V	3 Lead TO-92
SPX116S	3%	Adj	8 Lead SOIC
SPX116S-3.0	3%	3.0V	8 Lead SOIC
SPX116S-3.3	3%	3.3V	8 Lead SOIC
SPX116S-3.5	3%	3.3V	8 Lead SOIC
SPX116M1	3%	Adj	3 Lead SOT-89
SPX116M1-3.0	3%	3.0V	3 Lead SOT-89
SPX116M1-3.3	3%	3.3V	3 Lead SOT-89
SPX116M1-5.0	3%	5.0V	3 Lead SOT-89



SIGNAL PROCESSING EXCELLENCE

### Sipex Corporation

**Headquarters and Main Offices:**  
22 Linnell Circle  
Billerica, MA 01821  
TEL: (978) 667-8700  
FAX: (978) 670-9001  
e-mail: sales@sipex.com

233 South Hillview Drive  
Milpitas, CA 95035  
TEL: (408) 935-7600  
FAX: (408) 934-7500

Sipex Corporation reserves the right to make changes to any products described herein. Sipex does not assume any liability arising out of the application or use of any product or circuit described hereing; neither does it convey any license under its patent rights nor the rights of others.