

250mA Low Dropout Voltage Regulator

FEATURES

- 5.0V and 3.3V Versions at 250mA Output
- Accurate 0.5% for SPX2954A
- Very Low Quiescent Current
- Low Dropout: 310mV at 250mA
- Extremely Tight Load and Line Regulation
- Very Low Temperature Coefficient
- Current and Thermal Limiting
- Need only 1 μ F for Stability
- Direct Replacement for LP2954
- Offered in TO-92, TO-263, SOT-223, & TO-220; also SOIC--**8 Pin Versions Only**
- Error Flag Warns of Output Dropout
- Logic-Controlled Electronic Shutdown
- Programmable Output from 1.24V to 30V

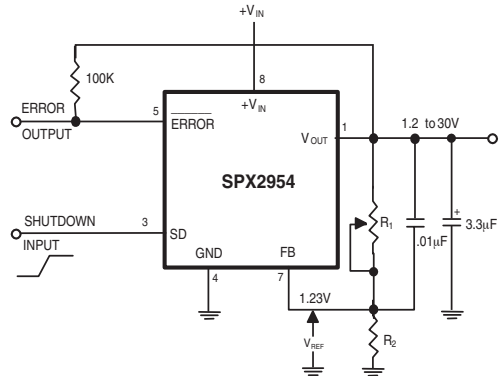

DESCRIPTION

The SPX2954 and SPX2954A are low power voltage regulators. These devices are an excellent choice for use in battery-powered applications such as cordless telephones, radio control systems, and portable computers. The SPX2954 and SPX2954A feature low quiescent current and low dropout voltage (typ. 20mV at 100 μ A and 310mV at 250mA). This includes a tight initial tolerance (0.5% for SPX2954A), extremely good load and line regulation (0.05% typ.), and very low output temperature coefficient (20 ppm/ $^{\circ}$ C typ.), making the SPX2954/SPX2954A useful as a low-power voltage reference.

The error flag output feature is used as a power-on reset for warning of a low output voltage, due to a falling input voltage. The logic-compatible shutdown feature enables the regulator to be switched ON and OFF. The SPX2954/SPX2954A is offered in 3-pin TO-92, TO-263, SOT-223 and TO-220 packages, and 8 pin SOIC package.

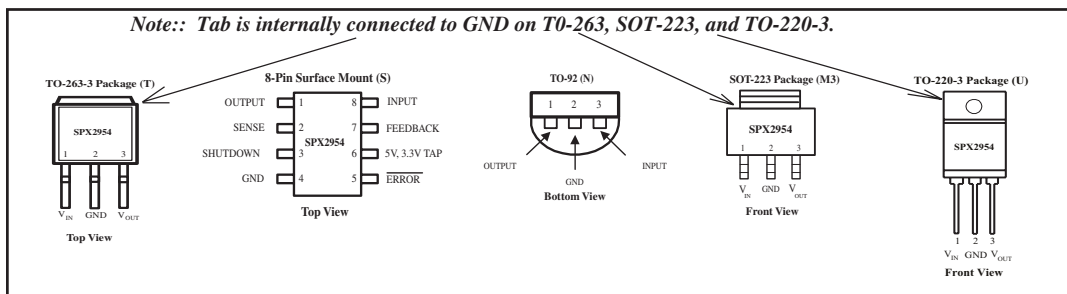

Pin Connections

ABSOLUTE MAXIMUM RATINGS

Power Dissipation.....Internally Limited
 Lead Temperature (soldering, 5 seconds)260°C
 Storage Temperature Range.....-65°C to +150°C
 Operating Junction Temperature Range.....-40°C to +125°C
 Input Supply Voltage.....-0.3V to +30V

Feedback Input Voltage.....-1.5V to +30V
 Shutdown Input Voltage-0.3V to +30V
 Error Comparator Output.....-0.3V to +30V
 ESD Rating.....2kV Min

ELECTRICAL CHARACTERISTICS $V_{IN}=V_O + 1V$, $I_L=100\mu A$, $C_L=1\mu F$ (NOTE 2), $T_A = 25^\circ C$, unless otherwise specified.

PARAMETER	CONDITIONS	SPX2954A			SPX2954			UNIT
		MIN.	TYP.	MAX	MIN.	TYP.	MAX.	
3.3 V Versions								
Output Voltage	$T_J=25^\circ C$	3.284	3.3	3.317	3.267	3.3	3.333	V
	$-25^\circ C \leq T_J \leq 85^\circ C$	3.267	3.3	3.333	3.251	3.3	3.350	
	Full Operating Temp.	3.260	3.3	3.340	3.234	3.3	3.366	
Output Voltage	$100\mu A \leq I_L \leq 250\text{ mA}$ $T_J \leq T_{JMAX}$	3.251	3.3	3.350	3.201	3.3	3.399	V
5 V Versions								
Output Voltage	$T_J = 25^\circ C$	4.975	5.0	5.025	4.950	5.0	5.050	V
	$-25^\circ C \leq T_J \leq 85^\circ C$	4.950	5.0	5.050	4.925	5.0	5.075	
	Full Operating Temp.	4.940	5.0	5.060	4.900	5.0	5.100	
Output Voltage	$100\mu A \leq I_L \leq 250\text{ mA}$ $T_J \leq T_{JMAX}$	4.925	5.0	5.075	4.850	5.0	5.150	V
All Voltage Options								
Output Voltage Temperature Coefficient	(NOTE 1)		20	100		50	150	ppm/°C
Line Regulation (NOTE 3)	$V_O+1V \leq V_{IN} \leq 30V$ (NOTE 4)		0.03	0.10		0.04	0.20	%
Load Regulation (NOTE 3)	$100\mu A \leq I_L \leq 250\text{ mA}$		0.04	0.20		0.10	0.30	%
Dropout Voltage (NOTE 5)	$I_L = 1\text{ mA}$		60	100		60	100	mV
	$I_L = 100\text{ mA}$		290	450		290	450	
	$I_L = 250\text{ mA}$		310	500		310	500	
Ground Current	$I_L = 1\text{ mA}$		150	170		150	170	μA mA mA
	$I_L = 100\text{ mA}$		3	6		3	6	
	$I_L = 250\text{ mA}$		10	14		10	14	
Current Limit	$V_{OUT} = 0$		270	550		270	550	mA
Thermal Regulation			0.05	0.2		0.05	0.2	%/W
Output Noise, 10Hz to 100kHz	$C_L = 1\mu F$		430			430		μV rms
	$C_L = 200\mu F$		160			160		μV rms
	$C_L = 3.3\mu F$, Bypass= 0.01 μF from Pin 7 to Pin 1 (8 pin Versions)		100			100		μV rms
8-Pin Versions only								
Reference Voltage		1.220	1.235	1.250	1.210	1.235	1.260	V
Reference Voltage	Over Temp (NOTE 6)	1.190		1.270	1.185		1.285	V
Feedback Pin Bias Current			40	60		40	60	nA
Vref Temperature Coefficient			20			50		ppm/°C
Feedback I_{BIAS} Temperature Coefficient			0.1			0.1		nA/°C

ELECTRICAL CHARACTERISTICS (Cont.) $V_{IN}=V_O+1V$, $I_L=100\mu A$, $C_L=1\mu F$ (NOTE 2), $T_A = 25^\circ C$, unless otherwise specified.

PARAMETER	CONDITIONS	SPX2954A			SPX2954			UNIT
		MIN.	TYP.	MAX	MIN.	TYP.	MAX.	
Error Comparator								
Output Leakage Current	$V_{OH} = 30V$		0.01	1		0.01	1	μA
Output Low Voltage	$V_{IN} = V_O - 0.5V$, $I_{OL} = 400\mu A$		150	250		150	250	mV
Upper Threshold Voltage	(NOTE 7)	40	60		40	60		mV
Lower Threshold Voltage	(NOTE 7)		75	95		75	95	mV
Hysteresis	(NOTE 7)		15			15		mV
Shutdown								
Input logic Voltage	Low (Regulator ON) High (Regulator OFF)	2.0	1.3	0.7	2.0	1.3	0.7	V
Shutdown Input Current	$V_S = 2.4V$ $V_S = 30V$		30 400	50 800		30 400	50 800	μA
Regulator Output Current in Shutdown	(NOTE 8)		3	10		3	10	μA
Thermal Resistance θ_{JA}								
TO-263-3			31.4					$^\circ C/W$
SOIC-8			128.4					$^\circ C/W$
TO-92-3			131.9					$^\circ C/W$
SOT-223			62.3					$^\circ C/W$
TO-220-3			29.4					$^\circ C/W$

NOTE 1: Output or reference voltage temperature coefficients defined as the worst case voltage change divided by the total temperature range.

NOTE 2: Unless otherwise specified all limits guaranteed for $T_J = 25^\circ C$, $V_{IN} = 6V$, $I_L = 100\mu A$ and $C_L = 1\mu F$. Additional conditions for the 8-pin versions are feedback tied to 5V tap and output tied to output sense ($V_{OUT} = 5V$) and $V_{SHUTDOWN} \leq 0.8V$.

NOTE 3: Regulation is measured at constant junction temperature, using pulse testing with a low duty cycle. Changes in output voltage due to heating effects are covered under the specification for thermal regulation.

NOTE 4: Line regulation for the SPX2954 is tested at $I_L = 1mA$.

NOTE 5: Dropout voltage is defined as the input to output differential at which the output voltage drops 100mV below its nominal value measured at 1V differential. At very low values of programmed output voltage, the minimum input supply voltage of 2V (2.3V over temperature) must be taken into account.

NOTE 6: $V_{REF} \leq V_{OUT} \leq (V_{IN} - 1V)$, $2.3 \leq V_{IN} \leq 30V$, $100\mu A \leq I_L \leq 250mA$, $T_J \leq T_{JMAX}$.

NOTE 7: Comparator thresholds are expressed in terms of a voltage differential at the feedback terminal below the nominal reference voltage measured at 6V input. To express these thresholds in terms of output voltage change, multiply by the error amplifier gain = $V_{OUT}/V_{REF} = (R_1 + R_2)/R_2$. For example, at a programmed output voltage of 5V, the error output is guaranteed to go low when the output drops by 95 mV x 5V/1.235 = 384 mV. Thresholds remain constant as a percent of V_{OUT} as V_{OUT} is varied, with the dropout warning occurring at typically 5% below nominal, 7.5% guaranteed.

NOTE 8: $V_{SHUTDOWN} \geq 2V$, $V_{IN} \leq 30V$, $V_{OUT} = 0$, Feedback pin tied to 5V/3.3V Tap.

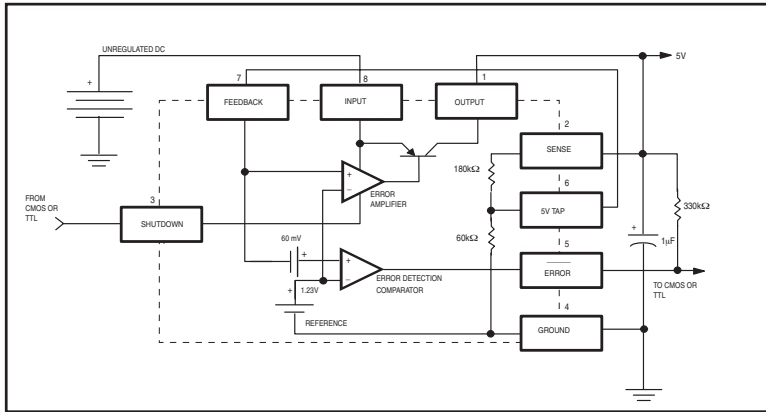

SPX2954 Block Diagram, 8 Lead 5V Version

TYPICAL PERFORMANCE CHARACTERISTICS

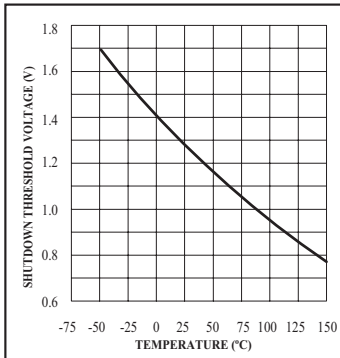

Shutdown Threshold Voltage

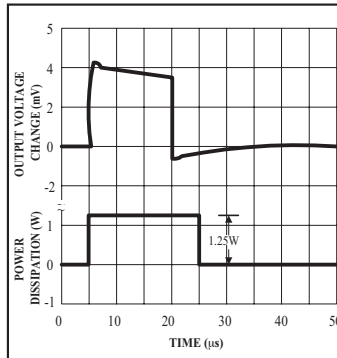

Thermal Response

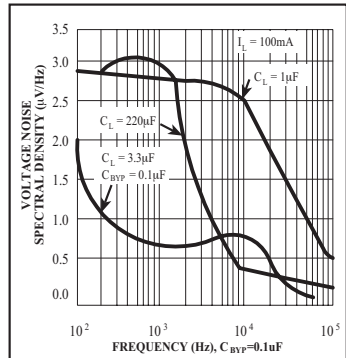

Output Noise

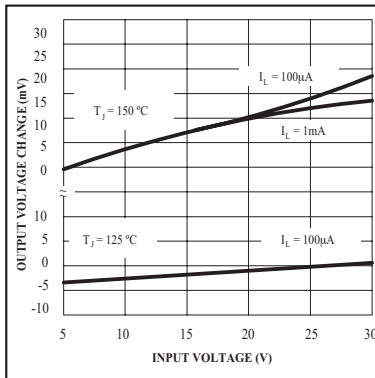

Line Regulation

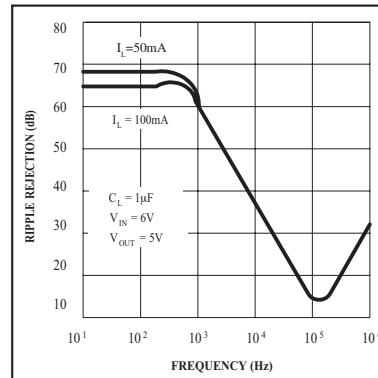

Ripple Rejection

TYPICAL PERFORMANCE CHARACTERISTICS

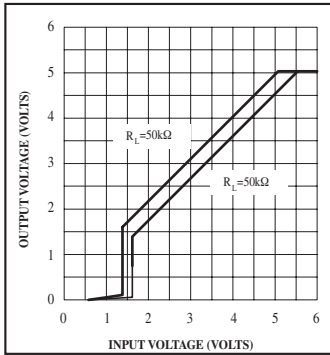

Dropout Characteristics

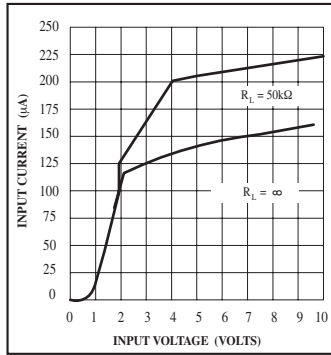

Input Current

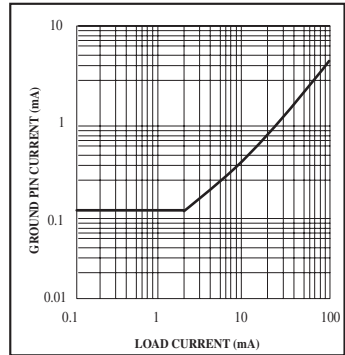

Quiescent Current

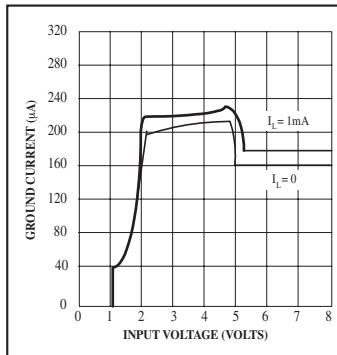

Ground Current

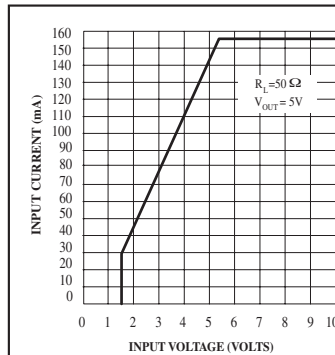

Input Current

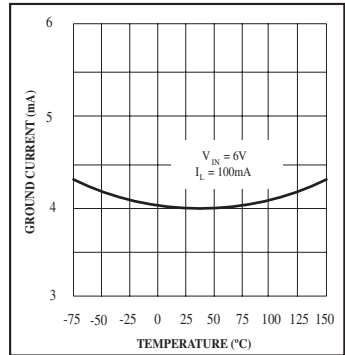

Ground Current

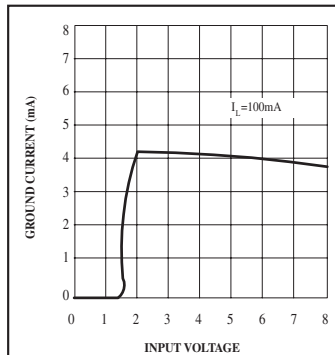

Ground Current

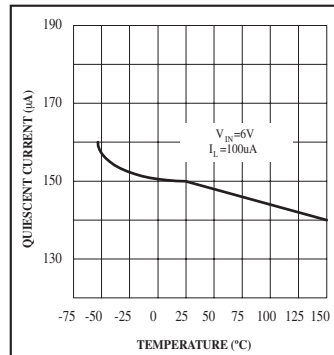

Quiescent Current

TYPICAL PERFORMANCE CHARACTERISTICS (CONT.)

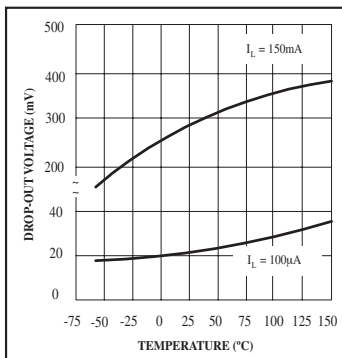

Drop-Out Voltage

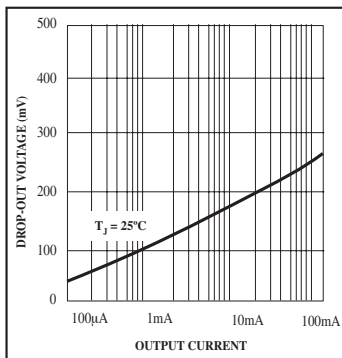

Drop-Out Voltage

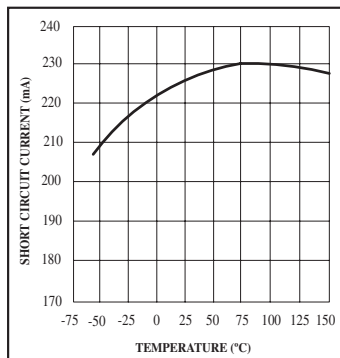

Short Circuit Current

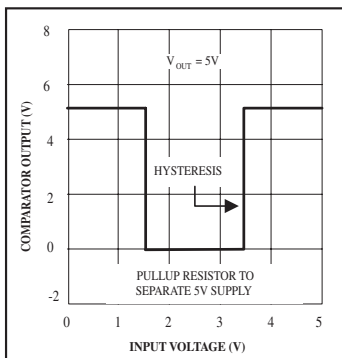

Error Comparator Output

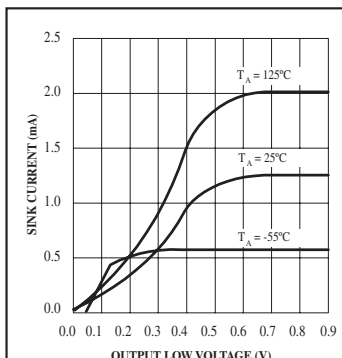

Comparator Sink Current

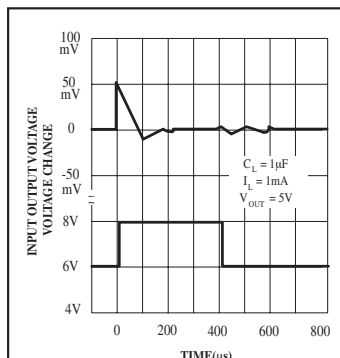

Line Transient Response

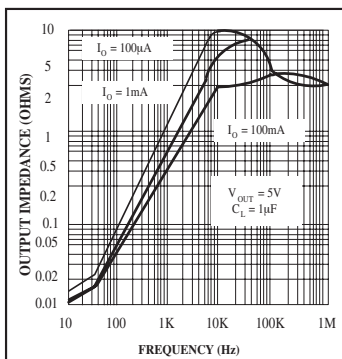

Output Impedance

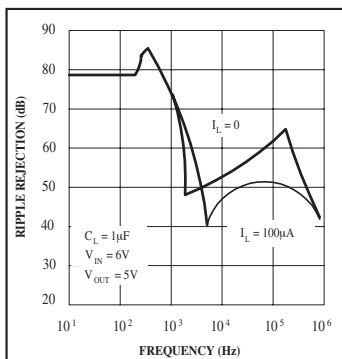

Ripple Rejection

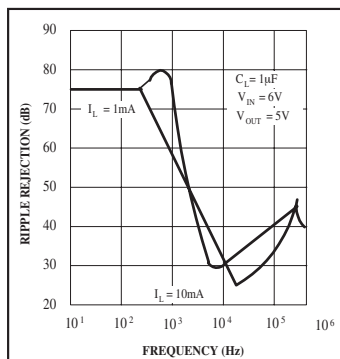

Ripple Rejection

TYPICAL PERFORMANCE CHARACTERISTICS (CONT.)

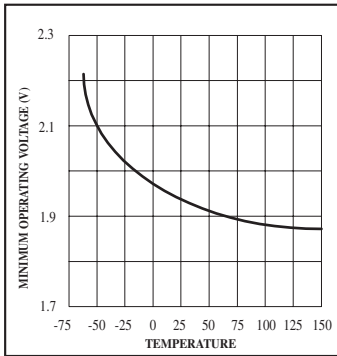

Minimum Operating Voltage

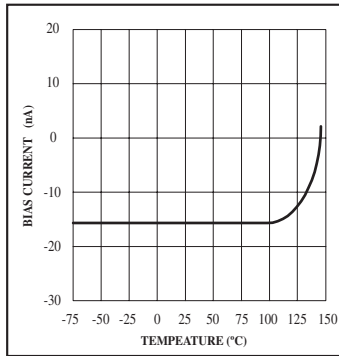

Feedback Bias Current

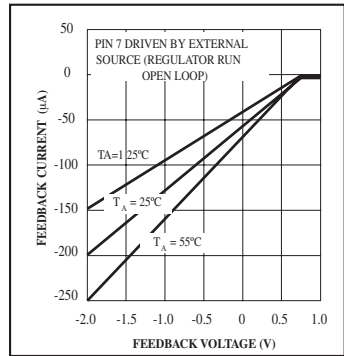

Feedback Pin Current

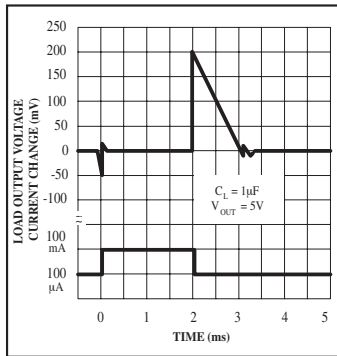

Load Transient Response

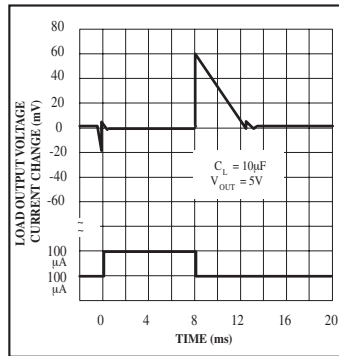

Load Transient Response

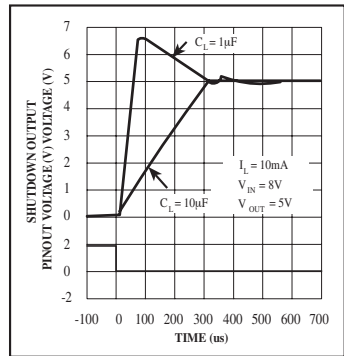

Enable Transient

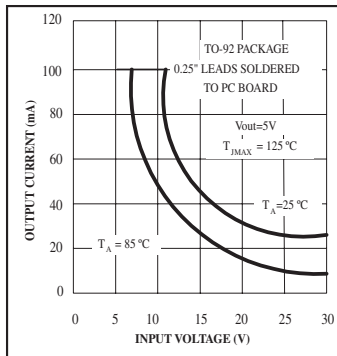

Maximum Rated Output

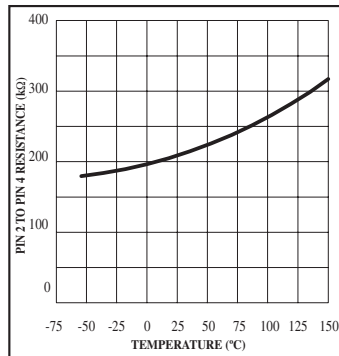

Divider Resistance

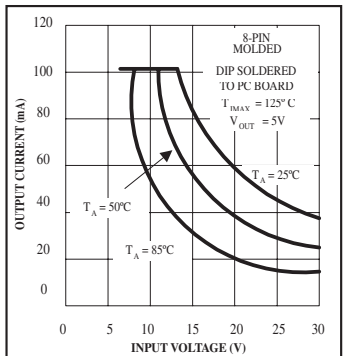

Maximum Rated Output Current

APPLICATIONS HINTS

EXTERNAL CAPACITORS

The stability of the SPX2954 requires a 1 μ F or greater capacitor between output and ground. Oscillation could occur without this capacitor. Most types of tantalum or aluminum electrolytic works fine here. For operations below -25°C solid tantalum is recommended since the many aluminum types have electrolytes that freeze at about -30°C. The ESR of about 5 Ω or less and resonant frequency above 500kHz are the most important parameters in the value of the capacitor. The capacitors value may be increased without limit.

At lower values of output current, less output capacitance is required for stability. For the currents below 10mA the value of the capacitor can be reduced to 0.33 μ F and 0.1 μ F for 1mA. More output capacitance is needed for the 8-pin version at voltages below 5V since it runs the error amplifier at lower gain. At worst case 3.3 μ F or greater must be used for the condition of 150mA load at 1.23V output.

The SPX2954 unlike other low dropout regulators will remain stable and in regulation with no load in addition to the internal voltage divider. This feature is especially important in applications like CMOS RAM keep-alive. When setting the output voltage of the SPX2954 version with external resistors, a minimum load of 1 μ A is recommended

If there is more than 10 inches of wire between the input and the AC filter capacitor or if a battery is used as the input then a 1 μ F tantalum or aluminum electrolytic capacitor should be placed from the input to the ground.

Instability can occur if there is stray capacitance to the SPX2954 feedback terminal (pin 7). This could cause more problems when using a higher value of external resistors to set the output voltage. This problem can be fixed by adding a 100pF capacitor between output and feedback and increasing the output capacitor to at least 3.3 μ F.

ERROR DETECTION COMPARATOR OUTPUT

The comparator produces a logic low output whenever the SPX2954 output falls out of regulation by more than around 5%. This is around 60 mV offset divided by the 1.235 reference voltage. This trip level remains 5% below normal regardless of the programmed output voltage of the regulator.

Figure 1 shows the timing diagram depicting the ERROR signal and the regulator output voltage as the SPX2954 input is ramped up and down. The ERROR signal becomes low at around 1.3V input, and goes high around 5V input (input voltage at which $V_{OUT} = 4.75$). Since the SPX2954's dropout voltage is load dependent, the input voltage trip point (around 5V) will vary with the load current. The output voltage trip point (approx. 4.75V) does not vary with load.

The error comparator has an open-collector output, which requires an external pull-up resistor. Depending on the system requirements the resistor may be returned to 5V output or other supply voltage. In determining the value of this resistor, note that the output is rated to sink 400mA, this value adds to battery drain in a low battery condition. Suggested values range from 100k to 1M Ω . If the output is unused this resistor is not required.

PROGRAMMING THE OUTPUT VOLTAGE OF SPX2954

The SPX2954 may be pin-strapped for 5V using its internal voltage divider by tying Pin 1 (output) to Pin 2 (sense) and Pin 7 (feedback) to Pin 6 (5V Tap). Also, it may be programmed for any output voltage between its 1.235V reference and its 30V maximum rating using an external pair of resistors. Refer to the below equation for the programming of the output voltage:

$$V_{OUT} = V_{REF} \times (1 + R_1/R_2) + I_{FB} R_1$$

The V_{REF} is 1.235 and I_{FB} is the feedback bias current, nominally -20nA. The minimum recommended load current of 1 μ A forces an

APPLICATIONS HINTS (CONT)

upper limit of $1.2M\Omega$ on value of R_2 . If no load is presented the I_{FB} produces an error of typically 2% in V_{OUT} which may be eliminated at room temperature by trimming R_1 . To improve the accuracy choose the value of $R_2 = 100k$ this reduces the error by 0.17% and increases the resistor program current by $12\mu A$. Since the SPX2954 typically draws $60\mu A$ at no load with Pin 2 open-circuited, this is a small price to pay.

REDUCING OUTPUT NOISE

It may be an advantage to reduce the AC noise present at the output. One way is to reduce the regulator bandwidth by increasing the size of the output capacitor. This is the only way that noise can be reduced on the 3 lead SPX2954 but is relatively inefficient, as increasing the capacitor from $1\mu F$ to $220\mu F$ only decreases the noise from $430\mu V$ to $160\mu VRMS$ for a $100kHz$ bandwidth at 5V output. Noise can be reduced four-fold by using a bypass capacitor across R_1 , since it reduces the high frequency gain from 4 to unity. Pick

$$C_{BYPASS} \cong (1 / 2\pi R_1 \times 200 \text{ Hz})$$

or choose $0.01\mu F$. When doing this, the output capacitor must be increased to $3.3\mu F$ to maintain stability. These changes reduce the output noise from $430\mu V$ to $100\mu VRMS$ for a $100kHz$ bandwidth at 5V output. With the bypass capacitor added, noise no longer scales with output voltage so that improvements are more dramatic at higher output voltages.

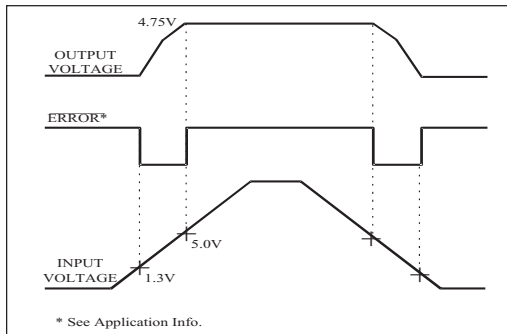

Figure 1. Error Output Timing

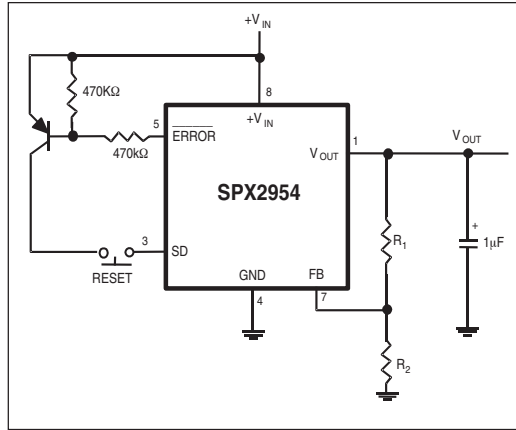

Figure 2. Latch Off when Error Flag Occurs

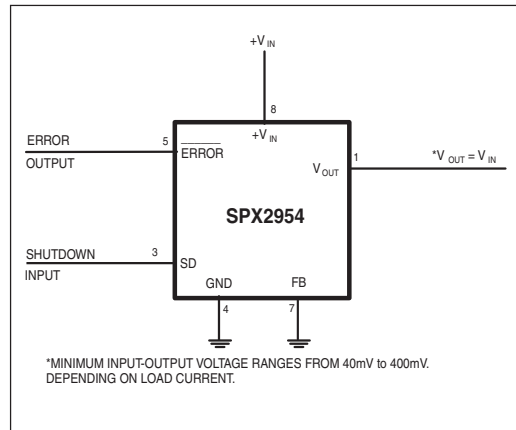

Figure 3. Wide Input Voltage Range, Current Limiter

APPLICATIONS HINTS

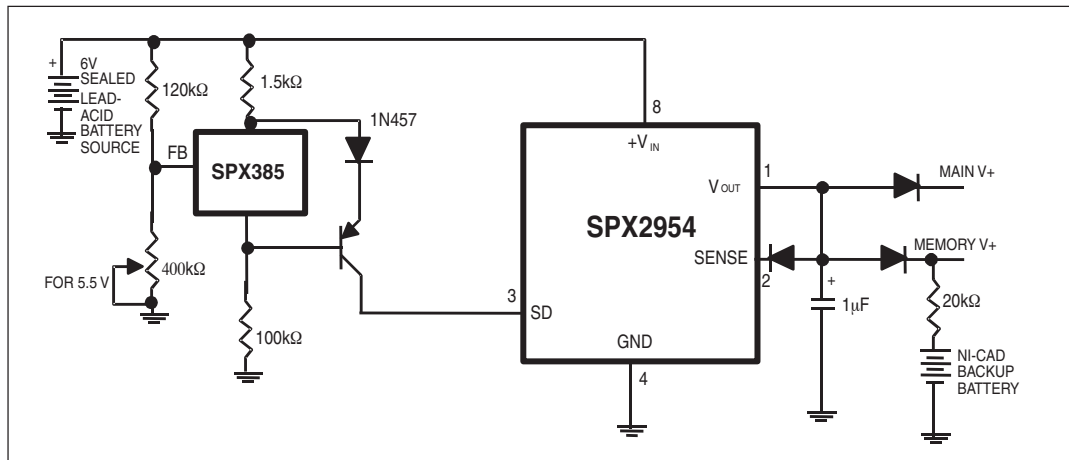

Figure 4. Low Battery Disconnect

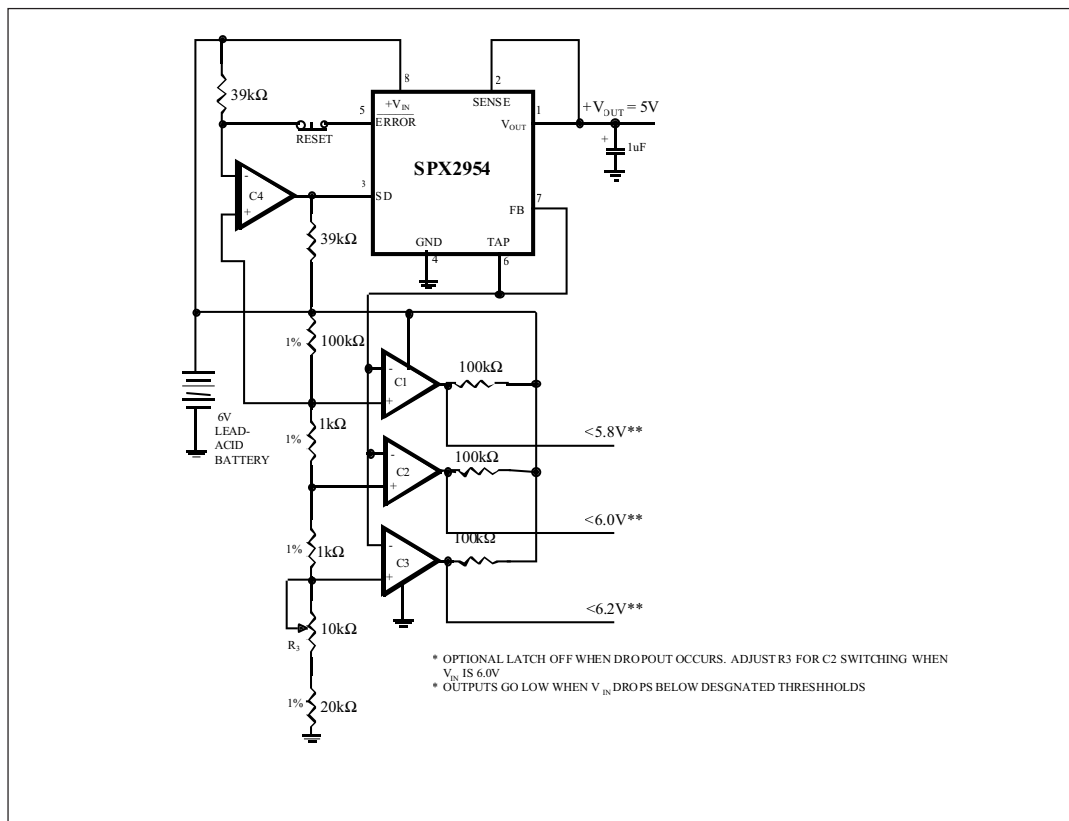

Figure 5. Regulator with State of Charge Indicator

APPLICATIONS HINTS

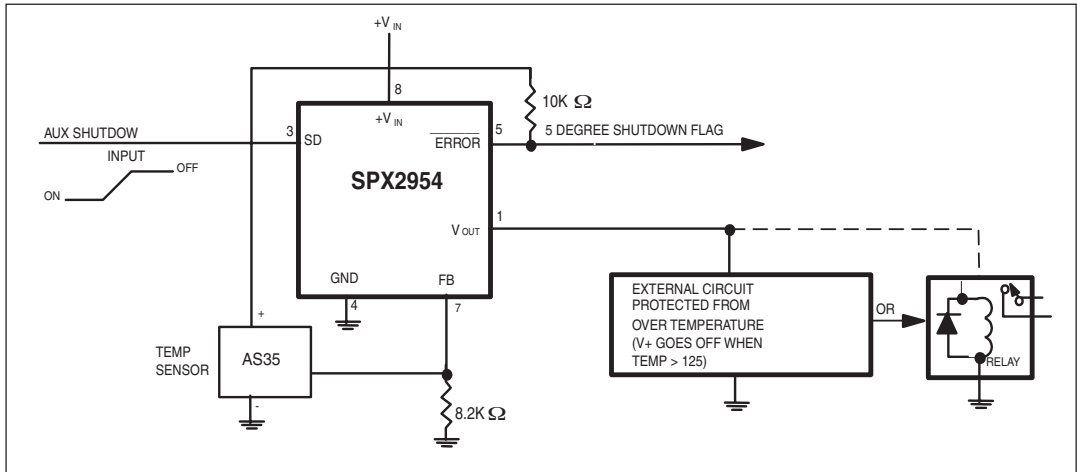

Figure 6. System Over Temperature Protection

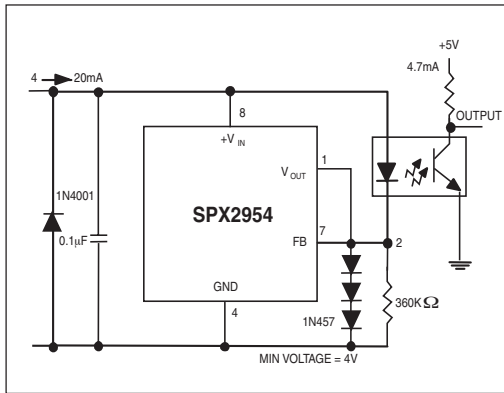

Figure 7. Open Circuit Detector for 4mA to 20mA Current Loop

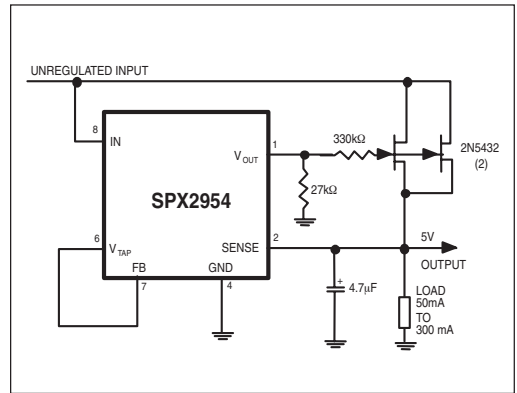
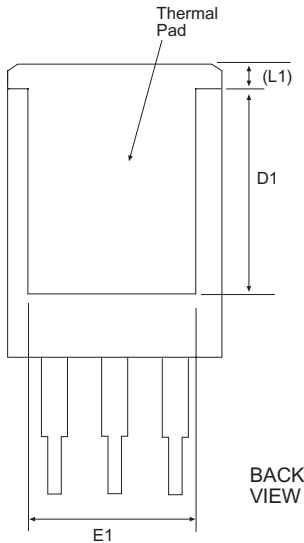
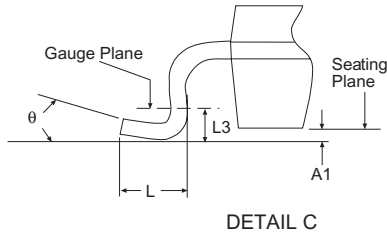
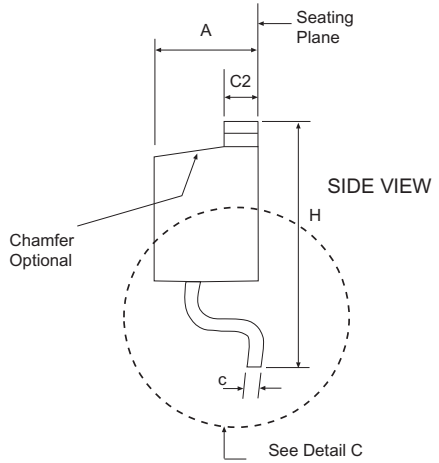
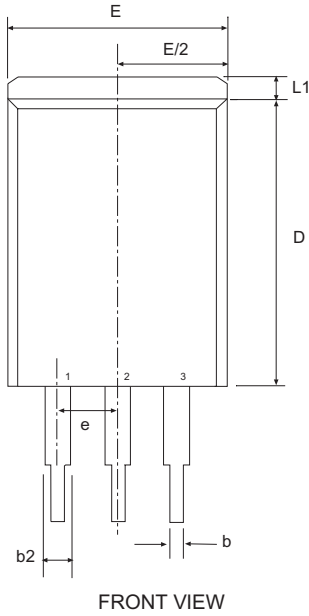
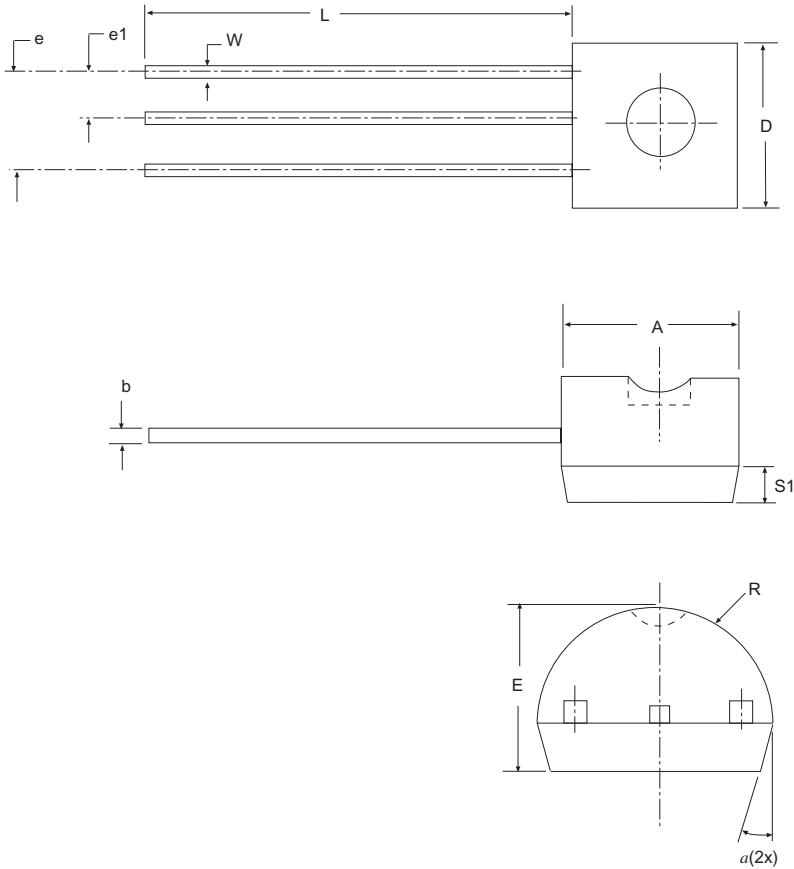

Figure 8. 300mA Regulator with 0.75V



SYMBOL	3 Pin TO-263 JEDEC TO-263			Variation AA		
	Inches Controlling Dimension			Millimeters Conversion Factor: 1 Inch = 25.40 mm		
	MIN	NOM	MAX	MIN	NOM	MAX
A	0.160	-	0.190	4.06	-	4.83
A1	0.000	-	0.010	0.00	-	0.25
b	0.020	-	0.039	0.51	-	0.99
b2	0.045	-	0.070	1.14	-	1.78
c	0.015	-	0.029	0.38	-	0.74
c2	0.045	-	0.065	1.14	-	1.65
D	0.330	-	0.380	8.38	-	9.65
D1	0.270	-	-	6.86	-	-
E	0.380	-	0.420	9.65	-	10.67
E1	0.245	-	-	6.22	-	-
e	.100 BSC			2.54 BSC		
H	0.575	-	0.625	14.61	-	15.88
L	0.070	-	0.110	1.78	-	2.79
L1	-	-	0.066	-	-	1.68
L3	.010 BSC			0.25 BSC		
Ø	0°	-	8°	0°	-	8°
SIPEX Pkg Signoff Date/Rev:				JL Aug5-05 / Rev A		



3 Pin TO-92						
SYMBOL	Dimensions in Inches: Controlling Dimension			Dimensions in Millimeters Conversion Factor: 1 Inch = 25.40 mm		
	MIN	NOM	MAX	MIN	NOM	MAX
A	0.170	-	0.195	4.32	-	4.95
b	0.014	-	0.020	0.36	-	0.51
E	0.130	-	0.155	3.30	-	3.94
e	0.095	-	0.105	2.41	-	2.67
e1	0.045	-	0.055	1.14	-	1.40
L	0.500	-	0.610	12.70	-	15.49
R	0.085	-	0.095	2.16	-	2.41
S1	0.045	-	0.060	1.14	-	1.52
W	0.016	-	0.022	0.41	-	0.56
D	0.175	-	0.195	4.45	-	4.95
α	4°	-	6°	4°	-	6°
SIPEX Pkg Signoff Date/Rev:			JL Sept23-05 / RevA			

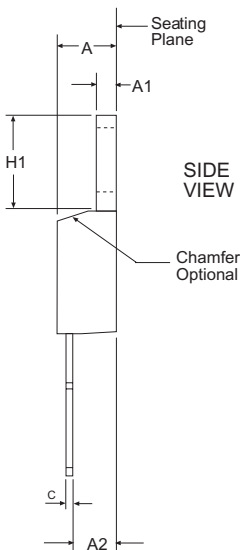
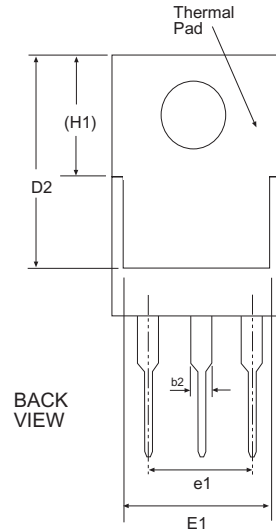
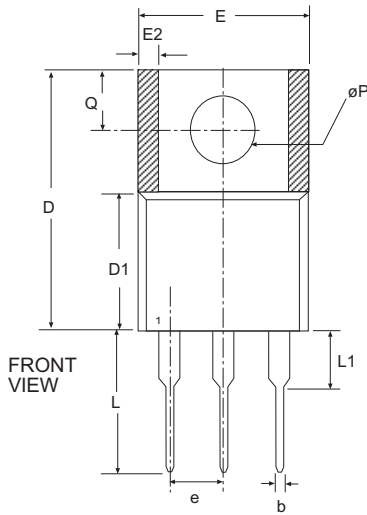

SYMBOL	3 Pin TO-220			JEDEC TO-220			Variation AB		
	Dimensions in Inches: Controlling Dimension			Dimensions in Millimeters: Conversion Factor: 1 Inch = 25.40 mm					
	MIN	NOM	MAX	MIN	NOM	MAX			
A	0.140	-	0.190	3.56	-	4.83			
A1	0.020	-	0.055	0.51	-	1.27			
A2	0.080	-	0.115	2.03	-	2.79			
b	0.015	0.027	0.040	0.25	0.51	1.02			
b2	0.045	0.057	0.070	1.14	1.45	1.78			
c	0.014	-	0.024	0.25	-	0.51			
D	0.560	-	0.650	14.22	-	16.51			
D1	0.330	-	0.355	8.38	-	8.89			
D2	0.480	-	0.507	12.19	-	12.70			
E	0.380	-	0.420	9.65	-	10.67			
E1	0.270	-	0.350	6.86	-	8.89			
E2	-	-	0.030	-	-	0.76			
e	.100 BSC			2.54 BSC					
e1	.200 BSC			5.08 BSC					
H1	0.230	-	0.270	5.84	-	6.86			
L	0.500	-	0.580	12.70	-	14.73			
L1	-	-	0.250	-	-	6.35			
ϕP	0.139	-	0.161	3.30	-	4.06			
Q	0.100	-	0.135	2.54	-	3.30			
SIPEX Pkg Signoff Date/Rev:				JL Aug4-05 / Rev A					

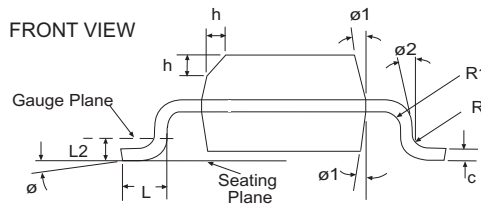
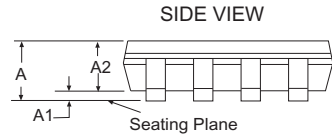
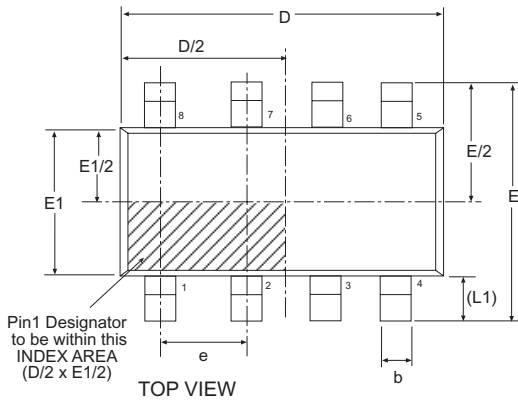

8 Pin NSOIC		JEDEC MS-012		Variation AA		
SYMBOL	Dimensions in Millimeters: Controlling Dimension			Dimensions in Inches Conversion Factor: 1 Inch = 25.40 mm		
	MIN	NOM	MAX	MIN	NOM	MAX
A	1.35	-	1.75	0.053	-	0.069
A1	0.10	-	0.25	0.004	-	0.010
A2	1.25	-	1.65	0.049	-	0.065
b	0.31	-	0.51	0.012	-	0.020
c	0.17	-	0.25	0.007	-	0.010
E	6.00 BSC			0.236 BSC		
E1	3.90 BSC			0.154 BSC		
e	1.27 BSC			0.050 BSC		
h	0.25	-	0.50	0.010	-	0.020
L	0.40	-	1.27	0.016	-	0.050
L1	1.04 REF			0.041 REF		
L2	0.25 BSC			0.010 BSC		
R	0.07	-	-	0.003	-	-
R1	0.07	-	-	0.003	-	-
theta	0°	-	8°	0°	-	8°
phi1	5°	-	15°	5°	-	15°
phi2	0°	-	-	0°	-	-
D	4.90 BSC			0.193 BSC		
SIPEX Pkg Signoff Date/Rev:				JL Aug16-05 / Rev A		

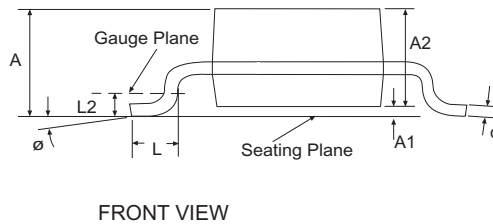
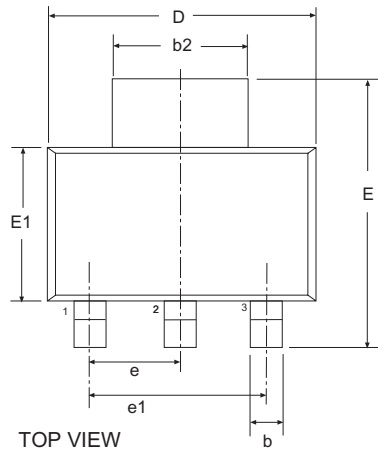

3 Pin SOT-223		JEDEC TO-261		Variation AA		
SYMBOL	Millimeters Controlling Dimension			Inches Conversion Factor: 1 Inch = 25.40 mm		
	MIN	NOM	MAX	MIN	NOM	MAX
A	-	-	1.80	-	-	0.071
A1	0.02	-	0.10	0.001	-	0.004
A2	1.50	1.60	1.70	0.060	0.063	0.067
b	0.66	0.76	0.84	0.026	0.030	0.033
b2	2.90	3.00	3.10	0.114	0.118	0.122
c	0.23	0.30	0.35	0.010	0.012	0.014
D	6.30	6.50	6.70	0.248	0.256	0.264
E	6.70	7.00	7.30	0.264	0.276	0.287
E1	3.30	3.50	3.70	0.130	0.138	0.146
e	2.30 BASIC			0.091 BASIC		
e1	4.60 BASIC			0.182 BASIC		
L	0.75	-	-	0.030	-	-
L2	0.25 BASIC			0.010 BASIC		
ø	0°	-	10°	0°	-	10°
SIPEX Pkg Signoff Date/Rev:				JL Aug8-05/Rev A		

ORDERING INFORMATION

PART NUMBER	ACCURACY	OUTPUT VOLTAGE	PACKAGE
SPX2954AT-3-3	0.5%	3.3V	3 lead TO-263
SPX2954AT-5-0	0.5%	5.0V	3 lead TO-263
SPX2954T-3-3	1%	3.3V	3 lead TO-263
SPX2954T-5-0	1%	5.0V	3 lead TO-263
SPX2954AN-3-3	0.5%	3.3V	3 lead TO-92
SPX2954AN-5-0	0.5%	5.0V	3 lead TO-92
SPX2954N-3-3	1%	3.3V	3 lead TO-92
SPX2954N-5-0	1%	5.0V	3 lead TO-92
SPX2954AU-3-3	0.5%	3.3V	3 lead TO-220
SPX2954AU-5-0	0.5%	5.0V	3 lead TO-220
SPX2954U-3-3	1%	3.3V	3 lead TO-220
SPX2954U-5-0	1%	5.0V	3 lead TO-220
SPX2954AS-3-3	0.5%	3.3V	8 lead SOIC
SPX2954AS-5-0	0.5%	5.0V	8 lead SOIC
SPX2954S-3-3	1%	3.3V	8 lead SOIC
SPX2954S-5-0	1%	5.0V	8 lead SOIC
SPX2954AM3-3-3	0.5%	3.3V	3 lead SOT-223
SPX2954AM3-5-0	0.5%	5.0V	3 lead SOT-223
SPX2954M3-3-3	1%	3.3V	3 lead SOT-223
SPX2954M3-5-0	1%	5.0V	3 lead SOT-223

Please consult the factory for pricing and availability on a Tape-On-Reel option.



ANALOG EXCELLENCE

Sipex Corporation

Headquarters and
Sales Office

233 South Hillview Drive
Milpitas, CA 95035
TEL: (408) 934-7500
FAX: (408) 935-7600

Sipex Corporation reserves the right to make changes to any products described herein. Sipex does not assume any liability arising out of the application or use of any product or circuit described herein; neither does it convey any license under its patent rights nor the rights of others.