

SURFACE MOUNT SCHOTTKY BARRIER RECTIFIER

VOLTAGE 200 Volts CURRENT 15.0 Amperes

FEATURES

- * Low Profile Design for Smart Phone Charger
- * Ideal for SMT Mounting
- * High Forward Surge Capability
- * Low Forward Voltage Drop
- * Excellent High Temperature Stability

MECHANICAL DATA

- * Epoxy: Device has UL flammability classification 94V-0
- * Halogen-free

MAXIMUM RATINGS AND ELECTRICAL CHARACTERISTICS

Ratings at 25 °C ambient temperature unless otherwise specified.
Single phase, resistive or inductive load.

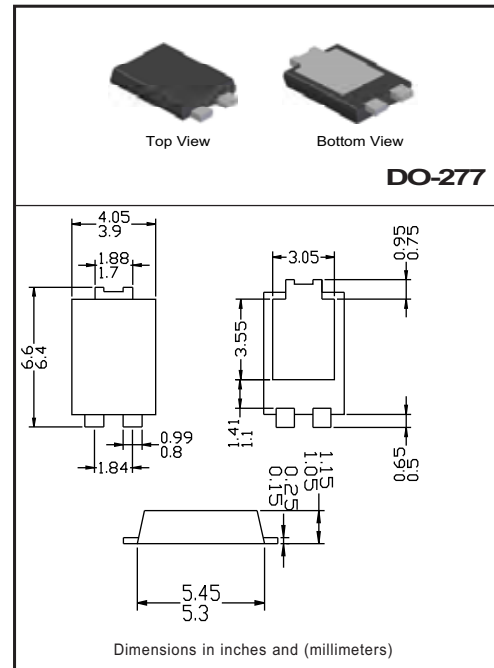

MAXIMUM RATINGS (@ TA=25 °C unless otherwise noted)

RATINGS	SYMBOL	SR15200P	UNITS
Maximum Recurrent Peak Reverse Voltage	V_{RRM}	200	Volts
Maximum RMS Voltage	V_{RMS}	140	Volts
Maximum DC Blocking Voltage	V_{DC}	200	Volts
Maximum Average Forward Rectified Current at Derating Case Temperature	I_O	15	Amps
Peak Forward Surge Current 8.3 ms single half sine-wave superimposed on rated load (JEDEC method)	I_{FSM}	300	Amps
Typical Current Square Time	I^2T	373.5	A ² S
Typical Thermal Resistance (Note 1)	$R_{\theta JC}$	15	°C/W
	$R_{\theta JL}$	5	
Operating Temperature Range	T_J	-55 to + 175	°C
Storage Temperature Range	T_{STG}	-55 to + 175	°C

ELECTRICAL CHARACTERISTICS (@TA=25 °C unless otherwise noted)

CHARACTERISTICS	SYMBOL	SR15200P	UNITS	
Maximum Instantaneous Forward Voltage at 15.0A DC	V_F	.90	Volts	
Maximum Average Reverse Current at Rated DC Blocking Voltage	I_R	@ $T_A = 25^\circ C$	5	uA
		@ $T_A = 150^\circ C$	10	mA

NOTES : 1. Thermal Resistance : Mounted on PCB.
2. "ROHS compliant".

2019-11
REV:0

RATING AND CHARACTERISTICS CURVES (SR15200P)

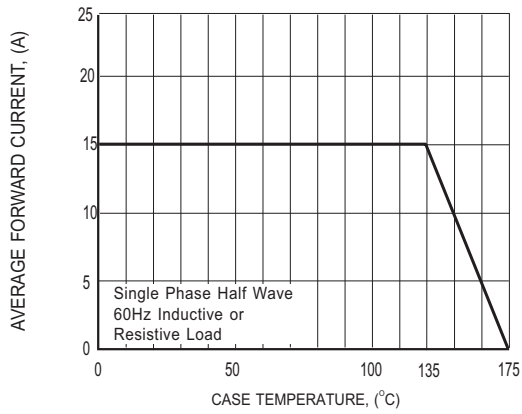

FIG.1 TYPICAL FORWARD CURRENT DERATING CURVE

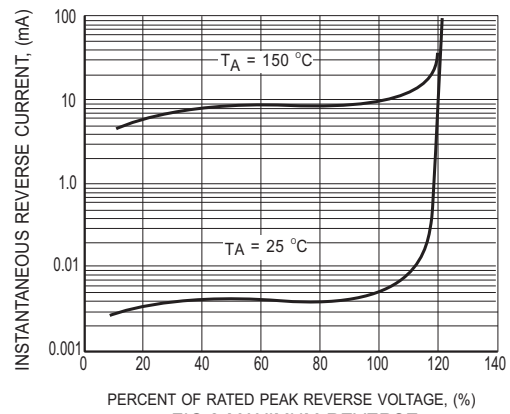

FIG.2 MAXIMUM REVERSE CHARACTERISTICS

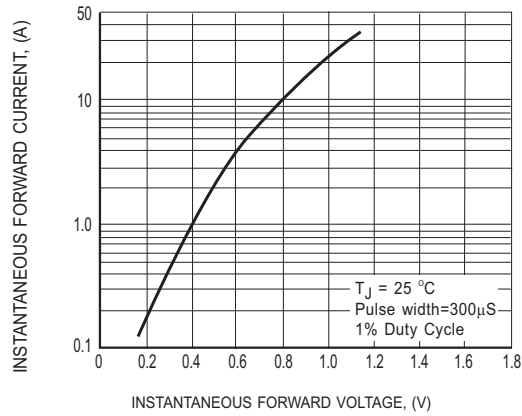

FIG.3 MAXIMUM INSTANTANEOUS FORWARD CHARACTERISTICS

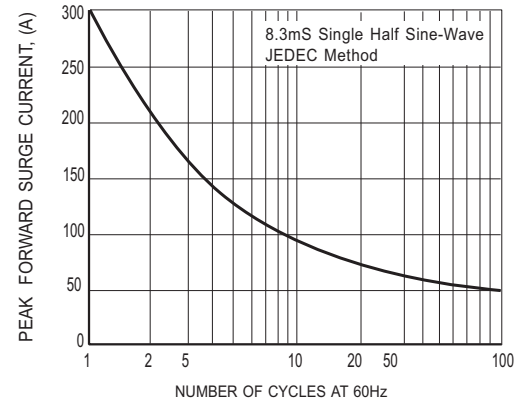
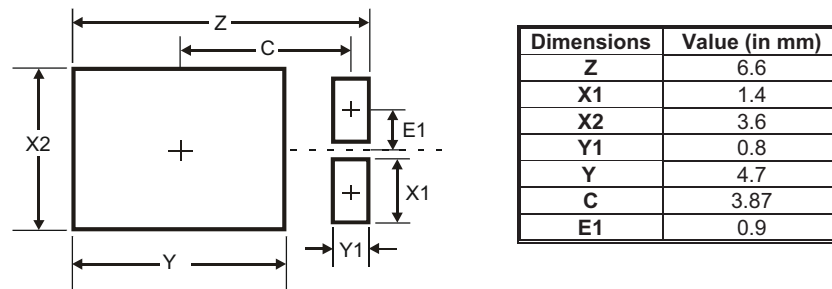

FIG.4 MAXIMUM NON-REPETITIVE FORWARD SURGE CURRENT

Recommendation of Mounting Pad Layout



Dimensions in millimeters

Marking Description

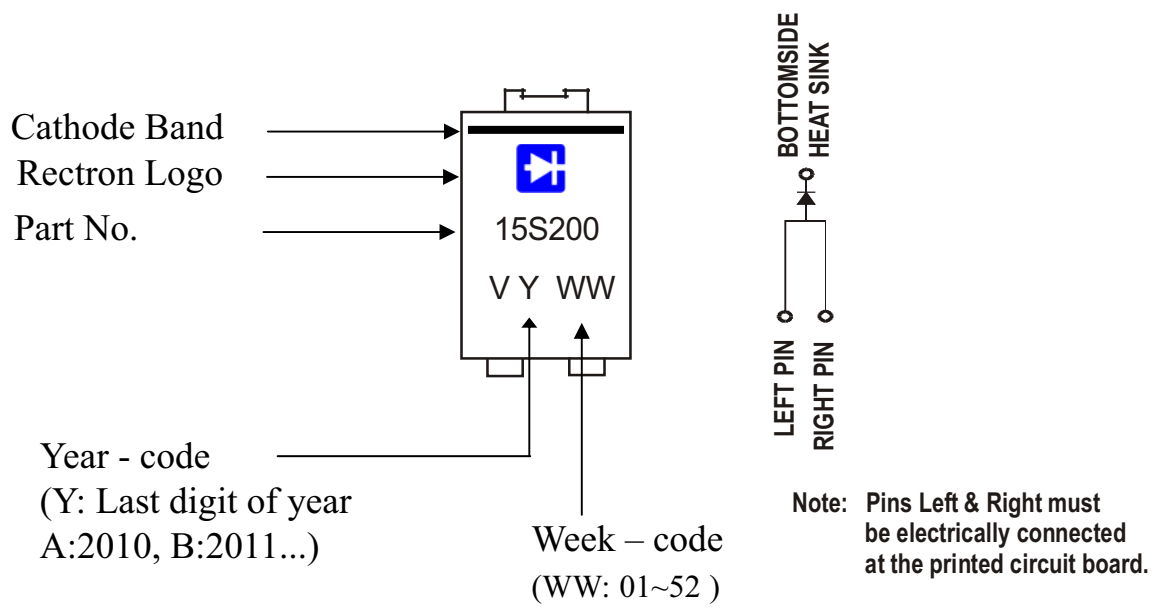

REEL TAPING SPECIFICATIONS FOR SURFACE MOUNT DEVICES-FLAT MELF (DO-277)

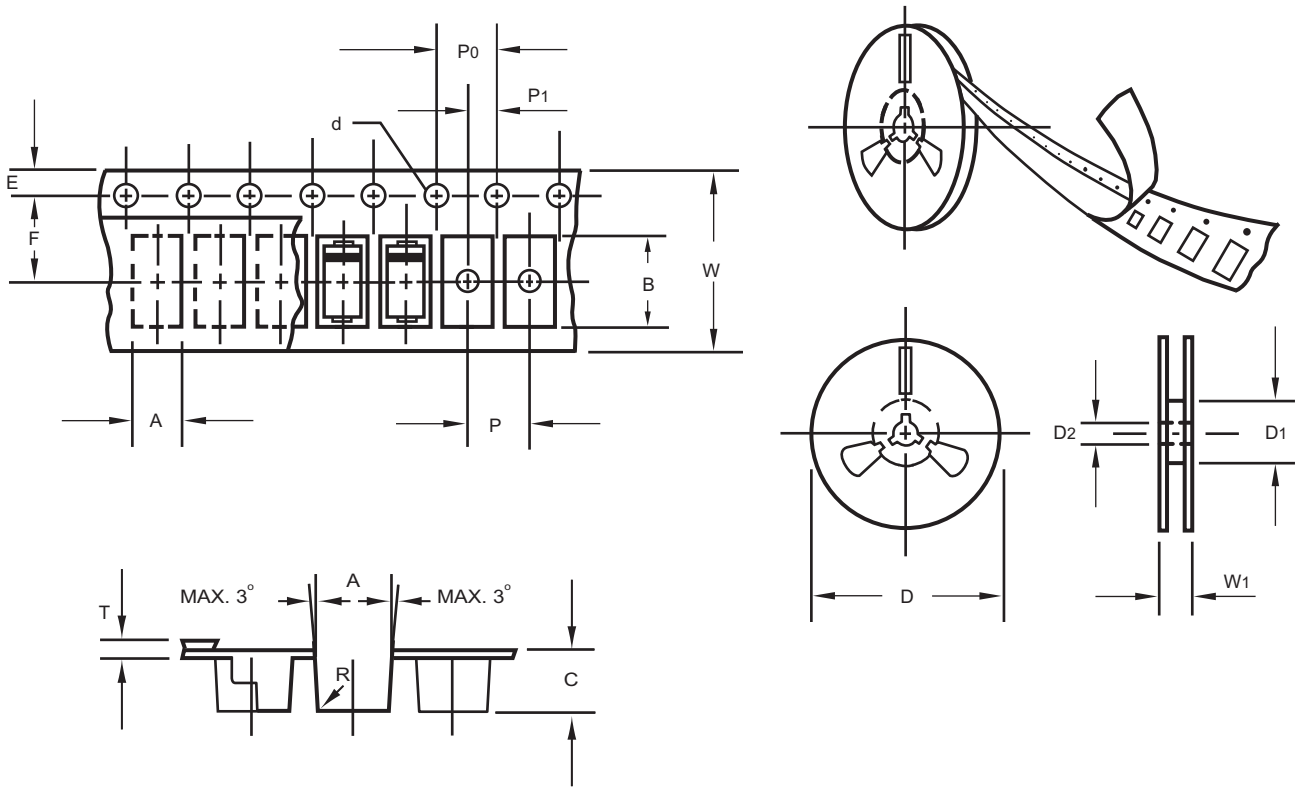
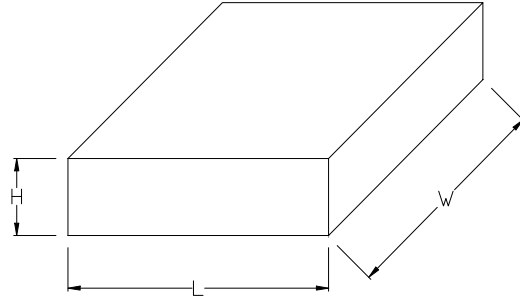

Fig.: Configuration of FLAT MELF TAPING
(DO-277)

ITEM	SYMBOL	DO-277 mm(inch)	
Carrier width	A	5.45 ± 0.1 (0.179 ± 0.004)	
Carrier length	B	6.80 ± 0.1 (0.268 ± 0.004)	
Carrier depth	C	1.33 ± 0.1 (0.052 ± 0.004)	
Sprocket hole	d	1.5 ± 0.1 (0.059 ± 0.004)	
Reel outside diameter	D	178 ± 2.0 (7.0 ± 0.079)	
Reel inner diameter	D1	50 Min.	
Feed hole diameter	D2	13 ± 0.5 (0.512 ± 0.020)	
Sprocket hole position	E	1.75 ± 0.1 (0.069 ± 0.004)	
Punch hole position	F	5.50 ± 0.05 (0.217 ± 0.002)	
Punch hole pitch	P	8.0 ± 0.1 (0.315 ± 0.004)	
Sprocket hole pitch	P0	4.0 ± 0.1 (0.157 ± 0.004)	
Embossment center	P1	2.00 ± 0.05 (0.079 ± 0.002)	
Total tape thickness	T	0.28 ± 0.02 (0.011 ± 0.001)	
Tape width	W	12.00 + 0.3 (0.472 + 0.012)	12.00 - 0.1 (0.472 - 0.004)
Reel width	W1	16.8 ± 2.0 (0.661 ± 0.079)	

Note: 1.Devices are packed in accordance with EIA standard RS-481-A and specification given above.

1. BOX



Packing Code	L (mm)	W (mm)	H (mm)
-T/W	338	338	40

2. REEL

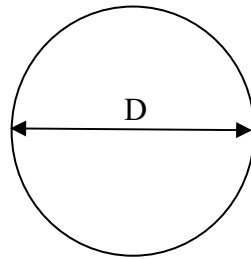

Packing Code	D (mm)
-T/W	330

3. CARTON

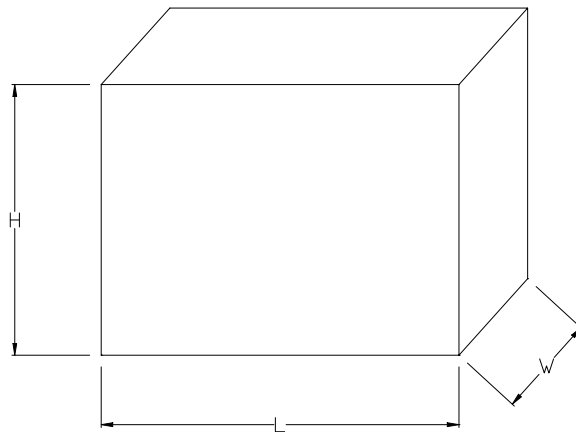

Packing Code	L (mm)	W (mm)	H (mm)
-T/W	360	355	360

PACKAGING OF DIODE AND BRIDGE RECTIFIERS

REEL PACK

PACKAGE	PACKING CODE	EA PER REEL	EA PER INNER BOX	COMPONENT SPACE (mm)	TAPE SPACE (mm)	REEL DIA (mm)	CARTON SIZE (mm)	EA PER CARTON	GROSS WEIGHT(Kg)
DO-277	-T/W	5,000	10,000	---	---	330	360*355*360	80,000	15.29

DISCLAIMER NOTICE

Rectron Inc reserves the right to make changes without notice to any product specification herein, to make corrections, modifications, enhancements or other changes. Rectron Inc or anyone on its behalf assumes no responsibility or liability for any errors or inaccuracies. Data sheet specifications and its information contained are intended to provide a product description only. "Typical" parameters which may be included on RECTRON data sheets and/ or specifications can and do vary in different applications and actual performance may vary over time. Rectron Inc does not assume any liability arising out of the application or use of any product or circuit.

Rectron products are not designed, intended or authorized for use in medical, life-saving implant or other applications intended for life-sustaining or other related applications where a failure or malfunction of component or circuitry may directly or indirectly cause injury or threaten a life without expressed written approval of Rectron Inc. Customers using or selling Rectron components for use in such applications do so at their own risk and shall agree to fully indemnify Rectron Inc and its subsidiaries harmless against all claims, damages and expenditures.