



SCHOTTKY BARRIER RECTIFIER

SRF1620 THRU SRF16200

VOLTAGE RANGE

20 to 100 Volts

CURRENT

16.0 Amperes

FEATURES

- Metal of silicon rectifier, majority carrier conduction
- Guard ring for transient protection
- Low power loss, high efficiency
- High current capability low VF
- High surge capacity
- Plastic package has UL flammability classification 94V-O
- For use in low voltage, high frequency inverters. Free wheeling, and polarity protection applications

MECHANICAL DATA

- Case: ITO-220AC full molded plastic
- Polarity: As marked on the body
- Weight: 0.08 ounces, 2.24 grams
- Mounting position: Any

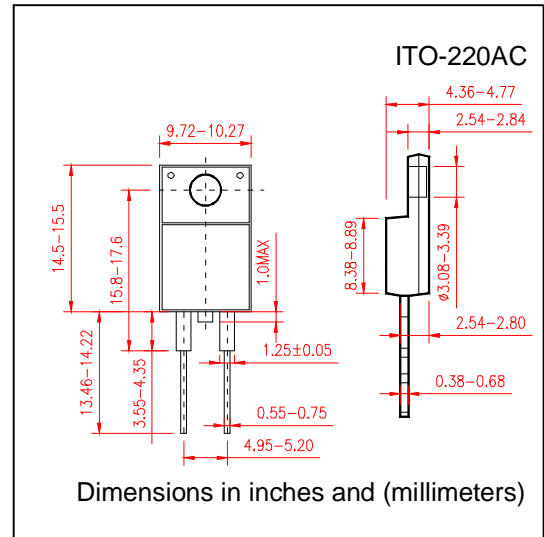

MAXIMUM RATINGS AND ELECTRICAL CHARACTERISTICS

- Ratings at 25°C ambient temperature unless otherwise specified
- Single Phase, half wave, 60Hz, resistive or inductive load
- For capacitive load derate current by 20%

	SYMBOLS	SRF 1620	SRF 1630	SRF 1635	SRF 1640	SRF 1645	SRF 1650	SRF 1660	SRF 1680	SRF 16100	SRF 16150	SRF 16200	UNIT	
Maximum Repetitive Peak Reverse Voltage	V_{RRM}	20	30	35	40	45	50	60	80	100	150	200	Volts	
Maximum RMS Voltage	V_{RMS}	14	21	25	28	32	35	42	56	70	105	140	Volts	
Maximum DC Blocking Voltage	V_{DC}	20	30	35	40	45	50	60	80	100	150	200	Volts	
Maximum Average Forward Rectified Current(See Fig.1) @T _c =100°C	$I_{(AV)}$	16.0											Amps	
Peak Forward Surge Current 8.3ms single half sine wave superimposed on rated load (JEDEC method)	I_{FSM}	150											Amps	
Maximum Forward Voltage (NOTE1)I _F =16A@T _J =25°C	V_F	0.65				0.75				0.85				Volts
Maximum DC Reverse Current at rated DC Blocking Voltage	T _C = 25°C	0.5											mA	
	T _C = 100°C	100												
Typical Thermal Resistance (Note 2)	C_J	500											pF	
Typical Junction Capacitance(Note3)	$R_{\theta JC}$	2.0											°C/W	
Operating and Storage Temperature Range	T _J T _{STG}	(-55 to +150)											°C	

Notes:

1. Thermal Resistance Junction to Case
2. 300 μ s Pulse width, 2% duty cycle
3. Measured at 1.0MHz and applied reverse voltage of 4.0V DC



SCHOTTKY BARRIER RECTIFIER

SRF1620 THRU SRF16200

VOLTAGE RANGE 20 to 100 Volts
CURRENT 16.0 Ampere

RATING AND CHARACTERISTIC CURVES SRF1620 THRU SRF16100

