



SS22BF THRU SS2200BF

Reverse Voltage - 20 to 200 Volts Forward Current - 2.0 Ampere

SURFACE MOUNT SCHOTTKY BARRIER RECTIFIER

Features

- ◆ Metal silicon junction, majority carrier conduction
- ◆ For surface mounted applications
- ◆ Low power loss,high efficiency
- ◆ High forward surge current capability
- ◆ For use in low voltage,high frequency inverters, free wheeling,and polarity protection applications

Mechanical Data

Case: JEDEC $\dot{U}T B\dot{O}$ molded plastic body
 Terminals: Solderable per MIL-STD-750,Method 2026A
 Polarity: Polarity symbol marking on body Mounting
 Position: Any
 Weight : 0.002 ounce, 0.057 grams

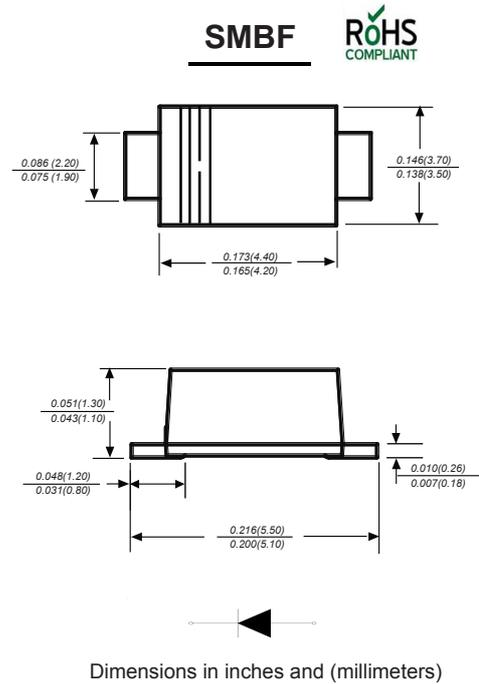

Maximum Ratings And Electrical Characteristics

Ratings at 25° C ambient temperature unless otherwise specified.
 Single phase half-wave 60Hz, resistive or inductive load, for capacitive load current derate by 20%.

Parameter	SYMBOLS	SS22BF	SS23BF	SS24BF	SS25BF	SS26BF	SS28BF	SS210BF	SS2150BF	SS2200BF	UNITS
		MDD SS22BF	MDD SS23BF	MDD SS24BF	MDD SS25BF	MDD SS26BF	MDD SS28BF	MDD SS210BF	MDD SS2150BF	MDD SS2200BF	
Maximum repetitive peak reverse voltage	V_{RMM}	20	30	40	50	60	80	100	150	200	V
Maximum RMS voltage	V_{RMS}	14	21	28	35	42	56	70	105	140	V
Maximum DC blocking voltage	V_{DC}	20	30	40	50	60	80	100	150	200	V
Maximum average forward rectified current at TL(see fig.1)	$I_{(AV)}$	2.0									A
Peak forward surge current 8.3ms single half sine-wave superimposed on rated load (JEDEC Method)	I_{FSM}	55					45				A
Maximum instantaneous forward voltage at 2.0A	V_F	0.55			0.70		0.85		0.95		V
Maximum DC reverse current $T_A=25^{\circ}C$ at rated DC blocking voltage $T_A=125^{\circ}C$	I_R	0.5					0.3				mA
		20.0					3.0				
Typical junction capacitance (NOTE 1)	C_J	250					110				pF
Typical thermal resistance (NOTE 2)	$R_{\theta JA}$	65.0									$^{\circ}C/W$
Operating junction temperature range	T_J	-55 to +125									$^{\circ}C$
Storage temperature range	T_{STG}	-55 to +150									$^{\circ}C$

Note: 1. Measured at 1.0MHz and applied reverse voltage of 4.0V D.C.
 2. P.C.B. mounted with 2.0x2.0"(5.0x5.0cm) copper pad areas.
 3. The typical data above is for reference only.



SS22BF THRU SS2200BF

Reverse Voltage - 20 to 200 Volts Forward Current - 2.0 Ampere

Typical Characteristics

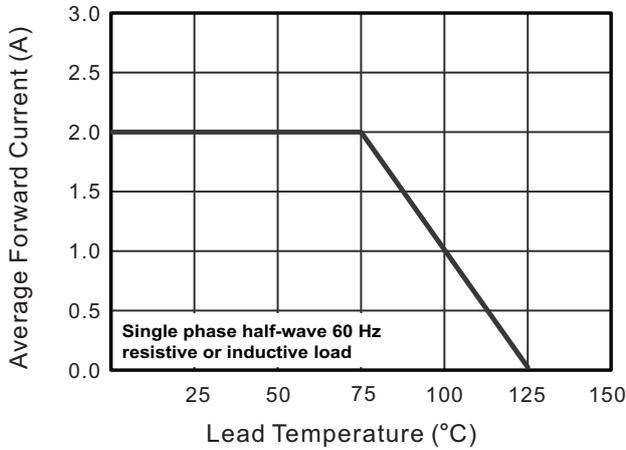

Fig.3 Typical Forward Characteristic

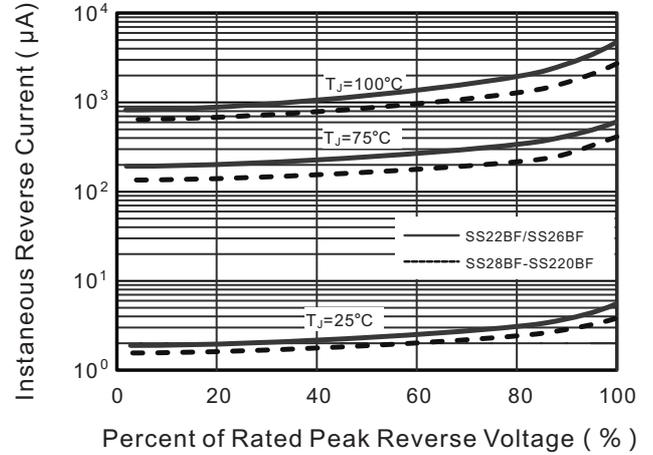

Fig.4 Typical Junction Capacitance

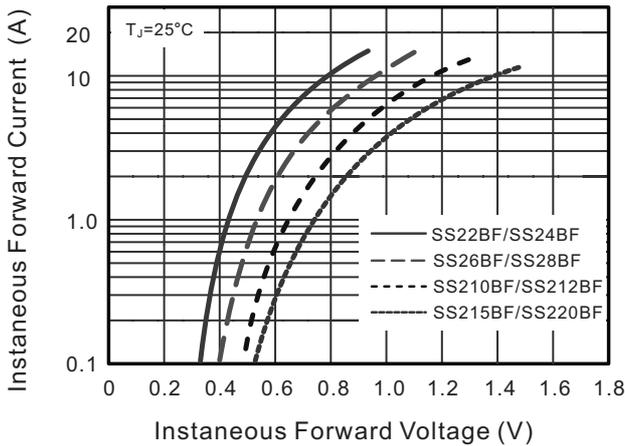

Fig.5 Maximum Non-Repetitive Peak Forward Surge Current

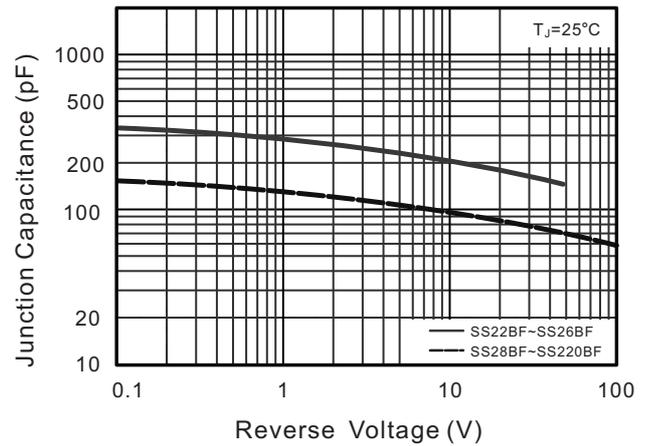
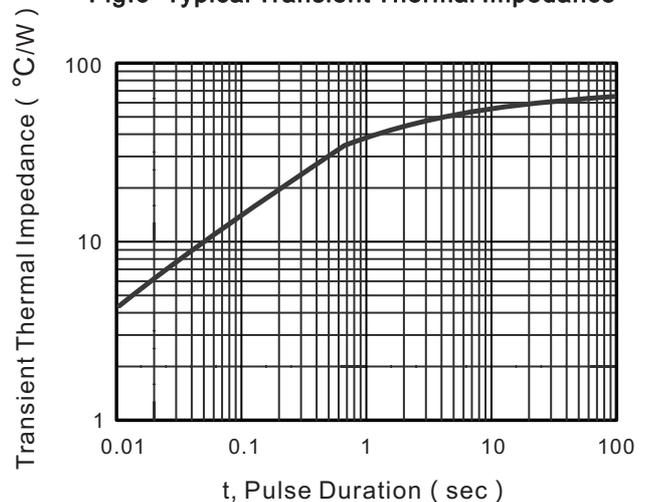
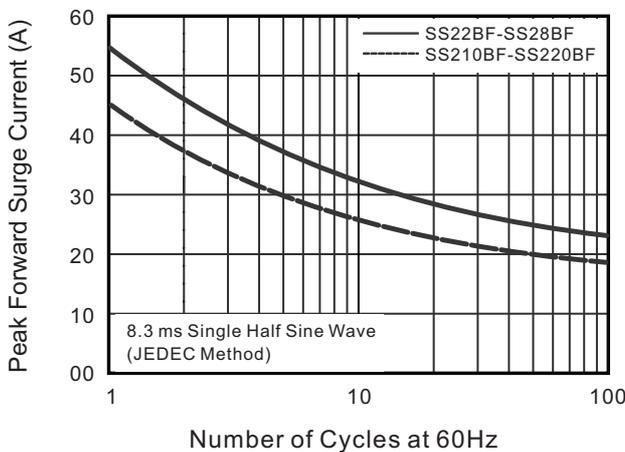

Fig.6- Typical Transient Thermal Impedance



The curve above is for reference only.



SS22BF THRU SS2200BF

Reverse Voltage - 20 to 200 Volts Forward Current - 2.0 Ampere

Packing information

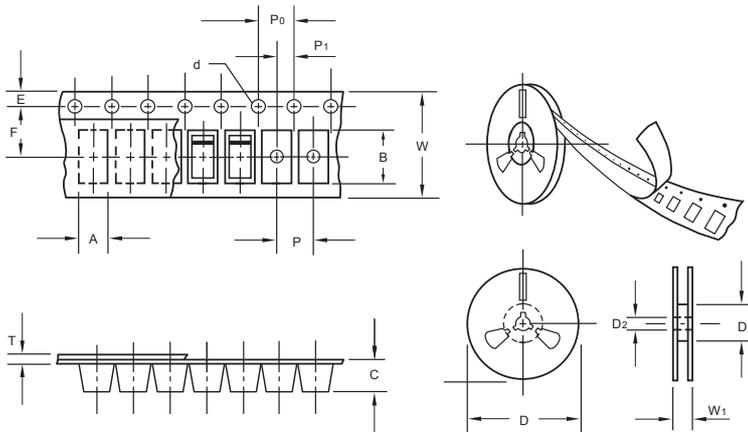

unit:mm

Item	Symbol	Tolerance	SMBF
Carrier width	A	0.1	3.81
Carrier length	B	0.1	5.61
Carrier depth	C	0.1	1.60
Sprocket hole	d	0.05	1.50
13" Reel outside diameter	D	2.0	330.00
13" Reel inner diameter	D ₁	min	50.00
Feed hole diameter	D ₂	0.5	13.00
Sprocket hole position	E	0.1	1.75
Punch hole position	F	0.1	5.50
Punch hole pitch	P	0.1	4.00
Sprocket hole pitch	P ₀	0.1	4.00
Embossment center	P ₁	0.1	2.00
Overall tape thickness	T	0.1	0.30
Tape width	W	0.3	12.00
Reel width	W ₁	1.0	12.30

Note: Devices are packed in accordance with EIA standard RS-481-A and specifications listed above.

Reel packing

PACKAGE	REEL SIZE	REEL (pcs)	COMPONENT SPACING (mm)	BOX (pcs)	INNER BOX (mm)	REEL DIA. (mm)	CARTON SIZE (mm)	CARTON (pcs)	APPROX. GROSS WEIGHT (kg)
SMBF	13"	5,000	4.0	10,000	190*190*41	330	365*365*360	80,000	14.0

Suggested Pad Layout

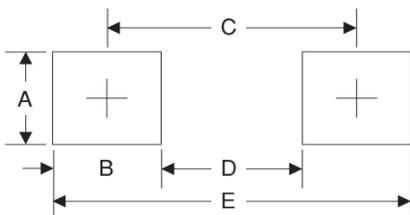

Symbol	Unit (mm)	Unit (inch)
A	2.54	0.100
B	1.8	0.071
C	4.8	0.189
D	3.0	0.118
E	6.6	0.260

Important Notice and Disclaimer

Microdiode Electronics (Jiangsu) reserves the right to make changes to this document and its products and specifications at any time without notice. Customers should obtain and confirm the latest product information and specifications before final design, purchase or use.

Microdiode Electronics (Jiangsu) makes no warranty, representation or guarantee regarding the suitability of its products for any particular purpose, nor does Microdiode Electronics (Jiangsu) assume any liability for application assistance or customer product design. Microdiode Electronics (Jiangsu) does not warrant or accept any liability with products which are purchased or used for any unintended or unauthorized application.

No license is granted by implication or otherwise under any intellectual property rights of Microdiode Electronics (Jiangsu).

Microdiode Electronics (Jiangsu) products are not authorized for use as critical components in life support devices or systems without express written approval of Microdiode Electronics (Jiangsu).