

1. PART NO. EXPRESSION :

SSC10052R4YZF
 (a) (b) (c) (d)(e)(f)

- (a) Series code
- (b) Dimension code
- (c) Inductance code : 2R4 = 2.4uH
- (d) Tolerance code : Y = ±30%
- (e) X, Y, Z : Standard part
- (f) F : Lead Free

2. CONFIGURATION & DIMENSIONS :

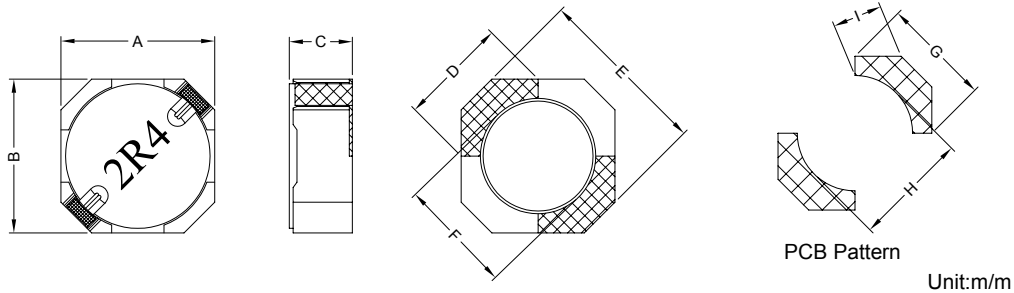

A	B	C	D	E	F	G	H	I
10.00±0.30	10.00±0.30	5.00 Max.	6.80 Ref.	11.50 Ref.	7.70 Ref.	7.30 Ref.	7.20 Ref.	3.50 Ref.

3. SCHEMATIC :

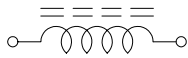

4. MATERIALS :

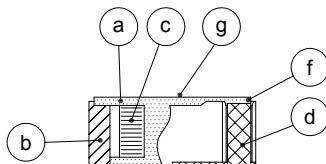

- (a) Core : DR Ferrite Core
- (b) Core : RI Ferrite Core
- (c) Wire : Enamelled Copper Wire
- (d) Terminal : Tinned Copper Plate
- (e) Adhesive : Epoxy
- (f) Adhesive : Epoxy
- (g) Ink : Bon Margue

5. GENERAL SPECIFICATION :

- a) Temp. rise : 40°C Typ. at Irms
- b) ΔL/L0A = 35% Typ. at Isat
- c) Storage temp. : -40°C to +85°C
- d) Operating temp. : -40°C to +105°C
- e) Resistance to solder heat : 260°C.10 secs



RoHS Compliant

NOTE : Specifications subject to change without notice. Please check our website for latest information.

08.05.2008



SUPERWORLD ELECTRONICS (S) PTE LTD

6. ELECTRICAL CHARACTERISTICS :

Part No.	Inductance (μ H)	Test Frequency (Hz)	RDC (m Ω) Max.	Isat (A)	Irms (A)	SRF (MHz) Typ.
SSC10052R4YZF	2.4 \pm 30%	1V / 100K	12.5	11.5	9.6	50.0
SSC10053R6YZF	3.6 \pm 30%	1V / 100K	15.0	9.4	8.2	40.0
SSC10055R0YZF	5.0 \pm 30%	1V / 100K	16.9	8.0	6.8	35.0
SSC10056R6YZF	6.6 \pm 30%	1V / 100K	22.5	7.1	5.7	30.0
SSC10058R5YZF	8.5 \pm 30%	1V / 100K	28.8	6.3	4.8	25.0
SSC1005100YZF	10.0 \pm 30%	1V / 100K	40.0	5.5	4.3	22.0
SSC1005120YZF	12.0 \pm 30%	1V / 100K	42.5	4.9	3.6	20.0
SSC1005150YZF	15.0 \pm 30%	1V / 100K	46.0	4.5	3.4	18.0
SSC1005180YZF	18.0 \pm 30%	1V / 100K	50.0	4.1	3.2	16.0
SSC1005220YZF	22.0 \pm 30%	1V / 100K	56.0	4.0	2.8	15.0
SSC1005270YZF	27.0 \pm 30%	1V / 100K	63.0	3.6	2.7	14.0
SSC1005330YZF	33.0 \pm 30%	1V / 100K	90.0	3.1	2.1	12.0
SSC1005390YZF	39.0 \pm 30%	1V / 100K	105.0	3.0	1.9	11.0
SSC1005470YZF	47.0 \pm 30%	1V / 100K	120.0	2.6	1.8	10.0
SSC1005560YZF	56.0 \pm 30%	1V / 100K	150.0	2.4	1.6	9.0
SSC1005680YZF	68.0 \pm 30%	1V / 100K	175.0	2.1	1.5	8.0
SSC1005820YZF	82.0 \pm 30%	1V / 100K	220.0	2.0	1.3	7.0
SSC1005101YZF	100.0 \pm 30%	1V / 100K	275.0	1.8	1.1	6.0
SSC1005121YZF	120.0 \pm 30%	1V / 100K	312.5	1.6	1.0	5.0



RoHS Compliant

NOTE : Specifications subject to change without notice. Please check our website for latest information.

08.05.2008



SUPERWORLD ELECTRONICS (S) PTE LTD

7. CHARACTERISTICS CURVES :

@ TEMP. RISE VS. DC SUPERPOSITION RESPONSE CURVE

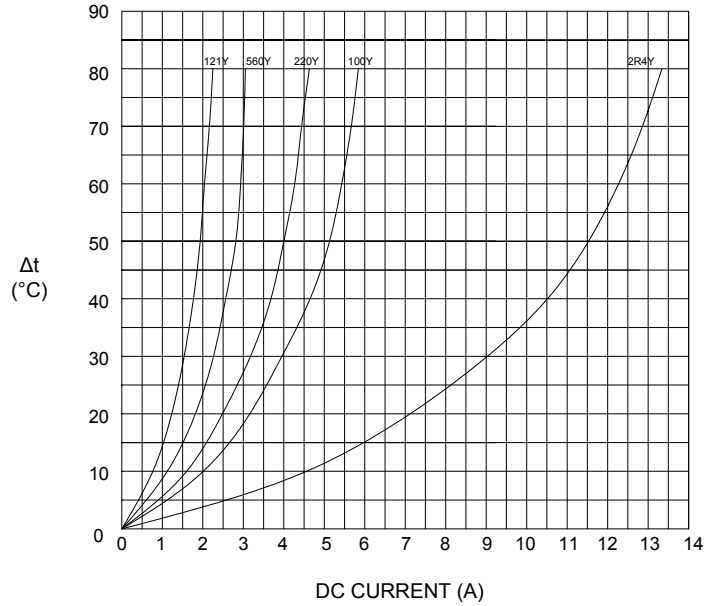

@ INDUCTANCE VS. FREQUENCY RESPONSE CURVE

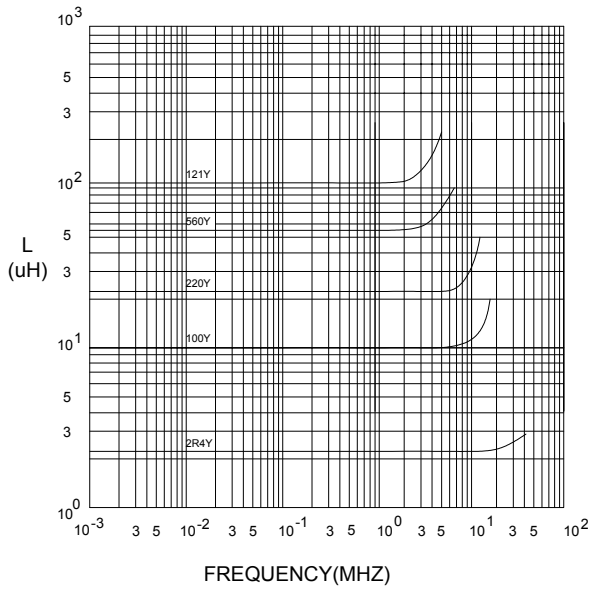

@ INDUCTANCE VS. DC SUPERPOSITION RESPONSE CURVE

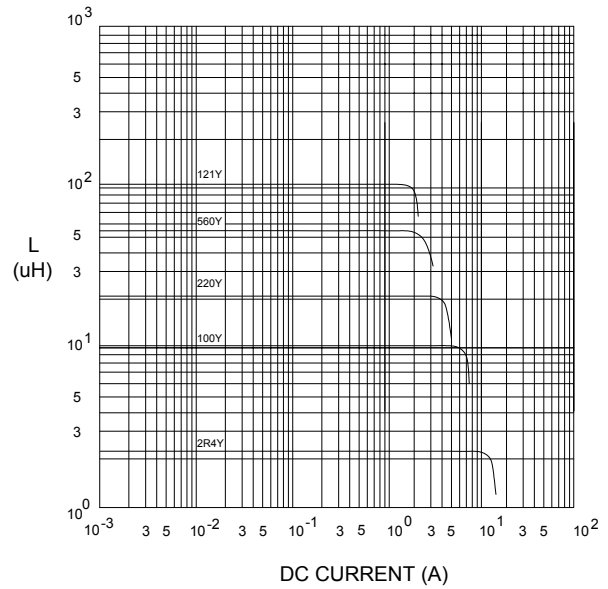

NOTE : Specifications subject to change without notice. Please check our website for latest information.



RoHS Compliant

08.05.2008



SUPERWORLD ELECTRONICS (S) PTE LTD

RECOMMENDED SOLDERING CONDITIONS REFLOW SOLDERINGS

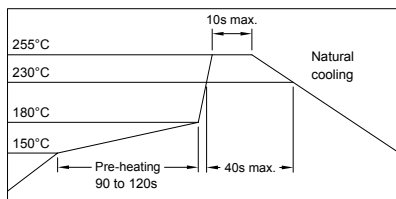

8. PACKAGING INFORMATION :

(1) CONFIGURATION

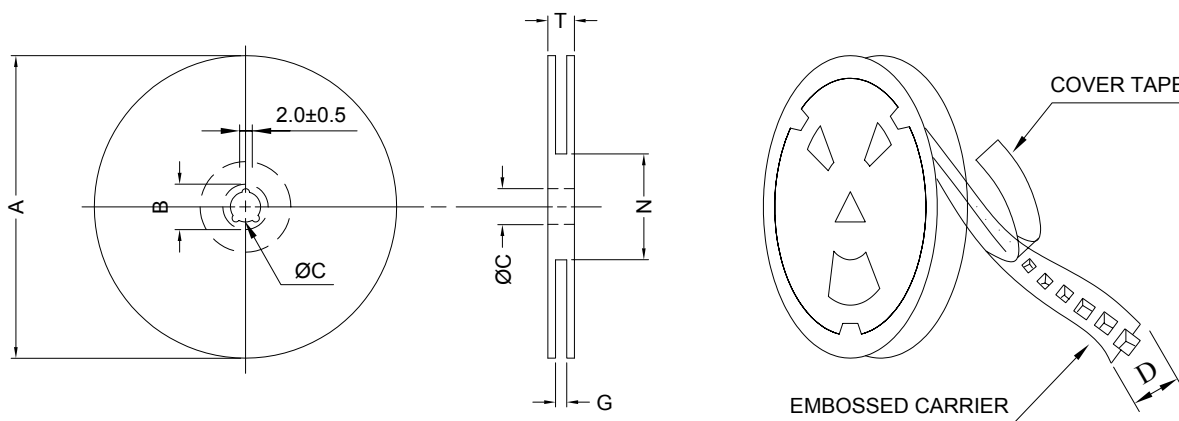

* CARRIER TAPE WIDTH : D

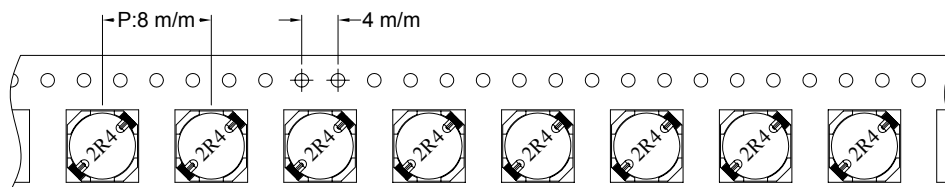

(2) DIMENSIONS

Unit:m/m

STYLE	A	B	C	D	G	N	T
13-24	330	21±0.8	13	24	26 ⁺⁰	50 ⁻⁰	30.4

(3) Q'TY & G.W. PER PACKAGE

SERIES	INNER : REEL			OUTER : CARTON		
	Q'TY (PCS)	G.W. (gw)	STYLE	Q'TY (PCS)	G.W. (Kg)	SIZE (cm)
SSC1005	600	900	13-24	2400	7.1	40 x 40 x 24



RoHS Compliant

NOTE : Specifications subject to change without notice. Please check our website for latest information.

08.05.2008

9. RELIABILITY AND TEST CONDITION :

TEST ITEM	SPECIFICATION	TEST CONDITION
SOLDERABILITY	MORE THAN 90% OF THE TERMINAL ELECTRODE SHALL BE COVERED WITH FRESH SOLDER.	PREHEAT : 125±25°C FOR 60 SECONDS SOLDER : 99%Sn/0.3%Ag/0.7%Cu OR EQUIVALENT SOLDER TEMP. : 245±5°C FLUX : ROSIN DIP TIME : 4±1 SECONDS
THERMAL SHOCK TEST (TEMP. CYCLE)	INDUCTANCE SHALL NOT CHANGE MORE THAN ±20%	ROOM TEMP. → -25±2°C 15 MINUTES → 30 MINUTES ROOM TEMP. → 85±2°C 15 MINUTES → 30 MINUTES TOTAL : 50 CYCLES
HUMIDITY RESISTANCE TEST		TEMPERATURE : 40±2°C HUMIDITY : 90 ~ 95% APPLIED CURRENT : PER SPEC. TIME : 500 HOURS
HIGH TEMP. RESISTANCE TEST		TEMPERATURE : 85±2°C APPLIED CURRENT : PER SPEC. TIME : 500 HOURS

10. UL CARD :

OBMW2		November 30, 2000		
Magnet Wire - Component				
PACIFIC ELECTRIC WIRE & CABLE (SHENZHEN) CO LTD				E201757
607 BAOLONG INDUSTRIAL ESTATE LONGGANG, SHENZHEN GUANGDONG CHINA				
	Coating Type		ANSI	
Mtl Dsg	BC	TC	Type	TI
UEW/U	Polyurethane	—	—	130
PEW/U	Polyester	—	MW5-C	155°C
PEWH/U	Modified Polyester	—	MW30-C	180
PEW-NY/U	Polyester	Polyamide	MW24-C	155
HAI/U	Polyester(Amide)(Imide)	Polyamideimide	MW35,73	200
UEW-NY/U	Polyurethane	Polyamide	MW80-C	155
			MW28-C	130
 Marking: Company name and material designation or marked designation on package or reel, and Recognized Component Mark.				
See General Information Preceding These Recognitions				
1/3/2001	Underwriters Laboratories Inc.		Card 1 of 2	



RoHS Compliant

NOTE : Specifications subject to change without notice. Please check our website for latest information.

08.05.2008



SUPERWORLD ELECTRONICS (S) PTE LTD