

TABLE OF CONTENTS

1.	GENERAL DESCRIPTION	1
2.	FEATURES	1
3.	ORDERING INFORMATION	1
4.	BLOCK DIAGRAM	2
5.	SSD1881Z DIE PAD ASSIGNMENT	3
6.	SSD1881TR TAB PIN ASSIGNMENT	6
7.	SSD1881T1R1 TAB PIN ASSIGNMENT	8
8.	SSD1881T2R TAB PIN ASSIGNMENT	10
9.	PIN DESCRIPTION	12
	VDD_ROW, +V1, VC, -V1 (Power Pin)	12
	YD (Input Pin)	12
	LP (Input Pin)	12
	FR (Input Pin)	12
	F1, F2 (Input Pin)	12
	DOFF# (Input Pin)	12
	SEL (Input Pin)	12
	CIO1, CIO2 (I/O Pin)	12
	SHL (Input Pin)	13
	LSEL (Input Pin)	13
	CSEL (Input Pin)	13
	TEST1 (Input Pin)	13
	TEST2 (Input Pin, only exists on gold-bumped die)	13
	COM0-COM159 (Output Pin)	13
	NCx and DUMCORx (Dummy Pin)	13

10. FUNCTIONAL BLOCK DESCRIPTIONS	14
Controller and Data Register	14
Bi-directional Shift Register	14
Common Cell Level Shifter	14
Timing Diagram For 1/160 duty and 1P operation (DOFF# = H and FR=L).....	15
Timing Diagram For 1/160 duty and 1P operation (DOFF# = H and FR=H)	16
Timing Diagram For 1/160 duty and 1/2P operation (DOFF# = H and FR = L)	17
Timing Diagram For 1/160 duty and 1/2P operation (DOFF# = H and FR = H).....	18
11. MAXIMUM RATINGS.....	19
12. DC CHARACTERISTICS.....	20
13. AC CHARACTERISTICS.....	21
Input Timing Characteristics.....	21
Output Timing Characteristics.....	22
14. APPLICATION EXAMPLE – 160 X 160 LCD SYSTEM.....	23
15. PACKAGE DIMENSION	24

SSD1881

Advance Information

SSD1881 MLA ROW (COMMON) DRIVER CMOS

1. GENERAL DESCRIPTION

The SSD1881 is an MLA (Multi Line Addressing), 160 outputs and triple-value low resistance common driver. Joining with the SSD1730 MLA power chip and the SSD1870 column driver, an MLA LCD module system having high picture quality, high speed responses and low power consumption can be produced. SSD1881 can be configured as 140 outputs or 160 outputs.

2. FEATURES

- Power supply to logic system, 2.7V - 5.5V
- LCD drive voltage, 14V - 30V
- 140 or 160 common outputs
- Drive duty, 1/160 and 1/320
- 1/2P and 1P operation mode
- Adjustable LCD power source offset bias
- Non-biased display off function
- Seletable output shift direction
- Cascade supported
- Available in Gold-bumped die and TAB (Tape Automated Bonding) Package

3. ORDERING INFORMATION

Ordering Part Number	Output lead pitch (mm)	Package Form
SSD1881Z	N/A	Gold Bump Die
SSD1881TR	0.2295	TAB
SSD1881T1R1	0.14	TAB
SSD1881T2R	0.22	TAB

Table 1 - Ordering part number

This document contains information on a new product. Specifications and information herein are subject to change without notice. IC manufactured under Motif license including U.S. Patent No. 5,420,604

4. BLOCK DIAGRAM

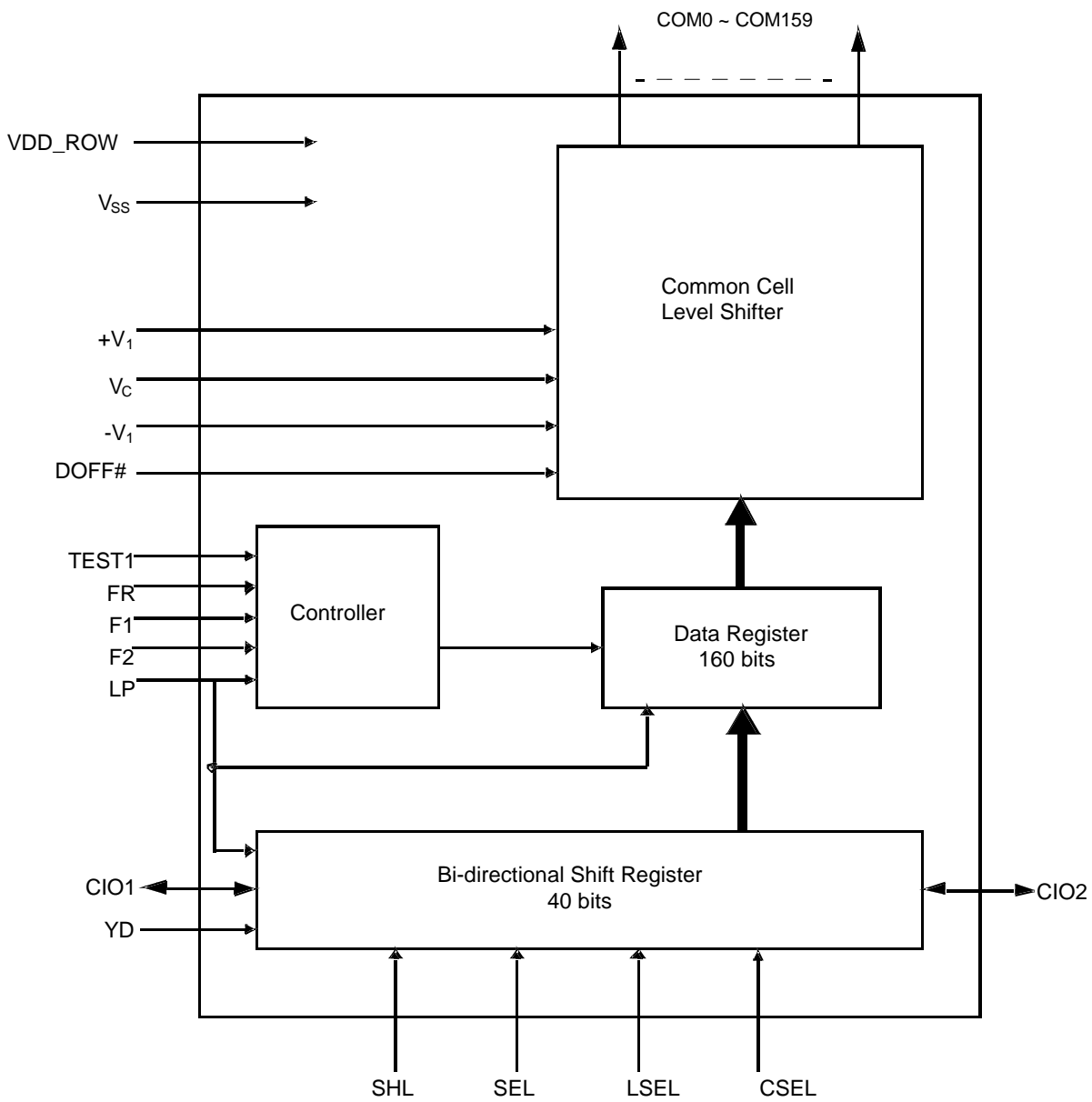

Figure 1 - Block Diagram of SSD1881

5. SSD1881Z DIE PAD ASSIGNMENT

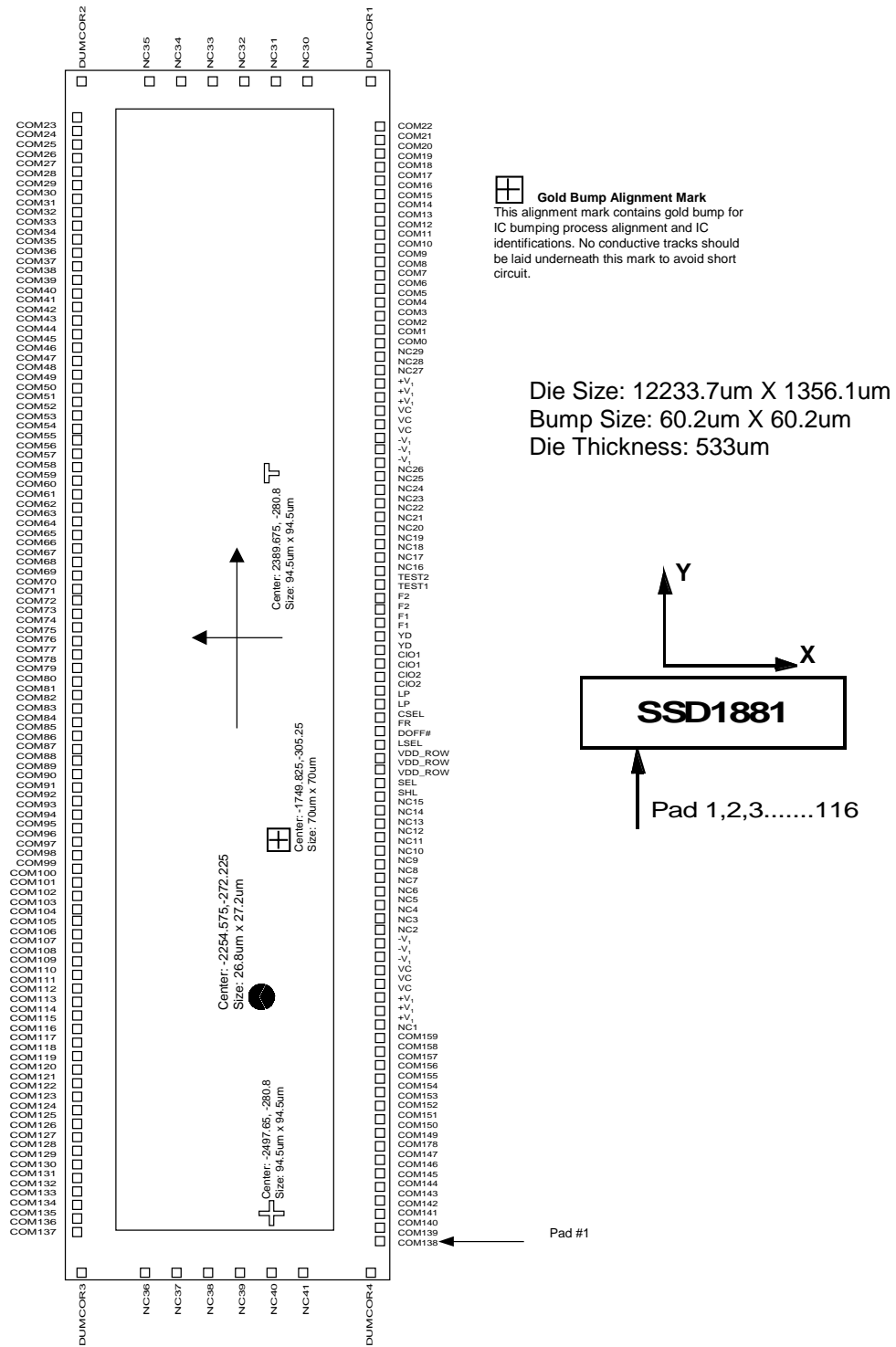

Figure 2 – SSD1881Z Die Pad Assignment

Table 2 - SSD1881Z Die Pad Coordinates

Pad#	Pin Name	X-pos	Y-pos	Pad#	Pin Name	X-pos	Y-pos	Pad#	Pin Name	X-pos	Y-pos
1	COM138	-5768.400	-507.000	61	CIO1	303.600	-507.000	121	NC34	5965.050	187.450
2	COM139	-5667.200	-507.000	62	YD	404.800	-507.000	122	NC35	5965.050	288.650
3	COM140	-5566.000	-507.000	63	YD	506.000	-507.000	123	DUMCOR2	5965.050	507.000
4	COM141	-5464.800	-507.000	64	F1	607.200	-507.000	124	COM23	5768.400	507.000
5	COM142	-5363.600	-507.000	65	F1	708.400	-507.000	125	COM24	5667.200	507.000
6	COM143	-5262.400	-507.000	66	F2	809.600	-507.000	126	COM25	5566.000	507.000
7	COM144	-5161.200	-507.000	67	F2	910.800	-507.000	127	COM26	5464.800	507.000
8	COM145	-5060.000	-507.000	68	TEST1	1012.000	-507.000	128	COM27	5363.600	507.000
9	COM146	-4958.800	-507.000	69	TEST2	1113.200	-507.000	129	COM28	5262.400	507.000
10	COM147	-4857.600	-507.000	70	NC16	1214.400	-507.000	130	COM29	5161.200	507.000
11	COM178	-4756.400	-507.000	71	NC17	1315.600	-507.000	131	COM30	5060.000	507.000
12	COM149	-4655.200	-507.000	72	NC18	1416.800	-507.000	132	COM31	4958.800	507.000
13	COM150	-4554.000	-507.000	73	NC19	1518.000	-507.000	133	COM32	4857.600	507.000
14	COM151	-4452.800	-507.000	74	NC20	1619.200	-507.000	134	COM33	4756.400	507.000
15	COM152	-4351.600	-507.000	75	NC21	1720.400	-507.000	135	COM34	4655.200	507.000
16	COM153	-4250.400	-507.000	76	NC22	1821.600	-507.000	136	COM35	4554.000	507.000
17	COM154	-4149.200	-507.000	77	NC23	1922.800	-507.000	137	COM36	4452.800	507.000
18	COM155	-4048.000	-507.000	78	NC24	2024.000	-507.000	138	COM37	4351.600	507.000
19	COM156	-3946.800	-507.000	79	NC25	2125.200	-507.000	139	COM38	4250.400	507.000
20	COM157	-3845.600	-507.000	80	NC26	2226.400	-507.000	140	COM39	4149.200	507.000
21	COM158	-3744.400	-507.000	81	-V1	2327.600	-507.000	141	COM40	4048.000	507.000
22	COM159	-3643.200	-507.000	82	-V1	2428.800	-507.000	142	COM41	3946.800	507.000
23	NC1	-3542.000	-507.000	83	-V1	2530.000	-507.000	143	COM42	3845.600	507.000
24	+V1	-3440.800	-507.000	84	VC	2631.200	-507.000	144	COM43	3744.400	507.000
25	+V1	-3339.600	-507.000	85	VC	2732.400	-507.000	145	COM44	3643.200	507.000
26	+V1	-3238.400	-507.000	86	VC	2833.600	-507.000	146	COM45	3542.000	507.000
27	VC	-3137.200	-507.000	87	+V1	2934.800	-507.000	147	COM46	3440.800	507.000
28	VC	-3036.000	-507.000	88	+V1	3036.000	-507.000	148	COM47	3339.600	507.000
29	VC	-2934.800	-507.000	89	-V1	3137.200	-507.000	149	COM48	3238.400	507.000
30	-V1	-2833.600	-507.000	90	NC27	3238.400	-507.000	150	COM49	3137.200	507.000
31	-V1	-2732.400	-507.000	91	NC28	3339.600	-507.000	151	COM50	3036.000	507.000
32	-V1	-2631.200	-507.000	92	NC29	3440.800	-507.000	152	COM51	2934.800	507.000
33	NC2	-2530.000	-507.000	93	COM0	3542.000	-507.000	153	COM52	2833.600	507.000
34	NC3	-2428.800	-507.000	94	COM1	3643.200	-507.000	154	COM53	2732.400	507.000
35	NC4	-2327.600	-507.000	95	COM2	3744.400	-507.000	155	COM54	2631.200	507.000
36	NC5	-2226.400	-507.000	96	COM3	3845.600	-507.000	156	COM55	2530.000	507.000
37	NC6	-2125.200	-507.000	97	COM4	3946.800	-507.000	157	COM56	2428.800	507.000
38	NC7	-2024.000	-507.000	98	COM5	4048.000	-507.000	158	COM57	2327.600	507.000
39	NC8	-1922.800	-507.000	99	COM6	4149.200	-507.000	159	COM58	2226.400	507.000
40	NC9	-1821.600	-507.000	100	COM7	4250.400	-507.000	160	COM59	2125.200	507.000
41	NC10	-1720.400	-507.000	101	COM8	4351.600	-507.000	161	COM60	2024.000	507.000
42	NC11	-1619.200	-507.000	102	COM9	4452.800	-507.000	162	COM61	1922.800	507.000
43	NC12	-1518.000	-507.000	103	COM10	4554.000	-507.000	163	COM62	1821.600	507.000
44	NC13	-1416.800	-507.000	104	COM11	4655.200	-507.000	164	COM63	1720.400	507.000
45	NC14	-1315.600	-507.000	105	COM12	4756.400	-507.000	165	COM64	1619.200	507.000
46	NC15	-1214.400	-507.000	106	COM13	4857.600	-507.000	166	COM65	1518.000	507.000
47	SHL	-1113.200	-507.000	107	COM14	4958.800	-507.000	167	COM66	1416.800	507.000
48	SEL	-1012.000	-507.000	108	COM15	5060.000	-507.000	168	COM67	1315.600	507.000
49	VDD_ROW	-910.800	-507.000	109	COM16	5161.200	-507.000	169	COM68	1214.400	507.000
50	VDD_ROW	-809.600	-507.000	110	COM17	5262.400	-507.000	170	COM69	1113.200	507.000
51	VDD_ROW	-708.400	-507.000	111	COM18	5363.600	-507.000	171	COM70	1012.000	507.000
52	LSEL	-607.200	-507.000	112	COM19	5464.800	-507.000	172	COM71	910.800	507.000
53	DOFF#	-506.000	-507.000	113	COM20	5566.000	-507.000	173	COM72	809.600	507.000
54	FR	-404.800	-507.000	114	COM21	5667.200	-507.000	174	COM73	708.400	507.000
55	CSEL	-303.600	-507.000	115	COM22	5768.400	-507.000	175	COM74	607.200	507.000
56	LP	-202.400	-507.000	116	DUMCOR1	5965.050	-507.000	176	COM75	506.000	507.000
57	LP	-101.200	-507.000	117	NC30	5965.050	-288.650	177	COM76	404.800	507.000
58	CIO2	0.000	-507.000	118	NC31	5965.050	-187.450	178	COM77	303.600	507.000
59	CIO2	101.200	-507.000	119	NC32	5965.050	-86.250	179	COM78	202.400	507.000
60	CIO1	202.400	-507.000	120	NC33	5965.050	86.250	180	COM79	101.200	507.000

Pad#	Pin Name	X-pos	Y-pos
181	COM80	0.000	507.000
182	COM81	-101.200	507.000
183	COM82	-202.400	507.000
184	COM83	-303.600	507.000
185	COM84	-404.800	507.000
186	COM85	-506.000	507.000
187	COM86	-607.200	507.000
188	COM87	-708.400	507.000
189	COM88	-809.600	507.000
190	COM89	-910.800	507.000
191	COM90	-1012.000	507.000
192	COM91	-1113.200	507.000
193	COM92	-1214.400	507.000
194	COM93	-1315.600	507.000
195	COM94	-1416.800	507.000
196	COM95	-1518.000	507.000
197	COM96	-1619.200	507.000
198	COM97	-1720.400	507.000
199	COM98	-1821.600	507.000
200	COM99	-1922.800	507.000
201	COM100	-2024.000	507.000
202	COM101	-2125.200	507.000
203	COM102	-2226.400	507.000
204	COM103	-2327.600	507.000
205	COM104	-2428.800	507.000
206	COM105	-2530.000	507.000
207	COM106	-2631.200	507.000
208	COM107	-2732.400	507.000
209	COM108	-2833.600	507.000
210	COM109	-2934.800	507.000
211	COM110	-3036.000	507.000
212	COM111	-3137.200	507.000
213	COM112	-3238.400	507.000
214	COM113	-3339.600	507.000
215	COM114	-3440.800	507.000
216	COM115	-3542.000	507.000
217	COM116	-3643.200	507.000
218	COM117	-3744.400	507.000
219	COM118	-3845.600	507.000
220	COM119	-3946.800	507.000
221	COM120	-4048.000	507.000
222	COM121	-4149.200	507.000
223	COM122	-4250.400	507.000
224	COM123	-4351.600	507.000
225	COM124	-4452.800	507.000
226	COM125	-4554.000	507.000
227	COM126	-4655.200	507.000
228	COM127	-4756.400	507.000
229	COM128	-4857.600	507.000
230	COM129	-4958.800	507.000
231	COM130	-5060.000	507.000
232	COM131	-5161.200	507.000
233	COM132	-5262.400	507.000
234	COM133	-5363.600	507.000
235	COM134	-5464.800	507.000
236	COM135	-5566.000	507.000
237	COM136	-5667.200	507.000
238	COM137	-5768.400	507.000
239	DUMCOR3	-5965.050	507.000
240	NC36	-5965.050	288.650

Pad#	Pin Name	X-pos	Y-pos
241	NC37	-5965.050	187.450
242	NC38	-5965.050	86.250
243	NC39	-5965.050	-86.250
244	NC40	-5965.050	-187.450
245	NC41	-5965.050	-288.650
246	DUMCOR4	-5965.050	-507.000

Table 3 – SSD1881TR Pin Assignment

Tab Pin#	Signal Name	Tab Pin#	Signal Name	Tab Pin#	Signal Name	Tab Pin#	Signal Name
1	NC	61	COM34	121	COM94	181	COM154
2	+V ₁	62	COM35	122	COM95	182	COM155
3	VC	63	COM36	123	COM96	183	COM156
4	-V ₁	64	COM37	124	COM97	184	COM157
5	SHL	65	COM38	125	COM98	185	COM158
6	SEL	66	COM39	126	COM99	186	COM159
7	VDD_ROW	67	COM40	127	COM100	187	NC
8	LSEL	68	COM41	128	COM101	188	NC
9	DOFF#	69	COM42	129	COM102	189	NC
10	FR	70	COM43	130	COM103		
11	CSEL	71	COM44	131	COM104		
12	LP	72	COM45	132	COM105		
13	CIO2	73	COM46	133	COM106		
14	CIO1	74	COM47	134	COM107		
15	YD	75	COM48	135	COM108		
16	DUMMY	76	COM49	136	COM109		
17	F1	77	COM50	137	COM110		
18	F2	78	COM51	138	COM111		
19	TEST1	79	COM52	139	COM112		
20	-V ₁	80	COM53	140	COM113		
21	VC	81	COM54	141	COM114		
22	+V ₁	82	COM55	142	COM115		
23	NC	83	COM56	143	COM116		
24	NC	84	COM57	144	COM117		
25	NC	85	COM58	145	COM118		
26	NC	86	COM59	146	COM119		
27	COM0	87	COM60	147	COM120		
28	COM1	88	COM61	148	COM121		
29	COM2	89	COM62	149	COM122		
30	COM3	90	COM63	150	COM123		
31	COM4	91	COM64	151	COM124		
32	COM5	92	COM65	152	COM125		
33	COM6	93	COM66	153	COM126		
34	COM7	94	COM67	154	COM127		
35	COM8	95	COM68	155	COM128		
36	COM9	96	COM69	156	COM129		
37	COM10	97	COM70	157	COM130		
38	COM11	98	COM71	158	COM131		
39	COM12	99	COM72	159	COM132		
40	COM13	100	COM73	160	COM133		
41	COM14	101	COM74	161	COM134		
42	COM15	102	COM75	162	COM135		
43	COM16	103	COM76	163	COM136		
44	COM17	104	COM77	164	COM137		
45	COM18	105	COM78	165	COM138		
46	COM19	106	COM79	166	COM139		
47	COM20	107	COM80	167	COM140		
48	COM21	108	COM81	168	COM141		
49	COM22	109	COM82	169	COM142		
50	COM23	110	COM83	170	COM143		
51	COM24	111	COM84	171	COM144		
52	COM25	112	COM85	172	COM145		
53	COM26	113	COM86	173	COM146		
54	COM27	114	COM87	174	COM147		
55	COM28	115	COM88	175	COM148		
56	COM29	116	COM89	176	COM149		
57	COM30	117	COM90	177	COM150		
58	COM31	118	COM91	178	COM151		
59	COM32	119	COM92	179	COM152		
60	COM33	120	COM93	180	COM153		

7. SSD1881T1R1 TAB PIN ASSIGNMENT

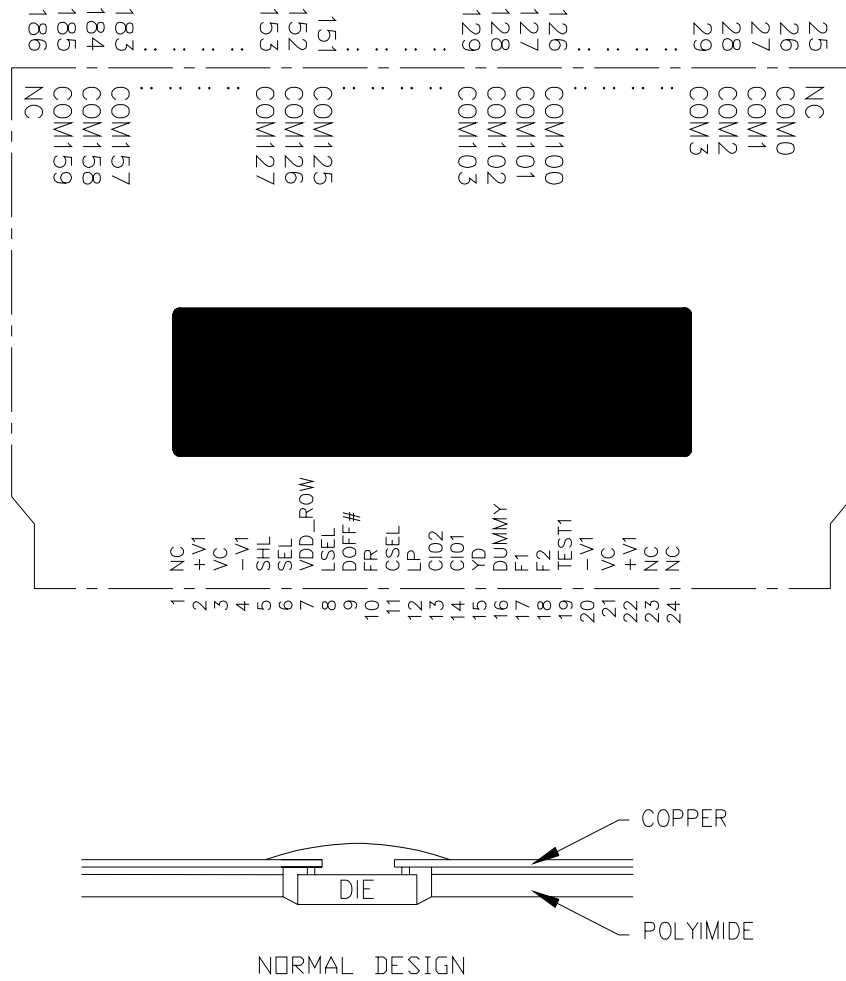

Figure 4 – SSD1881T1R1 Pin Assignment (Copper View, Normal TAB Design)

Table 4 – SSD1881T1R1 Pin Assignment

Tab Pin#	Signal Name
1	NC
2	+V ₁
3	VC
4	-V ₁
5	SHL
6	SEL
7	VDD_ROW
8	LSEL
9	DOFF#
10	FR
11	CSEL
12	LP
13	CIO2
14	CIO1
15	YD
16	DUMMY
17	F1
18	F2
19	TEST1
20	-V ₁
21	VC
22	+V ₁
23	NC
24	NC
25	NC
26	COM0
27	COM1
28	COM2
29	COM3
30	COM4
31	COM5
32	COM6
33	COM7
34	COM8
35	COM9
36	COM10
37	COM11
38	COM12
39	COM13
40	COM14
41	COM15
42	COM16
43	COM17
44	COM18
45	COM19
46	COM20
47	COM21
48	COM22
49	COM23
50	COM24
51	COM25
52	COM26
53	COM27
54	COM28
55	COM29
56	COM30
57	COM31
58	COM32
59	COM33
60	COM34

Tab Pin#	Signal Name
61	COM35
62	COM36
63	COM37
64	COM38
65	COM39
66	COM40
67	COM41
68	COM42
69	COM43
70	COM44
71	COM45
72	COM46
73	COM47
74	COM48
75	COM49
76	COM50
77	COM51
78	COM52
79	COM53
80	COM54
81	COM55
82	COM56
83	COM57
84	COM58
85	COM59
86	COM60
87	COM61
88	COM62
89	COM63
90	COM64
91	COM65
92	COM66
93	COM67
94	COM68
95	COM69
96	COM70
97	COM71
98	COM72
99	COM73
100	COM74
101	COM75
102	COM76
103	COM77
104	COM78
105	COM79
106	COM80
107	COM81
108	COM82
109	COM83
110	COM84
111	COM85
112	COM86
113	COM87
114	COM88
115	COM89
116	COM90
117	COM91
118	COM92
119	COM93
120	COM94

Tab Pin#	Signal Name
121	COM95
122	COM96
123	COM97
124	COM98
125	COM99
126	COM100
127	COM101
128	COM102
129	COM103
130	COM104
131	COM105
132	COM106
133	COM107
134	COM108
135	COM109
136	COM110
137	COM111
138	COM112
139	COM113
140	COM114
141	COM115
142	COM116
143	COM117
144	COM118
145	COM119
146	COM120
147	COM121
148	COM122
149	COM123
150	COM124
151	COM125
152	COM126
153	COM127
154	COM128
155	COM129
156	COM130
157	COM131
158	COM132
159	COM133
160	COM134
161	COM135
162	COM136
163	COM137
164	COM138
165	COM139
166	COM140
167	COM141
168	COM142
169	COM143
170	COM144
171	COM145
172	COM146
173	COM147
174	COM148
175	COM149
176	COM150
177	COM151
178	COM152
179	COM153
180	COM154

Tab Pin#	Signal Name
181	COM155
182	COM156
183	COM157
184	COM158
185	COM159
186	NC

8. SSD1881T2R TAB PIN ASSIGNMENT

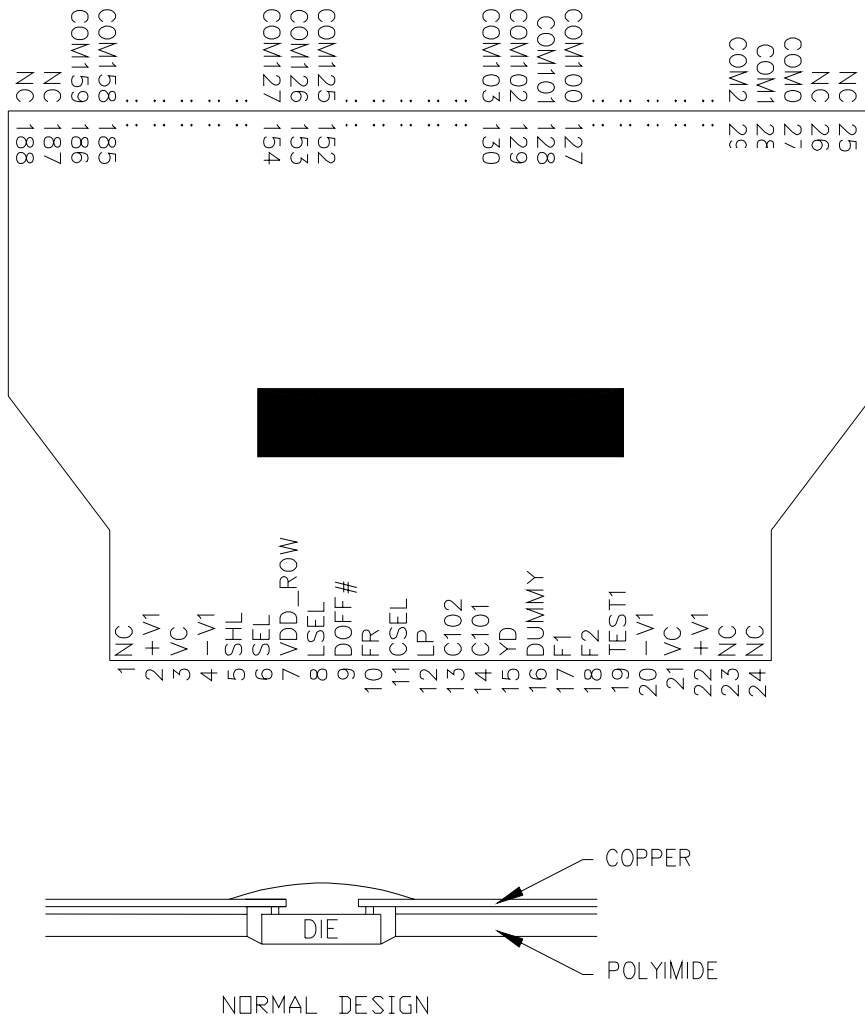

Figure 5 – SSD1881T2R Pin Assignment (Copper View, Normal TAB Design)

Table 5 – SSD1881T2R Pin Assignment

PIN#	NAME	PIN#	NAME	PIN#	NAME	PIN#	NAME
1	NC	51	COM24	101	COM74	151	COM124
2	+V1	52	COM25	102	COM75	152	COM125
3	VC	53	COM26	103	COM76	153	COM126
4	-V1	54	COM27	104	COM77	154	COM127
5	SHL	55	COM28	105	COM78	155	COM128
6	SEL	56	COM29	106	COM79	156	COM129
7	VDD_ROW	57	COM30	107	COM80	157	COM130
8	LSEL	58	COM31	108	COM81	158	COM131
9	DOFF#	59	COM32	109	COM82	159	COM132
10	FR	60	COM33	110	COM83	160	COM133
11	CSEL	61	COM34	111	COM84	161	COM134
12	LP	62	COM35	112	COM85	162	COM135
13	C102	63	COM36	113	COM86	163	COM136
14	C101	64	COM37	114	COM87	164	COM137
15	YD	65	COM38	115	COM88	165	COM138
16	DUMMY	66	COM39	116	COM89	166	COM139
17	F1	67	COM40	117	COM90	167	COM140
18	F2	68	COM41	118	COM91	168	COM141
19	TEST1	69	COM42	119	COM92	169	COM142
20	-V1	70	COM43	120	COM93	170	COM143
21	VC	71	COM44	121	COM94	171	COM144
22	+V1	72	COM45	122	COM95	172	COM145
23	NC	73	COM46	123	COM96	173	COM146
24	NC	74	COM47	124	COM97	174	COM147
25	NC	75	COM48	125	COM98	175	COM148
26	NC	76	COM49	126	COM99	176	COM149
27	COM0	77	COM50	127	COM100	177	COM150
28	COM1	78	COM51	128	COM101	178	COM151
29	COM2	79	COM52	129	COM102	179	COM152
30	COM3	80	COM53	130	COM103	180	COM153
31	COM4	81	COM54	131	COM104	181	COM154
32	COM5	82	COM55	132	COM105	182	COM155
33	COM6	83	COM56	133	COM106	183	COM156
34	COM7	84	COM57	134	COM107	184	COM157
35	COM8	85	COM58	135	COM108	185	COM158
36	COM9	86	COM59	136	COM109	186	COM159
37	COM10	87	COM60	137	COM110	187	NC
38	COM11	88	COM61	138	COM111	188	NC
39	COM12	89	COM62	139	COM112		
40	COM13	90	COM63	140	COM113		
41	COM14	91	COM64	141	COM114		
42	COM15	92	COM65	142	COM115		
43	COM16	93	COM66	143	COM116		
44	COM17	94	COM67	144	COM117		
45	COM18	95	COM68	145	COM118		
46	COM19	96	COM69	146	COM119		
47	COM20	97	COM70	147	COM120		
48	COM21	98	COM71	148	COM121		
49	COM22	99	COM72	149	COM122		
50	COM23	100	COM73	150	COM123		

9. PIN DESCRIPTION

VDD_ROW, +V1, VC, -V1 (Power Pin)

VDD_ROW is a power pin to supply power to the logic system. The voltage range is 2.7V to 5.5V with respect to the -V1 pin. +V1, VC and -V1 are power supply pins to the LCD system. Their relationship is $+V1 \geq VC \geq VDD_ROW \geq -V1$.

YD (Input Pin)

This input pin is used as a signal to start a frame and to reset the column address for writing. (Refer to Note 1)

LP (Input Pin)

This is an input pin and is used as a display data latch clock. The display data is latched at the falling edge of LP. (Refer to Note 1)

FR (Input Pin)

This is an input pin and is used to change the LCD driving waveform polarity. If a power chip SSD1730 is used, the output FR from the power chip should be connected to the FR pin of the row driver. (Refer to Note 1)

F1, F2 (Input Pin)

These are input pins and are used as driver pattern select signals. These two signals are generated by a column driver. If a display system is formed by the column driver SSD1870 and the row driver SSD1881, outputs F10 and F20 from the column driver should be connected to F1 and F2 of the row driver respectively. (Refer to Note 1)

DOFF# (Input Pin)

This is an input pin and is used to control the LC display. When it is set at "L" level, all common outputs are forced to V_C level and the LC display will be forced to blank, however, the contents of the latches are maintained. In the normal display operation, it is set to "H" level. (Refer to Note 1)

SEL (Input Pin)

SSD1881 can be configured as 140 common outputs or 160 common outputs which is controlled by this input pin SEL. When SEL is set at "L" level, 160 outputs are chosen and COM0 to COM159 will be used. When SEL is set at "H" level, 140 outputs are chosen and COM8 to COM147 will be used.

CIO1, CIO2 (I/O Pin)

These are I/O pins and they can be configured as an input or an output depending on the signal of SHL. When SHL is set at "L" level, CIO1 is input and CIO2 is output. When SHL is set at "H" level, CIO1 is output and CIO2 is input. The output transition occurs on the falling edge of LP. (Refer to Note 1)

SHL (Input Pin)

This is an input pin and is used to select the output shift direction and to configure CIO1 and CIO2. Below table shows the relationship between SEL, SHL, CIO1, CIO2 and the output shift direction.

SEL = L (160 common outputs)			
SHL	Output Shift Direction	CIO	CIO2
L	COM0 -> COM159	Input	Output
H	COM159 -> COM0	Output	Input
SEL = L (140 common outputs)			
SHL	Output Shift Direction	CIO	CIO2
L	COM8 -> COM147	Input	Output
H	COM147 -> COM8	Output	Input

Table 6 - Relationship between SEL, SHL, CIO2 and CIO2

LSEL (Input Pin)

This is an input pin and is used to select 1P Normal Operation or 1/2P Operation. That can cope with different LCD having different response time.

When LSEL is set at "L" level, 1P Normal Operation is selected. when LSEL is set at "H" level, 1/2P Operation is selected.

CSEL (Input Pin)

This is a chip select signal input. When only one common driver is used, CSEL should be set at "L" level. When multiple common drivers are used, CSEL of the leading chip must be tied to "L" level and that of other chips must be tied to "H" level.

TEST1 (Input Pin)

This is a reserved pin and it must be set at "L" level in the normal operation.

TEST2 (Input Pin, only exists on gold-bumped die)

This is a reserved pin and it must be set at "L" level in the normal operation.

COM0-COM159 (Output Pin)

These are output pins and provide common driving signals to the LCD panel. Output transition occurs at the falling edge of LP.

NCx and DUMCORx (Dummy Pin)

These are NC pins and dummy pins. They must be left open & unconnected. Don't group the NC pins or dummy pins together.

Note 1: If an MLA LCD system is formed by SSD1881 row driver, SSD1870 column driver and SSD1730 power chip, 1nF capacitors are necessary for the capacitor coupling purpose. Refer to the Application example for circuit connection.

10. FUNCTIONAL BLOCK DESCRIPTIONS

Controller and Data Register

Based on the input signal of FR, F1, F2 and LP, this Controller will generate signals to control the Data Register. Then, the Data Register will latch the data to the Common Cell Level Shifter according to the signals from the Controller and the data from the Shift Register. The data is latched to the Common Cell Level Shifter at the falling edge of LP.

Bi-directional Shift Register

This Shift Register will shift the input signals YD and CIO input according to the setting of SHL, SEL, LSEL and CSEL. When SHL is set at "L" level, CIO1 is input and CIO2 is output. When SHL is set at "H" level, CIO1 is output and CIO2 is input. The output transition occurs on the falling edge of LP.

Common Cell Level Shifter

This is a level interface circuit which is used to convert the signal voltage level from a logic system level to the LCD driver system voltage level. When DOFF# is at "L" level, all common output voltage will be at VC level. When DOFF# is at "H" level, the common output voltage will be changed according to the status of input signals of FR, F1 and F2.

Table 7 shows the relationship among the common output voltage and the input signals FR, F1 and F2. Table 8 shows the relationship between line number and Common.

When DOFF# = H and FR = L					When DOFF# = H and FR = H				
F1	1	0	1	0	F1	1	0	1	0
F2	1	1	0	0	F2	1	1	0	0
line r	+V1	+V1	-V1	+V1	line r	-V1	-V1	+V1	-V1
line (r + 1)	-V1	+V1	+V1	+V1	line (r + 1)	+V1	-V1	-V1	-V1
line (r + 2)	+V1	-V1	+V1	+V1	line (r + 2)	-V1	+V1	-V1	-V1
line (r + 3)	+V1	+V1	+V1	-V1	line (r + 3)	-V1	-V1	-V1	+V1

Table 7 – Relationship among COM voltage, F1, F2 and FR

Line number	Formula	Common
r	Multiples of 4	0, 4, 8, 12, ... , 148, 152, 156
r + 1	1 + multiples of 4	1, 5, 9, 13, ... , 149, 153, 157
r + 2	2 + multiples of 4	2, 6, 10, 14, ... , 150, 154, 158
r + 3	3 + multiples of 4	3, 7, 11, 15, ... , 151, 155, 159

Table 8 - Relationship between line number and Common.

Timing Diagram For 1/160 duty and 1P operation (DOFF# = H and FR=L)

This diagram is for reference only. Below diagram is at the conditions of SHL = L, SEL = L, LSEL = L, CSEL = L

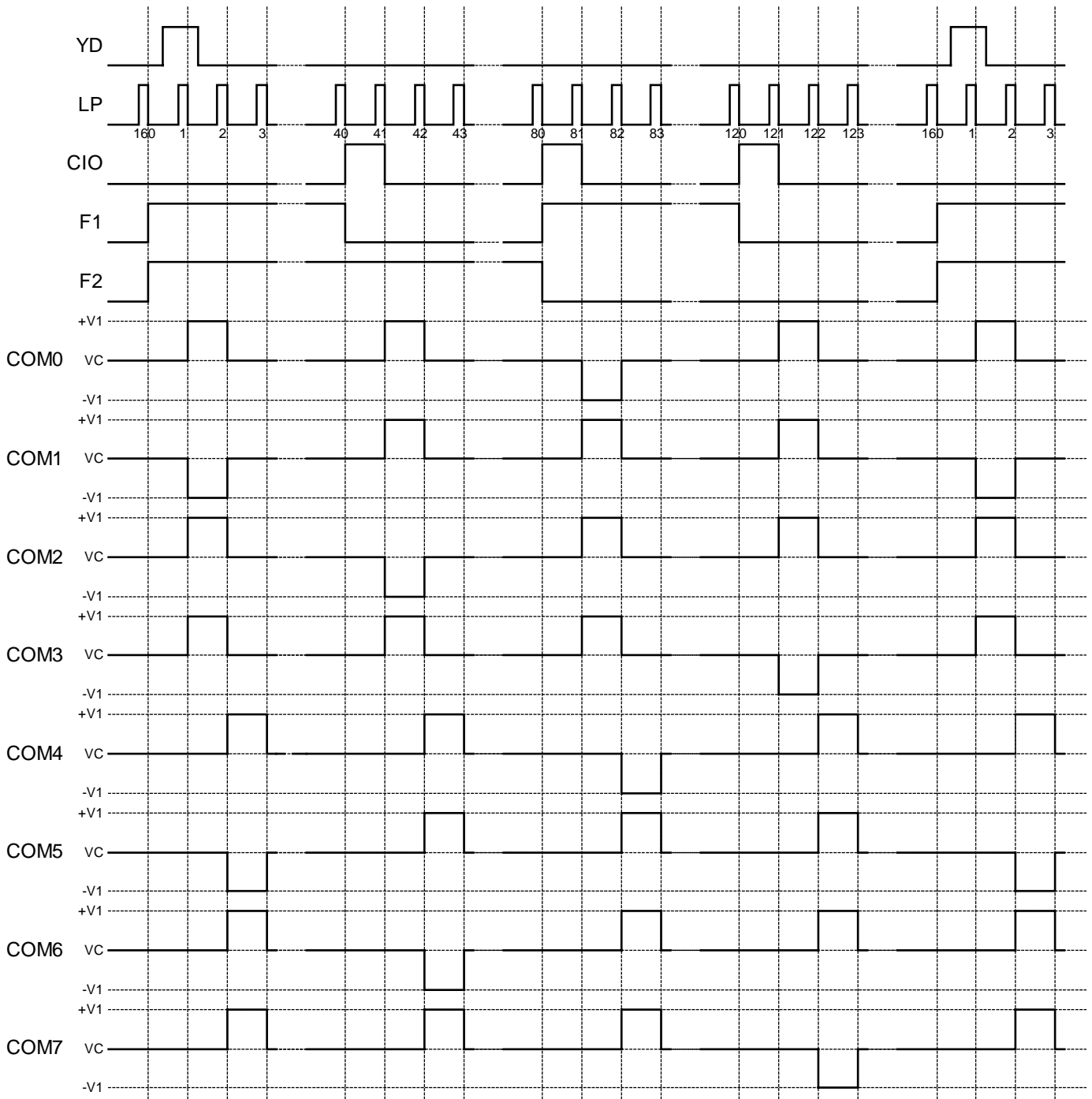

Figure 6 – Timing diagram for 1/160 duty and 1P operation (DOFF# = H and FR = L)

Timing Diagram For 1/160 duty and 1P operation (DOFF# = H and FR=H)

This diagram is for reference only., Below diagram is at the conditions of SHL = L, SEL = L, LSEL = L, CSEL = L

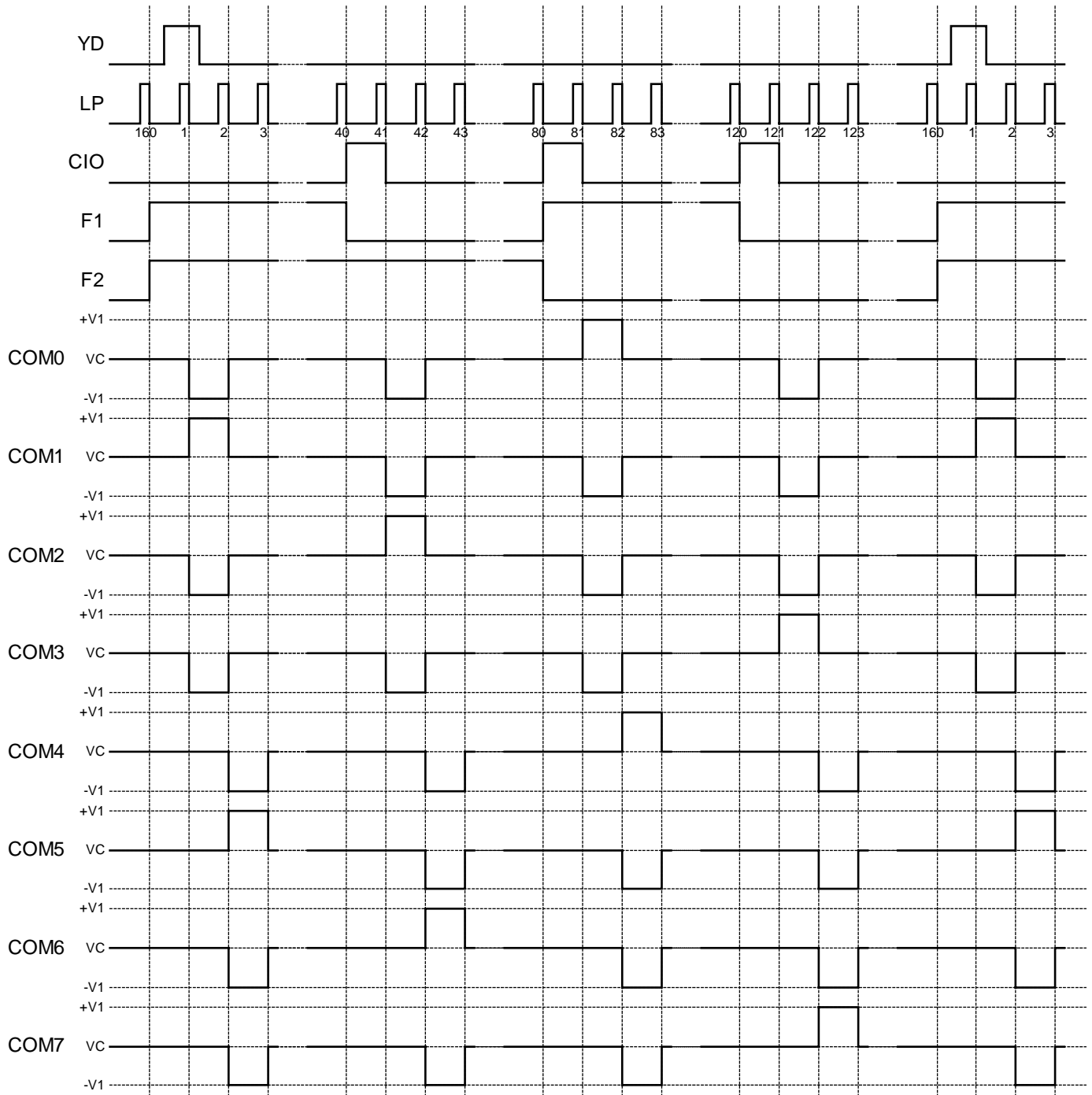

Figure 7 – Timing diagram for 1/160 duty and 1P operation (DOFF# = H and FR = H)

Timing Diagram For 1/160 duty and 1/2P operation (DOFF# = H and FR = L)

This diagram is for reference only. Below diagram is at the conditions of SHL = L, SEL = L, LSEL = H, CSEL = L

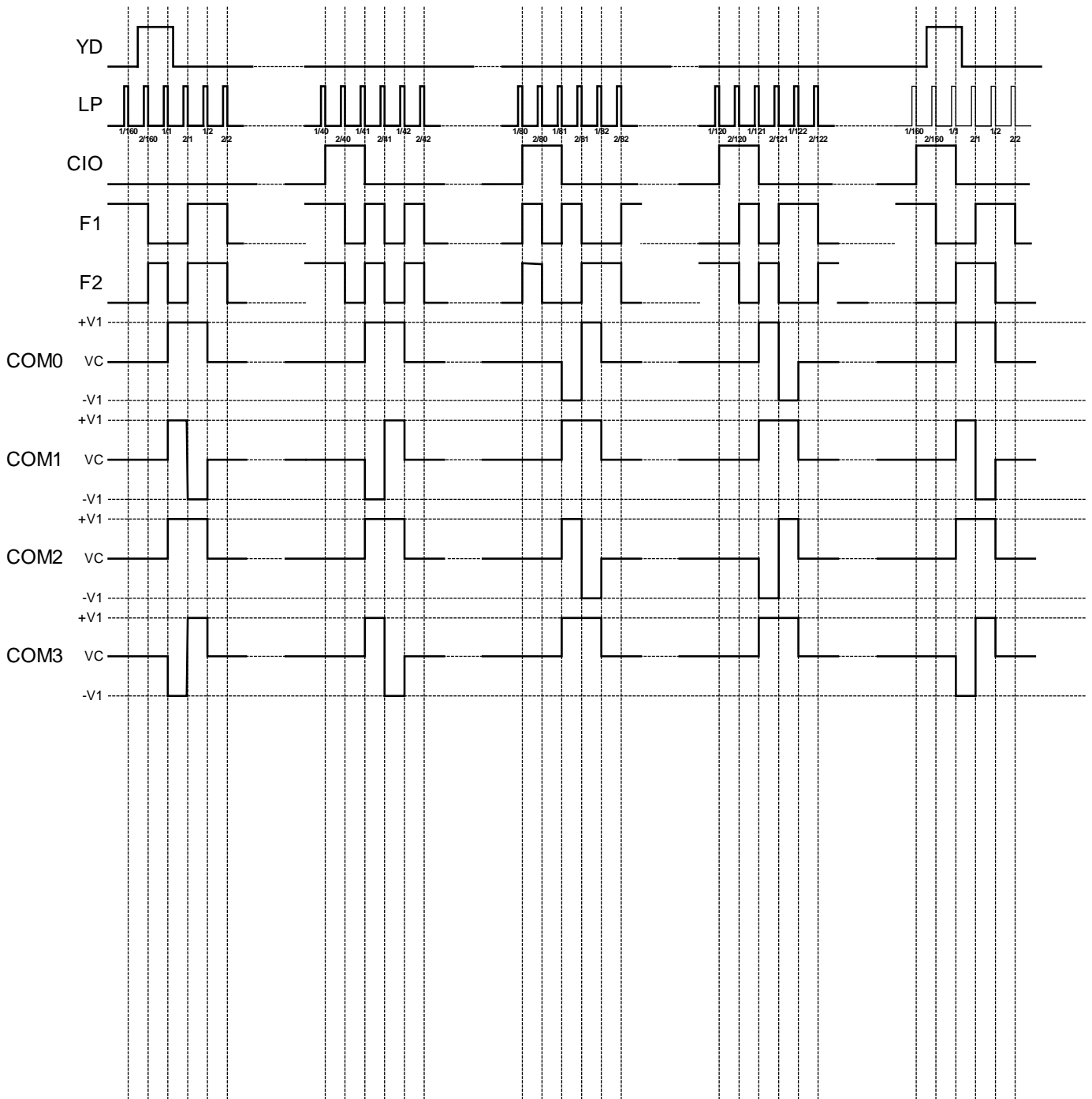

Figure 8 – Timing diagram for 1/160 duty and 1/2P operation (DOFF# = H and FR = L)

Timing Diagram For 1/160 duty and 1/2P operation (DOFF# = H and FR = H)

This diagram is for reference only. Below diagram is at the conditions of SHL = L, SEL = L, LSEL = H, CSEL = L

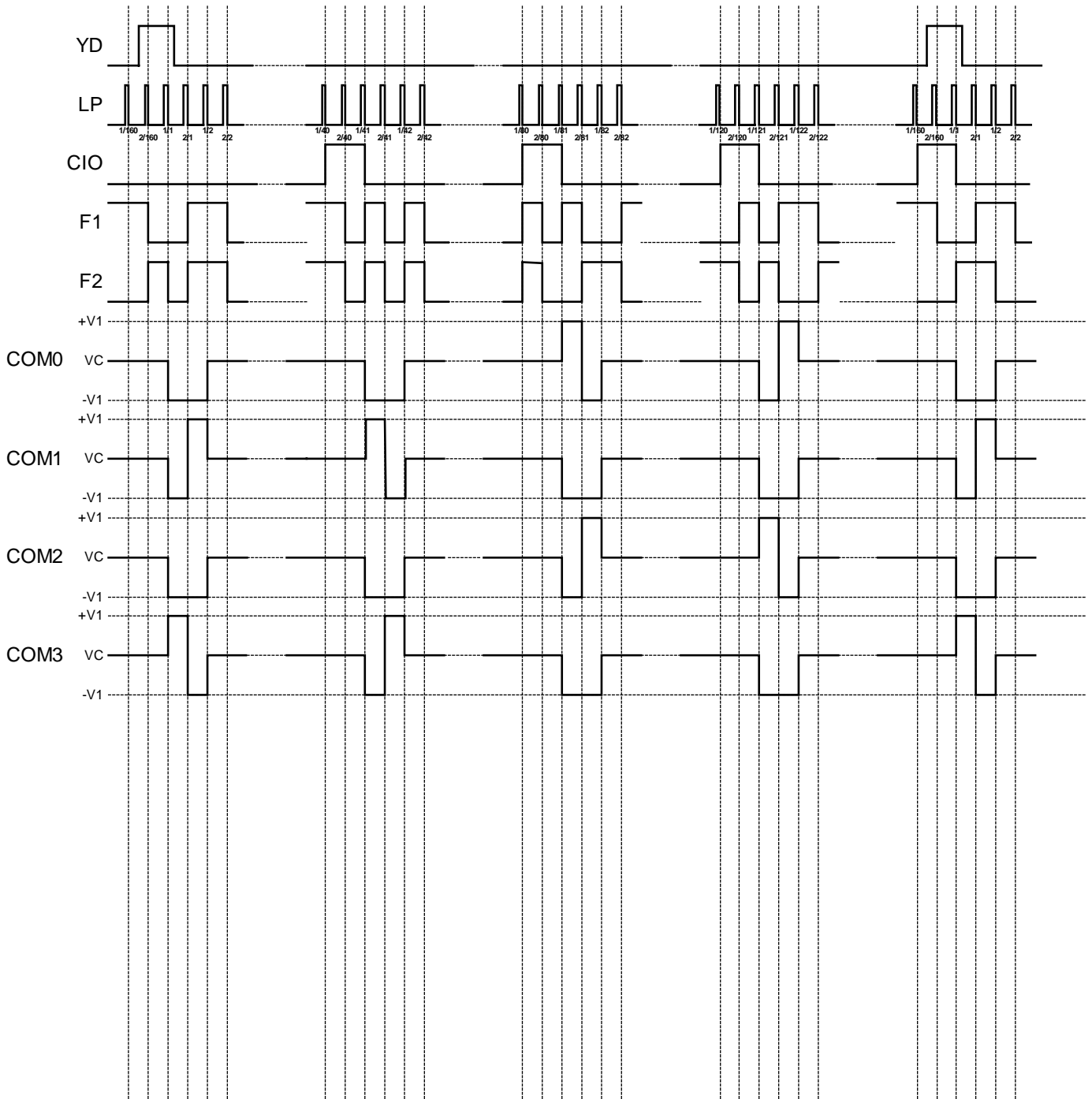

Figure 9 – Timing diagram for 1/160 duty and 1/2P operation (DOFF# = H and FR = H)

11. MAXIMUM RATINGS

Symbol	Parameter	Value	Unit
VDD_ROW	Power Voltage	-0.3 to +7.0	V
+V1		-0.3 to 33	V
V _{IN}	Input Voltage	-V1 - 0.3 to +V1 + 0.3	V
V _o	Output Voltage	-V1 - 0.3 to +V1 + 0.3	V
I	Output current at CIO	20	mA
T _A	Operating temperature	-30 to +85	°C
T _{stg}	Storage temperature	-65 to +150	°C

Table 9 – Maximum ratings for DC characteristics

Maximum ratings are those values beyond which damage to the device may occur. Functional operation should be restricted to the limits shown in the DC characteristics section and the relationship between +V1, VC and -V1 must be $+V1 \geq VC \geq VDD_ROW \geq -V1$. All voltages are referenced to -V1 = 0V.

This device contains circuitry to protect the inputs against damage due to high static voltages of electric fields; however, it is advised that normal precautions to be taken to avoid application of any voltage higher than maximum rated voltages to this high impedance circuit. All dummy pins and NC pins must be left open & unconnected. Don't group the NC pins together. The device may be light sensitive. Caution should be taken to avoid exposure of this device to any light source during normal operation. This device is not radiation protected.

12. DC CHARACTERISTICS

-V1 = 0.0V, VDD_ROW = 5.0V, T_A = 25°C

Symbol	Parameter	Test Condition	Min	Typ	Max	Unit
VDD_ROW	Power supply voltage for logic system		2.7	5.0	5.5	V
+V1 VC	Power supply voltage for LCD	-V1 = 0.0, VDD_ROW = 5.0V	14.0 --	-- +V1/2	30.0 --	V V
I _{DP1}	Current drain from Pin VDD_ROW	VDD_ROW=5.0V, V _{IN} =VDD_ROW, V _{IL} =-V1, freq of LP=16.8kHz and freq of FR=70Hz, no loading	--	6	25	μA
I _{ΔT2}	Current drain from Pin +V1	+V1=30V, V _C =+V1/2, -V1=0.0V, VDD_ROW=5.0V, V _{IN} =VDD_ROW, V _{IL} =-V1, freq of LP=16.8kHz and freq of FR=70Hz, no loading	--	16	30	μA
I _{SB}	Static current drain from Pin VDD_ROW	+V1 =14.0V to 30.0V, V _{IN} = VDD_ROW, V _{IL} = -V1	--	0.25	2	μA
V _{IH} V _{IL}	Input High voltage at pins: CIO1, CIO2, SHL, SEL, LSEL, CSEL, FR, YD, LP, F1, F2 & DOFF# Input Low voltage at pins: CIO1, CIO2, SHL, SEL, LSEL, CSEL, FR, YD, LP, F1, F2, TEST1 & DOFF#	VDD_ROW = 2.7V to 5.5V	0.8*VDD_ROW --	-- --	-- 0.2*VDD_ROW	V V
V _{OH}	Output High voltage at pins: CIO1 & CIO2	VDD_ROW = 2.7V to 5.5V, I _{OH} = -0.3mA	VDD_ROW-0.4	--	--	V
V _{OL}	Output Low voltage at pins: CIO1 & CIO2	VDD_ROW = 2.7V to 5.5V, I _{OL} = 0.3mA	--	--	0.4	V
I _{L1}	Input leakage current at pins: SHL, SEL, LSEL, CSEL, FR, YD, LP, F1, F2, TEST1 & DOFF#		--	--	2	μA
I _{L2}	I/O leakage current at pins: CIO1 & CIO2		--	--	5	μA
Rout	Output resistance of pins: COM0 – COM159	-V1 = 0.0V, +V1 =30.0V, ΔV =0.5V	--	--	1000	Ω

Table 10 – Electrical characteristics

13.AC CHARACTERISTICS

Input Timing Characteristics

$-V_1 = 0.0V, VDD_ROW = 5.0V, T_A = 25^\circ C$

Symbol	Parameter	Min	Typ	Max	Unit
t_{LPcyc}	LP period	500	-	-	ns
t_{LPHi}	LP pulse width (High level)	55	-	-	ns
t_{LPlo}	LP pulse width (Low level)	330	-	-	ns
t_{YDs}	YD, CIO setup time	100	-	-	ns
t_{YDh}	YD, CIO hold time	40	-	-	ns
t_{YDset}	YD --> LP allowable time	80	-	-	ns
t_{F12s}	F1, F2 setup time	100	-	-	ns
t_{F12h}	F1, F2 hold time	40	-	-	ns
t_{FRs}	FR setup time	100	-	-	ns
t_{FRh}	FR hold time	40	-	-	ns
t_r	Input signal rise time	-	-	50	ns
t_f	Input signal fall time	-	-	50	ns

Table 11 - Input timing characteristics

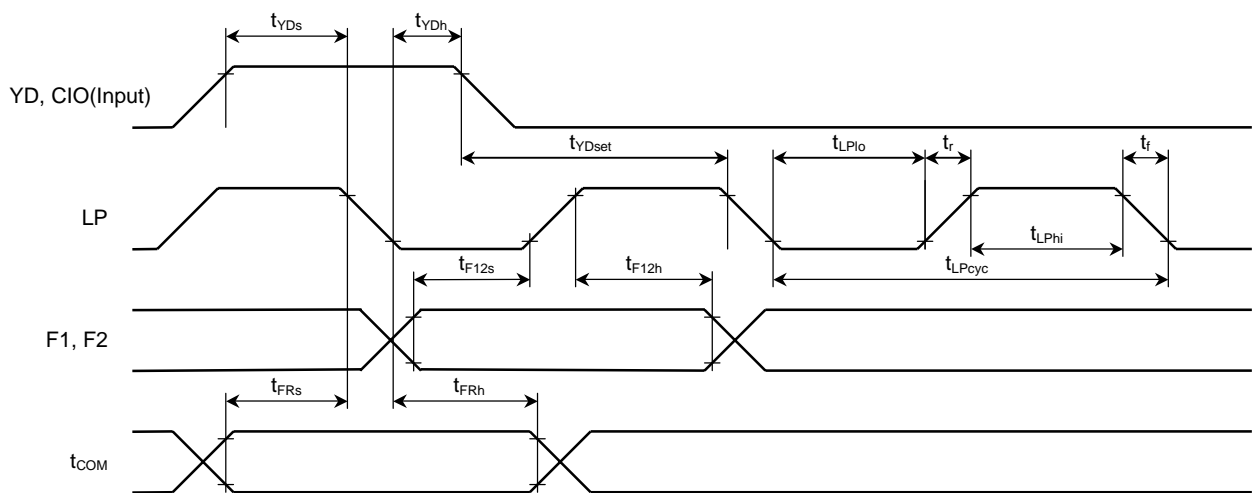

Figure 10 – Input timing characteristics

Output Timing Characteristics

$-V_1 = 0.0V$, $VDD_ROW = 5.0V$, $T_A = 25^\circ C$

Symbol	Parameter	Min	Typ	Max	Unit
t_{COMd1}	Delay time from LP to COM	-	-	300	ns
t_{COMd2}	Delay time from DOFF# to COM	-	-	350	ns
t_{CIOd}	Delay time from LP to CIO output	-	-	700	ns

Table 12 – Output timing characteristics

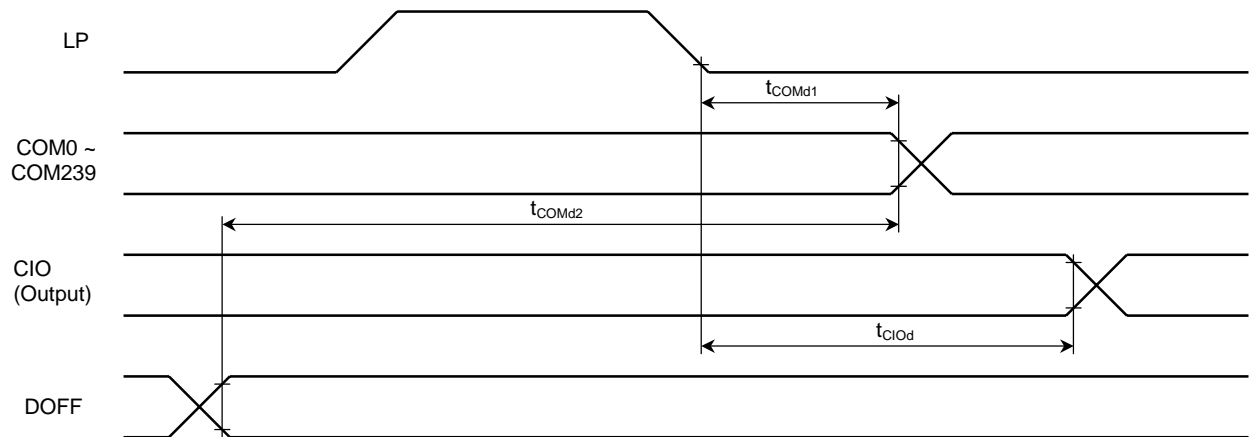

Figure 11 – Output timing characteristics

14. APPLICATION EXAMPLE – 160 X 160 LCD SYSTEM

Below figure shows an example of a 160 x 160 LCD system using the Power Chip SSD1730, the Row Driver SSD1881 and the Column Driver SSD1870. In order to operate the system, power source is applied to V_{DD} & V_{SS} and a controller is used to issue signals to DOFF#, YD, LP, XSCL and data bus D0-D7.

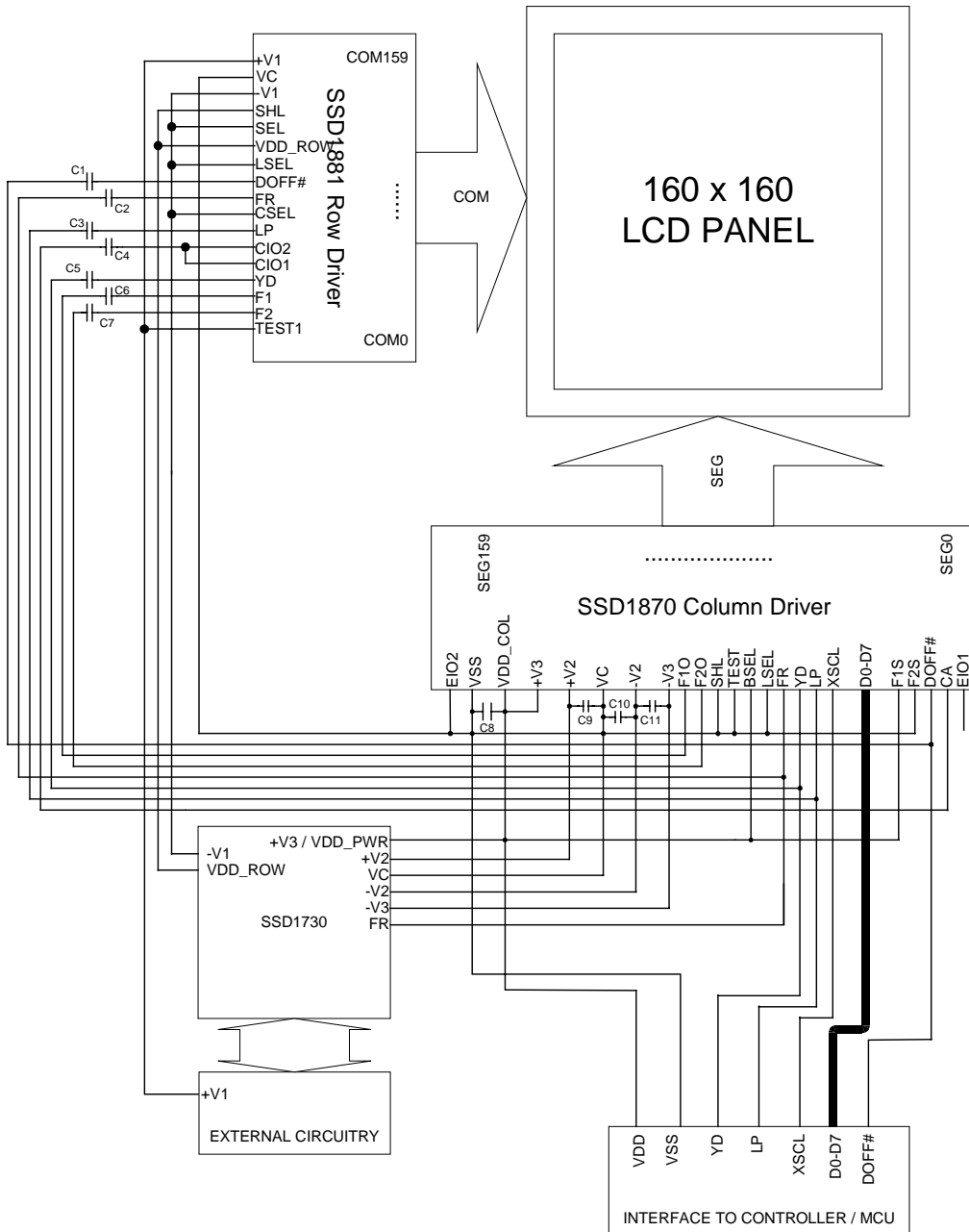

Figure 12 – 160 x 160 LCD system

Note 2 : 1nF capacitor is necessary for the capacitor coupling purpose.

Note 3 : Refer to the application circuit in the SSD1730 power chip specification.

15. PACKAGE DIMENSION

SSD1881TR TAB Package Dimension – 1

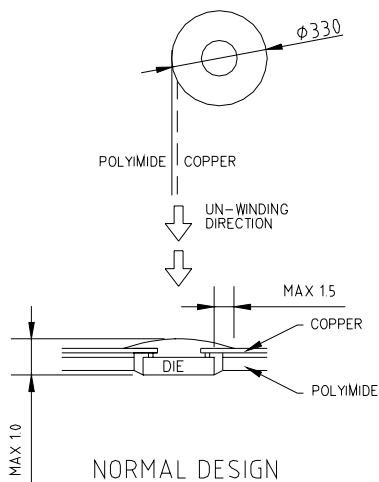
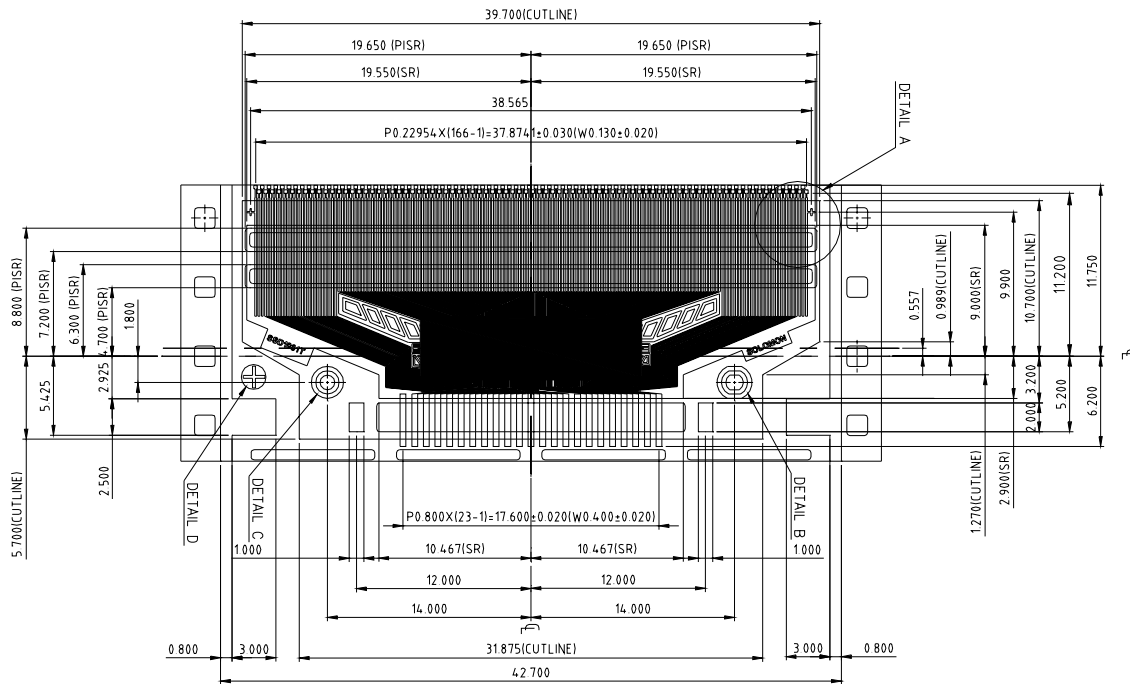

- NOTE:
- GENERAL TOLERANCE: $\pm 0.05\text{MM}$
 - MATERIAL
 - PI: UPILEX $75 \pm 6\mu\text{M}$
 - ADHESIVE: $12 \pm 2\mu\text{M}$
 - CU: $25\mu\text{M}$
 - SR: $26 \pm 14\mu\text{M}$
 - FLEX COATING: FS-100L
 - SN PLATING: PURE SN $0.20 \pm 0.05\mu\text{M}$
 - TAPSITE: 4 SPH, 19MM

SSD1881TR TAB Package Dimension – 2

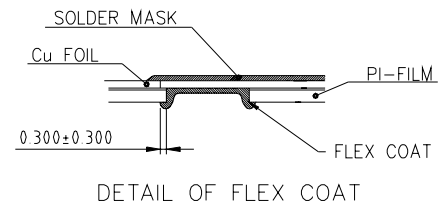
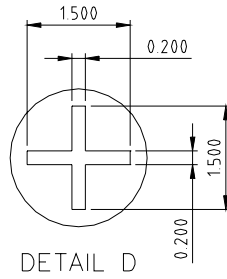
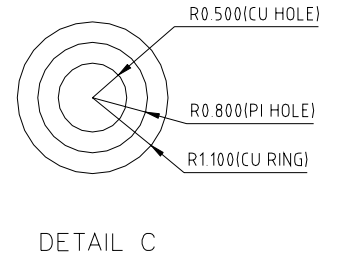
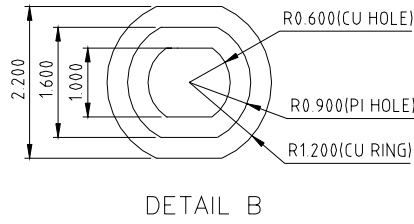
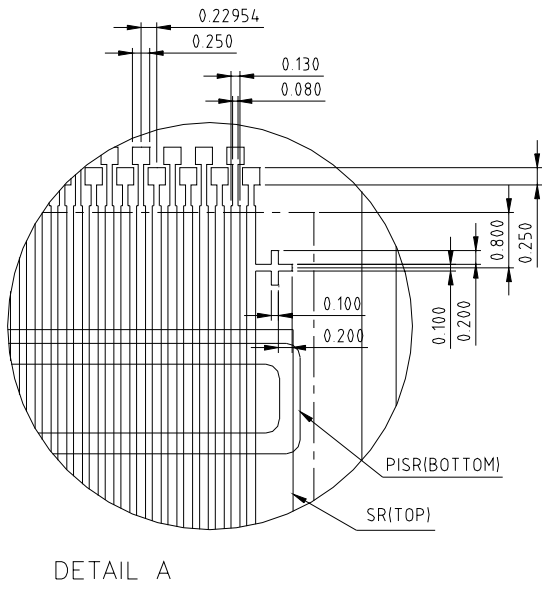

SSD1881T1R1 TAB PACKAGE DIMENSION – 1

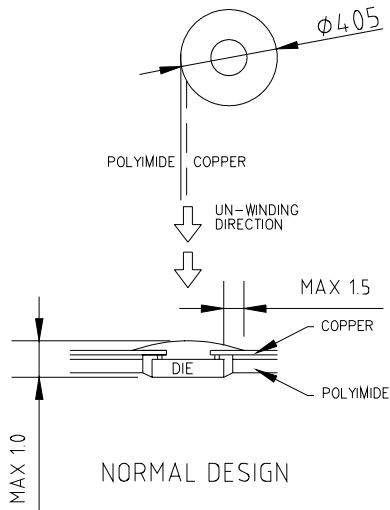
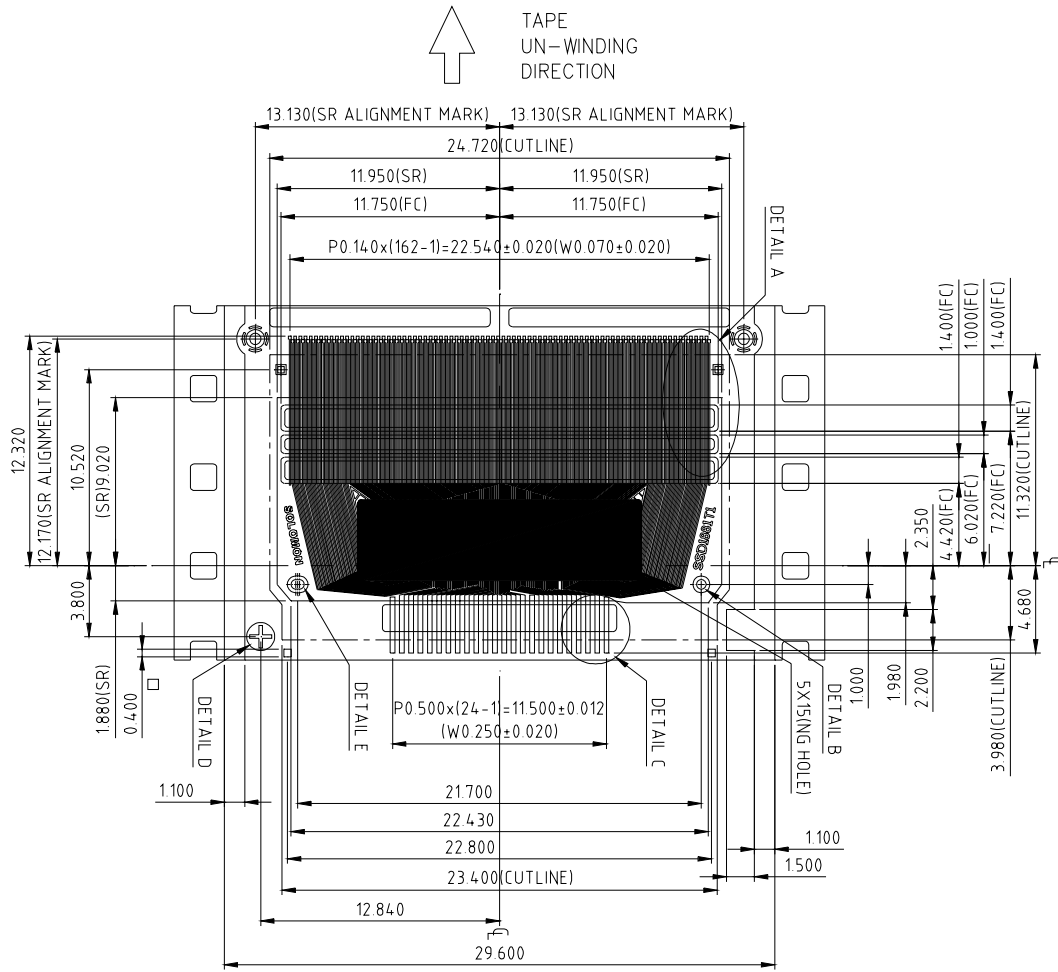

NOTE:

1. GENERAL TOLERANCE: $\pm 0.05\text{MM}$
2. MATERIAL
 - PI: UPILEX $75 \pm 6\mu\text{M}$
 - ADHESIVE: $12 \pm 3\mu\text{M}$
 - CU: $25\mu\text{M}$
 - SR: $26 \pm 14\mu\text{M}$
 - FLEX COATING: FS-100L
3. SN PLATING: PURE SN $0.20 \pm 0.05\mu\text{M}$
4. TAP SITE: 4 SPH, 19MM

SSD1881T1R1 TAB PACKAGE DIMENSION – 2

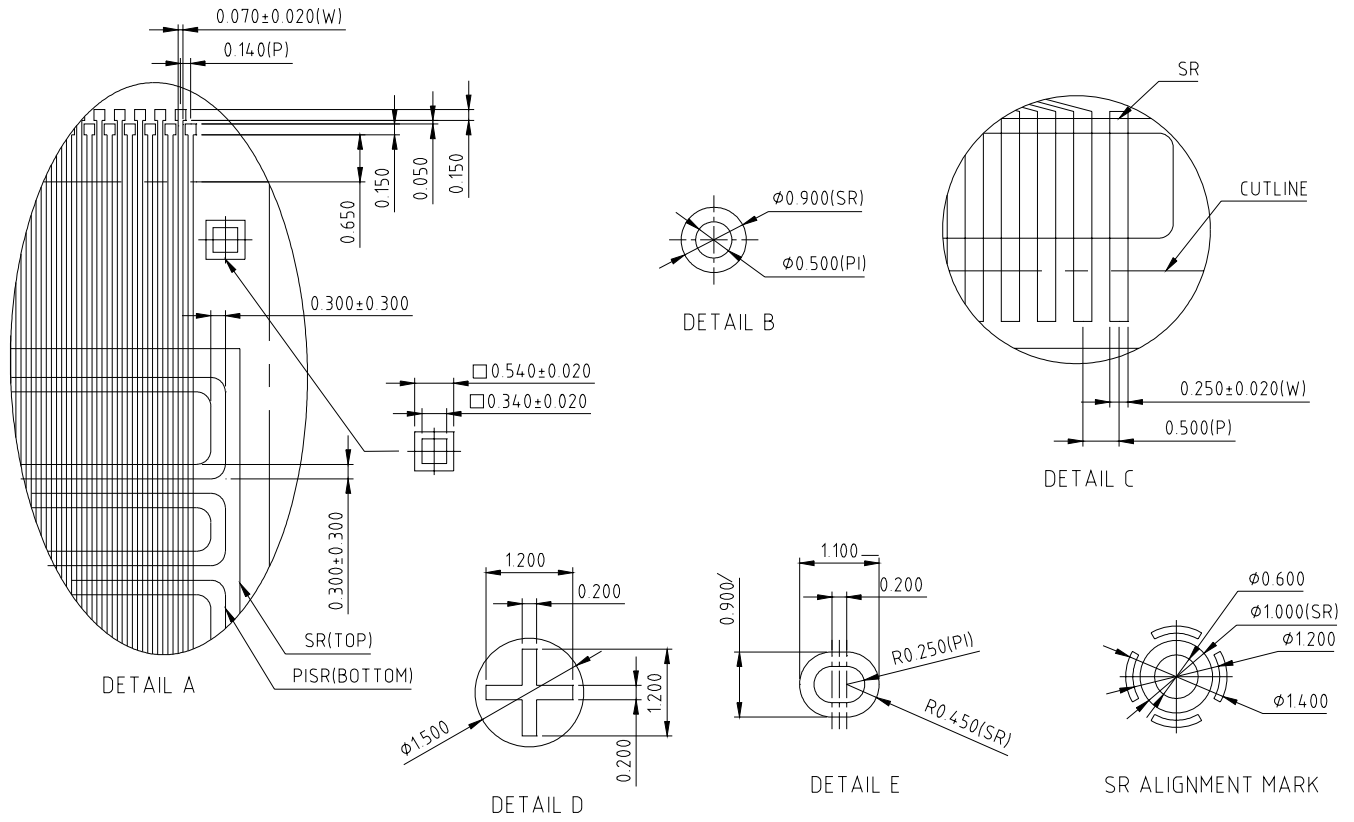

SSD1881T2R TAB PACKAGE DIMENSION – 1

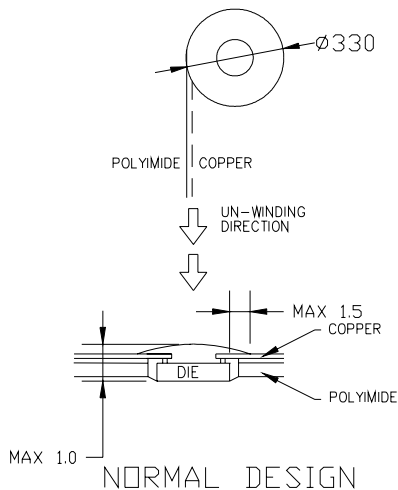
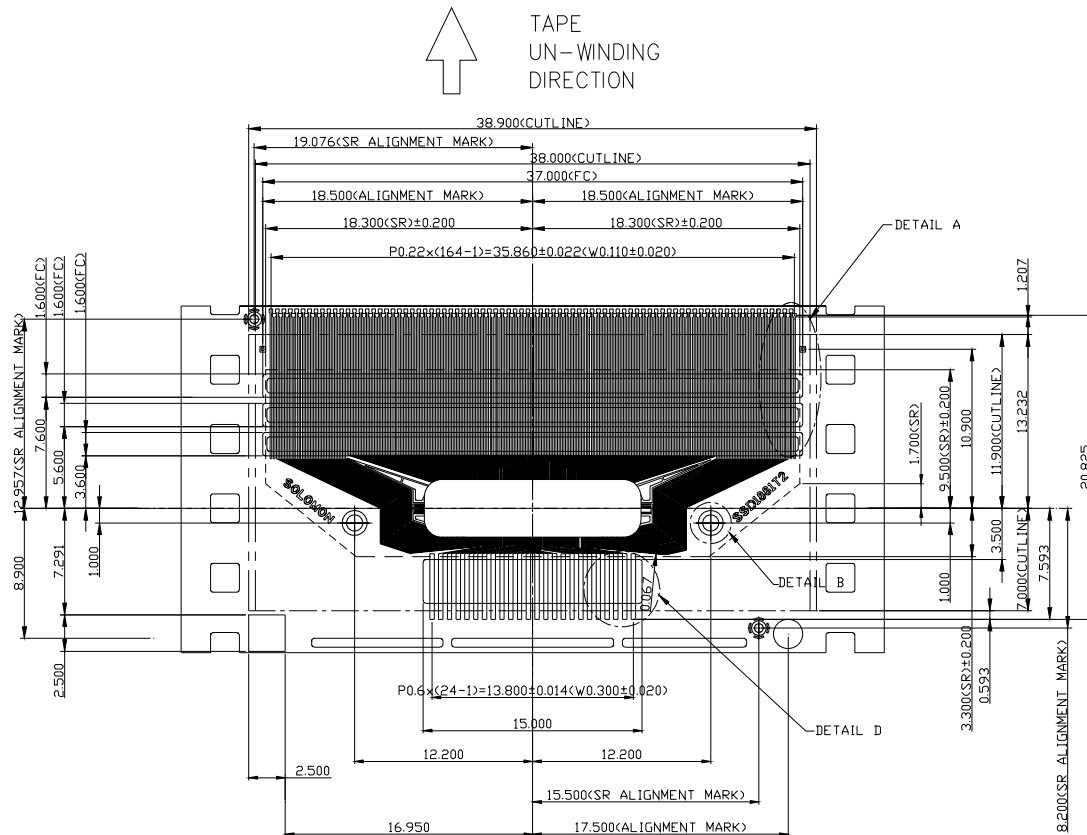

NOTE:

1. GENERAL TOLERANCE: ±0.05MM
2. MATERIAL
 PI: UPILEX 75±6UM
 ADHESIVE: 12±2UM
 CU: 25UM
 SR: 26±14UM
 FLEX COATING: FS-100L
3. SN PLATING: PURE SN 0.20±0.05UM
4. TAPSITE: 5 SPH, 23.75MM

SSD1881T2R TAB PACKAGE DIMENSION – 2

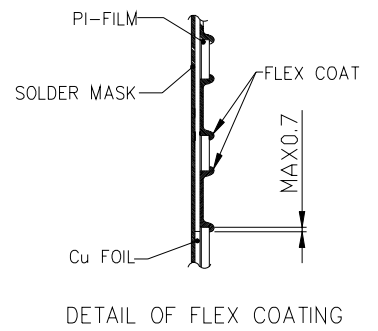
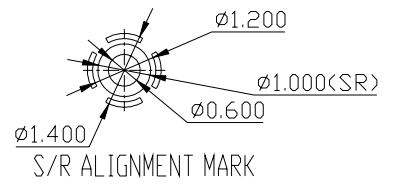
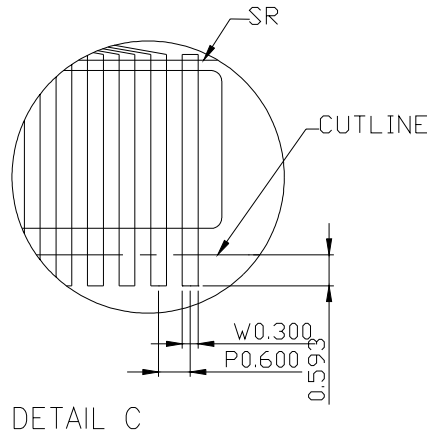
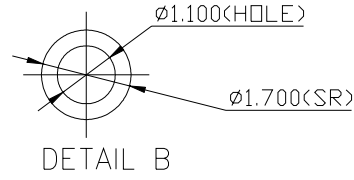
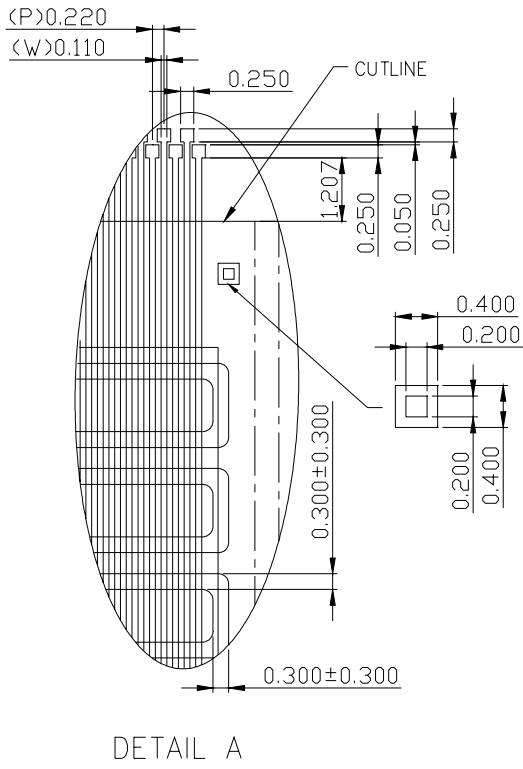

Solomon Systech reserves the right to make changes without further notice to any products herein. Solomon Systech makes no warranty, representation or guarantee regarding the suitability of its products for any particular purpose, nor does Solomon Systech assume any liability arising out of the application or use of any product or circuit, and specifically disclaims any and all liability, including without limitation consequential or incidental damages. "Typical" parameters can and do vary in different applications. All operating parameters, including "Typicals" must be validated for each customer application by customer's technical experts. Solomon Systech does not convey any license under its patent rights nor the rights of others. Solomon Systech products are not designed, intended, or authorized for use as components in systems intended for surgical implant into the body, or other applications intended to support or sustain life, or for any other application in which the failure of the Solomon Systech product could create a situation where personal injury or death may occur. Should Buyer purchase or use Solomon Systech products for any such unintended or unauthorized application, Buyer shall indemnify and hold Solomon Systech and its offices, employees, subsidiaries, affiliates, and distributors harmless against all claims, costs, damages, and expenses, and reasonable attorney fees arising out of, directly or indirectly, any claim of personal injury or death associated with such unintended or unauthorized use, even if such claim alleges that Solomon Systech was negligent regarding the design or manufacture of the part.