

DESCRIPTION

The SSGSC34119 is a low power audio amplifier integrated circuit intended (primarily) for telephone applications, such as in speakerphones. It provides differential speaker outputs to maximize output swing at low supply voltages (2.0V minimum). Coupling capacitors to the speaker are not required. Open loop gain is 80 dB, and the closed loop gain is set with two external resistors. A Chip Disable pin permits powering down and/or muting the input signal.

FEATURES

- Wide Operating Supply Voltage Range (2.0V to 16V), allows Telephone Line Powered Applications
- Low Quiescent Supply Current (2.7mA Typ) for Battery Powered Applications
- Chip Disable Input to Power Down the IC
- Low Power-Down Quiescent Current (65µA Typ)
- Drives a Wide Range of Speaker Loads (8.0Ω and Up)
- Output Power Exceeds 250 mW with 32Ω Speaker
- Low Total Harmonic Distortion (0.5% Typ)
- Gain Adjustable from <0 dB to >46 dB for Voice Band
- Requires Few External Components

PACKAGE DIMENSIONS

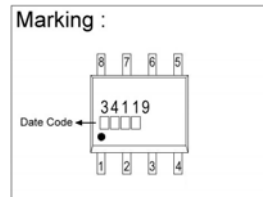
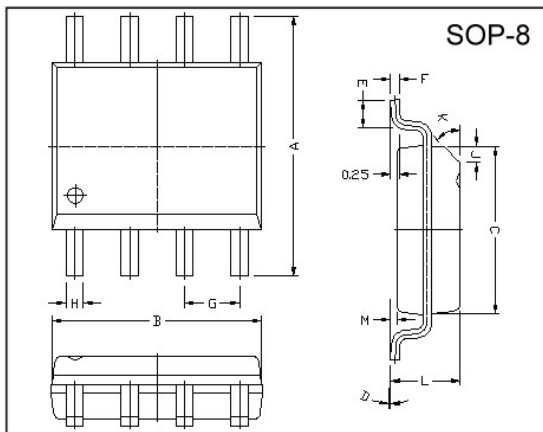

REF.	Millimeter		REF.	Millimeter	
	Min.	Max.		Min.	Max.
A	5.80	6.20	M	0.10	0.25
B	4.80	5.00	H	0.35	0.49
C	3.80	4.00	L	1.35	1.75
D	0	8	J	0.375 REF.	
E	0.40	0.90	K	45	
F	0.19	0.25	G	1.27 TYP.	

BLOCK DIAGRAM AND SIMPLIFIED APPLICATION & PIN CONFIGURATION

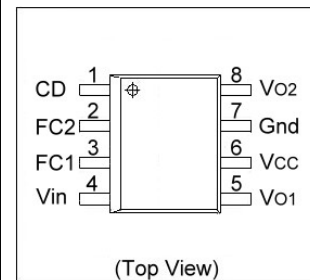
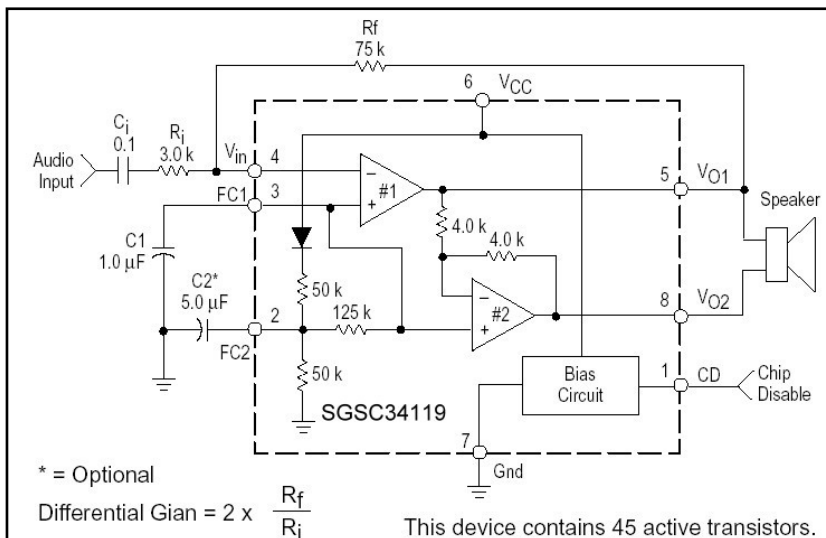

MAXIMUM RATINGS

Parameter	Value	Units
Supply Voltage	-1.0 to +18	V _{DC}
Maximum Output Current at V _{O1} and V _{O2}	±250	mA
Maximum Voltage @ V _{in} , FC1, FC2, CD	-1.0, V _{CC} + 1.0	V _{DC}
Applied Output Voltage to V _{O1} , V _{O2} when disabled	-1.0, V _{CC} + 1.0	V _{DC}
Junction Temperature	-55, +140	°C

Note: ESD data available upon request.

RECOMMENDED OPERATING CONDITIONS

Characteristics	Symbol	Min	Max	Units
Supply Voltage	V _{CC}	+2.0	+16	V _{DC}
Voltage @ CD (Pin 1)	V _{CD}	0	V _{CC}	V _{DC}
Load Impedance	R _L	8.0	-	Ω
Peak Load Current	I _L	-	±200	mA
Differential Gain (5.0 kHz Bandwidth)	AVD	0	46	dB
Ambient Temperature	T _A	-20	+70	°C

ELECTRICAL CHARACTERISTICS (T_A=25 °C unless otherwise specified)

Parameter	Symbol	Test Conditions	Min	Typ	Max	Units
Amplifiers (AC Characteristics)						
AC Input Resistance	R _i	@ V _{in}	-	> 30	-	MΩ
Open Loop Gain	A _{VOL1}	Amplifier #1, f < 100Hz	80	-	-	dB
Close Loop Gain	A _{V2}	Amplifier #2, V _{CC} = 6V, f = kHz, R _L = 32Ω	-0.35	0	+0.35	dB
Gain Bandwidth Product	GBW	-	-	1.5	-	MHz
Output Power	P _{out3} P _{out6} P _{out12}	V _{CC} = 3V, R _L = 16Ω, THD ≤ 10 % V _{CC} = 6V, R _L = 32Ω, THD ≤ 10 % V _{CC} = 12V, R _L = 100Ω, THD ≤ 10 %	55 250 400	- - -	- - -	mW
Total Harmonic Distortion (f = 1 kHz)	THD	V _{CC} = 6V, R _L = 32Ω, P _{out} = 125 mW V _{CC} ≥ 3V, R _L = 8Ω, P _{out} = 20 mW V _{CC} ≥ 12V, R _L = 32Ω, P _{out} = 200 mW	- - -	0.5 0.5 0.6	1.0 - -	%
Power Supply Rejection (V _{CC} = 6V, ΔV _{CC} = 3V)	PSRR	C1 = ∞, C2 = 0.0μF C1 = 0.1 μF, C2 = 0, f = 1 kHz C1 = 1.0 μF, C2 = 5.0 μF, f = 1 kHz	50 - -	- 12 52	- - -	dB
Differential Muting	GMT	V _{CC} = 6V, 1 kHz ≤ f ≤ 20 kHz, CD = 2V	-	>70	-	dB
Amplifiers (DC Characteristics)						
Output DC Level	V _{O(3)} V _{O(6)} V _{O(12)}	V _{O1} , V _{O2} , V _{CC} = 3V, R _L = 16Ω (R _f =75k) V _{CC} = 6V V _{CC} = 12V	1.0 - -	1.15 2.65 5.65	1.25 - -	V _{DC}
Output Level	V _{OH} V _{OL}	High I _{out} = -75mA, 2V ≤ V _{CC} ≤ 16V Low I _{out} = 75mA, 2V ≤ V _{CC} ≤ 16V	- -	V _{CC} -1 0.16	- -	V _{DC}
Output DC Offset Voltage (V _{O1} - V _{O2})	ΔV _O	V _{CC} = 6V, R _f = 75kΩ, R _L = 32Ω	-30	0	+30	mV
Input Bias Current	I _{IB}	V _{in} (V _{CC} =6V)	-	-100	-200	nA
Equivalent Resistance	R _{FC1} R _{FC2}	FC1 (V _{CC} = 6V) FC2 (V _{CC} = 6V)	100 18	150 25	220 40	kΩ

ELECTRICAL CHARACTERISTICS (Cont'd)

Parameter	Symbol	Test Conditions	Min	Typ	Max	Units
Chip Disable (Pin1)						
Input Voltage	V_{IL}	Low	-	-	0.8	V_{DC}
	V_{IH}	High	2.0	-	-	
Input Resistance	R_{CD}	$V_{CC} = V_{CD} = 16V$	50	90	175	$k\Omega$
Power Supply						
Power Supply Current	I_{CC3}	$V_{CC} = 3V, R_L = \infty, CD = 0.8V$	-	2.7	4.0	mA
	I_{CC16}	$V_{CC} = 16V, R_L = \infty, CD = 0.8V$	-	3.3	5.0	mA
	I_{CCD}	$V_{CC} = 3V, R_L = \infty, CD = 2.0V$	-	65	100	μA

Note: Currents into a pin are positive; currents out of a pin are negative.

PIN FUNCTION DESCRIPTION

Symbol	Pin	Description
CD	1	Chip Disable-Digital input. A Logic "0" ($<0.8V$) sets normal operation. A Logic "1" ($\geq 2V$) sets the power down mode. Input impedance is nominally $90k\Omega$.
FC2	2	A capacitor at this pin increases power supply rejection, and affects turn-on time. This pin can be left open if the capacitor at FC1 is sufficient.
FC1	3	Analog ground for the amplifiers. A $1.0\mu F$ capacitor at this pin (with a $5.0\mu F$ capacitor at Pin 2) provides (typically) 52dB of power supply rejection. Turn-on time of the circuit is affected by the capacitor on this pin. This pin can be used as an alternate input.
V_{in}	4	Amplifier input. This input capacitor and resistor set low frequency roll-off and input impedance. The feedback resistor is connected to this pin and V_{O1} .
V_{O1}	5	Amplifier Output #1. The dc level is $\approx (V_{CC} - 0.7)/2$.
V_{CC}	6	DC supply voltage (+2V to +16V) is applied to this pin.
GND	7	Ground pin for the entire circuit.
V_{O2}	8	Amplifier Output #2. This signal is equal in amplitude, but 180° out-of-phase with that at V_{O1} . The dc level is $\approx (V_{CC} - 0.7)/2$.

TYPICAL TEMPERATURE PERFORMANCE ($-20^\circ C < T_A < +70^\circ C$)

Function	Typical Change	Units
Input Bias Current (@ V_{in})	± 40	$pA/^\circ C$
Total Harmonic Distortion ($V_{CC} = 6V, R_L = 32\Omega, P_{out} = 125 mW, f = kHz$)	+0.003	$\%/^\circ C$
Power Supply Current ($V_{CC} = 3V, R_L = \infty, CD = 0V$) ($V_{CC} = 3V, R_L = \infty, CD = 2V$)	-0.25 -0.03	$\mu A/^\circ C$

Design Guidelines

General

The SSGSC34119 is a low power audio amplifier capable of low voltage operation ($V_{CC} = 2.0 V$ minimum) such as that encountered in line-powered speakerphones. The circuit provides a differential output ($V_{O1}-V_{O2}$) to the speaker to maximize the available voltage swing at low voltages. The differential gain is set by two external resistors. Pins FC1 and FC2 allow controlling the amount of power supply and noise rejection, as well as providing alternate inputs to the amplifiers. The CD pin permits powering down the IC for muting purposes and to conserve power.

Amplifiers

Referring to the block diagram, the internal configuration consists of two identical operational amplifiers. Amplifier # 1 has an open loop gain of $\geq 80 dB$ (at $f \leq 100 Hz$), and the closed loop gain is set by external resistor R_f and R_i . The amplifier is unity gain stable, and has a unity gain frequency of approximately 1.5 MHz. In order to adequately cover the telephone voice band (300 Hz to 3400 Hz), a maximum closed loop gain of 46 is recommended. Amplifier #2 is internally set to a gain of -1.0(0dB).

The outputs of both amplifiers are capable of sourcing and sinking a peak current of 200 mA. The outputs can typically swing to within ≈ 0.4 V above ground, and to with ≈ 1.3 V below V_{CC} , at the maximum current. See Figures 17 and 18 for V_{OH} and V_{OL} curves.

The output dc offset voltage ($V_{O1}-V_{O2}$) is primarily a function of the feedback resistor (R_f), and secondarily due to the amplifiers' input offset voltages. The input offset voltage of the two amplifiers will generally be similar for a particular IC, and therefore nearly cancel each other at the outputs. Amplifier #1's bias current, however, flows out of V_{in} (Pin 4) and through R_f , forcing V_{O1} to shift negative by an amount equal to $[R_f \times I_{B1}]$. V_{O2} is shifted positive an equal amount. The output offset voltage, specified in the Electrical Characteristics, is measured with the feedback resistor shown in the Typical Application Circuit, and therefore takes into account the bias current as well as internal offset voltages of the amplifiers. The bias current is constant with respect to V_{CC} .

FC1 and FC2

Power supply rejection is provided by the capacitors (C1 and C2 in the Typical Application Circuit) at FC1 and FC2. C2 is somewhat dominant at low frequencies, while C1 is dominant at high frequencies, as shown in the graphs of Figures 4 to 7. The required values of C1 and C2 depend on the conditions of each application. A line powered speakerphone, for example, will require more filtering than a circuit powered by a well regulated power supply. The amount of rejection is a function of the capacitors, and the equivalent impedance looking into FC1 and FC2 (listed in the Electrical Characteristics as R_{FC1} and R_{FC2}).

In addition to providing filtering, C1 and C2 also affect the turn-on time of the circuit at power-up, since the two capacitors must charge up through the internal 50 k Ω and 125 k Ω resistors. The graph of Figure 1 indicates the turn-on time upon application of V_{CC} of + 6.0 V. The turn-on time is $\approx 60\%$ longer for $V_{CC} = 3.0$ V, and $\approx 20\%$ less for $V_{CC} = 9.0$ V. Turn-off time is < 10 us upon removal of V_{CC} .

Chip Disable

The Chip Disable (Pin 1) can be used to power down the IC to conserve power, or for muting, or both. When at a Logic "0" (0 V to 0.8 V), the SGSC34119 is enabled for normal operation. When Pin 1 is at a Logic "1" (2.0 V to V_{CC} V), the IC is disabled. If Pin 1 is open, that is equivalent to a Logic "0", although good design practice dictates that an input should never be left open. Input impedance at Pin 1 is a nominal 90 k Ω . The power supply current (when disabled) is shown in Figure 19.

Muting, defined as the change in differential gain from normal operation to muted operation, is in excess of 70 dB. The turn-off time of the audio output, from the application of the CD signal, is < 2.0 μ s, and turn on-time is 12 ms-15 ms. Both times are independent of C1, C2, and V_{CC} .

When the SGSC34119 is disabled, the voltages at FC1 and FC2 do not change as they are powered from V_{CC} . The outputs, V_{O1} and V_{O2} , change to a high impedance condition, removing the signal from the speaker. If signals from other sources are to be applied to the outputs (while disabled), they must be within the range of V_{CC} and Ground.

Power Dissipation

Figures 8 to 10 indicate the device dissipation (within the IC) for various combinations of V_{CC} , R_L , and load power. The maximum power which can safely be dissipated within the SGSC34119 is found from the following equation: $P_D = (140^\circ\text{C}-T_A)/\theta J_A$ where T_A is the ambient temperature; and θJ_A is the package thermal resistance (100 $^\circ\text{C}/\text{W}$ for the standard DIP package.)

The power dissipated within the SGSC34119, in a given application, is found from the following equation:

$P_D = (V_{CC} \times I_{CC}) + (I_{RMS} \times V_{CC}) - (R_L \times I_{RMS}^2)$ where I_{CC} is obtained from Figure 19; and I_{RMS} is the RMS current at the load; and R_L is the load resistance.

Figures 8 to 10, along with Figures 11 to 13 (distortion curves), and a peak working load current of ± 200 mA, define the operating range for the SGSC34119. The operating range is further defined in terms of allowable load power in Figure 14 for loads of 8.0 Ω , 16 Ω and 32 Ω . The left (ascending) portion of each of the three curves is defined by the power level at which 10% distortion occurs. The center flat portion of each curve is defined by the maximum output current capability of the SGSC34119. The right (descending) portion of each curve is defined by the maximum internal power dissipation of the IC at 25 $^\circ\text{C}$. At higher ambient temperatures, the maximum load power must be reduced according to the above equations. Operating the device beyond the current and junction temperature limits will degrade long term reliability.

Layout Considerations

Normally a snubber is not needed at the output of the SGSC34119, unlike many other audio amplifiers. However, the PC board layout, stray capacitances, and the manner in which the speaker wires are configured, may dictate otherwise. Generally, the speaker wires should be twisted tightly and not more than a few inches in length.

CHARACTERISTIC CURVE

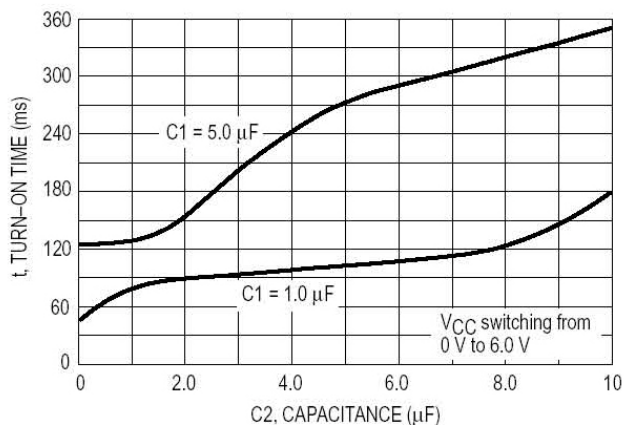

Fig 1. Turn-On Time versus C1, C2 at Power-On

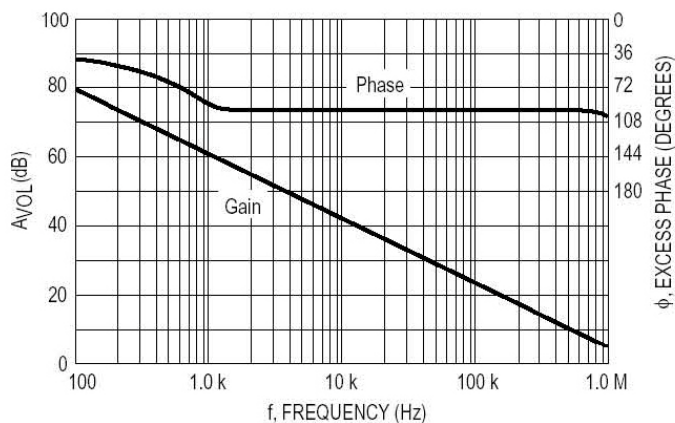

Fig 2. Amplifier #1 Open Loop Gain and Phase

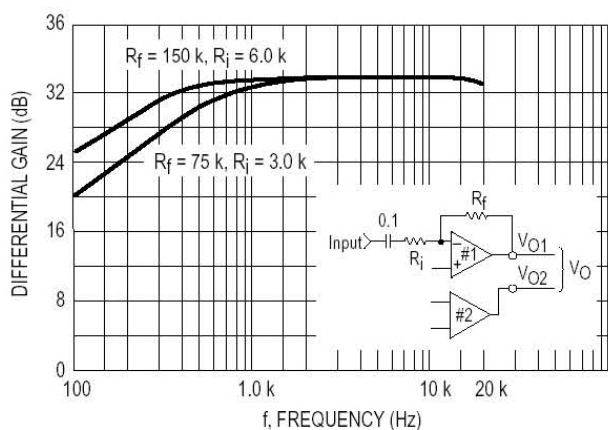

Fig 3. Differential Gain versus Frequency

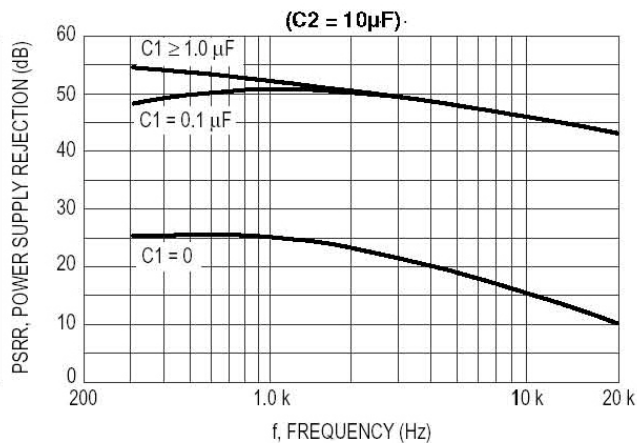

Fig 4. Power Supply Rejection versus Frequency

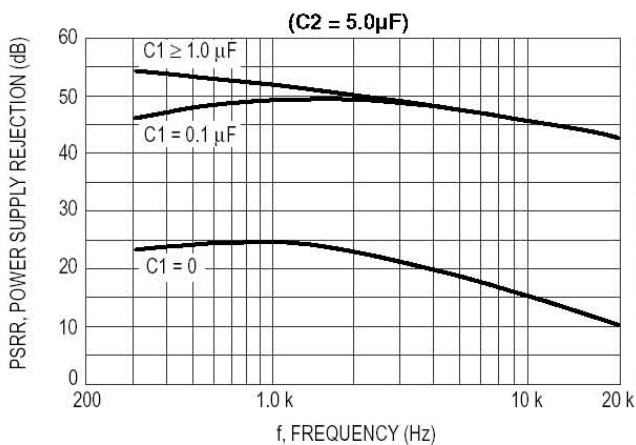

Fig 5. Power Supply Rejection versus Frequency

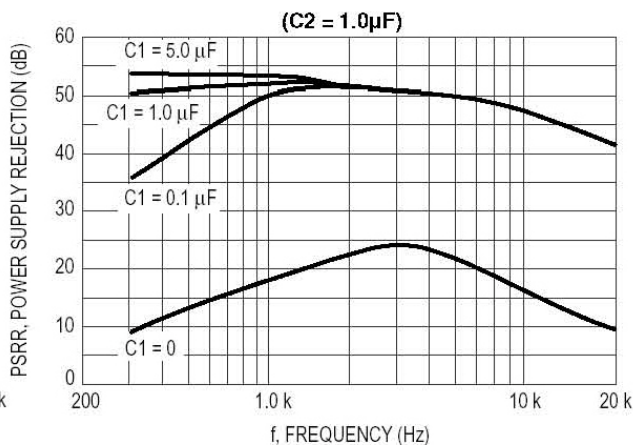

Fig 6. Power Supply Rejection versus Frequency

CHARACTERISTIC CURVE (cont'd)

Fig 5. Power Supply Rejection versus Frequency

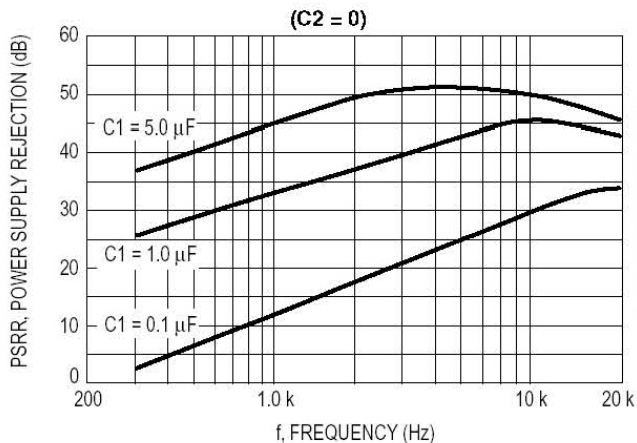

Fig 6. Power Supply Rejection versus Frequency

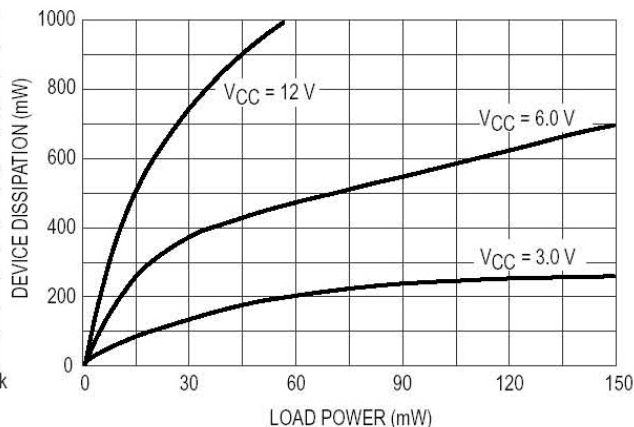

Fig 7. Power Supply Rejection versus Frequency

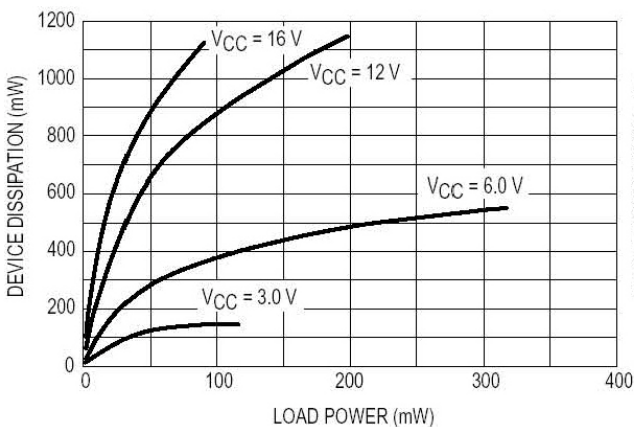

Fig 8. Device Dissipation, 8.0 Ω Load

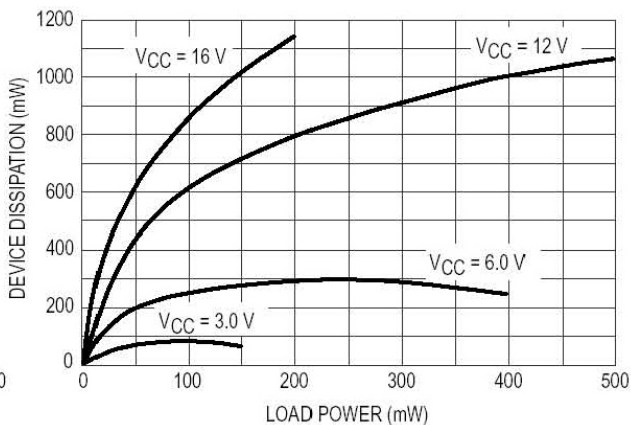

Fig 9. Device Dissipation, 16 Ω Load

Fig 10. Device Dissipation, 32 Ω Load

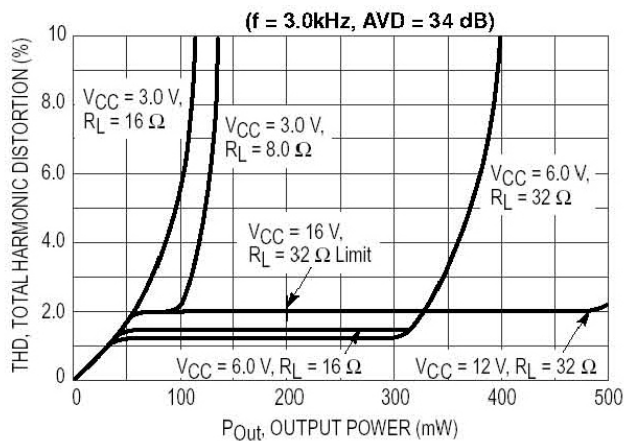
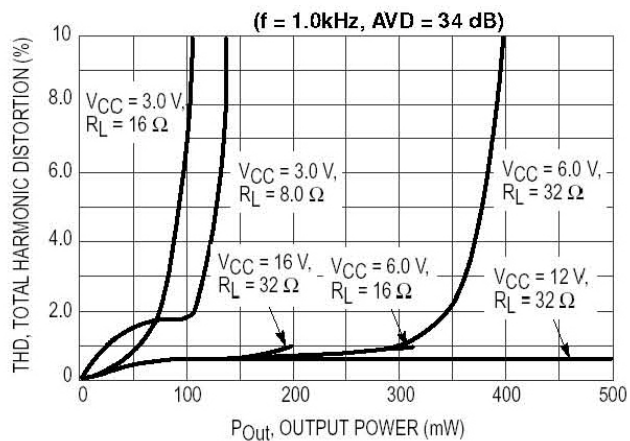

Fig 11. Distortion versus Power

Fig 12. Distortion versus Power

CHARACTERISTIC CURVE (cont'd)

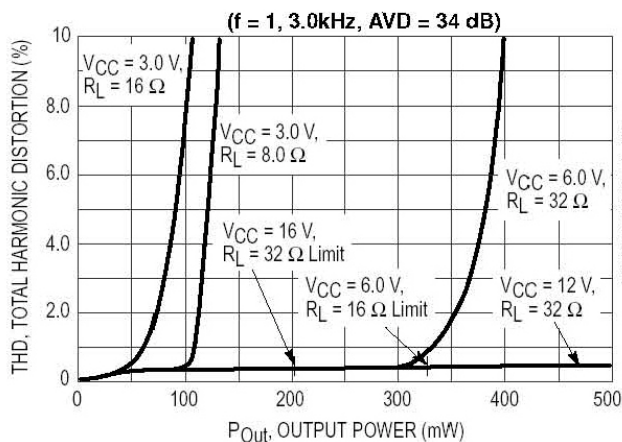

Fig 13. Distortion versus Power

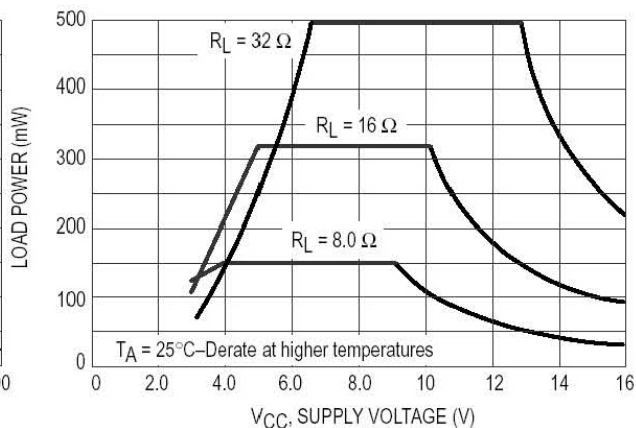

Fig 14. Maximum Allowable Load Power

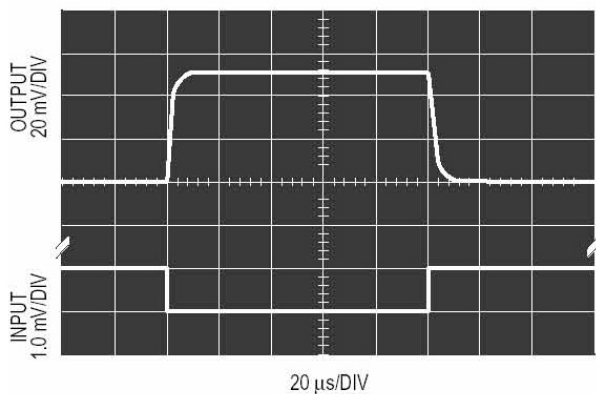

Fig 15. Small Signal Response

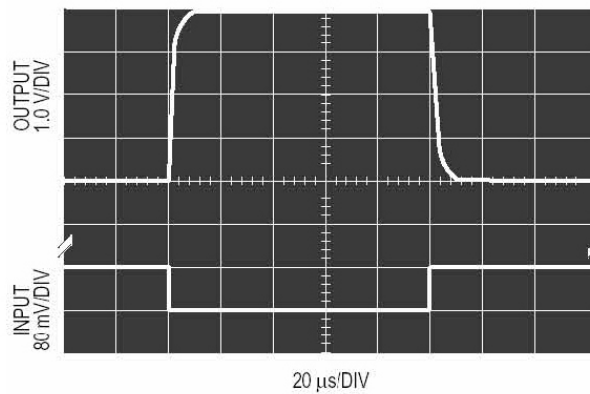

Fig 16. Large Signal Response

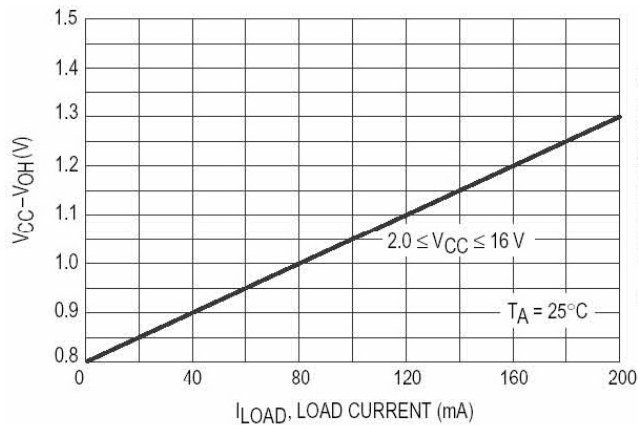

Fig 17. $V_{CC} - V_{OH}$ @ V_{O1} , V_{O2} versus Load Current

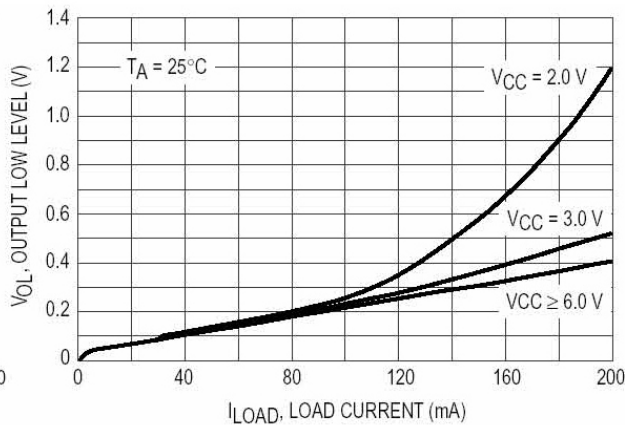

Fig 18. V_{OL} @ V_{O1} , V_{O2} versus Load Current

CHARACTERISTIC CURVE (cont'd)

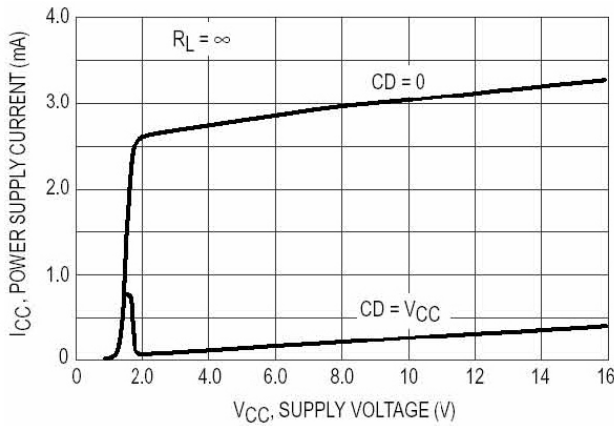

Fig 19. Power Supply Current

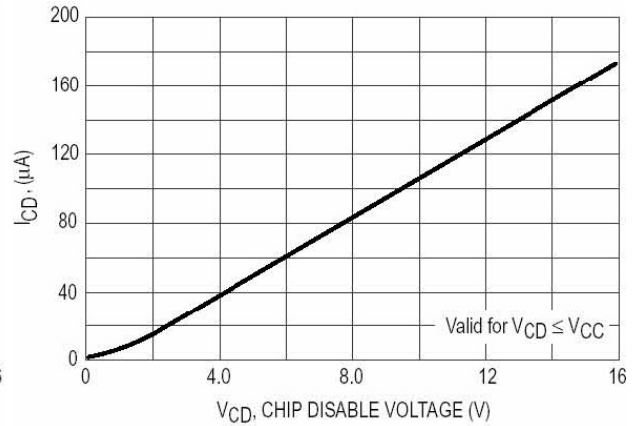

Fig 20. Input Characteristics @ CD (Pin 1)

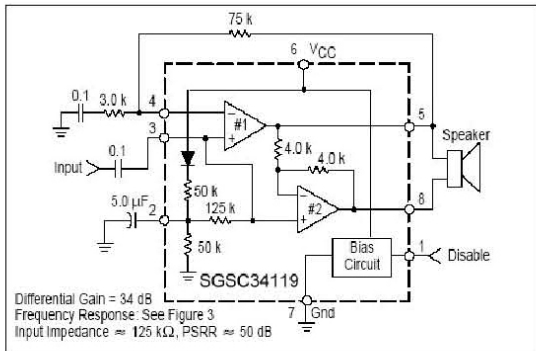
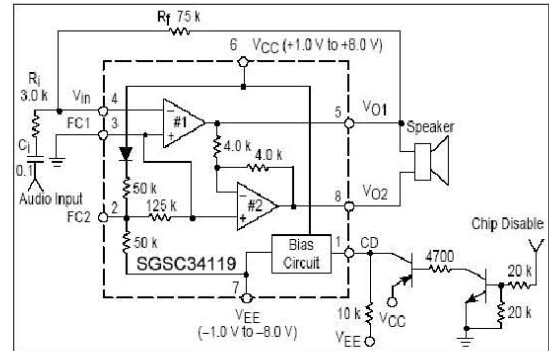

Fig 21. Audio Amplifier with High Input Impedance



Note: If V_{CC} and V_{EE} are not symmetrical about ground then FC1 must be connected through a capacitor to ground as shown on the front page.

Fig 22. Split Supply Operation

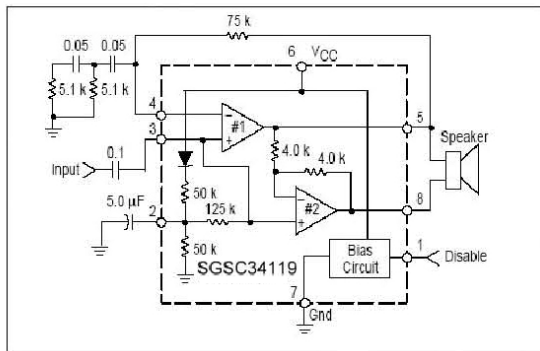

Fig 23. Audio Amplifier with Bass Suppression

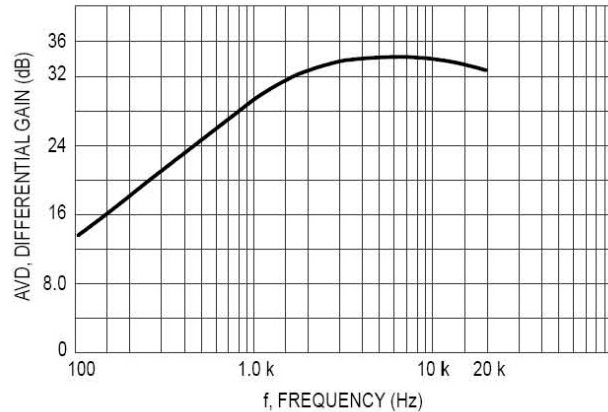

Fig 24. Frequency Response of Fig 23

CHARACTERISTIC CURVE (cont'd)

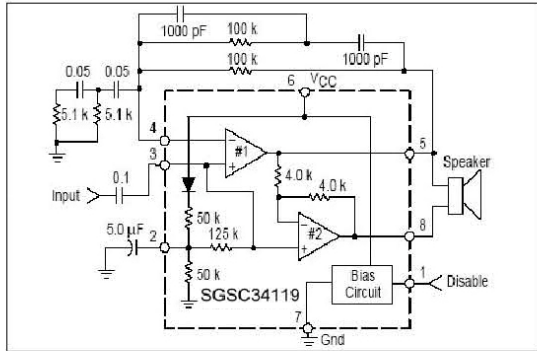

Fig 25. Audio Amplifier with Bandpass

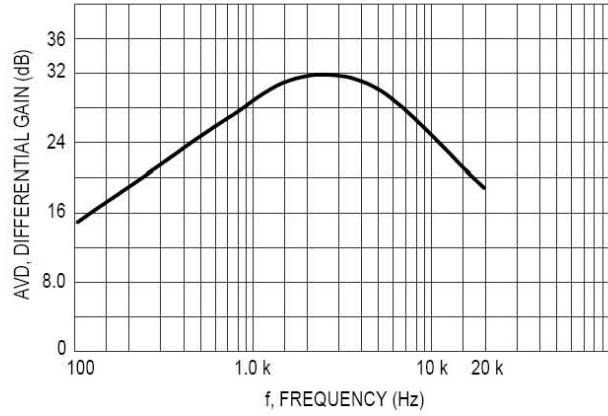

Fig 26. Frequency Response of Fig 25