

RoHS Compliant Product
A suffix of "-C" specifies halogen & lead-free

FEATURES

- Low $R_{DS(on)}$ trench technology.
- Low thermal impedance.
- Fast switching speed.

APPLICATIONS

- White LED boost converters.
- Automotive Systems.
- Industrial DC/DC Conversion Circuits.

PACKAGE INFORMATION

Package	MPQ	Leader Size
SOP-8PP	3K	7' inch

SOP-8PP

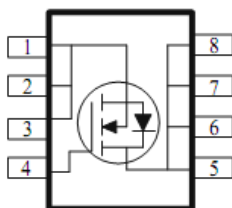
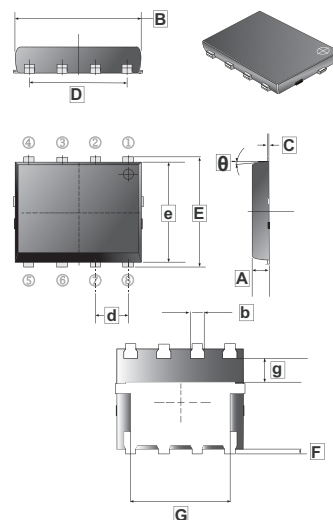

REF.	Millimeter		REF.	Millimeter	
	Min.	Max.		Min.	Max.
A	1.00	1.10	θ	0°	12°
B	5.70	5.80	b	0.33	0.51
C	0.20	0.30	d	1.27BSC	
D	3.61	3.98	e	1.35	1.75
E	5.40	6.10	g	1.10	-
F	0.08	0.20			
G	3.60	3.99			

ABSOLUTE MAXIMUM RATINGS ($T_A=25^\circ\text{C}$ unless otherwise specified)

Parameter	Symbol	Rating	Unit
Drain-Source Voltage	V_{DS}	150	V
Gate-Source Voltage	V_{GS}	± 20	V
Continuous Drain Current ¹	I_D	$T_A=25^\circ\text{C}$	3.6
		$T_A=70^\circ\text{C}$	2.9
Pulsed Drain Current ²	I_{DM}	20	A
Continuous Source Current (Diode Conduction) ¹	I_S	6.2	A
Power Dissipation ¹	P_D	$T_A=25^\circ\text{C}$	5
		$T_A=70^\circ\text{C}$	3.2
Operating Junction and Storage Temperature Range	T_J, T_{STG}	-55~150	$^\circ\text{C}$
Thermal Resistance Data			
Maximum Junction to Ambient ¹	$R_{\theta JA}$	$t \leq 10$ sec	25
		Steady State	65

Notes:

1. Surface Mounted on 1" x 1" FR4 Board.
2. Pulse width limited by maximum junction temperature.

ELECTRICAL CHARACTERISTICS ($T_A=25^\circ\text{C}$ unless otherwise specified)

Parameter	Symbol	Min	Typ	Max	Unit	Test condition
Static						
Gate-Threshold Voltage	$V_{GS(th)}$	1	-	-	V	$V_{DS}=V_{GS}$, $I_D=250\mu\text{A}$
Gate-Body Leakage	I_{GSS}	-	-	± 10	nA	$V_{DS}=0$, $V_{GS}=\pm 20\text{V}$
Zero Gate Voltage Drain Current	I_{DSS}	-	-	1	μA	$V_{DS}=120\text{V}$, $V_{GS}=0$
		-	-	10		$V_{DS}=120\text{V}$, $V_{GS}=0$, $T_J=55^\circ\text{C}$
On-State Drain Current ¹	$I_{D(ON)}$	10	-	-	A	$V_{DS}=5\text{V}$, $V_{GS}=10\text{V}$
Drain-Source On-Resistance ¹	$R_{DS(ON)}$	-	-	255	m Ω	$V_{GS}=10\text{V}$, $I_D=2.9\text{A}$
		-	-	290		$V_{GS}=4.5\text{V}$, $I_D=2.7\text{A}$
Forward Transconductance ¹	g_{FS}	-	10	-	S	$V_{DS}=15\text{V}$, $I_D=2.9\text{A}$
Diode Forward Voltage	V_{SD}	-	0.76	-	V	$I_S=3.1\text{A}$, $V_{GS}=0$
Dynamic ²						
Total Gate Charge	Q_g	-	10.8	-	nC	$I_D=2.9\text{A}$ $V_{DS}=75\text{V}$ $V_{GS}=4.5\text{V}$
Gate-Source Charge	Q_{gs}	-	3.3	-		
Gate-Drain Charge	Q_{gd}	-	5.6	-		
Turn-On Delay Time	$T_{d(ON)}$	-	10.1	-	nS	$I_D=2.9\text{A}$, $V_{DD}=75\text{V}$ $V_{GEN}=10\text{V}$ $R_L=25.9\Omega$, $R_{GEN}=6\Omega$
Rise Time	T_r	-	10	-		
Turn-Off Delay Time	$T_{d(OFF)}$	-	50	-		
Fall Time	T_f	-	22	-		
Input Capacitance	C_{iss}	-	848	-	pF	$V_{DS}=15\text{V}$, $V_{GS}=0$, $f=1\text{MHz}$
Output Capacitance	C_{oss}	-	69	-		
Reverse Transfer Capacitance	C_{riss}	-	29	-		

Notes:

1. Pulse test : $PW \leq 300\mu\text{s}$ duty cycle $\leq 2\%$.
2. Guaranteed by design, not subject to production testing.

ELECTRICAL CHARACTERISTICS CURVE

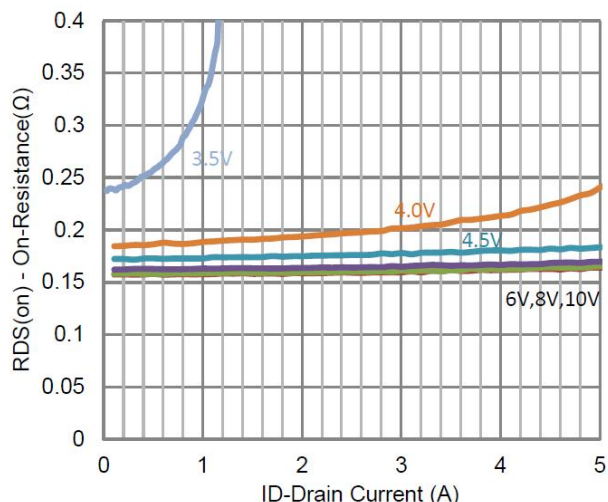

1. On-Resistance vs. Drain Current

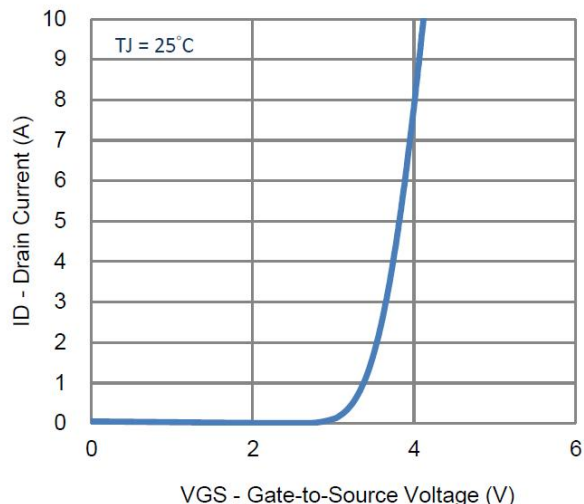

2. Transfer Characteristics

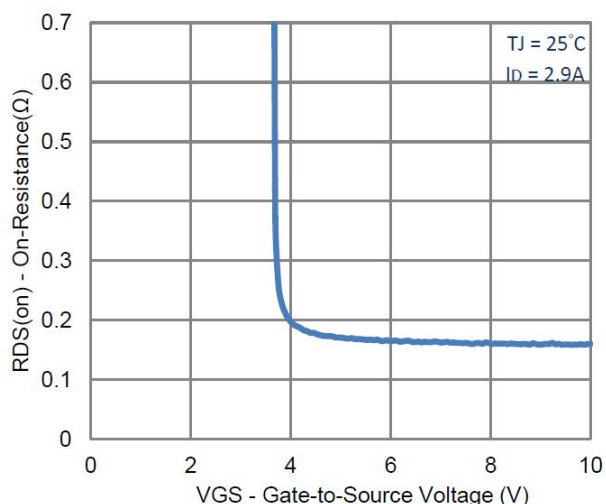

3. On-Resistance vs. Gate-to-Source Voltage

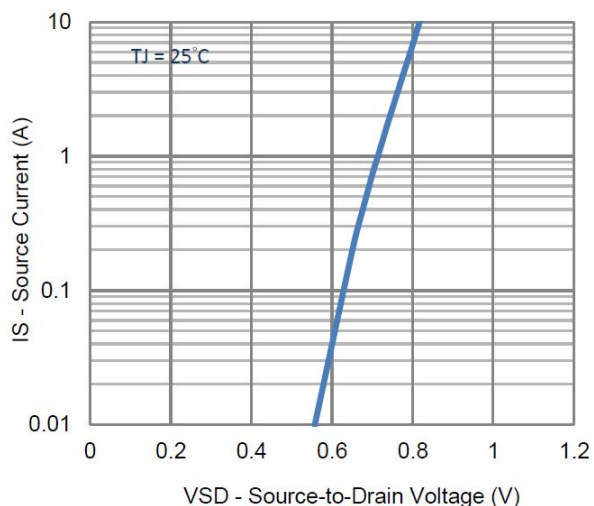

4. Drain-to-Source Forward Voltage

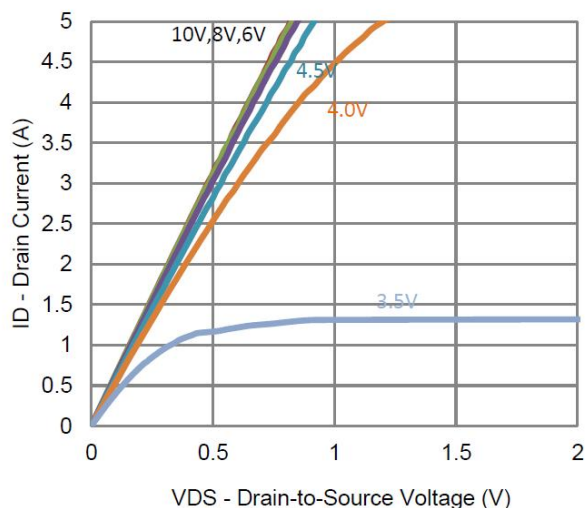

5. Output Characteristics

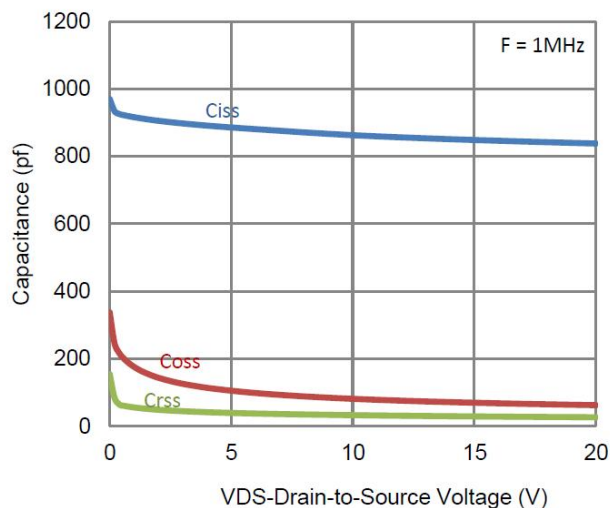

6. Capacitance

ELECTRICAL CHARACTERISTICS CURVE

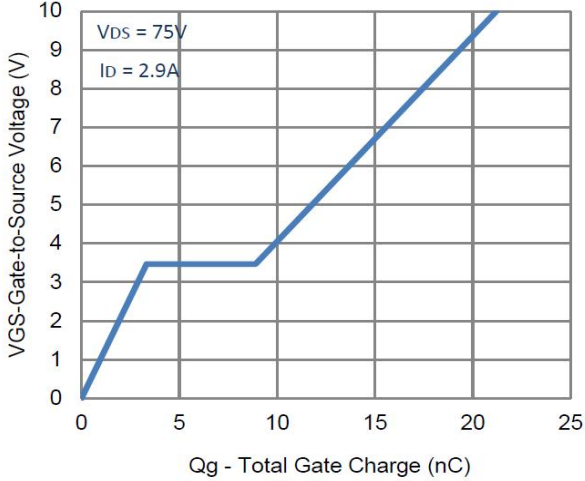

7. Gate Charge

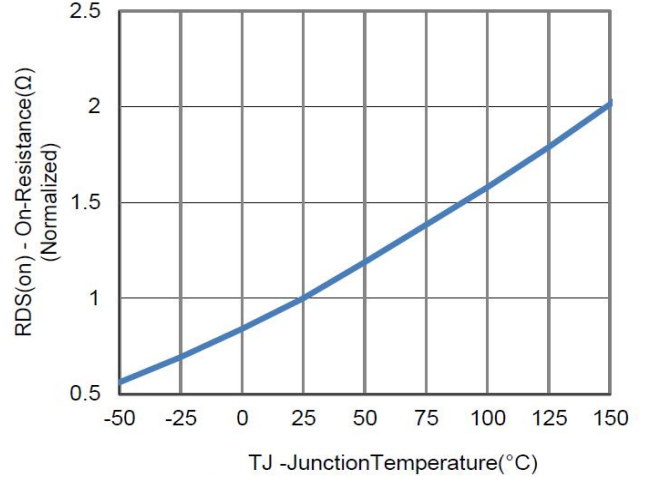

8. Normalized On-Resistance Vs Junction Temperature

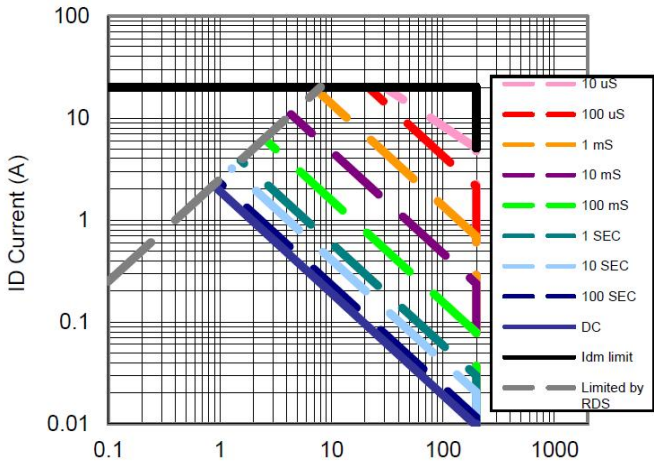

9. Safe Operating Area

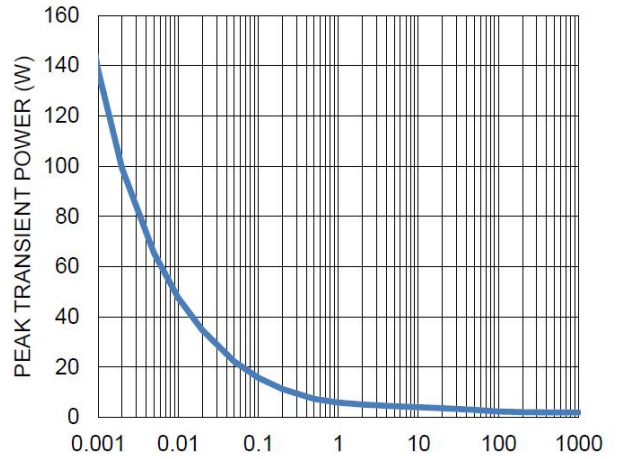

10. Single Pulse Maximum Power Dissipation

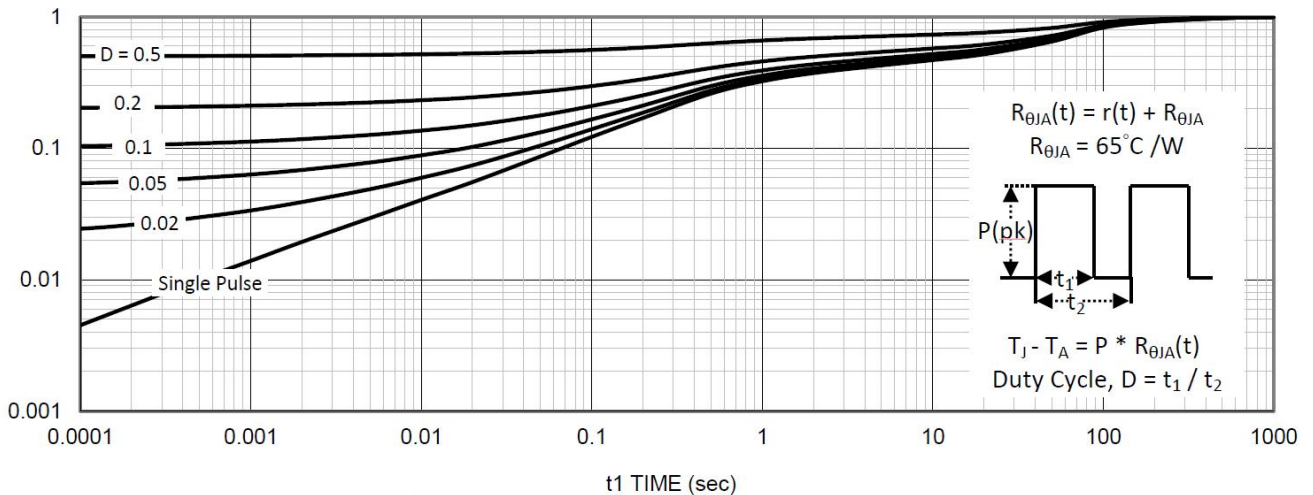

11. Normalized Thermal Transient Junction to Ambient