

CMOS quad tri-state differential line driver

General features

- TTL input compatible
- Typical propagation delay: 6ns
- Typical output skew: 0.5ns
- Output will not load line when $V_{CC} = 0V$
- Meets the requirements of EIA standard RS-422
- Operation from single 5V supply
- 3-state outputs for connection to system buses
- Low quiescent current
- Available in surface mount

Description

The ST26C31 is a quad differential line driver designed for digital data transmission over balanced lines and meets all the requirements of EIA standard RS-422 while retaining the low power characteristics of CMOS.

The ST26C31 accepts TTL or CMOS input levels and translates these to RS-422 output levels. This part uses special outputs circuitry common to all four drivers. All outputs are protected against damage due to electrostatic discharge by diode to V_{CC} and ground.

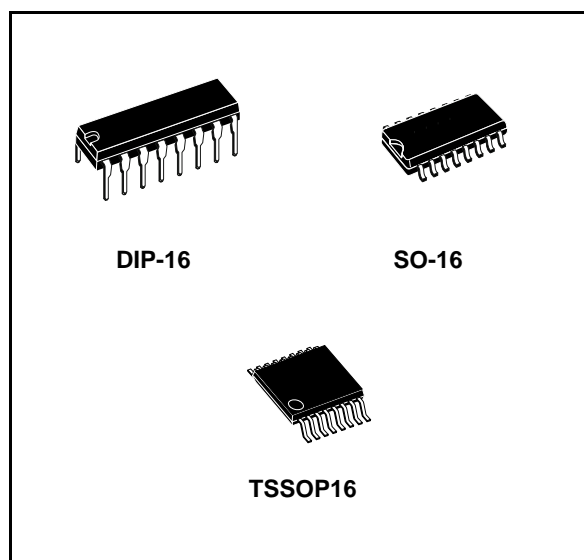

Order code

Part number	Temperature range	Package	Packaging
ST26C31BN	-40 to 85 °C	DIP-16	25 parts per tube / 40 tube per box
ST26C31BDR	-40 to 85 °C	SO-16 (Tape & Reel)	2500 parts per reel
ST26C31BTR	-40 to 85 °C	TSSOP16 (Tape & Reel)	2500 parts per reel

Contents

1	Pin configuration	3
2	Maximum ratings	5
3	Electrical characteristics	6
4	Package mechanical data	8
5	Revision history	14

1 Pin configuration

Figure 1. Pin connections

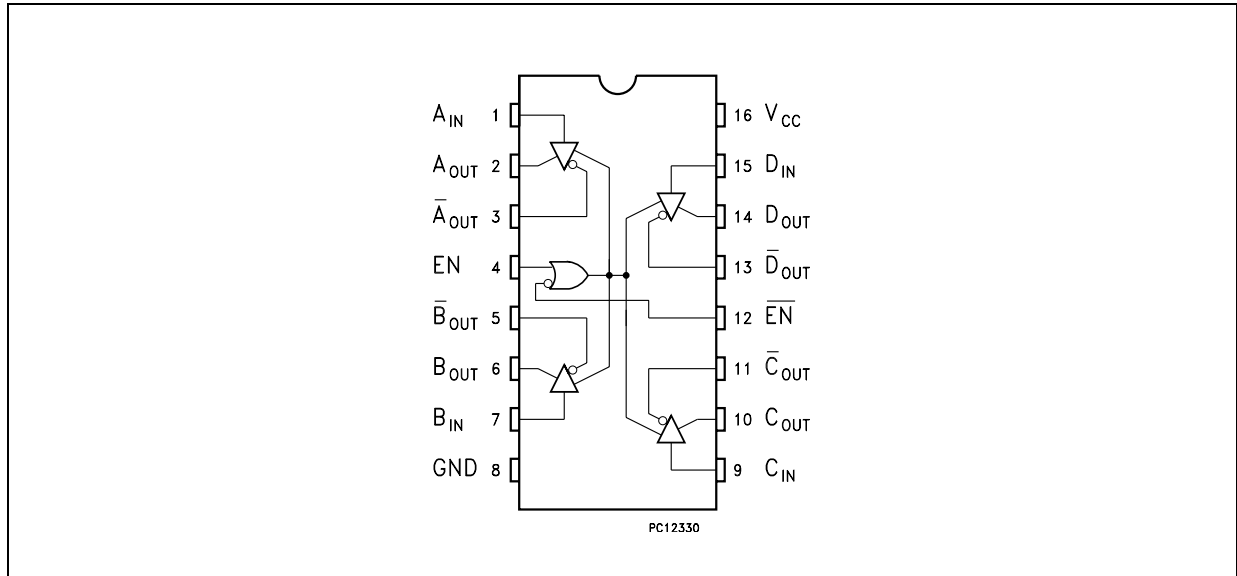

Table 1. Pin description

Pin n°	Symbol	Name and function
1	A _{IN}	INPUT A
2	A _{OUT}	Channel A Output
3	\bar{A}_{OUT}	Channel A Output
4	EN	ENABLE
5	\bar{B}_{OUT}	Channel B Output
6	B _{OUT}	Channel B Output
7	B _{IN}	INPUT B
8	GND	Ground
9	C _{IN}	INPUT C
10	C _{OUT}	Channel C Output
11	\bar{C}_{OUT}	Channel C Output
12	\bar{EN}	ENABLE
13	\bar{D}_{OUT}	Channel D Output
14	D _{OUT}	Channel D Output
15	D _{IN}	INPUT D
16	V _{CC}	Supply Voltage

Table 2. Truth table

Enable	Enable	Input	Output	Output
L	H	X	Z	Z
All other combinations of enable inputs		L	L	H
		H	H	L

Note: *L = Low Voltage State*
H = High Logic State
X = Don't Care
Z = High Impedance

2 Maximum ratings

Table 3. Absolute maximum ratings (Note 1, Note 2)

Symbol	Parameter	Value	Unit
V_{CC}	Supply voltage	-0.5 to 7	V
V_{IN}	DC Input voltage	-0.5 to ($V_{CC} + 0.5$)	V
V_{OUT}	DC Output voltage (high or low state)	-0.5 to 7	V
I_{IK}	Clamp diode current	± 20	mA
I_{OUT}	DC Output current per pin	± 150	mA
I_{CC}	DC V_{CC} or gnd current	± 150	mA
T_{STG}	Storage temperature range	-65 to +150	$^{\circ}\text{C}$

- Note: 1 Absolute Maximum Ratings are those values beyond which the safety of the device cannot be guaranteed. They are not meant to imply that the device should be operated at these limits. The table of electrical characteristics provide conditions for actual device operation.
- 2 Unless otherwise specified, all voltage are referenced to ground. All currents into the device pins are positive; all currents out of the device pins are negative.

Table 4. Recommended operating conditions

Symbol	Parameter	Value	Unit
V_{CC}	Supply voltage	4.5 to 5.5	V
V_{IN}	DC Input voltage	0 to V_{CC}	V
V_{OUT}	DC Output voltage (high or low state)	0 to V_{CC}	V
V_{OUT}	DC Output voltage ($V_{CC} = 0\text{V}$ or high impedance)	0 to 5	V
T_A	Operating temperature range	-40 to +85	$^{\circ}\text{C}$
t_r, t_f	Maximum enable input rise or fall times	500	ns

3 Electrical characteristics

Table 5. Electrical characteristics ($V_{CC} = 5V \pm 10\%$, unless otherwise specified, See [Note 1](#))

Symbol	Parameter	Test Conditions	Value			Unit	
			Min.	Typ.	Max.		
V_{IH}	High level input voltage		2			V	
V_{IL}	Low level input voltage				0.8	V	
V_{OH}	High level output voltage	$V_{IN} = V_{IH}$ or V_{IL} , $I_{OUT} = -20mA$	2.5	3.4		V	
V_{OL}	Low level output voltage	$V_{IN} = V_{IH}$ or V_{IL} , $I_{OUT} = +20mA$		0.3	0.5	V	
V_T	Differential output voltage	$R_L = 100 \Omega$ (Note 2)	2	3.1		V	
$V_T - \bar{V}_T$	Difference in differential output voltage	$R_L = 100 \Omega$ (Note 2)			0.4	V	
V_{OS}	Common mode output voltage	$R_L = 100 \Omega$ (Note 2)		1.8	3	V	
$V_{OS} - \bar{V}_{OS}$	Difference in common mode output voltage	$R_L = 100 \Omega$ (Note 2)			0.4	V	
I_{IN}	Input current	$V_{IN} = V_{CC}$, GND, V_{IH} or V_{IL}			± 1	μA	
I_{CC}	Quiescent supply current (Note 2)	$I_{OUT} = 0 \mu A$	$V_{IN} = V_{CC}$ or GND		200	500	μA
			$V_{IN} = 2.4$ or 0.5 V (Note 3)		0.8	2	mA
I_{OZ}	3-STATE output leakage current	$V_{OUT} = V_{CC}$ or GND $ENABLE = V_{IL}$ $\bar{ENABLE} = V_{IH}$		± 0.5	± 5	μA	
I_{SC}	Output short circuit current	$V_{IN} = V_{CC}$ or GND (Note 2 , Note 4)	-30		-150	mA	
I_{OFF}	Power off output leakage current (Note 2)	$V_{CC} = 0$ V	$V_{OUT} = 6$ V		100	μA	
			$V_{OUT} = -0.25$ V		-100	μA	

Note: 1 Unless otherwise specified, min/max limits apply across the recommended operating temperature range. All typical are given for $V_{CC} = 5V$ and $T_a = 25^\circ C$

2 See EIA Specification RS422 for exact test conditions.

3 Measured per pin input. All other input at V_{CC} or GND.

4 This is the current sourced when a high output is shorted to ground. Only one output at time should be shorted.

Table 6. Switching characteristics ($V_{CC} = 5V \pm 10\%$, $t_r = t_f \leq 6ns$, See [Note 1](#))

Symbol	Parameter	Test Conditions	Value			Unit
			Min.	Typ.	Max.	
t_{PLH} t_{PHL}	Propagation delay input to output	S1 Open	2	6	11	ns
Skew	(Note 2)	S1 Open		0.5	2	ns
t_{TLH} t_{THL}	Differential output rise and fall times	S1 Open		6	10	ns
t_{PZH}	Output enable time	S1 Closed		11	19	ns
t_{PZL}	Output enable time	S1 Closed		13	21	ns
t_{PHZ}	Output disable time (Note 3)	S1 Closed		5	9	ns
t_{PLZ}	Output disable time (Note 3)	S1 Closed		7	11	ns
C_{PD}	Power dissipation capacitance (Note 4)			50		pF
C_{IN}	Input capacitance			6		pF

- Note: 1 Unless otherwise specified, min/max limits apply across the recommended operating temperature range. All typical are given for $V_{CC}=5V$ and $T_a = 25^\circ C$
- 2 Skewis defined as the difference in propagation delays between complementary outputs at the 50% point.
- 3 Output disable time is the delay from the control input being switched to the output transistors tuning off. The actual disable times are less than indicated due to the delay added by RC time constant of the load.
- 4 CPD determines the no load dynamic power consumption, $P_D = C_{PD}V_{CC}^2 f = I_{CC}V_{CC}$, and the no load dynamic current consumption, $P_D = C_{PD} V_{CC}f + I_{CC}$.

4 Package mechanical data

In order to meet environmental requirements, ST offers these devices in ECOPACK® packages. These packages have a Lead-free second level interconnect. The category of second level interconnect is marked on the package and on the inner box label, in compliance with JEDEC Standard JESD97. The maximum ratings related to soldering conditions are also marked on the inner box label. ECOPACK is an ST trademark. ECOPACK specifications are available at: www.st.com

Plastic DIP-16 (0.25) MECHANICAL DATA

DIM.	mm.			inch		
	MIN.	TYP	MAX.	MIN.	TYP.	MAX.
a1	0.51			0.020		
B	0.77		1.65	0.030		0.065
b		0.5			0.020	
b1		0.25			0.010	
D			20			0.787
E		8.5			0.335	
e		2.54			0.100	
e3		17.78			0.700	
F			7.1			0.280
I			5.1			0.201
L		3.3			0.130	
Z			1.27			0.050

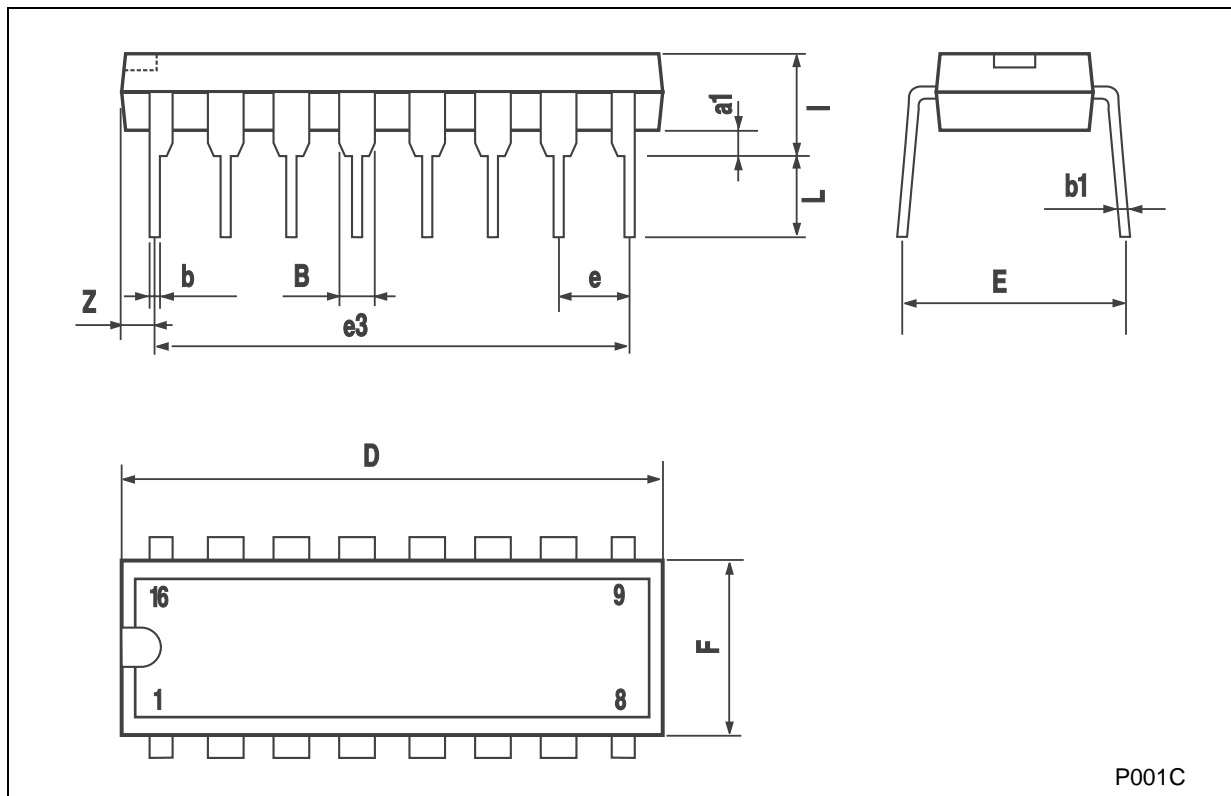

SO-16 MECHANICAL DATA

DIM.	mm.			inch		
	MIN.	TYP	MAX.	MIN.	TYP.	MAX.
A			1.75			0.068
a1	0.1		0.25	0.004		0.010
a2			1.64			0.063
b	0.35		0.46	0.013		0.018
b1	0.19		0.25	0.007		0.010
C		0.5			0.019	
c1	45° (typ.)					
D	9.8		10	0.385		0.393
E	5.8		6.2	0.228		0.244
e		1.27			0.050	
e3		8.89			0.350	
F	3.8		4.0	0.149		0.157
G	4.6		5.3	0.181		0.208
L	0.5		1.27	0.019		0.050
M			0.62			0.024
S	8° (max.)					

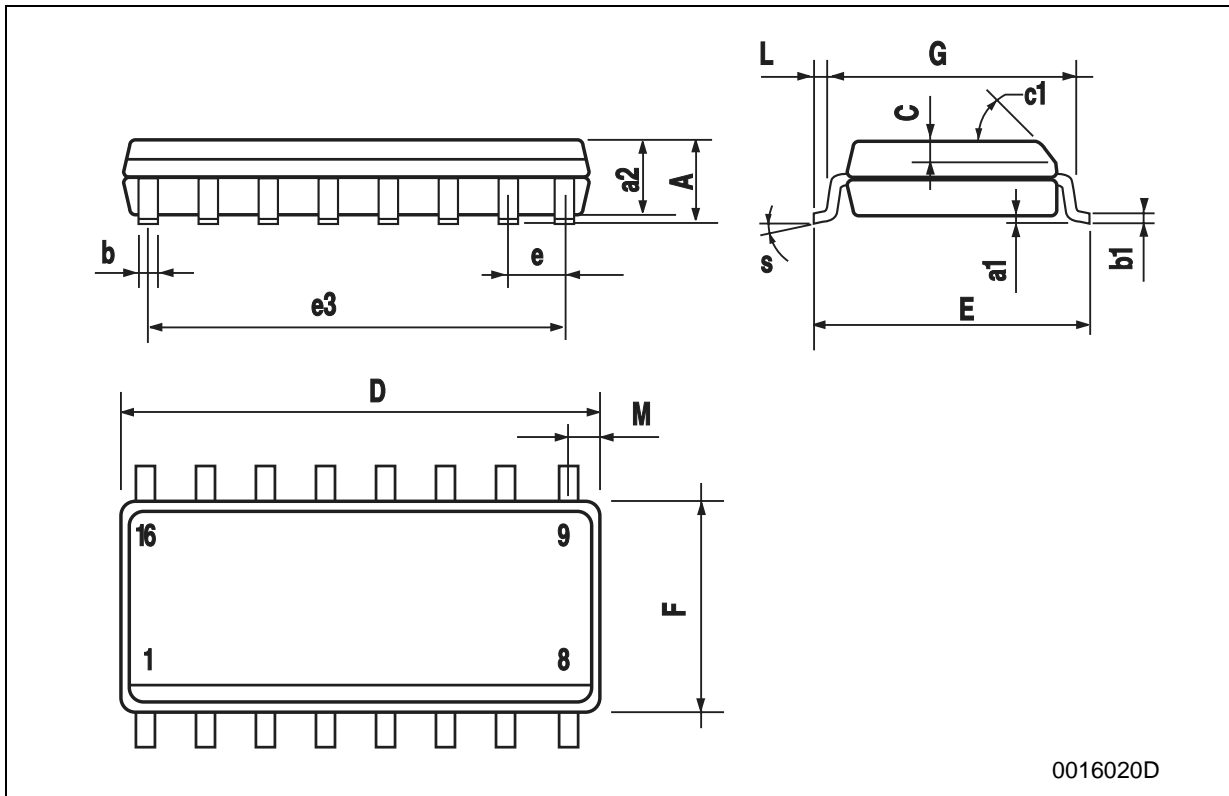

TSSOP16 MECHANICAL DATA

DIM.	mm.			inch		
	MIN.	TYP	MAX.	MIN.	TYP.	MAX.
A			1.2			0.047
A1	0.05		0.15	0.002	0.004	0.006
A2	0.8	1	1.05	0.031	0.039	0.041
b	0.19		0.30	0.007		0.012
c	0.09		0.20	0.004		0.0079
D	4.9	5	5.1	0.193	0.197	0.201
E	6.2	6.4	6.6	0.244	0.252	0.260
E1	4.3	4.4	4.48	0.169	0.173	0.176
e		0.65 BSC			0.0256 BSC	
K	0°		8°	0°		8°
L	0.45	0.60	0.75	0.018	0.024	0.030

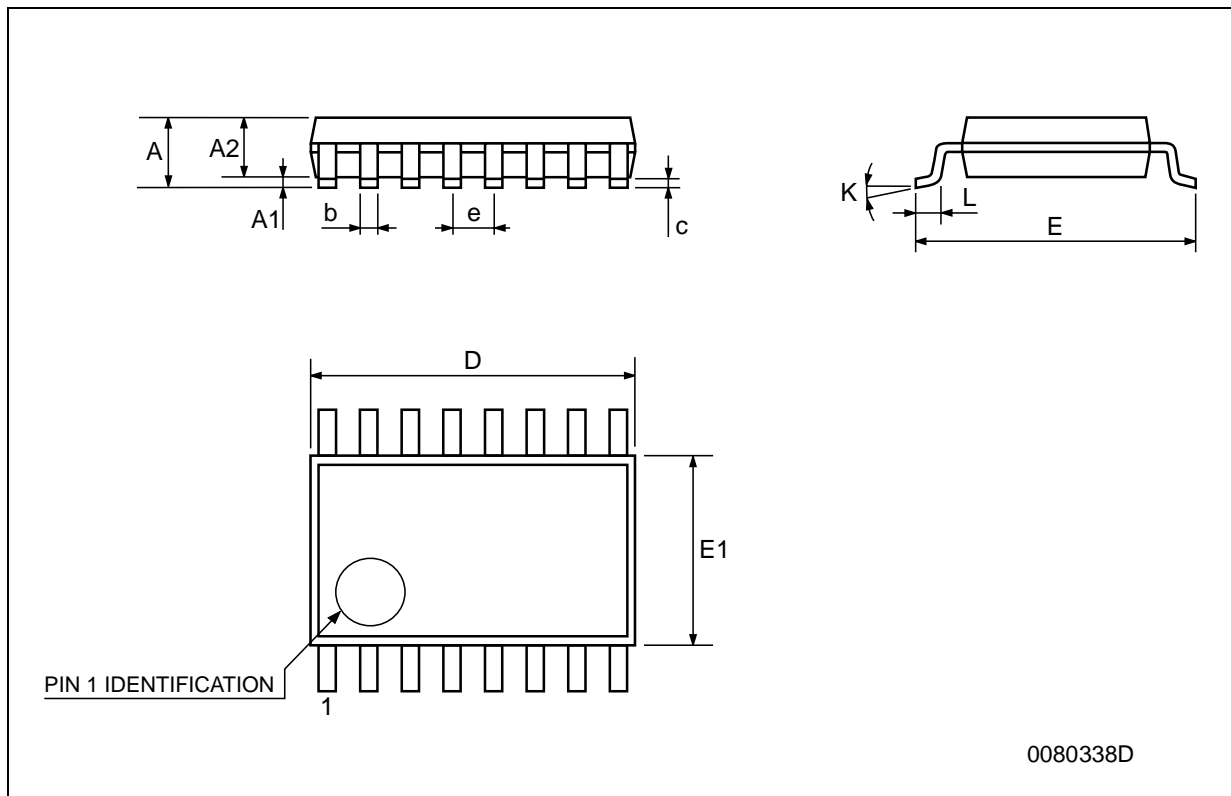

Tape & Reel SO-16 MECHANICAL DATA

DIM.	mm.			inch		
	MIN.	TYP	MAX.	MIN.	TYP.	MAX.
A			330			12.992
C	12.8		13.2	0.504		0.519
D	20.2			0.795		
N	60			2.362		
T			22.4			0.882
Ao	6.45		6.65	0.254		0.262
Bo	10.3		10.5	0.406		0.414
Ko	2.1		2.3	0.082		0.090
Po	3.9		4.1	0.153		0.161
P	7.9		8.1	0.311		0.319

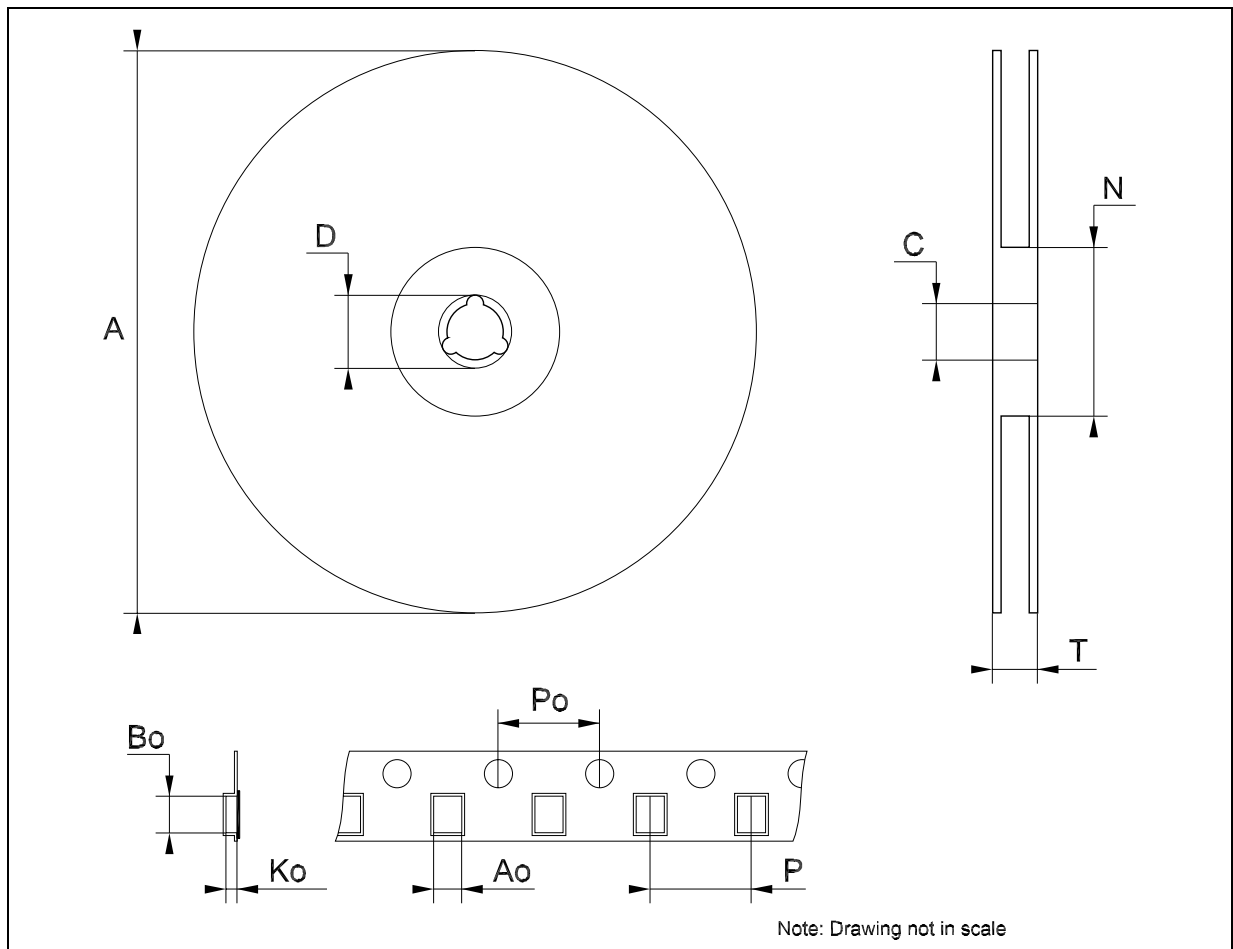

Tape & Reel TSSOP16 MECHANICAL DATA

DIM.	mm.			inch		
	MIN.	TYP	MAX.	MIN.	TYP.	MAX.
A			330			12.992
C	12.8		13.2	0.504		0.519
D	20.2			0.795		
N	60			2.362		
T			22.4			0.882
Ao	6.7		6.9	0.264		0.272
Bo	5.3		5.5	0.209		0.217
Ko	1.6		1.8	0.063		0.071
Po	3.9		4.1	0.153		0.161
P	7.9		8.1	0.311		0.319

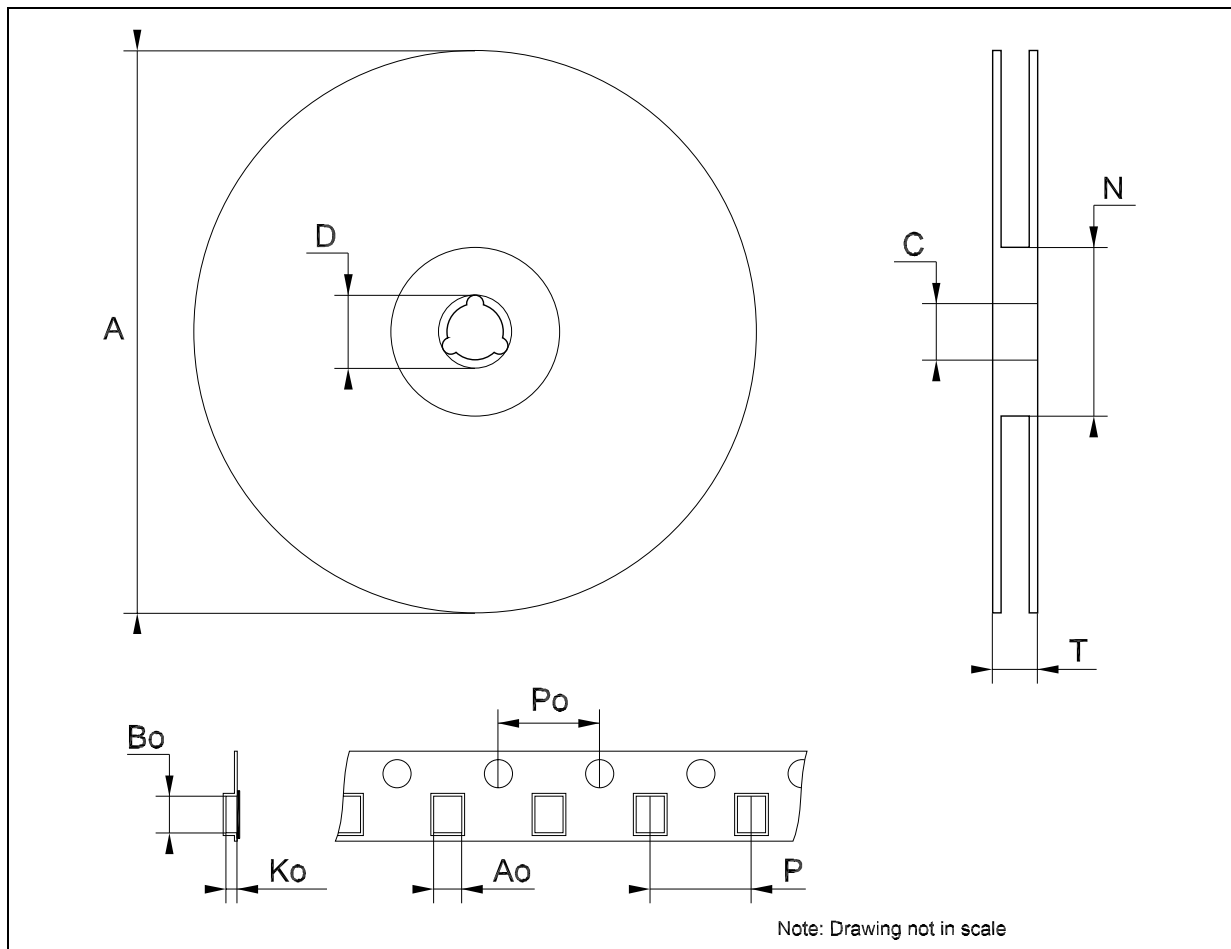

5 Revision history

Table 7. Revision history

Date	Revision	Changes
02-May-2006	7	Order codes has been updated and new template.

Please Read Carefully:

Information in this document is provided solely in connection with ST products. STMicroelectronics NV and its subsidiaries ("ST") reserve the right to make changes, corrections, modifications or improvements, to this document, and the products and services described herein at any time, without notice.

All ST products are sold pursuant to ST's terms and conditions of sale.

Purchasers are solely responsible for the choice, selection and use of the ST products and services described herein, and ST assumes no liability whatsoever relating to the choice, selection or use of the ST products and services described herein.

No license, express or implied, by estoppel or otherwise, to any intellectual property rights is granted under this document. If any part of this document refers to any third party products or services it shall not be deemed a license grant by ST for the use of such third party products or services, or any intellectual property contained therein or considered as a warranty covering the use in any manner whatsoever of such third party products or services or any intellectual property contained therein.

UNLESS OTHERWISE SET FORTH IN ST'S TERMS AND CONDITIONS OF SALE ST DISCLAIMS ANY EXPRESS OR IMPLIED WARRANTY WITH RESPECT TO THE USE AND/OR SALE OF ST PRODUCTS INCLUDING WITHOUT LIMITATION IMPLIED WARRANTIES OF MERCHANTABILITY, FITNESS FOR A PARTICULAR PURPOSE (AND THEIR EQUIVALENTS UNDER THE LAWS OF ANY JURISDICTION), OR INFRINGEMENT OF ANY PATENT, COPYRIGHT OR OTHER INTELLECTUAL PROPERTY RIGHT.

UNLESS EXPRESSLY APPROVED IN WRITING BY AN AUTHORIZED REPRESENTATIVE OF ST, ST PRODUCTS ARE NOT DESIGNED, AUTHORIZED OR WARRANTED FOR USE IN MILITARY, AIR CRAFT, SPACE, LIFE SAVING, OR LIFE SUSTAINING APPLICATIONS, NOR IN PRODUCTS OR SYSTEMS, WHERE FAILURE OR MALFUNCTION MAY RESULT IN PERSONAL INJURY, DEATH, OR SEVERE PROPERTY OR ENVIRONMENTAL DAMAGE.

Resale of ST products with provisions different from the statements and/or technical features set forth in this document shall immediately void any warranty granted by ST for the ST product or service described herein and shall not create or extend in any manner whatsoever, any liability of ST.

ST and the ST logo are trademarks or registered trademarks of ST in various countries.

Information in this document supersedes and replaces all information previously supplied.

The ST logo is a registered trademark of STMicroelectronics. All other names are the property of their respective owners.

© 2006 STMicroelectronics - All rights reserved

STMicroelectronics group of companies

Australia - Belgium - Brazil - Canada - China - Czech Republic - Finland - France - Germany - Hong Kong - India - Israel - Italy - Japan - Malaysia - Malta - Morocco - Singapore - Spain - Sweden - Switzerland - United Kingdom - United States of America

www.st.com