

## Mono and Colour Digital Video CMOS Image Sensors

### DESCRIPTION

VV5404 and VV6404 are highly integrated CMOS VLSI sensors which enables high standards of performance and image quality at a very cost-effective price point. The 356 x 292 monochrome device offers one of the simplest routes currently available to design-in of imaging applications, while the colour device is ideal for low cost PC camera applications.

Both devices incorporate a comprehensive range of on-board controls eliminating the need for additional support chips. On-chip A/D conversion provides 8 bit digital output and the device set up is fully automatic via the built-in automatic black level calibration algorithm.

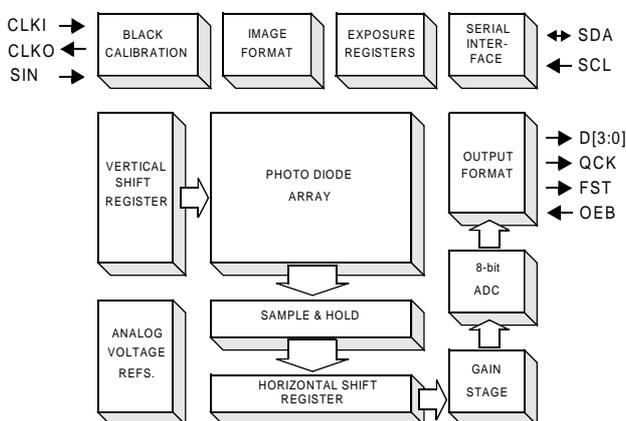
Exposure and gain settings are programmable and operation is controlled via a serial interface.

This sensors offer variable frame rates of up to 30 frames per second and a 4 wire digital video bus. The digital interface also provides a tri-stateable data qualification clock and frame synchronisation signal.

Hand-held products, in applications such as PDAs, bar code scanning or automatic meter reading, will benefit from the low power requirements and from the inbuilt sleep and power down modes.

The price and performance standards introduced with the VV5404 and VV6404 enable use of an imaging solution where previously it may not have been practicable on cost grounds.

### BLOCK DIAGRAM



### FEATURES

- CIF Format mono or colour pixel array
- Up to 30 frames per second operation
- On-chip 8 bit analogue to digital converter
- Low power consumption
- Up to 356 x 292 pixel image size
- Automatic exposure and gain control
- Serial interface control
- Programmable exposure and gain values
- Automatic black level calibration
- 4-wire digital video bus
- Evaluation kit available

### APPLICATIONS

- PC Cameras
- Biometrics
- Inspection Systems

### SPECIFICATIONS

<b>Pixel resolution</b>	356 x 292 (CIF)
<b>Array size</b>	4.272mm x 3.212mm
<b>Pixel size</b>	12.0 $\mu\text{m}$ x 11.0 $\mu\text{m}$
<b>Min. illumination</b>	0.1 lux
<b>Exposure control</b>	Automatic (to 25000:1)
<b>Gain control</b>	Automatic (to +20dB)
<b>Signal/Noise ratio</b>	46dB
<b>Supply voltage</b>	5.0v DC +/- 5%
<b>Supply current</b>	<75mA
<b>Operating temperature (ambient)</b>	0°C - 40°C (for extended temp. info please contact STMicroelectronics)
<b>Package type</b>	48LCC

### Important:

1. A colour co-processor is required to convert the VV6404 sensor's video data stream of raw colourised pixel data into either a CIF or QCIF format RGB or YUV colour image.
2. VV5404 and VV6404 do NOT have any form of automatic exposure control. This must be performed externally.

## Table of Contents

<b>1. Introduction</b> .....	<b>4</b>
<b>2. Operating Modes</b> .....	<b>6</b>
2.1 Image Read-out Options.....	6
2.2 Frame Rate Options .....	6
<b>3. Exposure Control</b> .....	<b>8</b>
<b>4. Digital Video Interface Format</b> .....	<b>9</b>
4.1 General description.....	9
4.2 Embedded control data.....	9
4.2.1 The combined escape and sync character .....	9
4.2.2 The command word.....	9
4.2.3 Supplementary Data.....	13
4.3 Video timing reference and status/configuration data.....	13
4.3.1 Blank lines .....	14
4.3.2 Black line timing.....	14
4.3.3 Valid video line timing .....	14
4.3.4 Start of frame line timing .....	14
4.3.5 End of frame line timing.....	14
4.4 Detection of sensor using data bus state .....	14
4.5 Resetting the Sensor Via the Serial Interface.....	14
4.6 Power-up, Low-power and Sleep modes .....	14
4.6.1 Power-Up/Down (Figure 12) .....	18
4.6.2 Low-Power Mode (Figure 10) .....	18
4.6.3 Sleep Mode (Figure 11).....	18
4.6.4 Application of the system clock during sensor low-power modes .....	22
4.7 Qualification of Output Data .....	22
4.7.1 Using the External Clock signal applied to CKI .....	22
4.7.2 Data Qualification Clock, QCK.....	22
4.7.3 Frame Start Signal, FST .....	22
<b>5. Serial Control Bus</b> .....	<b>27</b>
5.1 General Description .....	27
5.2 Serial Communication Protocol .....	27
5.3 Data Format.....	27
5.4 Message Interpretation.....	28
5.5 The Programmers Model .....	29
5.5.1 DeviceH [000_00002] and DeviceL [000_00012].....	31
5.5.2 Status0 [000_00102] .....	31
5.5.3 Line_count_H [000_00112] & Line_count_L [000_01002].....	31
5.5.4 Setup0 [001_00002] .....	32
5.5.5 Setup1 [001_00012] .....	32
5.5.6 Setup2 [001_00102] .....	33
5.5.7 Setup4 [001_01002] .....	33
5.5.8 Setup5 [001_01012] .....	34
5.5.9 Exposure Control Registers [010_00002] - [010_10012].....	35
5.5.10 ADC Setup Register AS0 [111_01112] .....	37
5.6 Types of messages.....	38
5.6.1 Single location, single data write.....	38

---

5.6.2 Single location, single data read..	38
5.6.3 No data write followed by same location read.	38
5.6.4 Same location multiple data write..	39
5.6.5 Same location multiple data read	39
5.6.6 Multiple location write	40
5.6.7 Multiple location read.	40
5.7 Serial Interface Timing	41
<b>6. Clock Signal</b>	<b>42</b>
6.8 Synchronising 2 or More Cameras	43
<b>7. Detailed specifications.</b>	<b>45</b>
7.1 General	45
7.2 DC characteristics.	45
<b>8. Physical</b>	<b>46</b>
8.1 Pinout Diagram	46
8.2 Signal Names	47
8.3 48LCC Mechanical Dimensions	49
8.4 VV6404 Sensor Support Circuit Schematic Diagram	50
8.5 Sensor Support Circuit Component List	50
<b>9. Ordering Information</b>	<b>52</b>

## 1. Introduction

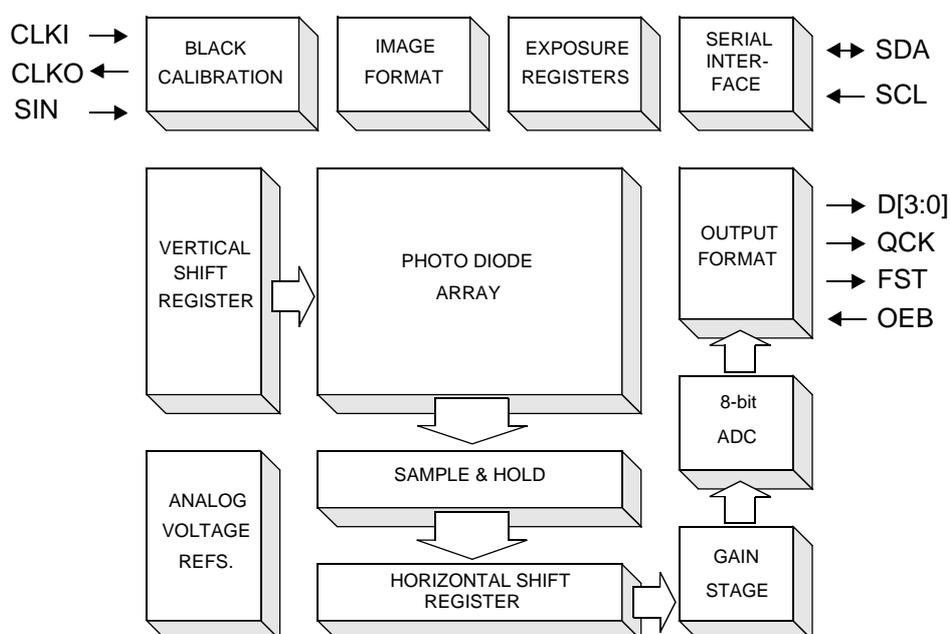
VV5404 and VV6404 are CIF format CMOS image sensors capable of outputting digital pixel data at frame rates, of upto 30 frames per second. The VV5404 is a monochrome part, while the VV6404 has a colour filter applied over the sensor array.

**Important:** The VV6404 sensor's video data stream only contains raw colourised pixel data. A colour co-processor is required to generate for example either a CIF or a QCIF format YUV colour image.

The 356 x 292 pixel sensors have an on-chip 8-bit analogue to digital converter (Figure 1). The sensors offer very flexible digital interface, the main components of which are listed below:

1. A tri-stateable 4-wire data bus (D[3:0]) for sending both video data and embedded timing references.
2. A data qualification clock, QCK, which can be programmable via the serial interface to behave in a number of different ways (Tri-stateable).
3. A frame start signal, FST (Tri-stateable).
4. A 2-wire serial interface (SDA,SCL) for controlling and setting up the device.
5. The ability to synchronise the operation of multiple cameras - synchronisation input, SIN.

An 8-bit pixel value is transmitted across the 4 wire tri-stateable databus as series pair of 4-bit nibbles, most significant nibble first. Along within the pixel data, codes representing the start and end frames and the start and end of lines are embedded within the video data stream to allow the video processor to synchronise with video data the camera module is generating. Section 4. defines the format for the output video datastream.



**Figure 1 : Block Diagram of VV5404 and VV6404 Image Sensors**

To complement the embedded control sequences a data qualification clock, QCK, and a frame start signal are also available. QCK can be set-up to either be:

1. Disabled
2. Free-running.
3. Qualify only the control sequences and the pixel data.
4. Qualify the pixel data only

There is also the choice of two different QCK frequencies, where one is twice the frequency of the other.

1. Fast QCK: the falling edge of the clock qualifies the nibble data irrespective of whether it is the most or the least significant nibble.
2. Slow QCK: the rising edge of the clock qualifies the most significant nibbles while the falling edge of the clock qualifies the least significant nibbles.

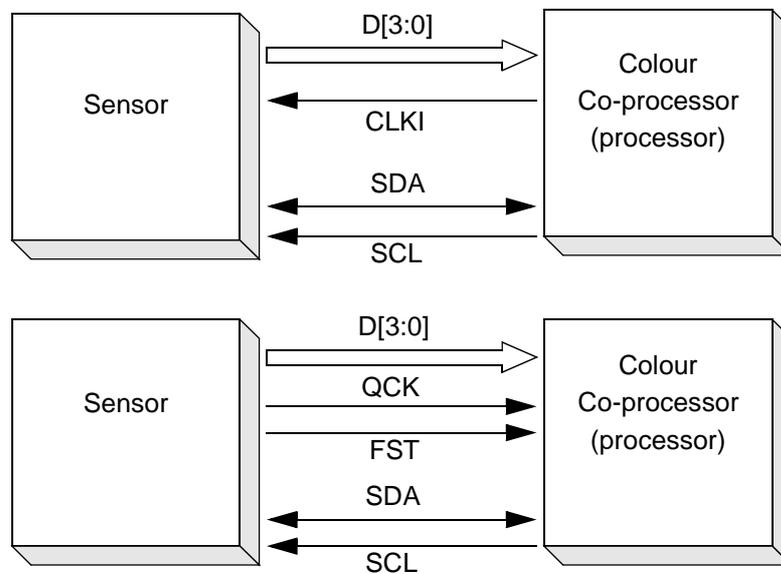
The FST can be enabled/disabled via the serial interface.

OEB tri-states all 4 databus lines, D[3:0], the qualification clock, QCK and the frame start signal, FST.

There are 3 main ways of interfacing to the VV5404 or VV6404 sensor based on the above signals:

1. The processor capturing the data (or colour co-processor for VV6404) supplies the sensor clock, CKI, and uses the embedded control sequences to synchronise with the frame and line level timings. Thus the processor and sensor are running off derivatives of the same fundamental clock (4 fsc - 14.31818 MHz). To allow the receiver to determine the best sampling position of the video data, during its power-up sequence the sensor outputs a 101010... sequence on each of its databus lines for the video processor to lock on to.
2. The video processor uses a free-running QCK supplied by the sensor to sample the incoming video data stream. The embedded control sequences are used to synchronise the frame and line level timings. A crystal is used to generate the clock for the sensor.
3. The video processor uses FST and the data only mode for QCK to synchronise to the incoming video data. Primarily intended for interfacing to frame grabbers.

The 2-wire serial interface provides complete control over how the sensor is setup and run. Exposure and gain values are programmed via this interface. Section 5. defines the communications protocol and the register map of all the locations which can be accessed via the serial interface.



**Figure 2 : Interfacing Options**

Using the first two interface options outlined above it is possible to control the sensor and receive video data via a 9-wire cable between the sensor and the video processor/colour-processor.

1. A 4-wire data bus (D[3:0]) for sending both video data and embedded timing references.
2. A 2-wire serial interface (SDA,SCL).
3. The clock for the sensor or QCK from the sensor.
4. VCC and GND power lines.

The various image read-out and frame rate options are detailed in Sections 2 and 3 respectively.

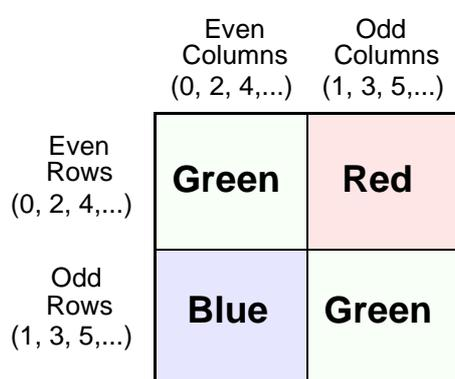
## 2. Operating Modes

### 2.1 Image Read-out Options

The output image format is CIF (352 x 288 pixel array). To provide the colour co-processor with the extra information it needs for interpolation at the edges of the VV6404 pixel array, an optional border 2 pixels deep on all 4 sides of the array can be enabled (Figure 4). The resulting image size of 356 x 292 pixels is the default power up state for this camera module. The border option is programmable via the serial interface.

Border	Image size (column x row)	
Disabled	352 x 288	
Enabled	356 x 292	Default

**Table 1 : Image Format Selection.**



**Figure 3 : Bayer Colourisation Pattern. (VV6404 only)**

Image read-out is either non-interlaced raster scan, or 'shuffled' non-interlaced raster scan.

The shuffled raster scan order differs from a conventional raster in that the pixels of individual rows are re-ordered, with the odd pixels within a row read-out first, followed by the even pixels.

This 'shuffled' read-out within a line, is useful in the VV6404 device as it groups pixels of the same colour (according to the Bayer pattern - Figure 3) together, reducing cross talk between the colour channels.

**NOTE:** This option is on by default in both VV5404 and VV6404 sensors and is controllable via the serial interface.

### 2.2 Frame Rate Options

Two options: 30 fps or 25 fps (Assuming a 7.15909 MHz input clock and the default clock divider setting). The number of video lines in for each frame rate is the same (304), the slower frame rate is implemented by extending the line period from 393 pixel periods to 471 pixel periods. 30 fps is the default option, the frame rate is programmable via the serial interface.

Frame Rate (fps)	Frame Timing (Pixels x Lines)	
25	471 x 304	
30	393 x 304	default

**Table 2 : Frame Rate Selection**

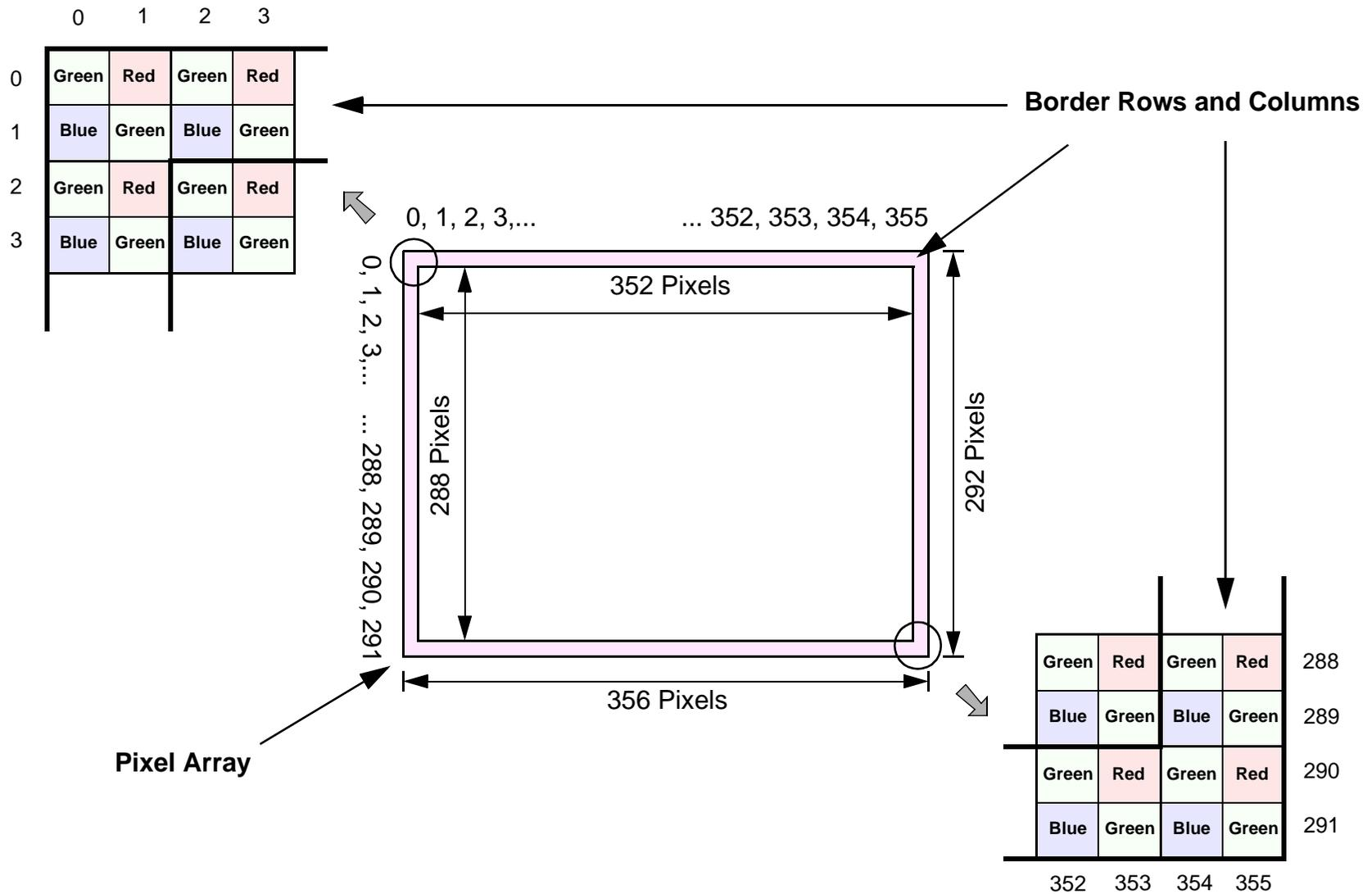


Figure 4 : VV6404 Coloured Image Format

### 3. Exposure Control

The exposure time for a pixel and the gain of the input amplifier to the 8-bit ADC are programmable via the serial interface. The explanation below assumes that the gain and exposure values are updated together as part of a 5 byte serial interface auto-increment sequence.

The exposure is divided into 2 components - coarse and fine. The coarse exposure value sets the number of lines a pixel exposes for, while the fine exposure sets the number of additional pixel clock cycles a pixel integrates for. The sum of the two gives the overall exposure time for the pixel array.

30 fps mode: Exposure Time = (Clock Divisor) x (Coarse x 393 + Fine) x (CKI clock period)/

25 fps mode: Exposure Time = (Clock Divisor) x (Coarse x 471 + Fine) x (CKI clock period)

Value	Units	30 fps mode		25 fps mode	
		Min.	Max.	Min.	Max.
Coarse	Video Lines	0	302	0	302
Fine	Pixel Clocks	0	356	0	434

**Table 3 : Coarse and Fine Exposure Ranges.**

If an exposure value is loaded outwith the valid ranges listed in the above table the value is clipped to lie within the above ranges.

Gain Code, G[2:0]			Amplifier Gain
0	0	0	1
0	0	1	2
0	1	1	4
1	1	1	8

**Table 4 : Main Gain Steps.**

Exposure and gain values are re-timed within the sensor to ensure that a new set of values is only applied to the sensor array at the start of each frame. Bit 0 of the Status Register is set high when a new exposure value is written via the serial interface but has not yet been applied to the sensor array.

There is a 1 frame latency between a new exposure value being applied to the sensor array and the results of the new exposure value being read-out. The same latency does not exist for the gain value. To ensure that the new exposure and gain values are aligned up correctly the sensor delays the application of the new gain value by one frame relative to the application of the new exposure value.

To eliminate the possibility of the sensor array seeing only part of the new exposure and gain setting, if the serial interface communications extends over a frame boundary, the internal re-timing of exposure and gain data is disabled while writing data to any location in the Exposure page of the serial interface register map. Thus if the 5 bytes of exposure and gain data is sent as an auto-increment sequence, it is not possible for the sensor to consume only part of the new exposure and gain data.

## 4. Digital Video Interface Format

### 4.1 General description

The video interface consists of a unidirectional, tri-stateable 4-wire databus. The nibble transmission is synchronised to the rising edge of the system clock (Figure 13).

Read-out Order	Progressive Scan (Non-interlaced)
Form of encoding	Uniformly quantised, PCM, 8 bits per sample
Correspondence between video signal levels and quantisation levels:	Internally valid pixel data is clipped to ensure that 00 <sub>H</sub> and FF <sub>H</sub> values do not occur when pixel data is being output on the data bus. This gives 254 possible values for each pixel (1 - 254). The video black level corresponds to code 16.

**Table 5 : Video encoding parameters**

Digital video data is 8 bits per sample, transmitted as serial pairs of parallel 4-bit nibbles (most significant nibble first) on 4 wires.

Multiplexed with the sampled pixel data is control information including both video timing references and sensor status/configuration data. Video timing reference information takes the form of field start characters, line start characters, end of line characters and a line counter.

Where hexadecimal values are used, they are indicated by a subscript H, such as FF<sub>H</sub>; other values are decimal.

### 4.2 Embedded control data

To distinguish the control data from the sampled video data all control data is encapsulated in embedded control sequences. These are a minimum of 6 words long and includes a combined escape/sync character, 1 control word (the 'command byte') and 2 words of supplementary data.

To minimise the susceptibility of the embedded control data to random bit errors redundant coding techniques have been used to allow single bit errors in the embedded control words to be corrected. However, more serious corruption of control words or the corruption of escape/sync characters cannot be tolerated without loss of sync to the data stream. To ensure that a loss of sync is detected a simple set of rules has been devised. The four exceptions to the rules are outlined below:

1. Data containing a command words that has two bit errors.
2. Data containing two 'end of line' codes that are not separated by a 'start of line' code.
3. Data preceding an 'end of frame' code before a start of frame' code has been received.
4. Data containing line that do not have sequential line numbers (excluding the 'end of frame' line).

If the video processor detects one of these violations then it should abandon the current frame of video.

#### 4.2.1 The combined escape and sync character

Each embedded control sequence begins with a combined escape and sync character that is made up of three words. The first two of these are FF<sub>H</sub> FF<sub>H</sub>- constituting two words that are illegal in normal data. The next word is 00<sub>H</sub> - guaranteeing a clear signal transition that allows a video processor to determine the position of the word boundaries in the serial stream of nibbles. Combined escape and sync characters are always followed by a command word - making up the four word minimum embedded control sequence.

#### 4.2.2 The command word

The word that follows the combined escape/sync characters defines the type of embedded control data. Three of the 8 bits are used to carry the control information, four are 'parity bits' that allow the video processor to detect and correct a certain level of errors in the transmission of the command words, the remaining bit is always set to 1 to ensure that the command word is never has the value 00<sub>H</sub>. The coding scheme used allows the correction of single bit errors (in the 8-bit sequence) and the detection of 2 bit errors. The three data bits of the command word are interpreted as shown in Figure 5.

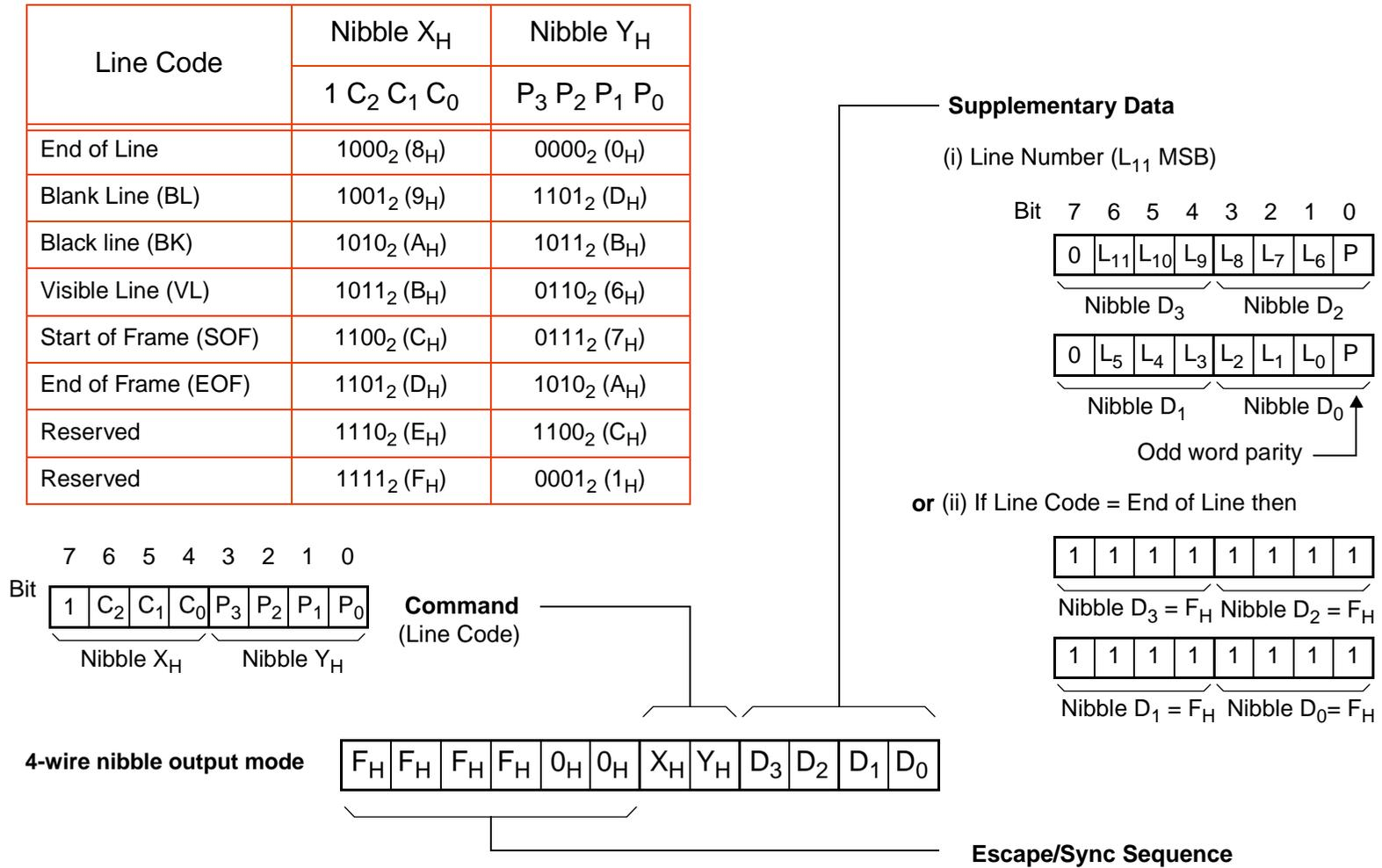
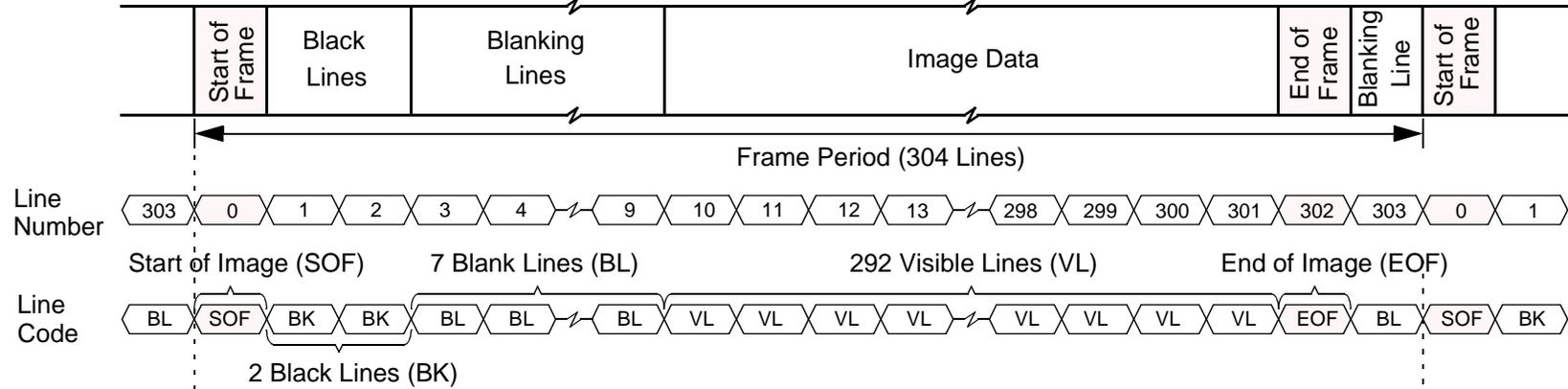
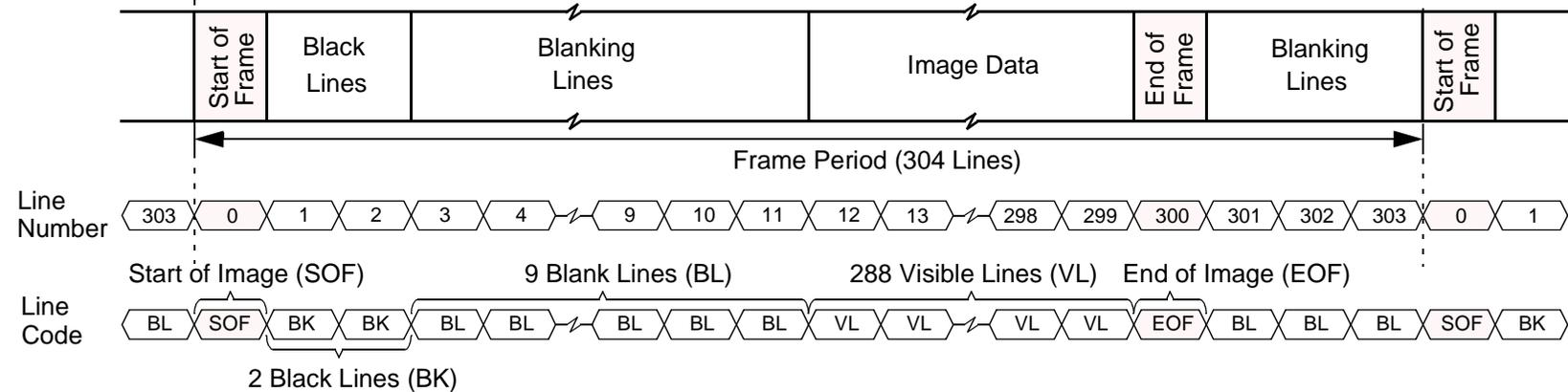
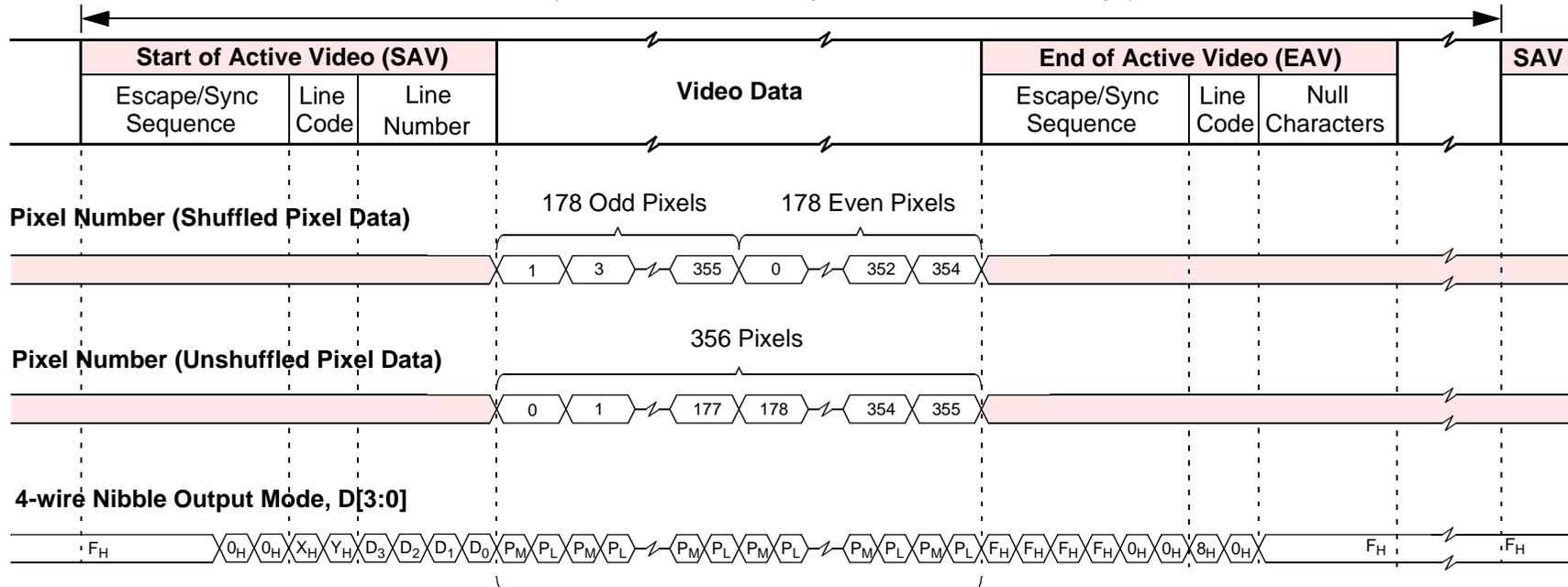


Figure 5 : Embedded Control Sequence

**Frame Format (Border rows and columns enabled - Default) :**

**Frame Format (Border rows and columns disabled) :**

**Figure 6 : Frame Formats**

### Line Format

Line Period (393 Pixel Periods - 30 fps, 471 Pixel Periods - 25 fps)



- (i) Blanking Line (BL)      P = Blanking Level (07<sub>H</sub>)
- (ii) Black Line (BK)      P = Valid Black Pixel Data
- (iii) Visible Line (VL)    P = Valid Pixel Data
- (iv) Start of Frame (SOF)   P = Sensor Status Data
- (v) End of Frame (EOF)    P = Blanking Level (07<sub>H</sub>)

P<sub>M</sub> = Pixel Value - Most Significant Nibble, P<sub>L</sub> = Pixel Value - Least Significant Nibble, P = 8-bit Pixel Value

**Figure 7 : Line Data Format.**

Parity Checks				Comment
P <sub>3</sub>	P <sub>2</sub>	P <sub>1</sub>	P <sub>0</sub>	
1	1	1	1	Code word un-corrupted
1	1	1	0	P <sub>0</sub> corrupted, line code OK
1	1	0	1	P <sub>1</sub> corrupted, line code OK
1	0	1	1	P <sub>2</sub> corrupted, line code OK
0	1	1	1	P <sub>3</sub> corrupted, line code OK
0	0	1	0	C <sub>0</sub> corrupted, invert sense of C <sub>0</sub>
0	1	0	0	C <sub>1</sub> corrupted, invert sense of C <sub>1</sub>
1	0	0	0	C <sub>2</sub> corrupted, invert sense of C <sub>2</sub>
All other codes				2-bit error in code word.

**Table 6 : Detection of 1-bit and 2-bit errors in the Command Word**

The even parity bits are based on the following relationships:

1. An even number of ones in the 4-bit sequence (C<sub>2</sub>, C<sub>1</sub>, C<sub>0</sub> and P<sub>0</sub>).
2. An even number of ones in the 3-bit sequence (C<sub>2</sub>, C<sub>1</sub>, P<sub>1</sub>).
3. An even number of ones in the 3-bit sequence (C<sub>2</sub>, C<sub>0</sub>, P<sub>2</sub>).
4. An even number of ones in the 3-bit sequence (C<sub>1</sub>, C<sub>0</sub>, P<sub>3</sub>).

Table 6 shows how the parity bits maybe used to detect and correct 1-bit errors and detect 2-bit errors.

#### 4.2.3 Supplementary Data

The last 2 bytes of the embedded control sequence contains supplementary data. This normally contains the current line number except if the line code is the end of line, the 2 bytes are padded out using null characters (FF<sub>H</sub>). The 12 bit line number is packaged up by splitting it into two 6-bit values. Each 6-bit values is then converted into an 8-bit value by adding a zero to the start and an odd word parity bit at the end.

#### 4.3 Video timing reference and status/configuration data

The video sequence is made up of lines of data. Each field of data is constructed of the following data lines:

1. A start of frame line
2. 2 of 'black lines' (used for black level calibration)
3. 7 (9) of blank lines
4. 292 (288) active video lines
5. An end of frame line
6. 1 (3) blank lines

The numbers given in ( ) are for when the border rows and columns are not output on the databus.

Each line of data starts with an embedded control sequence that identifies the line type (as outlined in Table 3). The control sequence is then followed by two bytes that, except in the case of the end-of-frame line, contain a coded line number. The line number sequences starts with the start-of-frame line at 00<sub>H</sub> and increments one per line up until the end-of-frame line. Each line is terminated with an end-of-line embedded control sequence. The line start embedded sequences must be used to recognise data lines as a number of null bytes may be inserted between data lines.

### 4.3.1 Blank lines

In addition to padding between data lines, actual blank data lines may appear in the positions indicated above. These lines begin with start-of-blank-line embedded control sequences and are constructed identically to active video lines except that they will contain only blank bytes (07<sub>H</sub>).

### 4.3.2 Black line timing

The black lines (which are used for black level calibration) are identical in structure to valid video lines except that they begin with a start-of-black line sequence and contain either information from the sensor 'black lines' or blank bytes (07<sub>H</sub>).

### 4.3.3 Valid video line timing

All valid video data is contained on active video lines. The pixel data appears as a continuous stream of bytes within the active lines. The pixel data may be separated from the line header and end-of-line control sequence by a number of 'blank' bytes (07<sub>H</sub>), e.g. when the border lines and pixels are disabled 07<sub>H</sub> is output in place of pixels 0, 1, 354 and 355.

### 4.3.4 Start of frame line timing

The start of frame line which begins each video field contains no video data but instead contains the contents of all the serial interface registers. This information follows the start-of-line header immediately and is terminated by an end-of-line control sequence. To ensure that no escape/sync characters appear in the sensor status/configuration information the code 07<sub>H</sub> is output after each serial interface value. Thus it takes 256 pixel clock periods (512 system clocks) to output all 128 of the serial interface registers. The remainder of the 356 pixel periods of the video portion of the line is padded out using 07<sub>H</sub> values. The first two pixel locations are also padded with 07<sub>H</sub> characters (Figure 8) If a serial interface register location is unused then 07<sub>H</sub> is output. The read-out order of the registers is independent of whether the pixel read-out order is shuffled or un-shuffled.

### 4.3.5 End of frame line timing

The end of frame line which begins each video field contains no video data. Its sole purpose is to indicate the end of a frame.

## 4.4 Detection of sensor using data bus state

The video processor device must have internal pull-down terminations on the data bus. On power-up a sensor will pull all data lines high for a guaranteed period. This scheme allows the presence of a sensor on the interface to be detected by the video processor on power-up, and the connection of a sensor to an already power-up interface (a 'hot' connection).

The absence of a sensor is detected by the video processor seeing more than 32 consecutive nibbles of 0<sub>H</sub> on the data bus. On detecting the absence of a sensor, CKI, should be disabled (held low).

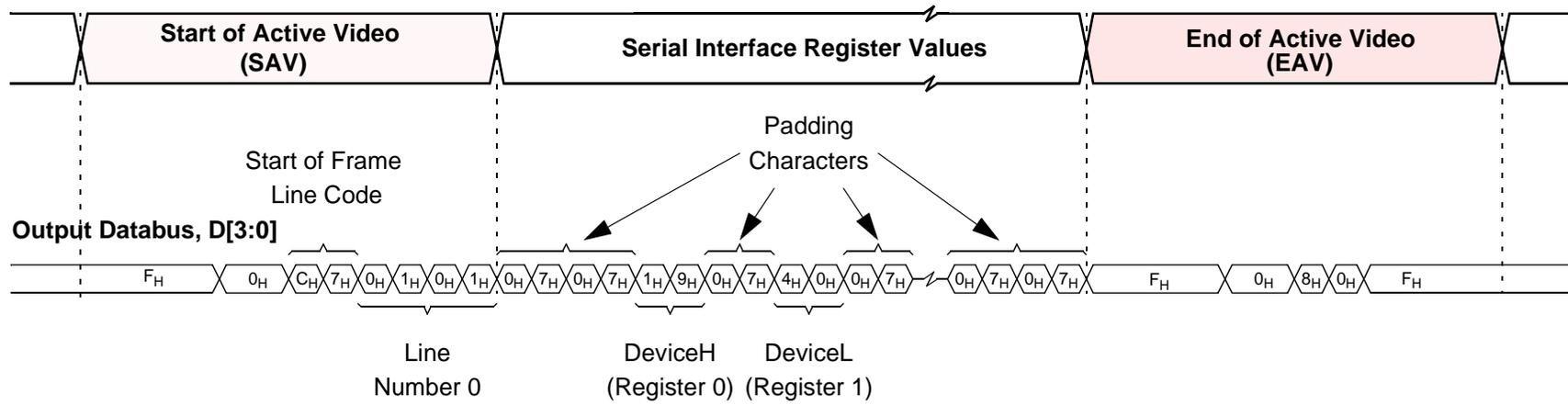
The presence of a sensor is detected by the video processor seeing more than 32 consecutive nibbles of F<sub>H</sub> on the data bus. On detecting the presence of a sensor, CKI, should be enabled.

## 4.5 Resetting the Sensor Via the Serial Interface

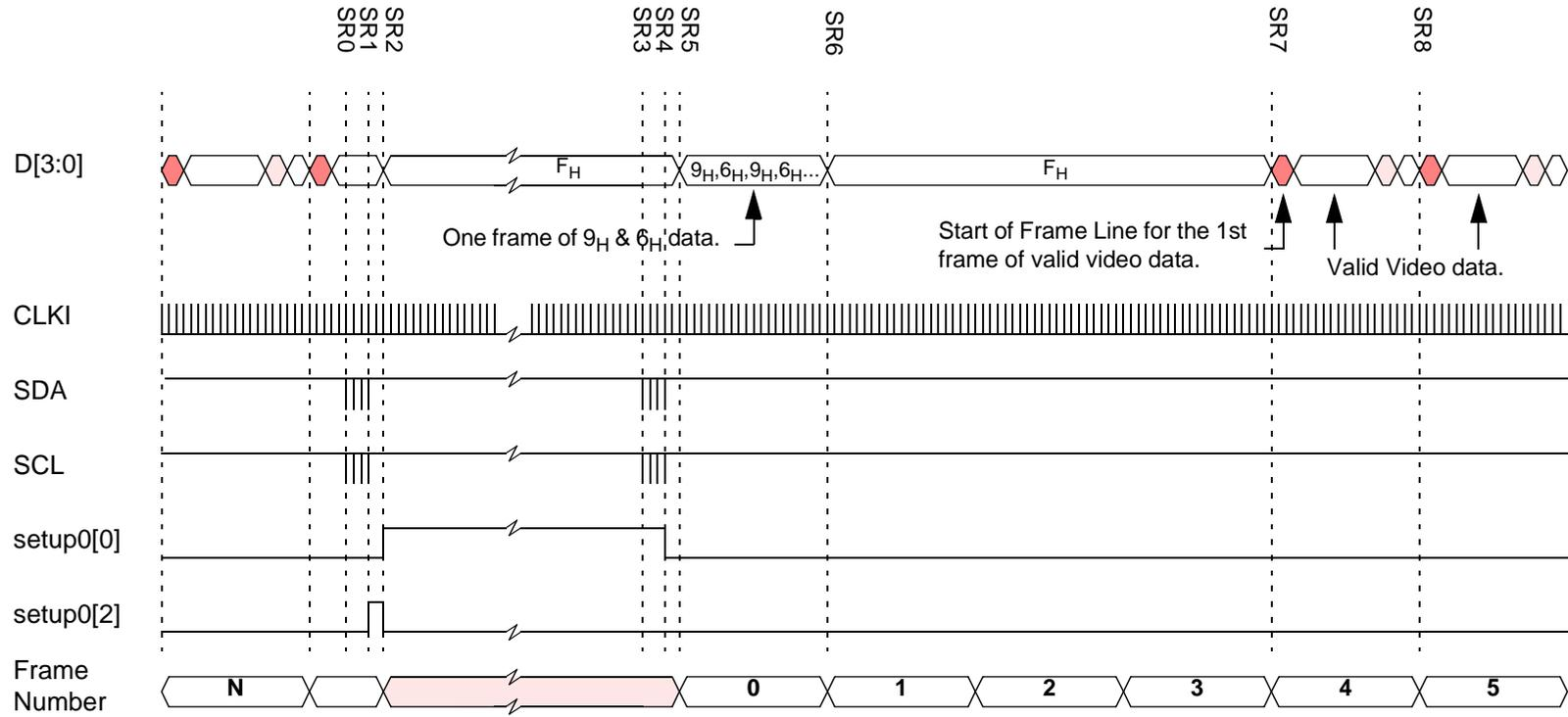
Bit 2 of setup register 0 allows the VV6404 sensor to be reset to its power-on state via the 2-wire serial interface. Setting this "Soft Reset" bit causes all of the serial interface registers including the "Soft Reset" bit to be reset to their default values. This "Soft Reset" leaves the sensor in low-power mode and thus an "Exit Low-Power Mode" command (Section 4.6.2) must be issued via the serial interface before the sensor will start to generate video data (Figure 9).

## 4.6 Power-up, Low-power and Sleep modes

To clarify the state of the interface on power-up and in the case of a 'hot' connection of the interface cable the power-up state of the bus is defined below.



**Figure 8 : Status Line Data Format.**



SR0-SR1	"Soft-Reset" Command. At the end of the command the sensor is reset and enters low-power mode.
SR2	The sensor enters low-power mode.
SR3-SR4	"Exit Low Power Mode" Command. Powers-up analogue circuits and initiates the VM6404 sensor's 4-frame start-up sequence
SR5-SR6	1 Frame of alternating 9 <sub>H</sub> & 6 <sub>H</sub> data on D[3:0] for the video processor to determine the best sampling phase for the nibble data (D[3:0]).
SR7-SR8	4 Frames after the "Exit Low-Power mode" command, the sensor starts outputting valid video data.

**Figure 9 : Resetting the VV6404 Sensor via the Serial Interface.**

PU0	System Power Up or Sensor Hot Plugged
PU1	Sensor Internal-on Reset Triggers, the sensor enters low power mode and D[3:0] is set to F <sub>H</sub> .
PU2	Video Processor released from reset.
PU3	Video Processor enables the sensor clock, CLKI.
PU4-PU5	At least 16 CLKI clock periods after CLKI has been enabled the VP sends a “Soft-Reset” command to the sensor via the serial interface. This ensures that if a sensor is present then it is in low-power mode.
PU6	On detecting 32 consecutive F <sub>H</sub> values on D[3:0], the Video Processor sets the no_camera low.
PU7-PU8	If present, upload the sensor defect map from E <sup>2</sup> PROM into the Video Processor
PU9	Video Processor disables the sensor clock, CLKI.
PU10	Video Processor generates the VP_Ready interrupt.
PU11	The host software services the VP_Ready interrupt.
PU12	Host issues command to remove sensor from low-power mode. VP enables the sensor clock, CLKI.
PU13-PU4	At least 16 CLKI clock periods after CLKI has been enabled the VP sends the “Exit Low-Power Mode” command to the sensor via the serial interface. This initiates the sensors 4 frame start sequence.
PU15-PU16	One frame of alternating 9 <sub>H</sub> & 6 <sub>H</sub> data on D[3:0] for the video processor to determine the best sampling phase for the nibble data (D[3:0]).
PU17-PU18	4 Frames after the “Exit Low-Power Mode” serial comms, the sensor starts outputting valid video data.

**Table 7 : System Power-Up or Hot-plugging Device Behaviour**

### 4.6.1 Power-Up/Down (Figure 12)

On power-up all of the databus lines will go high immediately ( $F_H$ ), to indicate that the device is “present” and the device enters its low-power mode (Section 4.6.2).

When the Video Processor is reset the following sequence should be executed to ensure that the VM6404 starts to generate video data:

1. After the Video Processor has been released from reset, the sensor clock, CLKI, should be enabled immediately
2. After waiting for at least 16 CLKI clock cycles, a “Soft Reset” command should be issued to the sensor. This is necessary to ensure that the sensor is brought into a known state. If the sensor is not present then the serial interface communications by Video Processor will not be acknowledged.
3. Poll for 32 consecutive  $F_H$  values on the data bus, if this condition is satisfied then the sensor is present. The Video processor should set the camera\_present flag.
4. Determine if the serial CMOS E<sup>2</sup>PROM containing the defectivity map for the sensor is present and download the values.
5. Disable the sensor clock CKI.
6. The Video Processor should generate the VP\_Ready interrupt.
7. Once the host software serviced the VP\_Ready interrupt, then the sensor and video processor is ready to generate video data.
8. To enable video data, the host software, sets the low-power mode bit low. The video processor must enable CLKI at least 16 CLKI clock cycles before issuing the “Exit Low-Power Mode” command via the serial interface.

After the “Exit Low-Power Mode” command has been sent the sensor will output for one frame, a continuous stream of alternating  $9_H$  and  $6_H$  values on D[3:0]. By locking onto the resulting 0101/1010 patterns appearing on the data bus lines the video processor can determine the best sampling position for the nibble data. After the last  $9_H$   $6_H$  pair has been output the databus returns to  $F_H$  until the start of fifth frame after CKI has been enabled when the first active frame output. After the video processor has determined the correct sampling position for the data, it should then wait for the next start of frame line (SOF).

If the video processor detects 32 consecutive  $0_H$  values on the data bus, then the sensor has been removed. The sensor clock, CKI, should be held low.

### 4.6.2 Low-Power Mode (Figure 10)

Under the control of the serial interface the sensor analogue circuitry can be powered down and then be powered up. When the low-power bit is set via the serial interface, all the databus lines will go high at the end of the end of frame line of the current frame. At this point the analogue circuits in the sensor will power down. The system clock must remain active for the duration of low power mode.

Only the analogue circuits are powered down, the values of the serial interface registers e.g. exposure and gain are preserved.

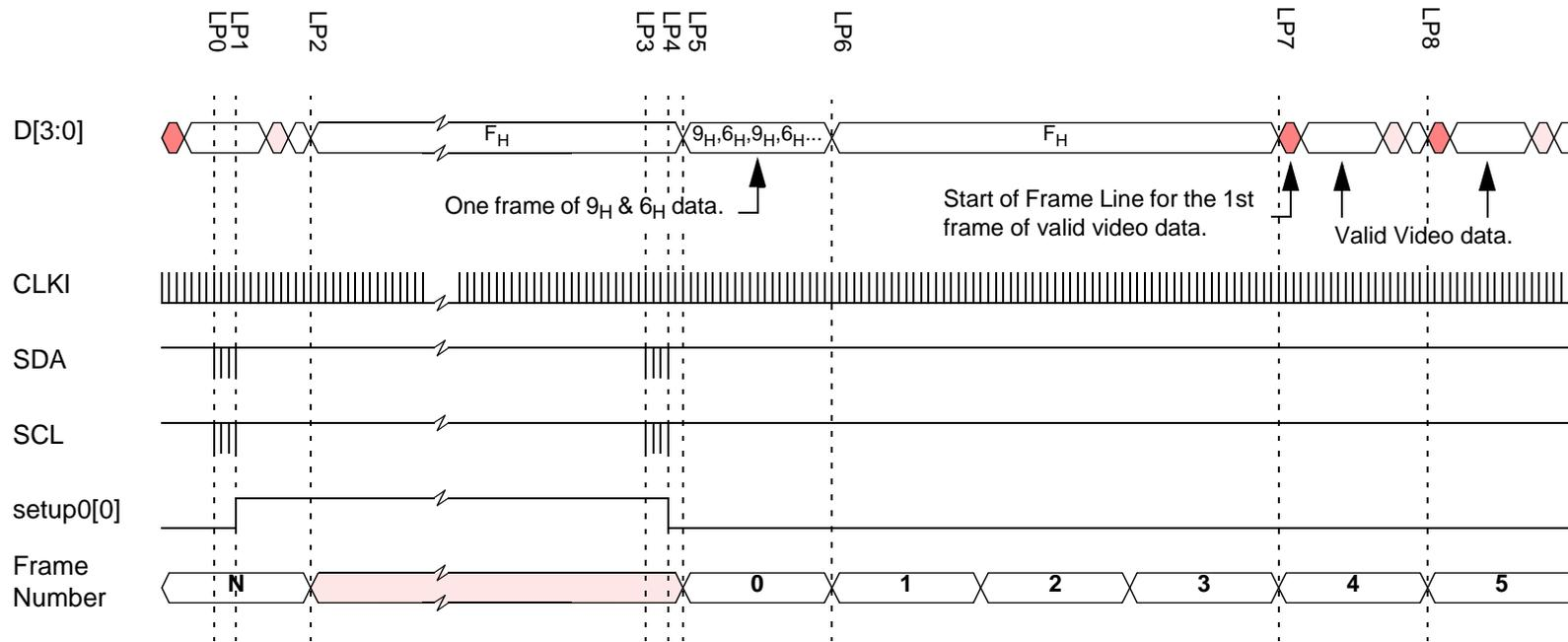
The internal frame timing is reset to the start of a video frame on exiting low-power mode.

In a similar manner to the previous section, the first frame after the serial comms contains a continuous stream of alternating  $9_H$  and  $6_H$  to allow the video processor to re-confirm its sampling position. Then three frames later the first start of frame line is generated.

### 4.6.3 Sleep Mode (Figure 11)

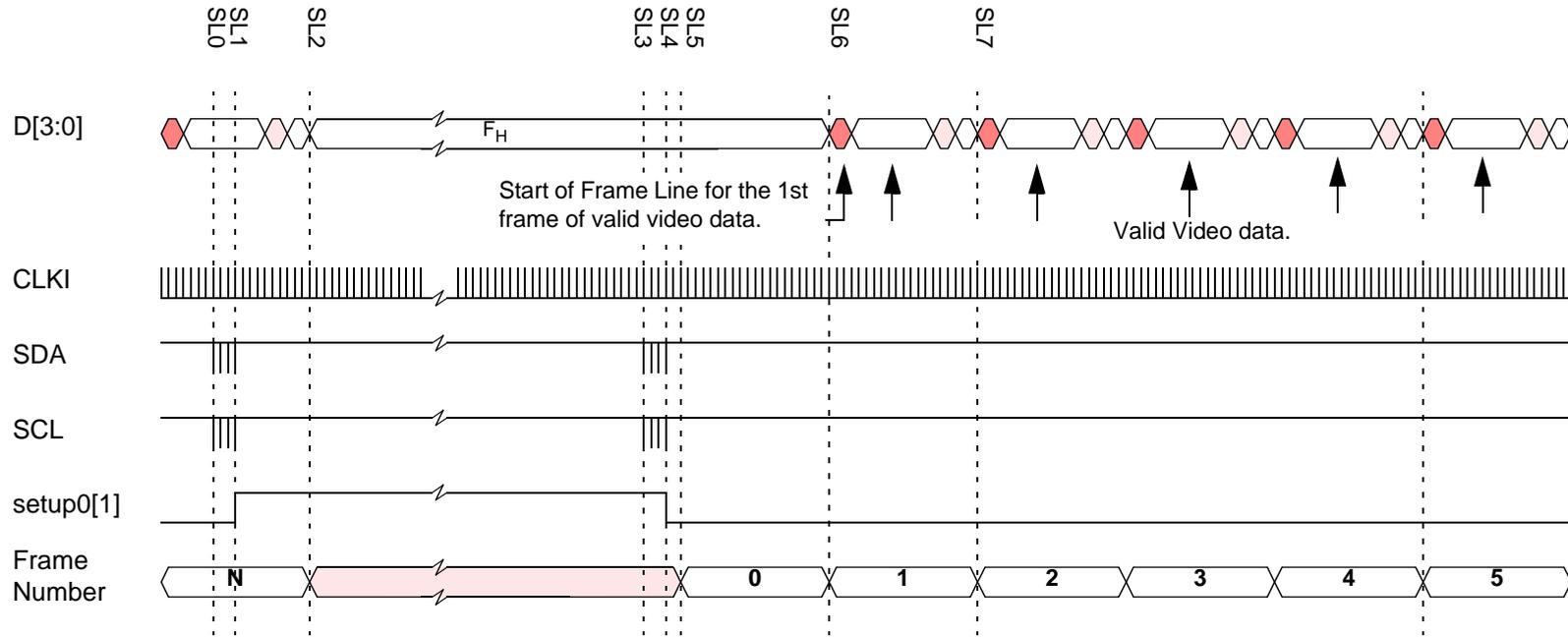
Sleep mode is similar to the low-power mode, except that analogue circuitry remains powered. When the sleep command is received via the serial interface the pixel array will be put into reset and the data lines all will go high at the end of the current frame. Again the system clock must remain active for the duration of sleep mode.

When sleep mode is disabled, the CMOS sensor’s frame timing is reset to the start of a frame. During the first frame after exiting from sleep mode the databus will remain high, while the exposure value propagates through the pixel array. At the start of the second frame the first start of field line will be generated.



LP0-LP1	"Enter Low Power Mode" Command.
LP2	At end of current frame, D[3:0] is set to $F_H$ and the VM6404 sensor's analogue circuitry is powered down.
LP3-LP4	"Exit Low Power Mode" Command. Powers-up analogue circuits and initiates the VM6404 sensor's 4-frame start-up sequence
LP5-LP6	1 Frame of alternating $9_H$ & $6_H$ data on D[3:0] for the video processor to determine the best sampling phase for the nibble data (D[3:0]).
LP7-LP8	4 Frames after the "Exit low Power Mode" command, the sensor starts outputting valid video data.

**Figure 10 : Entering and Exiting Low Power Mode.**



SL0-SL1	"Enter Sleep Mode" Command.
SL2	At end of current frame, $D[3:0]$ is set to $F_H$ .
SL3-SL4	"Exit Sleep Mode" Command. Powers-up analogue circuits and initiates the VM6404 sensor's 1-frame sleep start-up sequence
SL6-SL7	1 Frame after the "Exit Sleep Mode" command, the sensor starts outputting valid video data.

**Figure 11 : Entering and Exiting Sleep Mode.**

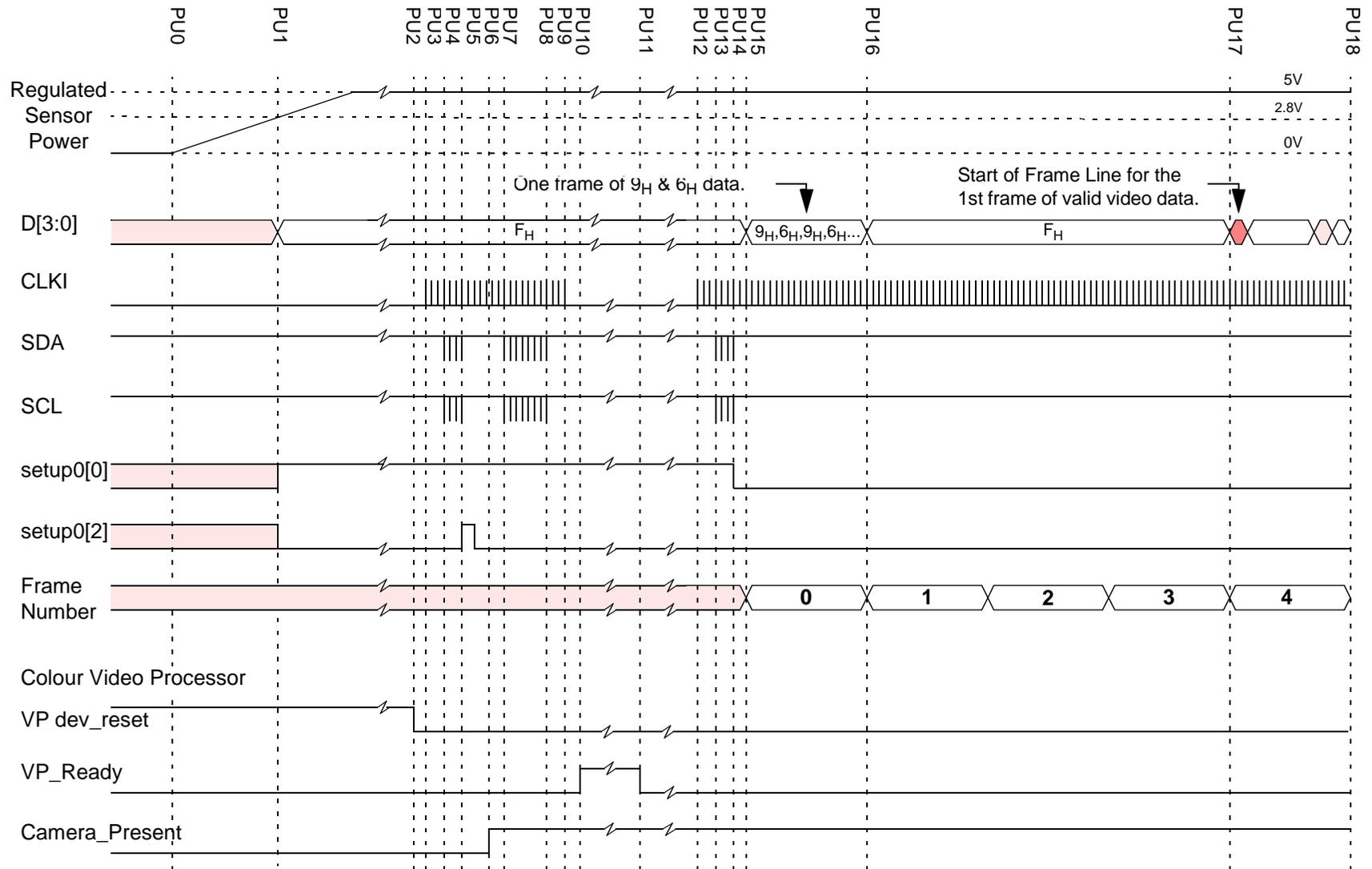


Figure 12 : System Power-Up or Hot-plugging Device Behaviour

#### 4.6.4 Application of the system clock during sensor low-power modes

For successfully entry and exit into and out of low power and 'sleep' modes the system clock, CLKI, must remain active for the duration of these modes.

#### 4.7 Qualification of Output Data

There are two distinct ways for qualifying the data nibbles appearing of the output data bus

##### 4.7.1 Using the External Clock signal applied to CKI

The data on the output data bus, changes on the rising edge of CKI. The delay between the video processor supplying a rising clock edge and the data on the databus becoming valid, depends on the length of the cable between the sensor and the video processor. To allow the video processor to find the best sampling position for the data nibbles, via the serial interface the databus can be forced to output continuously 9<sub>H</sub>, 6<sub>H</sub>, 9<sub>H</sub>, 6<sub>H</sub>,...

##### 4.7.2 Data Qualification Clock, QCK

VV6404 provides a data qualification clock for the output bus. There are two frequencies for the qualification clock: one runs at the nibble rate and the other at the pixel read-out rate. The falling edge of the fast QCK qualifies every nibble irrespective of whether it is most or least significant nibble. For the slow QCK, the rising edge qualifies the most significant nibbles in the output data stream and the falling edge qualifies the least significant nibbles in the output data stream.

There are 4 modes of operation of QCK.

1. Disabled (Always low - (Default)
2. Free running - qualifies the whole of the output data stream.
3. Embedded control sequences, status data and pixel data.
4. Pixel Data Only.

The operating mode for QCK is set via the serial interface. The QCK output is tristated when OEB is high. In one of the modes available via the serial interface the slow version of QCK will appear on the QCK pin while the fast version of the same signal will appear on the FST pin.

In the case where the border rows and columns are disabled, there is simply no qualification pulse at that point in time i.e. when pixels 0,1, 354 and 355 are normally output.

The QCK pin can also be configured to output the state of a serial interface register bit. This feature allows the sensor to control external devices, e.g. stepper motors, shutter mechanisms. The configuration details for QCK can be found in sections 5.5.7 and 5.5.8 of this document.

##### 4.7.3 Frame Start Signal, FST

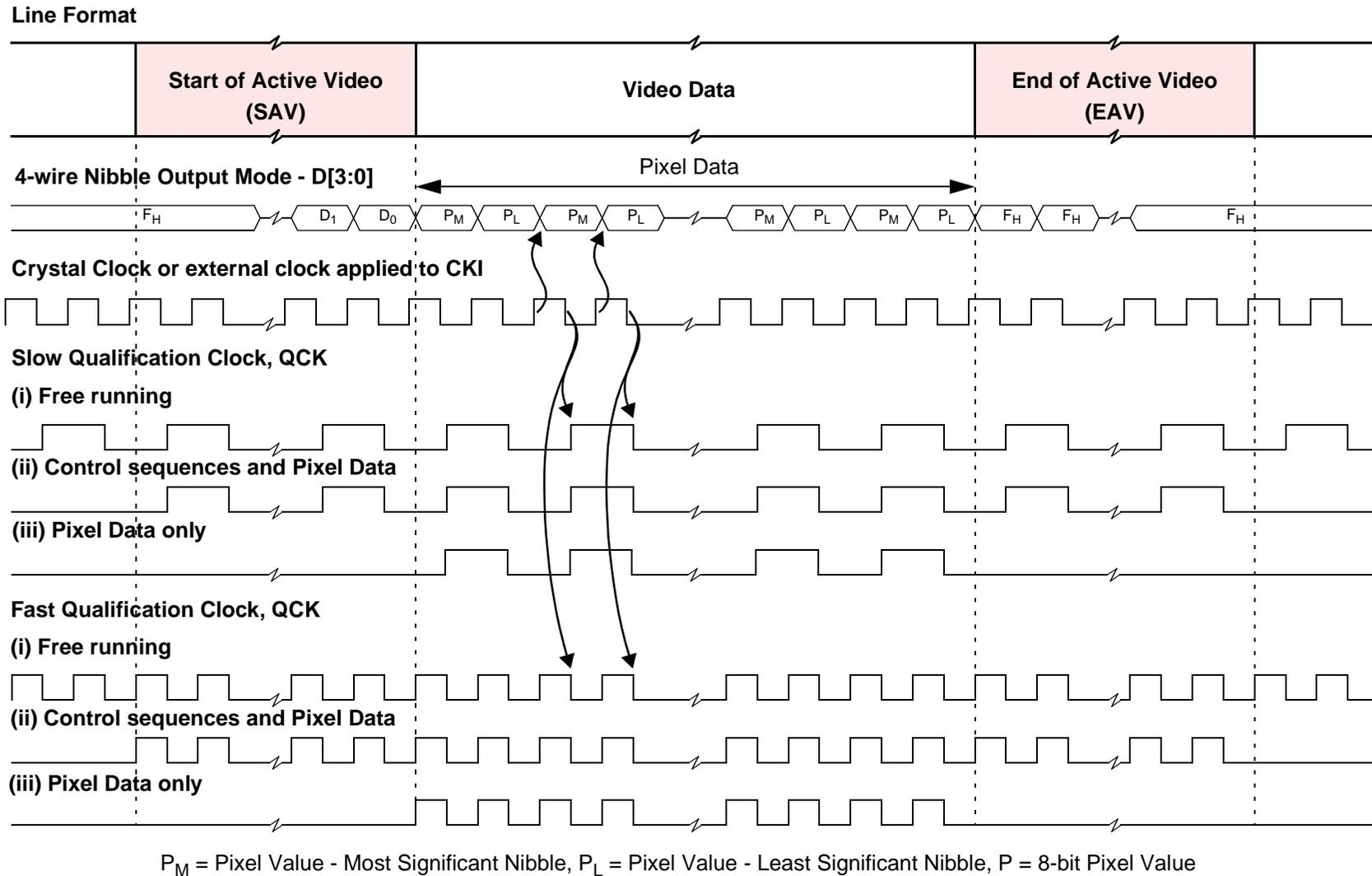
There are 3 modes of operation for the FST pin programmable via the serial interface:

1. Disabled (Always Low- Default).
2. Frame start signal. The FST signal occurs once frame, is high for 356 pixel periods (712 system clock periods) and qualifies the data in the start of frame line.

The FST is tristated when OEB is high.

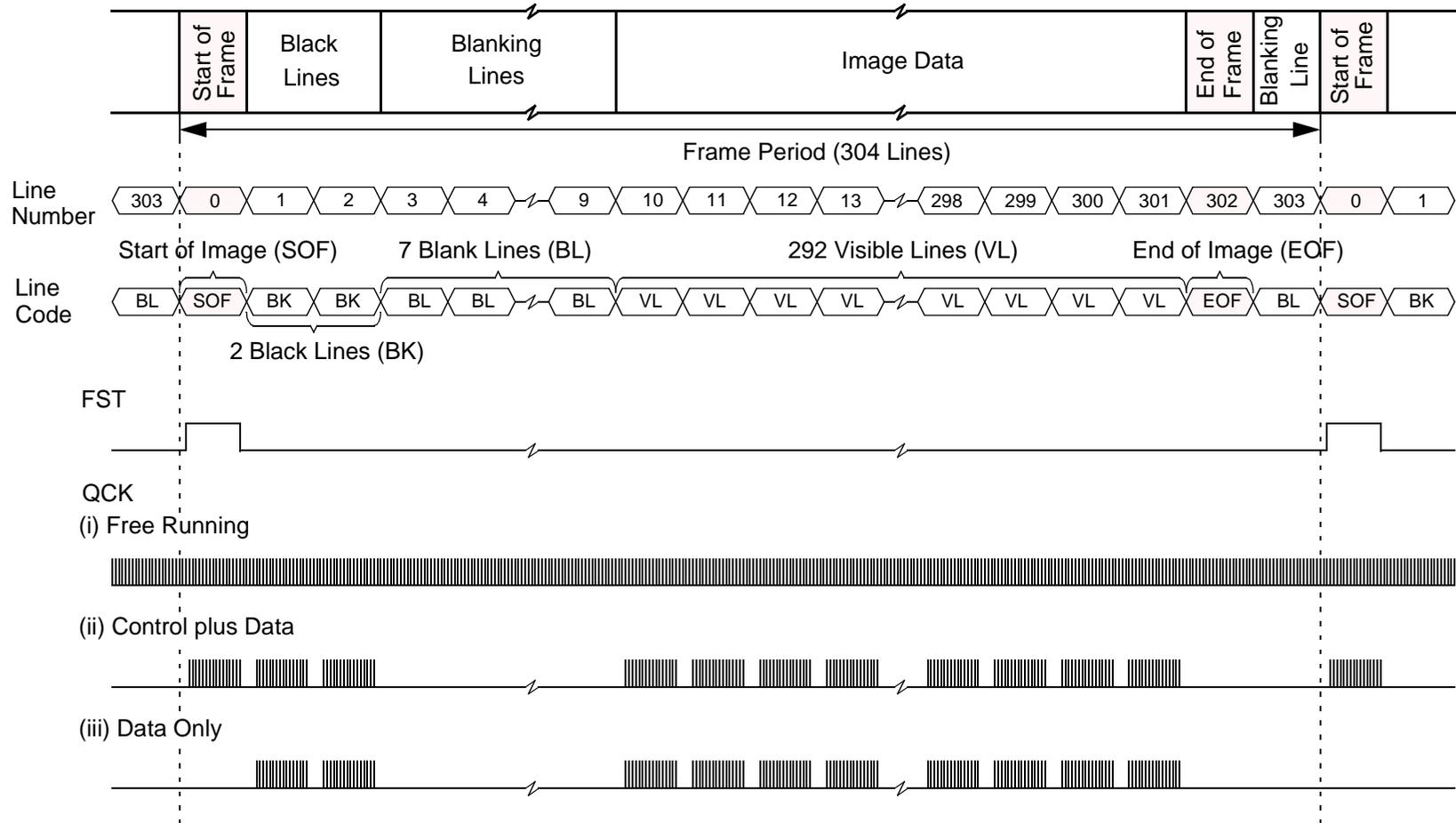
The FST pin can also be configured to output the state of a serial interface register bit. This feature allows the sensor to control external devices, e.g. stepper motors, shutter mechanisms.

The configuration details for FST can be found in sections 5.5.7 and 5.5.8 of this document.



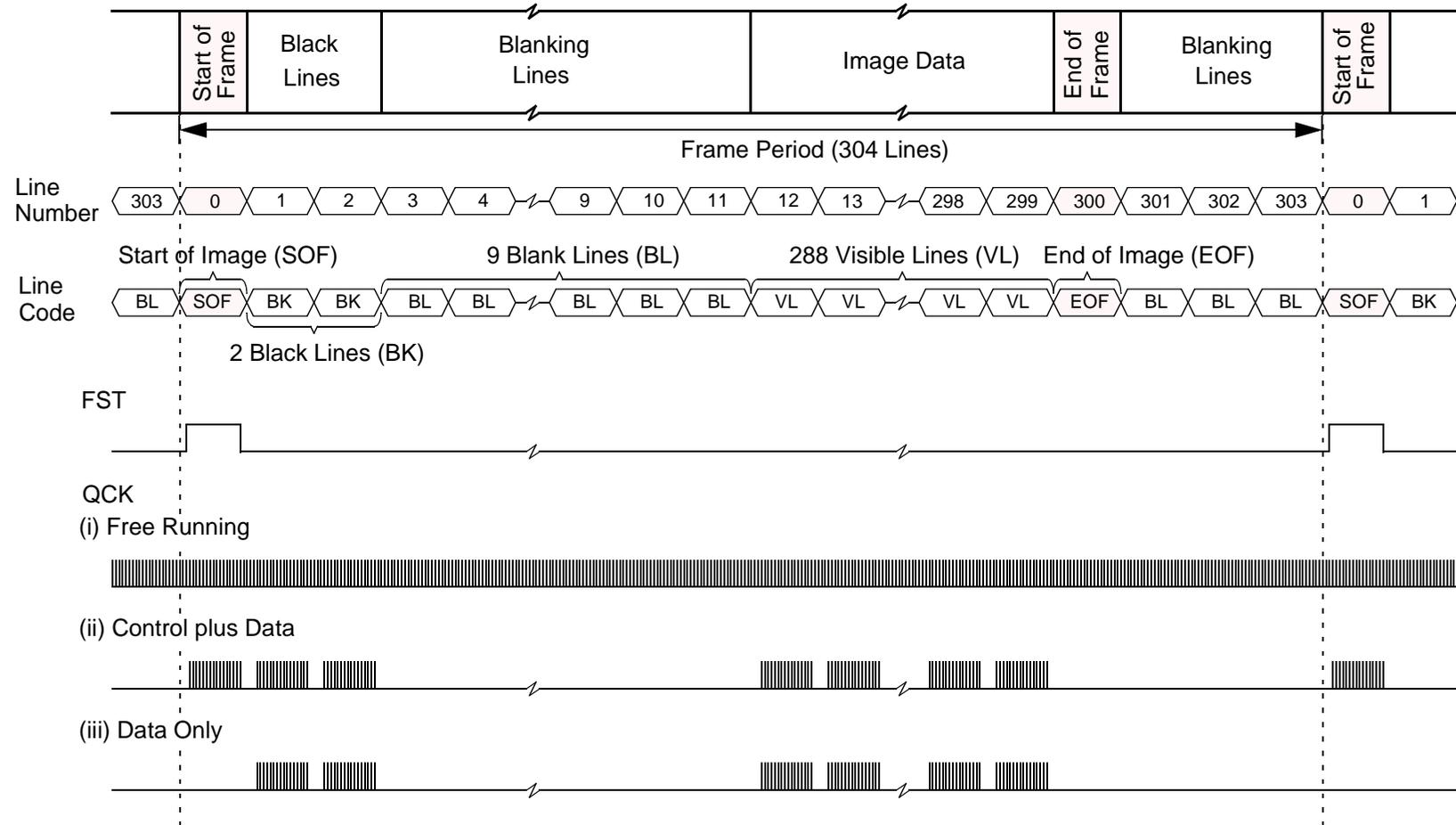
**Figure 13 : Qualification of Output Data (Border Rows and Columns Enabled).**

**Frame Format (Border rows and columns enabled - Default) :**



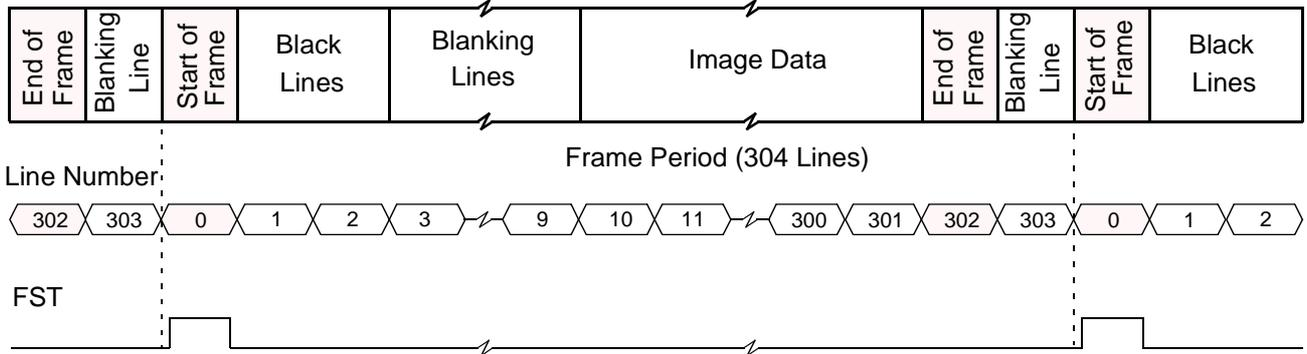
**Figure 14 : Frame Level Timings for FST and QCK (Border Rows and Columns Enabled).**

**Frame Format (Border rows and columns disabled) :**

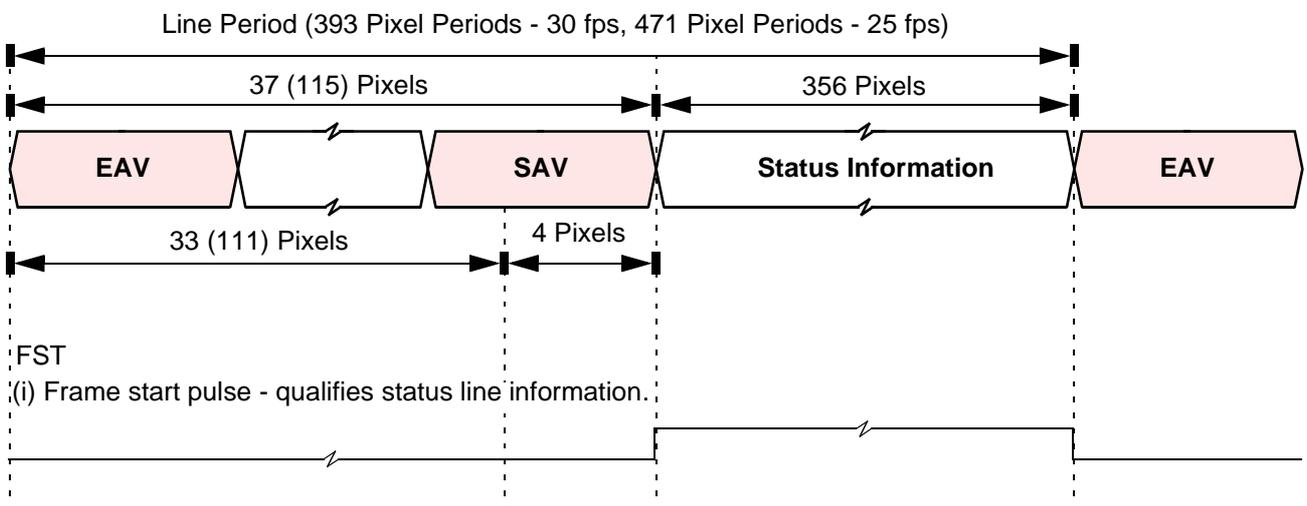


**Figure 15 : Frame Level Timings for FST and QCK (Border Rows and Columns Disabled).**

**Frame Format (Border rows and columns enabled in example):**



**Start of Frame Line Format:**



**Figure 16 : FST Pin Waveforms.**

## 5. Serial Control Bus

### 5.1 General Description

Writing configuration information to the video sensor and reading both sensor status and configuration information back from the sensor is performed via the 2-wire serial interface.

Communication using the serial bus centres around a number of registers internal to the video sensor. These registers store sensor status, set-up, exposure and system information. Most of the registers are read/write allowing the receiving equipment to change their contents. Others (such as the chip id) are read only.

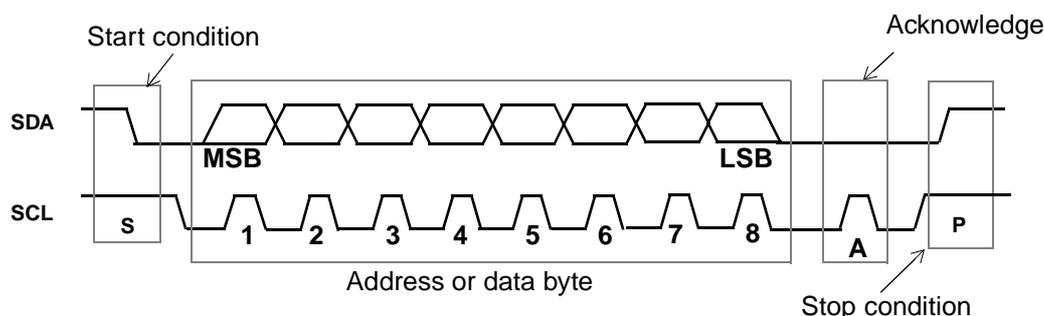
The main features of the serial interface include:

- Variable length read/write messages.
- Indexed addressing of information source or destination within the sensor.
- Automatic update of the index after a read or write message.
- Message abort with negative acknowledge from the master.
- Byte oriented messages.

The contents of all internal registers accessible via the serial control bus are encapsulated in each start-of-field line - see Section 4.3.4.

### 5.2 Serial Communication Protocol

The video processor must perform the role of a communications master and the camera acts as either a slave receiver or transmitter. The communication from host to camera takes the form of 8-bit data with a maximum serial clock video processor frequency of up to 100 kHz. Since the serial clock is generated by the host it determines the data transfer rate. The bus address for the sensor in VV6404 is 20<sub>H</sub> and for the serial E<sup>2</sup>PROM containing the defect map it is A0<sub>H</sub>. Data transfer protocol on the bus is shown below.



**Figure 17 : Serial Interface Data Transfer Protocol**

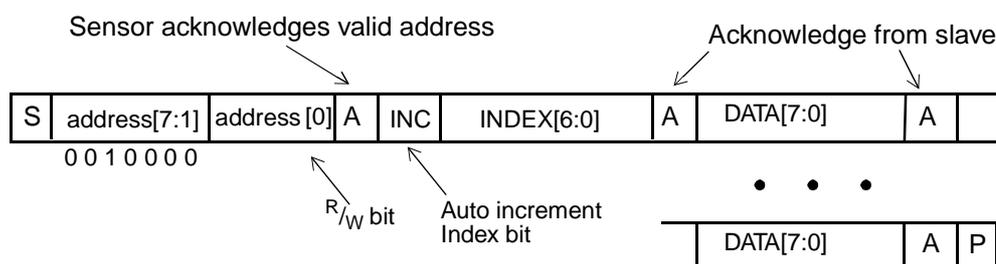
### 5.3 Data Format

Information is packed in 8-bit packets (bytes) always followed by an acknowledge bit. The internal data is produced by sampling *sda* at a rising edge of *scl*. The external data must be stable during the high period of *scl*. The exceptions to this are *start* (S) or *stop* (P) conditions when *sda* falls or rises respectively, while *scl* is high.

A message contains at least two bytes preceded by a *start* condition and followed by either a *stop* or *repeated start*, (*Sr*), followed by another message.

The first byte contains the device address byte which includes the data direction *read*, (*r*), *~write*, (*~w*), bit. The device address of VV6404 is fixed as 0010\_000\_[lsb]<sub>2</sub>. The lsb of the address byte indicates the direction of the message. If the lsb is set high then the master will read data from the slave and if the lsb is reset low then the master will write data to the slave. After the *r,~w* bit is sampled, the data direction cannot be changed, until the next address byte with a new *r,~w* bit is received.

The byte following the address byte contains the address of the first data byte (also referred to as the *index*). The serial interface can address up to 128, byte registers. If the msb of the second byte is set the automatic increment feature of the address index is selected.



**Figure 18 : Serial Interface Data Format**

#### 5.4 Message Interpretation

All serial interface communications with the sensor must begin with a *start* condition. If the *start* condition is followed by a valid address byte then further communications can take place. The sensor will acknowledge the receipt of a valid address by driving the *sda* wire low. The state of the *read/~write* bit (lsb of the address byte) is stored and the next byte of data, sampled from *sda*, can be interpreted.

During a write sequence the second byte received is an address index and is used to point to one of the internal registers. The msbit of the following byte is the *index auto increment* flag. If this flag is set then the serial interface will automatically increment the index address by one location after each slave acknowledge. The master can therefore send data bytes continuously to the slave until the slave fails to provide an acknowledge or the master terminates the write communication with a *stop* condition or sends a *repeated start*, (*Sr*). If the auto increment feature is used the master does *not* have to send indexes to accompany the data bytes.

As data is received by the slave it is written bit by bit to a serial/parallel register. After each data byte has been received by the slave, an acknowledge is generated, the data is then stored in the internal register addressed by the current index.

During a read message, the current index is read out in the byte following the device address byte. The next byte read from the slave device are the contents of the register addressed by the current index. The contents of this register are then parallel loaded into the serial/parallel register and clocked out of the device by *scl*.

At the end of each byte, in both read and write message sequences, an acknowledge is issued by the receiving device. Although VV5404 and VV6404 is always considered to be a slave device, it acts as a transmitter when the bus master requests a read from the sensor.

At the end of a sequence of incremental reads or writes, the terminal index value in the register will be one *greater* the last location read from or written to. A subsequent read will use this index to begin retrieving data from the internal registers.

A message can only be terminated by the bus master, either by issuing a stop condition, a repeated start condition or by a negative acknowledge after reading a complete byte during a read operation.

## 5.5 The Programmers Model

There may be up to 128, 8-bit registers within the camera, accessible by the user via the serial interface. They are grouped according to function with each group occupying a 16-byte page of the location address space. There may be up to eight such groups, although this scheme is purely a conceptual feature and not related to the actual hardware implementation, The primary categories are given below:

- Status Registers (Read Only).
- Setup registers with bit significant functions.
- Exposure parameters that influence output image brightness.
- System functions and analogue test bit significant registers.

Any internal register that can be written to can also be read from. There are a number of read only registers that contain device status information, (e.g. design revision details).

Names that end with H or L denote the most or least significant part of the internal register. Note that unused locations in the H byte are packed with zeroes.

STMicroelectronics sensors that include a 2-wire serial interface are designed with a common address space. If a register parameter is unused in a design, but has been allocated an address in the generic design model, the location is referred to as **reserved**. If the user attempts to read from any of these **reserved** locations a default byte will be read back. In VV6404 this data is the LSByte of the device status word, address 000\_0000. A write instruction to a reserved (but unused) location is illegal and would not be successful as the device would not allocate an internal register to the data word contained in the instruction.

A detailed description of each register follows. The address indexes are shown as binary numbers in brackets [].

	Index	Name	Length	R/W	Default	Comments
Status	000_0000	deviceH	8	RO	0001 1001 <sub>2</sub>	Chip identification number including revision indicator
	000_0001	deviceL	8	RO	0100 0000 <sub>2</sub>	
	000_0010	status0	8	RO	0000 1000 <sub>2</sub>	
	000_0011	line_countH	8	RO		Current line counter MSB value
	000_0100	line_countL	8	RO		Current line counter LSB value
	000_0101	Unused				
	000_011x	Unused				
	000_1xxx	Unused				
Setup	001_0000	setup0	8	R/W	0001 0001 <sub>2</sub>	
	001_0001	setup1	8	R/W	1100 0001 <sub>2</sub>	
	001_0010	setup2	8	R/W	31	Contains pixel counter reset value used by external sync.
	001_0011	Reserved				
	001_0100	setup4	8	R/W	0	FST and QCK mode selects
	001_0101	setup5	8	R/W	0	FST and QCK mapping mode.
	001_011x	Unused				
	001_1xxx	Unused				
Exposure	010_0000	fineH	8	R/W	0	Fine exposure.
	010_0001	fineL	8	R/W		
	010_0010	coarseH	8	R/W	302	Coarse exposure
	010_0011	coarseL	8	R/W		
	010_0100	gain	3	R/W	0	ADC Pre-amp gain Setting
	010_0101	clk_div	2	R/W	0	Clock division
	010_0110	Unused				
	010_0111	Unused				
	010_1xxx	Unused				
System	111_0000	Reserved				
	111_0001	Reserved				
	111_0010	Reserved				
	111_0011	Unused				
	111_0100	Reserved				
	111_0101	Reserved				
	111_0110	cr	8	R/W	0000 0000 <sub>2</sub>	Control Register
	111_0111	as0	8	R/W	0100 0100 <sub>2</sub>	ADC Setup Register
	111_1000	Reserved				
	111_1001	Unused				
	111_101x	Unused				
	111_11xx	Unused				

**Table 8 : Serial Interface Address Map.**

### 5.5.1 DeviceH [000\_0000<sub>2</sub>] and DeviceL [000\_0001<sub>2</sub>]

These registers provide read only information that identifies the sensor type that has been coded as a 12bit number and a 4bit mask set revision identifier. The device identification number for VV6404 is 404 i.e. 0001 1001 0100<sub>2</sub>. The initial mask revision identifier is 0 i.e. 0000<sub>2</sub>.

Bits	Function	Default	Comment
7:0	Device type identifier	0001 1001 <sub>2</sub>	Most significant 8 bits of the 12 bit code identifying the chip type.

**Table 9 : DeviceH [000\_0000<sub>2</sub>]**

Bits	Function	Default	Comment
7:4	Device type identifier	0100 <sub>2</sub>	Least significant 4 bits of the 12 bit code identifying the chip type.
3:0	Mask set revision identifier	0000 <sub>2</sub>	

**Table 10 : DeviceL [000\_0001<sub>2</sub>]**

### 5.5.2 Status0 [000\_0010<sub>2</sub>]

Bit	Function	Default	Comment
0	Exposure value update pending	0	Exposure sent but not yet consumed by the exposure controller
1	Gain value update pending	0	Gain value sent but not yet consumed by the exposure controller
2	Clock divisor update pending	0	Clock divisor sent but not yet consumed by the exposure controller
3	Black cal fail flag	0	If the black calibration has failed this flag will be raised. It will stay active until the last line of the next <b>successful</b> black calibration.
4	Odd/even frame	1	The flag will toggle state on alternate frames
7:5	Unused	000	

**Table 11 : Status0 [000\_0010<sub>2</sub>]**

### 5.5.3 Line\_count\_H [000\_0011<sub>2</sub>] & Line\_count\_L [000\_0100<sub>2</sub>]

Register Index	Bits	Function	Default	Comment
000_0011 <sub>2</sub>	7:0	Current line count MSB	-	Displays current line count
000_0100 <sub>2</sub>	7:0	Current line count LSB	-	

**Table 12 : Current Line Counter Value.**

5.5.4 Setup0 [001\_0000<sub>2</sub>]

Bit	Function	Default	Comment
0	Low Power Mode: <b>Off/On</b>	1	Powers down the sensor array. The output databus goes to F <sub>H</sub> . On power-up the sensor enters low power mode.
1	Sleep Mode: <b>Off/On</b>	0	Puts the sensor array into reset. The output databus goes to F <sub>H</sub> .
2	Soft Reset <b>Off/On</b>	0	Setting this bit resets the sensor to its power-up defaults. This bit is also reset.
3	Frame Rate select: 25 fps or <b>30 fps</b>	1	
4	Tri-state output data bus <b>Outputs Enabled/Tristate</b>	0	On power up the data output pads D[3:0] are enabled by default.
7:5	unused		

Table 13 : Setup0 [001\_0000<sub>2</sub>]5.5.5 Setup1 [001\_0001<sub>2</sub>]

Bit	Function	Default	Comment
1:0	Black calibration mode selection	10	Black calibration trigger selection. Default setting bases decision on result of monitor test. See table below
2	reserved		
3	Enable immediate clock division update. <b>Off/On</b>	0	Allow manual change to clock division to be applied immediately
4	Enable immediate gain update. <b>Off/On</b>	0	Allow manual change to gain to be applied immediately
5	Enable additional black lines (lines 3-9) <b>Off/On</b>	0	If enabled this bit will also enable the line immediately following the end of frame line
6	Border rows and columns: Masked or <b>Output</b>	1	These extra pixels/rows are used in colour processing
7	Pixel read-out order: Unshuffled or <b>Shuffled</b>	1	It is strongly recommended to use shuffled read-out.

Table 14 : Setup1 [001\_0001<sub>2</sub>]

Black Cal Mode[1]	Black Cal Mode[0]	Comment
0	0	No black calibration
0	1	<b>Always</b> trigger black calibration
1	0	Black calibration triggered by a <b>failed</b> monitor test
1	1	Trigger black calibration only if the gain setting changes

Table 15 : Black Calibration Mode

If the gain change trigger option has been selected then care should be taken when writing the new gain value *if* the **immediate gain update** option has been selected. It is strongly advised that the user should **not** write a new gain value between line 0 (the status line) and line 9 (the last black calibration line). If the gain values are written in a timed manner then no restriction applies.

#### 5.5.6 Setup2 [001\_0010<sub>2</sub>]

Bit	Function	Default	Comment
5:0	Pixel counter reset value	31	<b>NOTE:</b> For proper synchronisation this register should be written with the value 30.
7:6	Unused		

Table 16 : Setup2[001\_0010<sub>2</sub>]

#### 5.5.7 Setup4 [001\_0100<sub>2</sub>]

Bit	Function	Default	Comment
1:0	FST/QCK pin modes	0	Selection of FST, QCK pin data
3:2	QCK modes	0	When to output QCK
5:4	Reserved	0	reserved for LST modes in other sensors
7:6	FST modes	0	

Table 17 : Setup4[001\_0100<sub>2</sub>]

FST/QCK pin mode[1:0]		FST pin	QCK pin
0	0	FST	Slow QCK
0	1	FST	Fast QCK
1	0	Fast QCK	Slow QCK
1	1	Invert of Fast QCK	Fast QCK

Table 18 : FST/QCK Pin Selection

QCK mode[1:0]		QCK state
0	0	Off
0	1	Free Running
1	0	Valid during data and control period of line ( <i>see note</i> )
1	1	Valid only during data period of line

**Table 19 : QCK Modes**

*Note:* Not currently verified. Contact STMicroelectronics for further information if this mode is to be used.

FST mode[1:0]		FST state
0	0	Off
0	1	On - qualifies the status line
1	0	Reserved
1	1	Unallocated

**Table 20 : FST Modes**

The option to enable the qclk during the data and control period of the line **must not be selected if monochrome (shuffled or unshuffled) video has been selected.**

### 5.5.8 Setup5 [001\_0101<sub>2</sub>]

It is important to note that although the output buffer driver strengths can be selected by writing to this register the programmed values **cannot** be read back by the serial interface.

Bit	Function	Default	Comment
0	Map serial interface register bits values on to the QCK and FST pins <b>Off/On</b>	0	
1	Serial Interface Bit for QCK pin	0	
2	Serial Interface Bit for FST pin	0	
3	Output driver strength select	1	Default setting selects 4mA driver
4	Output driver strength select	0	Default setting selects 4mA drivers
7:5	Unused	0	

**Table 21 : Setup4[001\_0101<sub>2</sub>]**

Mapping Enable	FST pin	QCK pin
0	FST	QCK
1	su5[2]	su5[1]

**Table 22 : FST/QCK Pin Selection**

oeb_composite	su5[4]	su5[3]	Comments
0	0	0	Drive strength = 2mA
0	0	1	Default drive strength = 4mA
0	1	0	Drive strength = 6mA
0	1	1	unallocated
1	x	x	Outputs are not being driven therefore driver strength is irrelevant

**Table 23 : Output driver strength selection**

### 5.5.9 Exposure Control Registers [010\_0000<sub>2</sub>] - [010\_1001<sub>2</sub>]

There is a set of programmable registers which controls the sensitivity of the sensor. The registers are as follows:

1. Fine exposure.
2. Coarse exposure time.
3. Gain.
4. Clock division.

The gain parameter does not affect the integration period rather it amplifies the video signal at the output stage of the sensor core.

*Note:* The external exposure (coarse, fine, clock division or gain) values do not take effect immediately. Data from the serial interface is read by the exposure algorithm at the start of a video frame. If the user reads an exposure value via the serial interface then the value reported will be the data as yet unconsumed by the exposure algorithm, because the serial interface logic locally stores all the data written to the sensor.

Between writing the exposure data and the point at which the data is consumed by the exposure logic, bit 0 of the status register is set. The gain value is updated a frame later than the coarse, fine and clock division parameters, since the gain is applied directly at the video output stage and does not require the long set up time of the coarse and fine exposure and the clock division.

To eliminate the possibility of the sensor array seeing only part of the new exposure and gain setting, if the serial interface communications extends over a frame boundary, the internal re-timing of exposure and gain data is disabled while writing data to any location in the Exposure page of the serial interface register map. Thus if the 5 bytes of exposure and gain data is sent as an auto-increment sequence, it is not possible for the sensor to consume only part of the new exposure and gain data.

The range of some parameter values is limited and any value programmed out-with this range will be clipped to the maximum allowed.

Register Index	Bits	Function	Default	Comment
010_0000 <sub>2</sub>	7:0	Fine MSB exposure value	0	Maximum mode dependent: 360 (30fps) / 438 (25 fps)
010_0001 <sub>2</sub>	7:0	Fine LSB exposure value		
010_0010 <sub>2</sub>	7:0	Coarse MSB exposure value	302	Maximum: 302
010_0011 <sub>2</sub>	7:0	Coarse LSB exposure value		
010_0100 <sub>2</sub>	2:0	Gain value	0	000: Gain = 1 001: Gain = 2 011: Gain = 4 111: Gain = 8
010_0101 <sub>2</sub>	1:0	Clock divisor value	0	00: Pixel clock = CLKI clock/2 01: Pixel clock = CLKI clock/4 10: Pixel clock = CLKI clock/8 11: Pixel clock = CLKI clock/16

**Table 24 : Exposure, Clock Rate and Gain Registers**

Bit	Function	Default	Comment
0	Standby <b>Off/On</b>	0	Powers down ALL analogue circuitry
1	Power Down - ADC <b>Off/On</b>	0	
2	Power Down - ADC Top Reference <b>Off/On</b>	0	
5:3	Reserved		
7:6	Unused		

**Table 25 : Control Register CR [111\_0110<sub>2</sub>]**

Notes:

1. The enable signal enabling the external ADC functionality is the logical OR of CR0[0] bit and the invert of the ADCVDD pin.
2. The low-power select signal for the analogue circuitry is the logical OR of PD0[0] and Setup0[0].

5.5.10 ADC Setup Register AS0 [111\_0111<sub>2</sub>]

Bit	Function	Default	Comment
1:0	ADC Clock Fine Delay Setting <b>0 ns</b> / 4 ns / 8 ns / 16 ns	00	00: Clock Delay = 0 ns (Default) 01: Clock Delay = 4 ns 10: Clock Delay = 8 ns 11: Clock Delay = 16 ns
3:2	ADC Clock Phase Delay Setting 0° / <b>90°</b> / 180° / 270°	01	00: Phase Delay = 0° 01: Phase Delay = 90° (Default) 10: Phase Delay = 180° 11: Phase Delay = 270°
5:4	PCK Clock Fine Delay Setting <b>0 ns</b> / 4 ns / 8 ns / 16 ns	00	00: Clock Delay = 0 ns (Default) 01: Clock Delay = 4 ns 10: Clock Delay = 8 ns 11: Clock Delay = 16 ns
7:6	Reserved	1	

Table 26 : ADC Setup Register AS0 [111\_0111<sub>2</sub>]

## 5.6 Types of messages

This section gives guidelines on the basic operations to read data from and write data to the serial interface.

The serial interface supports variable length messages. A message may contain no data bytes, one data byte or many data bytes. This data can be written to or read from common or different locations within the sensor. The range of instructions available are detailed below.

- Write no data byte, only sets the index for a subsequent read message.
- Single location multiple data write or read for monitoring (real time control)
- Multiple location, multiple data read or write for fast information transfers.

Examples of these operations are given below. A full description of the internal registers is given in the previous section. For all examples the slave address used is  $32_{10}$  for writing and  $33_{10}$  for reading. The write address includes the read/write bit (the lsb) set to zero while this bit is set in the read address.

### 5.6.1 Single location, single data write.

When a random value is written to the sensor, the message will look like this:

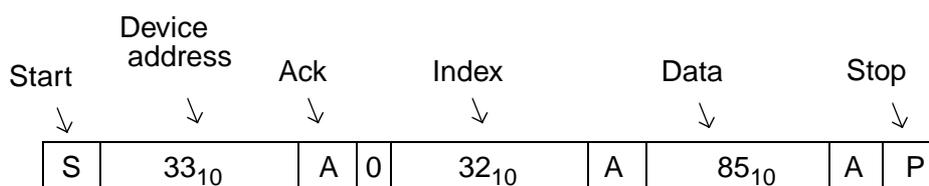


**Figure 19 : Single location, single write.**

In this example, the *fineH* exposure register (index =  $32_{10}$ ) is set to  $85_{10}$ . The r/w bit is set to zero for writing and the *inc* bit (msbit of the index byte) is set to zero to disable automatic increment of the index after writing the value. The address index is preserved and may be used by a subsequent read. The write message is terminated with a stop condition from the master.

### 5.6.2 Single location, single data read.

A read message always contains the index used to get the first byte.

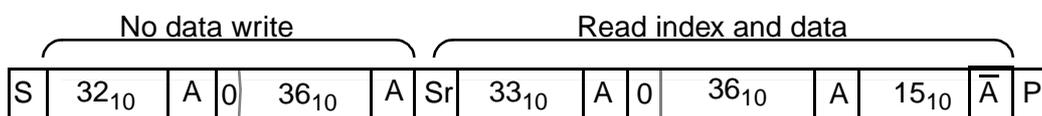


**Figure 20 : Single location, single read.**

This example assumes that a write message has already taken place and the residual index value is  $32_{10}$ . A value of  $85_{10}$  is read from the *fineH* exposure register. Note that the read message is terminated with a negative acknowledge ( $\bar{A}$ ) from the master: it is not guaranteed that the master will be able to issue a stop condition at any other time during a read message. This is because if the data sent by the slave is all zeros, the *sda* line cannot rise, which is part of the stop condition.

### 5.6.3 No data write followed by same location read.

When a location is to be read, but the value of the stored index is not known, a write message with no data byte must be written first, specifying the index. The read message then completes the message sequence. To avoid relinquishing the serial to bus to another master a repeated start condition is asserted between the write and read messages. In this example, the *gain* value (index =  $36_{10}$ ) is read as  $15_{10}$ :



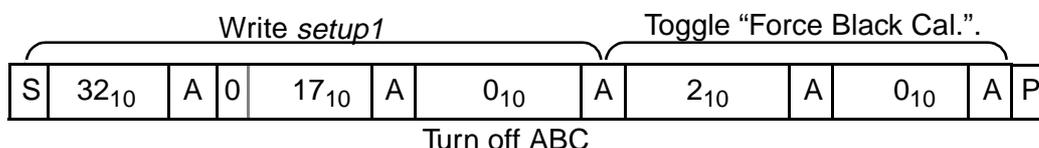
**Figure 21 : No data write followed by same location read.**

As mentioned in the previous example, the read message is terminated with a negative acknowledge ( $\bar{A}$ ) from the master.

**5.6.4 Same location multiple data write.**

It may be desirable to write a succession of data to a common location. This is useful when the status of a bit, (e.g. requesting a new black calibration), must be toggled.

The message sequence indexes *setup1* register. If bit 1 is toggled low, high low this will initiate a fresh black calibration. This is achieved by writing three consecutive data bytes to the sensor. There is no requirement to re-send the register index before each data byte.

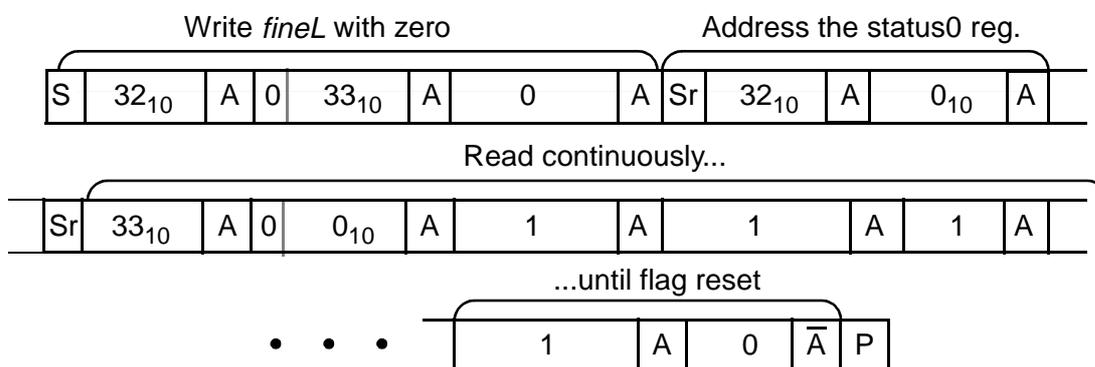


**Figure 22 : Same location multiple data write.**

**5.6.5 Same location multiple data read**

When an exposure related value (*fineH*, *fineL*, *coarseH*, *coarse L*, *gain* or *clk\_div*) is written, it takes effect on the output at the beginning of the next video frame, (remember that the application of the *gain* value is a frame later than the other exposure parameters). To signal the consumption of the written value, a flag is set when any of the exposure or gain registers are written and is reset at the start of the next frame. This flag appears in *status0* register and may be monitored by the bus master. To speed up reading from this location, the sensor will repeatedly transmit the current value of the register, as long as the master acknowledges each byte read.

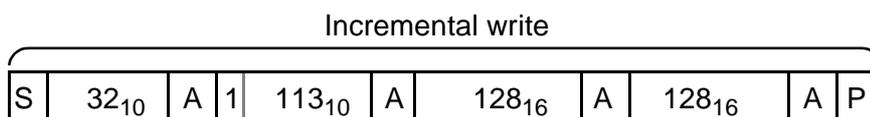
In the next example, a *fineH* exposure value of 0 is written, the status register is addressed (no data byte) and then constantly read until the master terminates the read message.



**Figure 23 : Same location multiple data read.**

### 5.6.6 Multiple location write

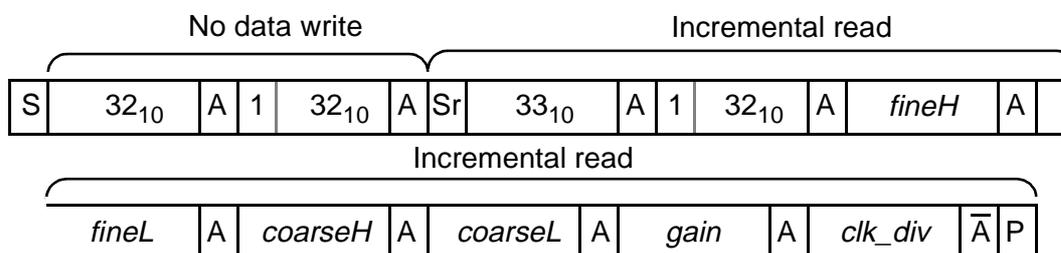
If the automatic increment bit is set, (msb of the index byte), then it is possible to write data bytes to consecutive adjacent internal registers without having to send explicit indexes prior to sending each data byte. An auto-increment write to the black calibration DAC registers with their default values is shown in the following example.



**Figure 24 : Multiple location write.**

### 5.6.7 Multiple location read

In the same manner, multiple locations can be read with a single read message. In this example the index is written first, to ensure the exposure related registers are addressed and then all six are read



**Figure 25 : Multiple location read.**

Note that a stop condition is not required after the negative acknowledge from the master.

## 5.7 Serial Interface Timing

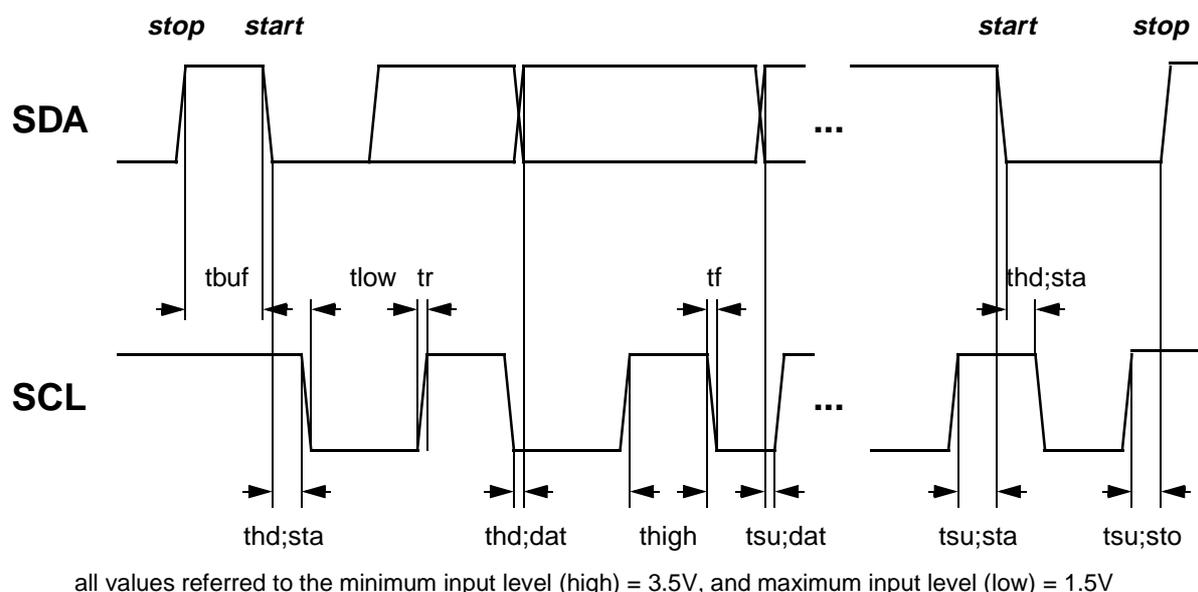


Figure 26 : Serial Interface Timing Characteristics

Parameter	Symbol	Min.	Max.	Unit
SCL clock frequency	fsc1	0	100	kHz
Bus free time between a <b>stop</b> and a <b>start</b>	tbuf	2	-	us
Hold time for a repeated <b>start</b>	thd;sta	80	-	us
LOW period of SCL	tlow	320	-	us
HIGH period of SCL	thigh	160	-	us
Set-up time for a repeated <b>start</b>	tsu;sta	80	-	us
Data hold time	thd;dat	0	-	us
Data Set-up time	tsu;dat	0	-	ns
Rise time of SCL, SDA	tr	-	300 (note1)	ns
Fall time of SCL, SDA	tf	-	300 (note1)	ns
Set-up time for a <b>stop</b>	tsu;sto	80	-	us
Capacitive load of each bus line (SCL, SDA)	Cb	-	200	pF

Table 27 : Serial Interface Timing Characteristics

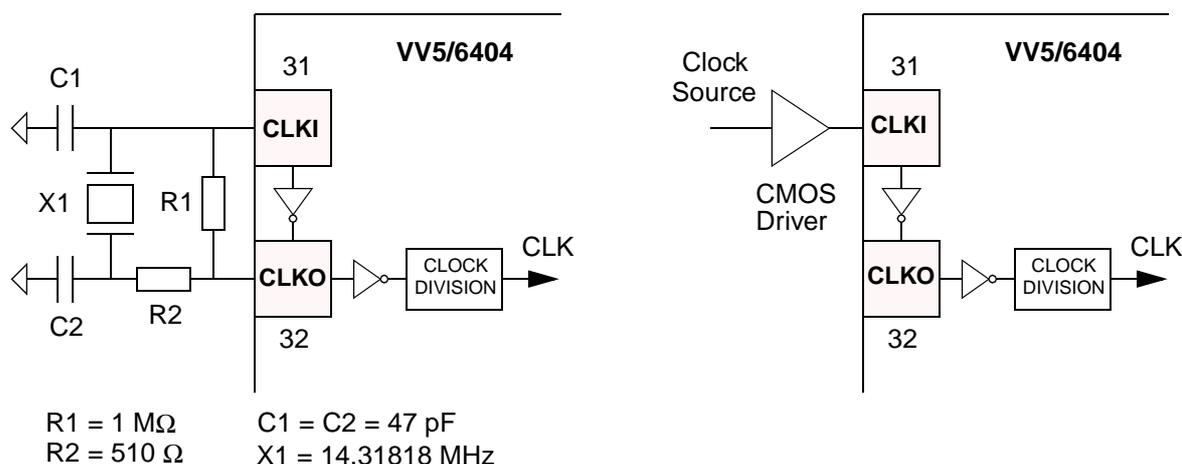
NOTE 1: With 200pF capacitive load. It is recommended that pull-up resistors of 2.2k - 4.7k are fitted to both SDA and SCL lines.

## 6. Clock Signal

VV5404 and VV6404 generate a system clock when a quartz crystal or ceramic resonator circuit is connected to the CLKI and CLKO pins. The device can also be driven directly from an external clock source driving CLK.

If CLKI is generated for the video sensor by the receiving device it must be active during serial interface communications for at least 16 clock cycles before the serial communications start bit and for at least 16 cycles after the serial communications stop bit.

The synchronisation input, SIN, synchronises the clock divider logic in addition to the main clock generation and the video timing control block.



**Figure 27 : Camera Clock Sources**

For greater flexibility the input frequency can be divided by 2, 4, 8 or 16 to select the pixel clock frequency. The clock divisor serial register selects the input clock frequency divisor.

The clock signal must be a square wave with a 50% (+/- 10%) mark:space ratio. Table 28 specifies the maximum and minimum pixel clock frequencies for the module. Table 29 and Table 29 specify the relationship between the input clock, CLKI, and the pixel clock frequency for the different settings of the sensor's internal clock divider.

	MHz
Minimum Pixel Rate	0.44744
Maximum Pixel Rate	3.57954

**Table 28 : Maximum and Minimum Pixel Rates**

This translates into a maximum input clock frequency of 7.15909 MHz if a clock divisor of 2 is used (the default - Table 29). Thus if a 14.31818 MHz crystal is used, only the 4, 8 and 16 clock divisors should be used (Table 29).

CLKI (MHz)	Clock Div Reg		Divisor	Pixel Frequency (MHz)	Frame rate (fps)		Comments
	bit 1	bit 0			30 fps	25 fps	
7.15909	0	0	2	3.57954	30.0	25.0	Default
7.15909	0	1	4	1.78977	15.0	12.5	
7.15909	1	0	8	0.89489	7.50	6.25	
7.15909	1	1	16	0.44744	3.75	3.125	

**Table 29 : Clock Divisors for an externally generated clock signal.**

CLKI (MHz)	Clock Div Reg		Divisor	Pixel Frequency (MHz)	Frame rate (fps)		Comments
	bit 1	bit 0			30 fps	25 fps	
14.31818	0	0	2	7.15909			Not Valid
14.31818	0	1	4	3.57954	30.0	25.0	
14.31818	1	0	8	1.78977	15.0	12.5	
14.31818	1	1	16	0.89489	7.50	6.25	

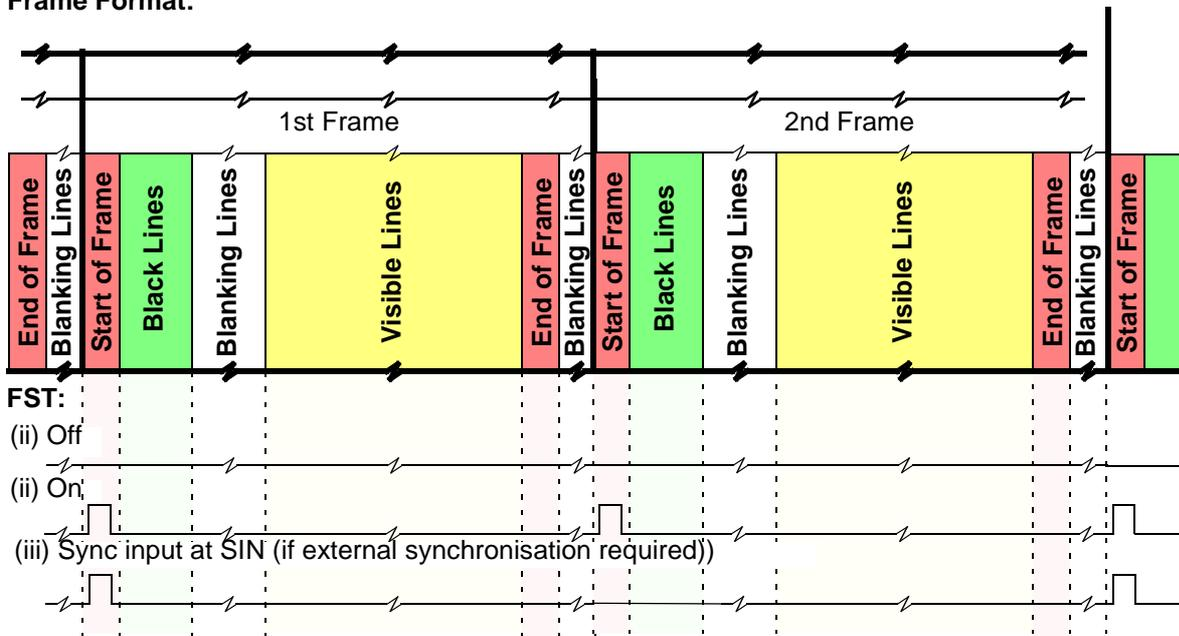
**Table 30 : Clock Divisors for a 14.31818 MHz Crystal**

## 6.8 Synchronising 2 or More Cameras

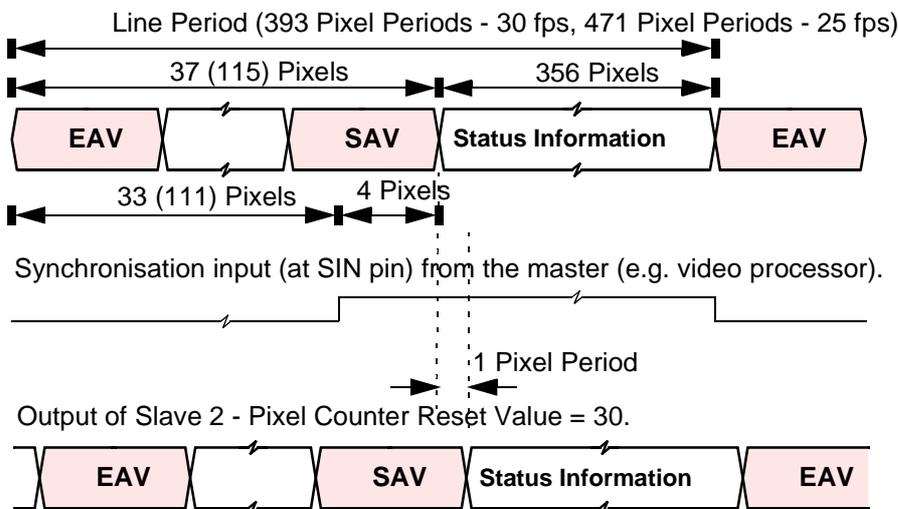
A rising edge on the SIN pin re-synchronises the sensor's internal video timing logic and clock generators to 5 pixels before the end of the start of frame control sequence in line 0 (assuming the Setup2 register has been programmed correctly with the value 30). By supplying an external timing signal to SIN, with a period equal to 2 frames (see Figure 28), 2 or more cameras can be synchronised together.

For proper synchronisation, the pixel counter register Setup2 must be written with 30, which will cause SIN to reset the video timing to 5 pixel periods before the end of the start of frame control sequence. SIN is sampled internally by the system clock, CKI. If all cameras are supplied with the same clock signal then the reset generated by SIN will synchronise all the cameras to the same point in time. However, if the cameras being synchronised are running at the same frequency but each camera has its own crystal, then there could be upto one system clock period of skew between the cameras. This skew will vary over time due to the slight mis-matches between frequencies of the different crystals.

**Frame Format:**



**Start of Frame Line Format:**



**Figure 28 : Synchronisation Waveforms**

## 7. Detailed specifications

### 7.1 General

Image Format	356 x 292 pixels (CIF)
Pixel Size	12.0 x 11.0µm
Array Format	CIF
Exposure control	25000:1 (performed by co-processor)
Sensor signal / Noise ratio	46dB
Minimum illumination	0.1 lux
Supply Voltage	5.0v DC +/-5%
Package type	48LCC
Operating Temp. range	0°C - 40°C*
Serial interface frequency range	0-100kHz
Supply Voltage	5.0 V DC +/- 5%
Supply Current	< 75 mA
Package type	48BGA

**Table 31 : VV5407/6407 Specifications**

\* Contact STMicroelectronics for information regarding increased temperature range

### 7.2 DC characteristics

Parameter	Min.	Max.	Notes
V <sub>IL</sub>	-0.5v	0.3 x V <sub>DD</sub>	Guaranteed input low voltage
V <sub>IH</sub>	0.7 x V <sub>DD</sub>	V <sub>DD</sub> + 0.5v	Guaranteed input high voltage
V <sub>OL</sub>		0.4V	At max I <sub>OL</sub> for pad type
V <sub>OH</sub>	2.4v	V <sub>DD</sub> - 0.5v	I <sub>OH</sub> = 100µA At max I <sub>OH</sub> for pad type
T <sub>J</sub> Junction Temp	0 deg C	100 deg C	
Internal Pullup resistor	35kΩ	150kΩ	
Internal Pulldown resistor	35kΩ	150kΩ	

**Table 32 : VV5407/6407 DC Characteristics**

8. Physical

8.1 Pinout Diagram

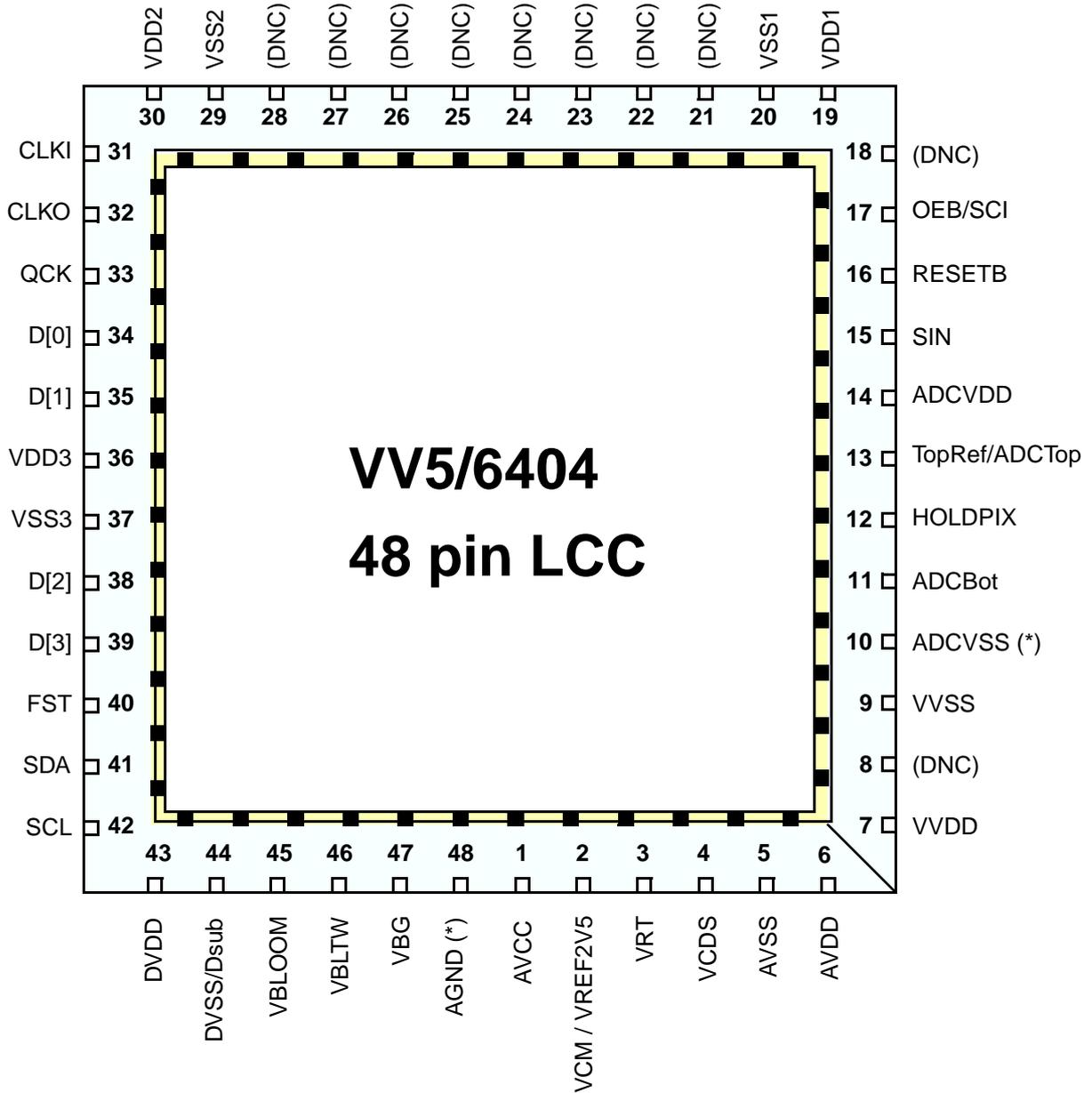


Figure 29 : Pinout

(DNC) - Do not connect these pins

(\*) - Paddle connections

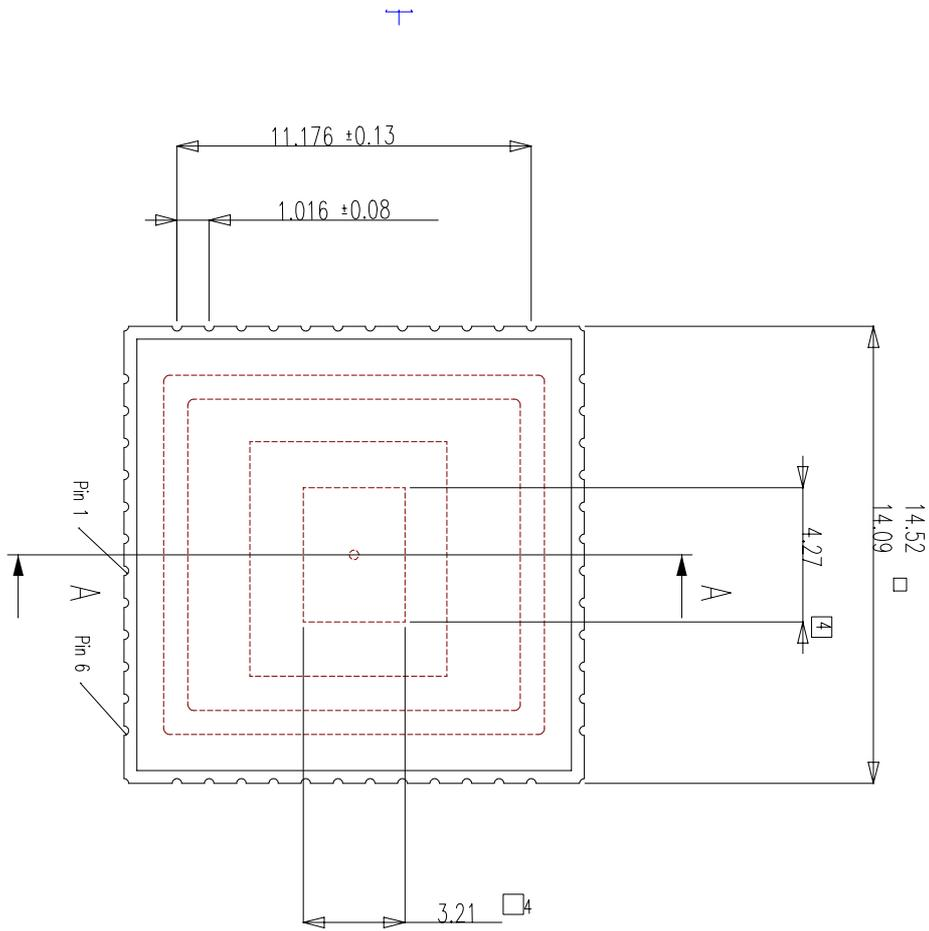
## 8.2 Signal Names

Pin	Name	Type	Description
<b>POWER SUPPLIES</b>			
1	AVCC	PWR	Core analogue power and reference supplies.
48	AGND	GND	Core analogue ground and reference supplies.
43	DVDD	PWR	Core digital power.
44	DVSS/Dsub	GND	Core digital ground.
6	AVDD	PWR	Output stage power.
5	AVSS	GND	Output stage ground.
7	VVDD	PWR	Analogue output buffer power.
9	VVSS	GND	Analogue output buffer ground.
14	ADCVDD	PWR	ADC power.
10	ADCVSS	GND	ADC ground.
19	VDD1	PWR	Digital padding & logic power.
30	VDD2	PWR	Digital padding & logic power.
36	VDD3	PWR	Digital padding & logic power.
20	VSS1	GND	Digital padding & logic ground.
29	VSS2	GND	Digital padding & logic ground.
37	VSS3	GND	Digital padding & logic ground.
<b>ANALOGUE SIGNALS</b>			
45	VBLOOM	OA	Anti-blooming pixel reset voltage
46	VBLTW	OA	Bitline test white level reference
47	VBG	OA	Internally generated bandgap reference voltage 1.22V
2	VCM/ VREF2V5	OA	Common-mode input for OSA and Internally generated 2.5 V reference voltage.
3	VRT	IA	Pixel reset voltage
4	VCDSH	IA	
8	AVO	OA	Analogue Test output
11	ADCbot	IA	Bottom voltage reference for ADC
12	HoldPix	IA	Not for Customer use
13	TopRef	OA	Internally generally top voltage reference for ADC

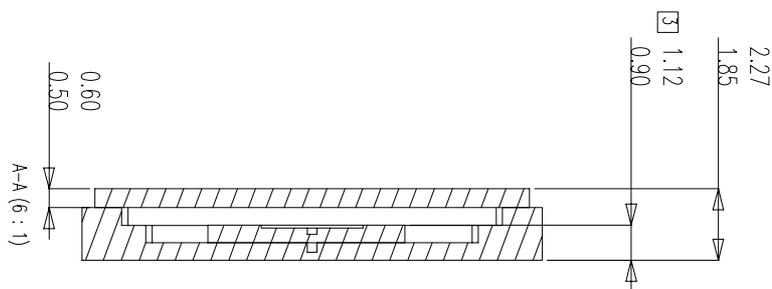
Pin	Name	Type	Description
<b>DIGITAL CONTROL SIGNALS</b>			
18	SCE	ID↓	Test Pin
15	SIN	ID↓	Frame timing reset (soft reset).
16	RESETB	ID↑	System Reset. Active Low.
<b>SERIAL INTERFACE</b>			
42	SCL	ID↑	Serial bus clock (input only).
41	SDA	BI↑	Serial bus data (bidirectional, open drain).
<b>DIGITAL VIDEO INTERFACE</b>			
39 38 35 34	D[3] D[2] D[1] D[0]	ODT	Tristateable 4-wire output data bus. D[3] is the most significant bit.
33	QCK	ODT	Tristateable data qualification clock.
40	FST	ODT	Tristateable Frame start signal.
17	OEB	ID↓	Digital output (tristate) enable.
<b>SYSTEM CLOCKS</b>			
31	CLKI	ID	Oscillator input.
32	CLKO	OD	Oscillator output.

<b>Key</b>			
A	Analogue Input	D	Digital Input
OA	Analogue Output	ID↑	Digital input with internal pull-up
BI	Bidirectional	ID↓	Digital input with internal pull-down
BI↑	Bidirectional with internal pull-up	OD	Digital Output
BI↓	Bidirectional with internal pull-down	ODT	Tristateable Digital Output

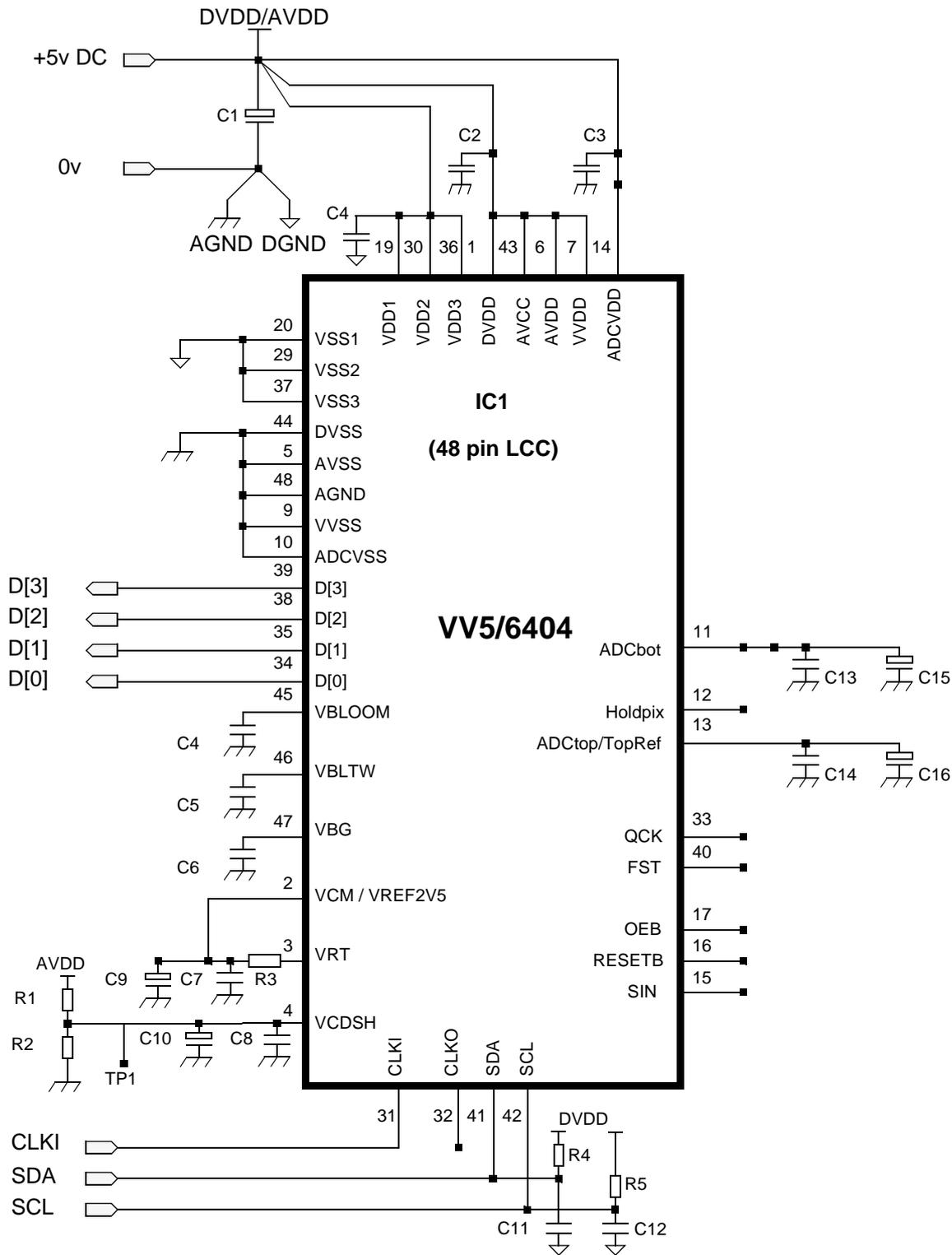
8.3 48LCC Mechanical Dimensions



- Notes:
1. Die is optically centred.
  2. Refractive index of glass is  $\approx 1.52$ .
  3. Distance to optical surface of Die.
  4. Pixel area of sensor.



### 8.4 VV6404 Sensor Support Circuit Schematic Diagram



### 8.5 Sensor Support Circuit Component List

Component	Part No. / Provisional Value	Rating / Notes
IC1	VV6404A	VVL camera chip (48 pin LCC)
C1	10.0 $\mu$ F	6V tant.
C2-C3, C4-C6, C7-C8	0.1 $\mu$ F	
C9-C10	10.0 $\mu$ F	6V tant.
C11-C12	220pF(*)	For 3m cable length
C13-C14	0.1 $\mu$ F	
C15	4.7 $\mu$ F	6V tant
C16	10.0 $\mu$ F	6V tant
	TDB	
R1-R2	Voltage divider such that TP1 = 3.2v	
R3	33 $\Omega$	
R4-R5	2k2 $\Omega$ (*)	For 3m cable length

**Table 33 : PCB Component List**

Notes:

1. Use surface mount components throughout.
2. All ceramic capacitors are type COG.
3. Keep nodes Supply and Ground pins low impedance and independent.
4. Keep circuit components close to chip pins (especially de-coupling capacitors).
5. EMC precautions will be required on D[3:0] if driving a longer cable.

## 9. Ordering Information

Part Number	Description	Defect specification
VV5404C001	CIF resolution monochrome Digital CMOS Image Sensor, 48 pin LCC package	zero defects
VV6404C001	CIF resolution Colour Digital CMOS Image Sensor, 48 pin LCC package	zero defects
VV6404C001-B2	CIF resolution Colour Digital CMOS Image Sensor, 48 pin LCC package	up to 36 defects for use when pixel defect correction is implemented
STV5404E-001	Evaluation Kit for VV5404 sensor	N/A
STV6404E-001	Evaluation Kit for VV6404 sensor	N/A



Information furnished is believed to be accurate and reliable. However, STMicroelectronics assumes no responsibility for the consequences of use of such information nor for any infringement of patents or other rights of third parties which may result from its use. No license is granted by implication or otherwise under any patent or patent rights of STMicroelectronics. Specifications mentioned in this publication are subject to change without notice. This publication supersedes and replaces all information previously supplied. STMicroelectronics products are not authorized for use as critical components in life support devices or systems without express written approval of STMicroelectronics

The ST logo is a registered trademark of STMicroelectronics

© 1999 STMicroelectronics - All Rights Reserved



[www.vvl.co.uk](http://www.vvl.co.uk)

[www.st.com](http://www.st.com)

[asiapacific\\_sales@vvl.co.uk](mailto:asiapacific_sales@vvl.co.uk)  
[central\\_europe\\_sales@vvl.co.uk](mailto:central_europe_sales@vvl.co.uk)  
[france\\_sales@vvl.co.uk](mailto:france_sales@vvl.co.uk)  
[japan\\_sales@vvl.co.uk](mailto:japan_sales@vvl.co.uk)  
[nordic\\_sales@vvl.co.uk](mailto:nordic_sales@vvl.co.uk)  
[southern\\_europe\\_sales@vvl.co.uk](mailto:southern_europe_sales@vvl.co.uk)  
[uk\\_eire\\_sales@vvl.co.uk](mailto:uk_eire_sales@vvl.co.uk)  
[usa\\_sales@vvl.co.uk](mailto:usa_sales@vvl.co.uk)

**VLSI VISION LIMITED**

A company of the ST Microelectronics Group

