

# SX-4475

## LH3 steering sensor with 8° Torque output and single turn Position output.

The LH3 torque and position sensor is ideally suited for demanding Electric Power Steering systems.

### ELECTRICAL<sup>1</sup>

Torque Signal Linearity	±3%
Torque Hysteresis	0.5%
Torque Signal Microgradient	±30% of theoretical slope over 0.4° interval
Torque Signal Sensing Angle	±8°
Position Signal Linearity	±1.5%
Position Signal Microgradient	±30% of theoretical slope over 2° interval
Total Resistance	518 Ω ±30%

### MECHANICAL

Torque Mechanical Travel	±11.4°
Turning Torque (rotor to rotor)	0.03 NM Max.
Turning Torque (position rotor to housing)	0.06 NM Max.
Position Mechanical Travel	Continuous
Weight	grams maximum

### ENVIRONMENTAL

Operating Temperature Range	-40°C to +85°C
Shock	14 ms half-sine at 300 m/s <sup>2</sup>
Vibration	10 to 55 Hz with 1 mm P-P constant displacement, 120 hours each of 3 planes
Torque Rotational Life	1 million cycles
Position Rotational Life	1 million cycles
Storage Temperature Range	-40°C to +105°C

<sup>1</sup> Specifications subject to change without notice.



# SX-4475

## OUTPUT CHARTS

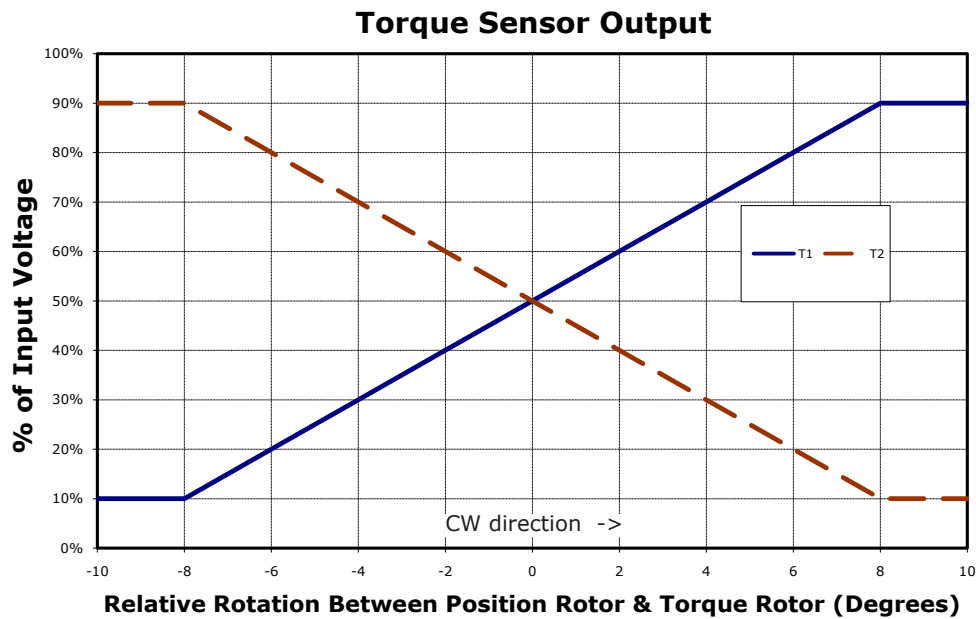
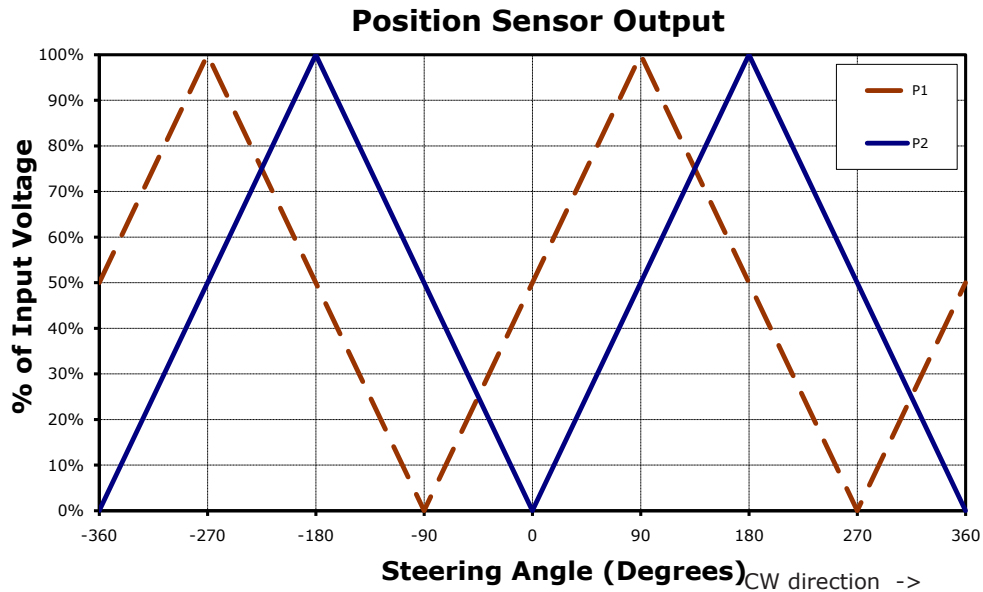

# SX-4475

## OUTLINE DRAWING

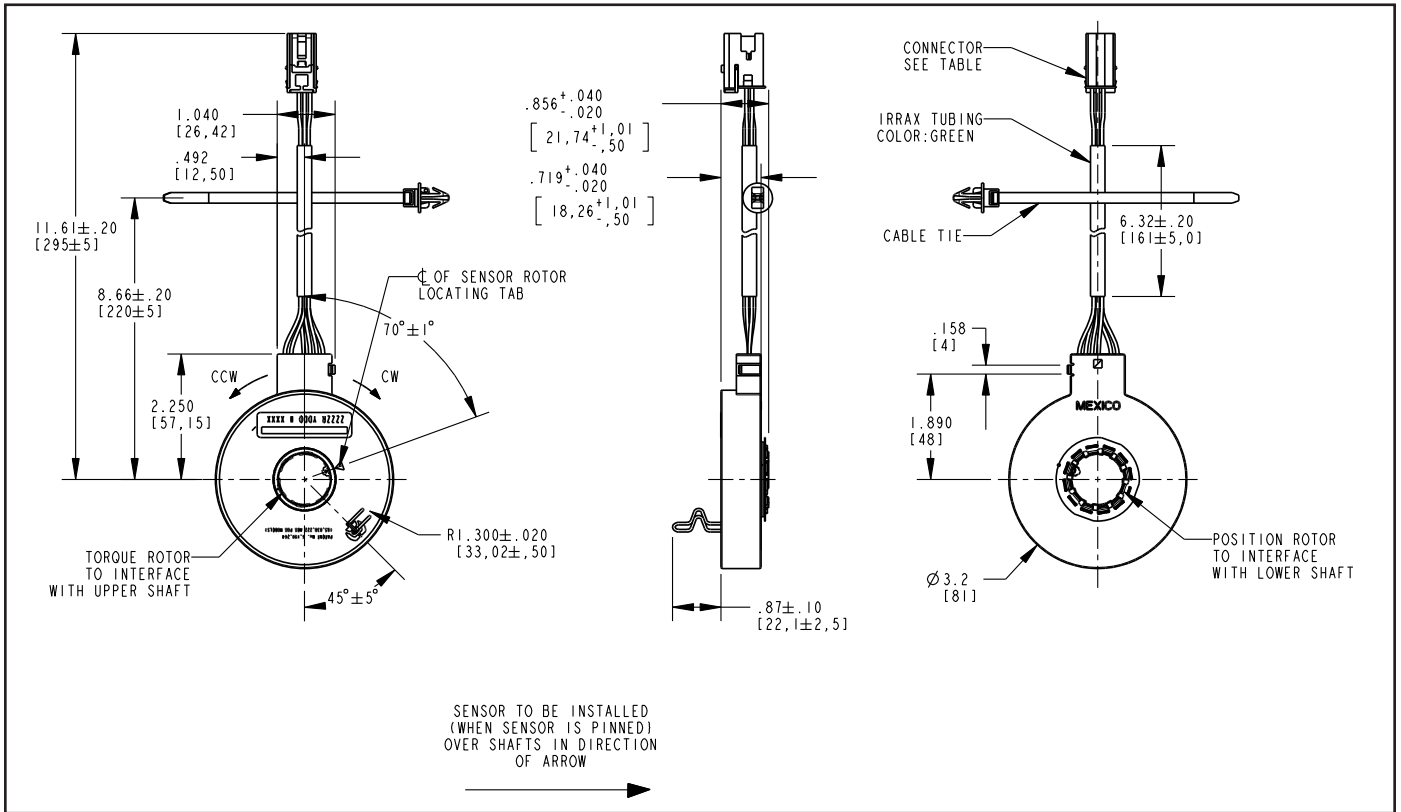

Tolerances ±0.25 mm unless otherwise specified. See drawing # 122-4475-80 for details.

## PINOUTS

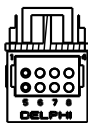

PIN OUTS-8 PIN CONNECTOR			
DELPHI 15406142			
1	2	3	4
5	6	7	8

(PIN No'S ARE INDICATED AS WIRES ENTER CONNECTOR END)

PIN No.	SIGNAL	WIRE COLOR
1	NOT USED	---
2	P1	BROWN
3	Vcc	RED
4	T2	PURPLE
5	NOT USED	---
6	P2	WHITE
7	GND	BLACK
8	T1	BLUE

## BARCODE LABEL

Code 128 symbology

4475 A Y DDD T SSSS

Model #

Last digit of year

Tester #

BI revision letter

Day of year

Sequential serial #

### BI Technologies Corporation

4200 Bonita Place, Fullerton, CA 92835 USA

Phone: 714 447 2345 Website: [www.bitechnologies.com](http://www.bitechnologies.com)

February 2 2015

SX-4475 page 3 of 4

# SX-4475

## RECOMMENDED INTERFACE

