

SX-4479

LH3 steering sensor with 8° Torque output and single turn Position output.

The LH3 torque and position sensor
is ideally suited for demanding
Electric Power Steering systems.

ELECTRICAL¹

Torque Signal Linearity	±3%
Torque Hysteresis	0.5%
Torque Signal Microgradient	±30% of theoretical slope over 0.4° interval
Torque Signal Sensing Angle	±8°
Position Signal Linearity	±1.5%
Position Signal Microgradient	±30% of theoretical slope over 2° interval
Total Resistance	518 Ω ±30%

MECHANICAL

Torque Mechanical Travel	±11.4°
Turning Torque (rotor to rotor)	0.03 NM Max.
Turning Torque (position rotor to housing)	0.06 NM Max.
Position Mechanical Travel	Continuous
Weight	grams maximum

ENVIRONMENTAL

Operating Temperature Range	-40°C to +85°C
Shock	14 ms half-sine at 300 m/s ²
Vibration	10 to 55 Hz with 1 mm P-P constant displacement, 120 hours each of 3 planes
Torque Rotational Life	1 million cycles
Position Rotational Life	1 million cycles
Storage Temperature Range	-40°C to +105°C

¹ Specifications subject to change without notice.



SX-4479

RECOMMENDED INTERFACE

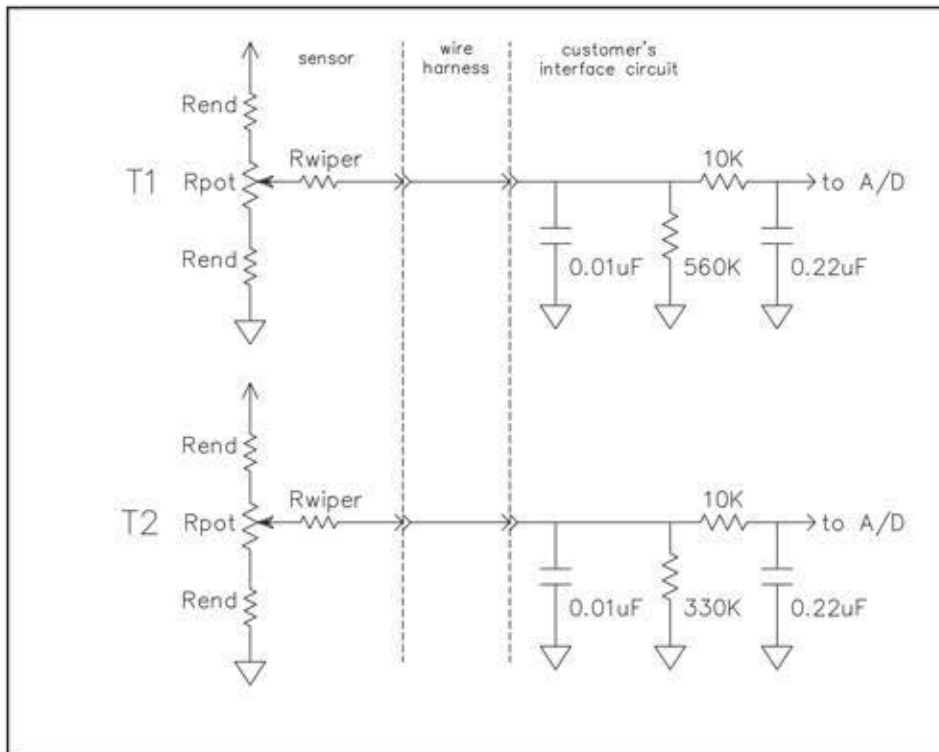
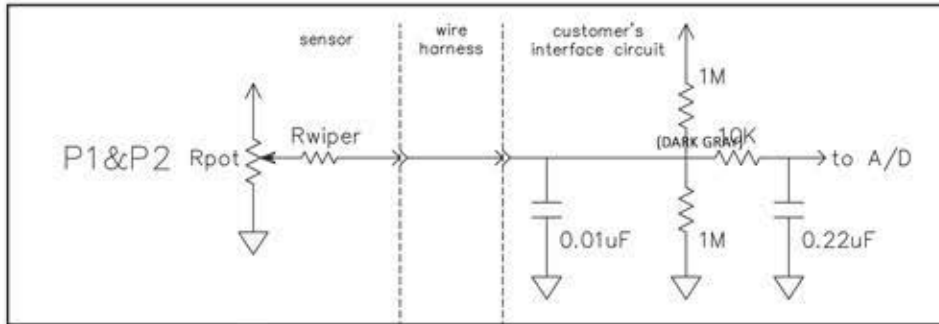

SX-4479

OUTLINE DRAWING

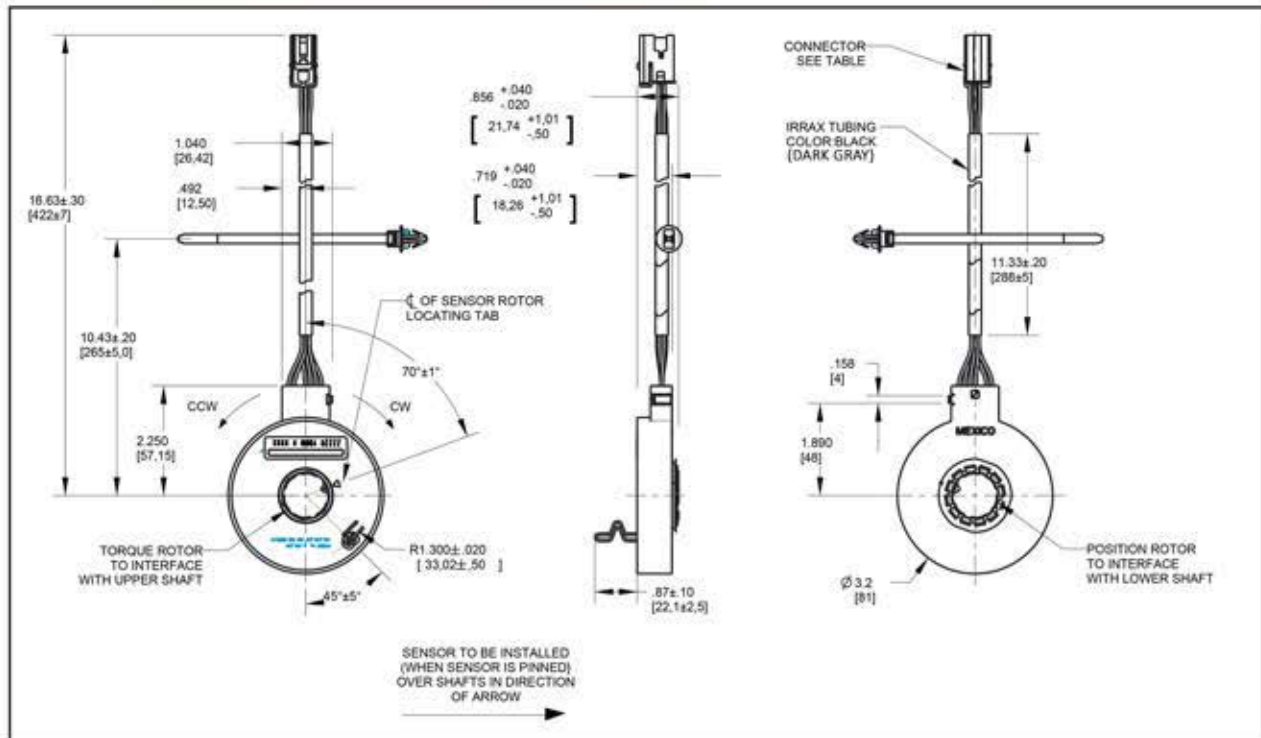

Tolerances ±0.25 mm unless otherwise specified. See drawing # 122-4475-80 for details.

PINOUTS

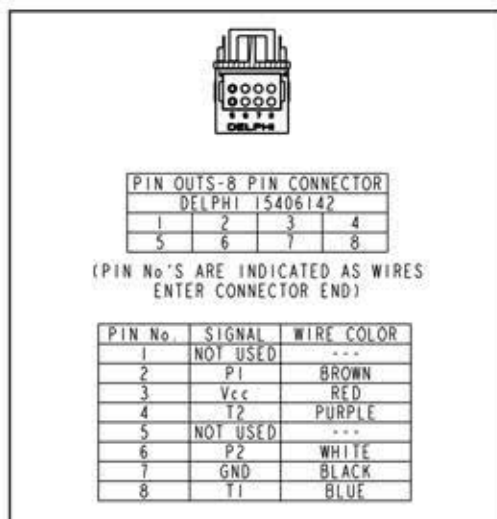

BARCODE LABEL

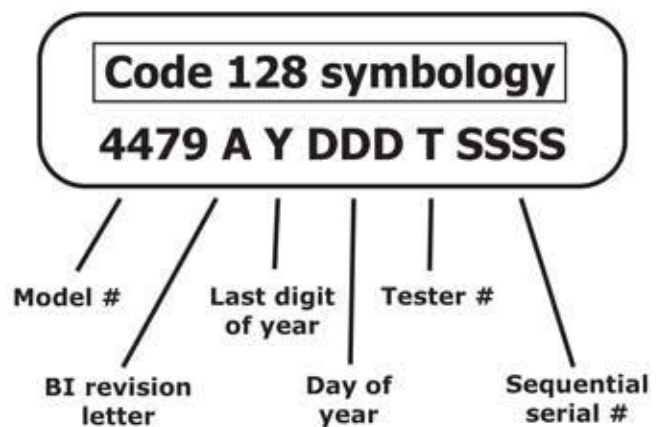

SX-4479

OUTPUT CHARTS

