

SX1230 - Integrated Transmitter IC

Narrow/wideband 315 MHz, 434 MHz 868 MHz and 915 MHz band Transmitter

GENERAL DESCRIPTION

The SX1230 is a fully integrated transmitter which can operate in the 315, 434, 868 and 915 MHz licence free ISM bands.

The transmitter has two modes of operation, a conventional MCU controlled mode and a 'stand-alone' mode which enables the SX1230 to download configuration and messages from an E²PROM in response to a user input.

Stand-alone mode makes the SX1230 ideal for miniaturized or low cost remote keyless entry (RKE) applications. It also offers the unique advantage of narrow-band and wide-band communication in a range of modulation formats.

The SX1230 offers high RF output power and channelized operation suited for the European (ETSI EN 300-220-1), North American (FCC part 15.231, 15.247 and 15.249) and Japanese (ARIB T-67) regulatory standards.

ORDERING INFORMATION

Part Number	Temperature Range	Qty. per Reel	Package
SX1230I066TRT	-40 °C to +85 °C	3000	MLPQ-24 (4x4mm)

APPLICATIONS

- ◆ Remote Keyless Entry (RKE)
- ◆ Remote Control / Security Systems
- ◆ Voice and Data RF Communication Links
- ◆ Process and building / home control
- ◆ Active RFID
- ◆ AMR / AMI Platforms

KEY PRODUCT FEATURES

- ◆ +17 dBm to -18 dBm Programmable output power.
- ◆ Bit rates up to 600 kbits / sec.
- ◆ FSK, GFSK, MSK, GMSK and OOK modulation.
- ◆ Stand-alone mode: No need for a host MCU.
- ◆ Consistent RF performance over a 1.8 to 3.7 V range.
- ◆ Low phase noise (-95 dBc/Hz at 50 kHz) with automated PLL calibration and fully integrated VCO and loop filter.
- ◆ On chip RC timer for timer / wake-up applications.
- ◆ Low battery detection.

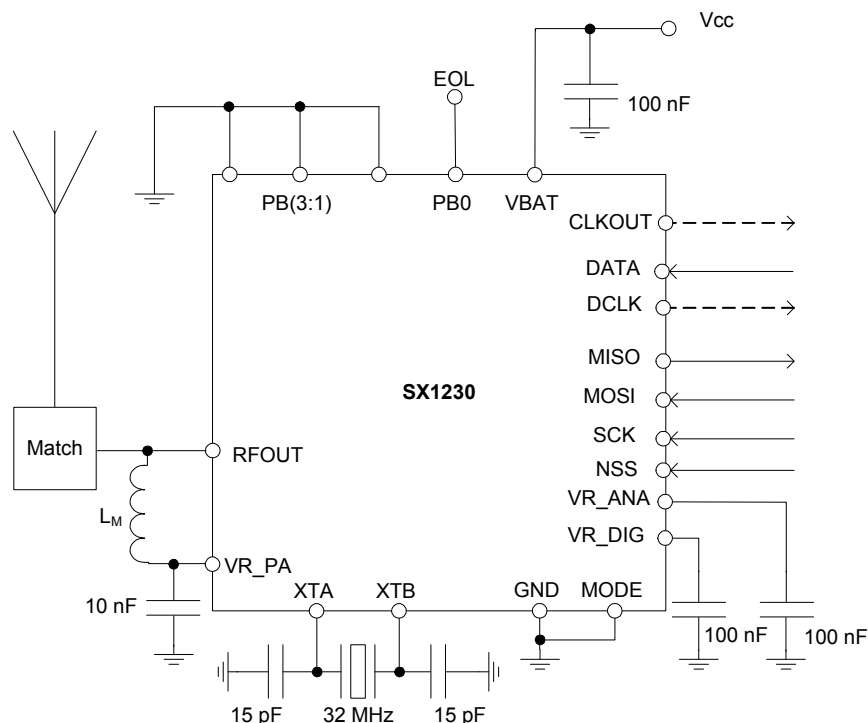

Table of contents

Section	Page
1. General Description	4
1.1. Simplified Block Diagram	4
1.2. Pin Diagram	5
1.3. Pin Description.....	6
2. Electrical Characteristics	7
2.1. ESD Notice	7
2.2. Absolute Maximum Ratings	7
2.3. Operating Range.....	7
2.4. Electrical Specifications.....	8
3. Timing Characteristics	9
4. Working Modes of the SX1230	10
4.1. Operating Modes	10
4.2. Application Modes.....	10
4.2.1. Stand Alone Mode	10
4.2.2. MCU Mode.....	11
5. Operation of the SX1230	12
5.1. Main Parameters.....	12
5.1.1. Center Frequency	12
5.1.2. Frequency Deviation	12
5.1.3. Bit Rate	12
5.2. Synthesizer	13
5.3. The Power Amplifier.....	14
6. Digital Control and Interface	15
6.1. Stand Alone Mode	15
6.1.1. State Machine Description	15
6.1.2. Memory Organization of the E2PROM	15
6.1.3. Periodic mode	17
6.1.4. Low Battery Indicator: Stand Alone Mode.....	18
6.1.5. Low Battery Indicator: MCU Mode	18
6.2. MCU Mode.....	18
6.2.1. SPI Operation	18
6.2.2. Data and Data Clock Usage.....	20
6.3. SX1230 Register Description.....	21
7. SX1230 Application Circuits	27
7.1. SX1230 E2PROM Mode Application Circuit	27
7.2. SX1230 MCU Mode Application Circuit	28
7.3. Complete RKE Application Circuit	28

Table of contents

Section	Page
7.4. Wake-up Times.....	29
7.5. Reset Pin Timing.....	29
7.6. Operation with 17 dBm Output Power.....	31
7.7. Matching for 13 dBm Output Power and Below.....	33
7.8. TCXO Connection.....	34
7.9. PCB Layout Considerations.....	34
8. Reference Design.....	35
9. Reference Design Performance.....	36
9.1. Power Output versus Consumption.....	36
9.2. Power Output Flatness versus Temperature and Supply Voltage.....	37
9.3. Phase Noise.....	38
9.4. SX1230 Baseband Filtering.....	40
9.5. Adjacent Channel Power.....	40
10. Packaging Information.....	43
11. Package Marking.....	43
12. Recommended PCB Land Pattern.....	44
13. Soldering Profile.....	45

This product datasheet contains a detailed description of the SX1230 performance and functionality. Please consult the Semtech website for the latest updates or errata (www.semtech.com).

1. General Description

The SX1230 is a multi-band, single chip transmitter IC capable of (G)FSK, (G)MSK, and OOK modulation of an input data stream. It can transmit this modulated signal in any of the license free ISM bands from 290 MHz to 1020 MHz.

1.1. Simplified Block Diagram

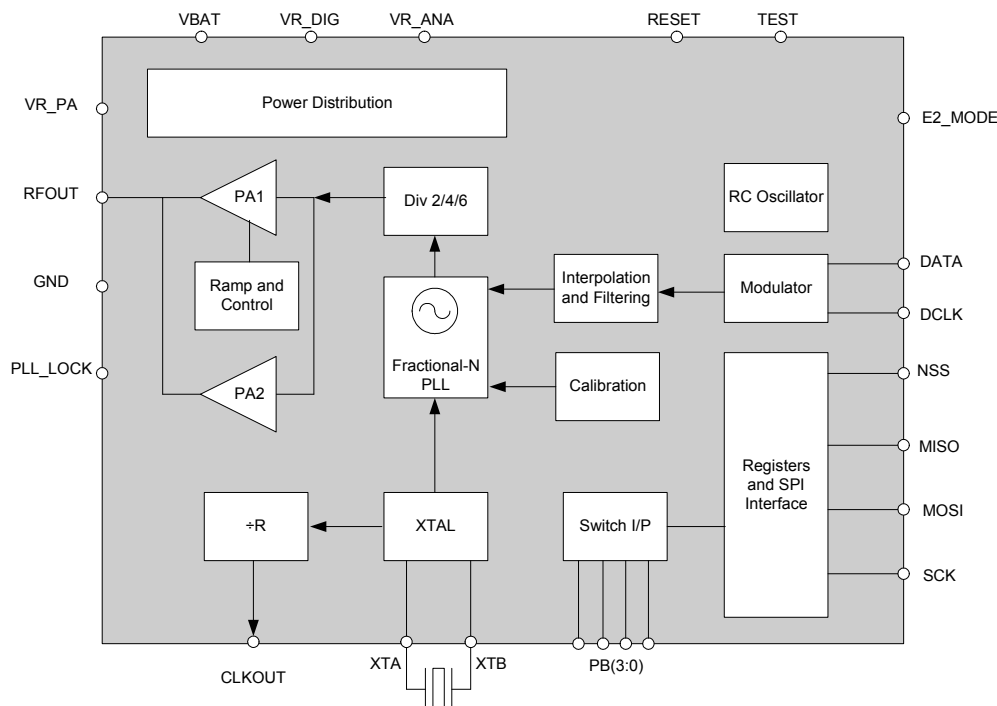

Figure 1. SX1230 Simplified Block Diagram

The general architecture of the SX1230 is shown in Figure 1. The frequency synthesizer generating the LO frequency is a third-order fractional-N sigma-delta PLL. The PLL is capable of fast auto-calibration and offers fast switching and settling times. For frequency modulation ((G)FSK and (G)MSK), the modulation is performed within the PLL bandwidth. Optional pre-filtering of the bit stream may also be enabled to reduce the power delivered to adjacent channels.

Amplitude modulation (OOK), is performed via a DAC driving the reference of the regulator of the PA. Note that pre-filtering of the bit stream is also available in this mode. The VCO works at 2, 4 or 6 times the RF output frequency to improve the quadrature precision and reduce pulling effects during transmission.

The PA of the SX1230 is comprised of two amplifiers - one high power, one low power. This enables the SX1230 to deliver a wide range, over 30 dB, of output powers - up to +13 dBm in single PA configuration. However, with an appropriate output impedance transformation, in dual PA mode, this can be increased to +17 dBm.

The SX1230 also includes two timing references; an RC oscillator, for sleep mode operation of the SPI interface (in MCU mode), and a 32 MHz crystal oscillator, which serves as the low-noise frequency reference of the PLL. The references and supply voltages are provided by the power distribution system which includes several regulators allowing true battery powered operation.

1.2. Pin Diagram

The following diagram shows the pinouts of the 4x4 mm MLPQ-24 package.

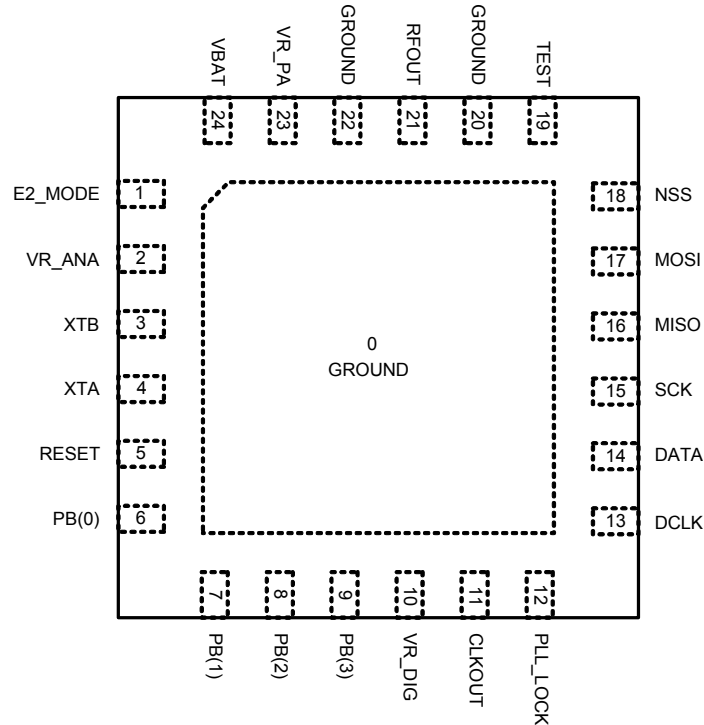

Figure 2. SX1230 Pin diagram (top view)

1.3. Pin Description

Table 1 Description of the SX1230 Pinouts

Number	Name	Type	Description MCU Mode	Description Stand Alone Mode
0	GROUND	-	Global ground (bottom of package)	
1	E2_MODE	I	Mode select '0' = MCU mode	Mode select '1' = Stand alone mode
2	VR_ANA	I/O	Regulated supply voltage for analog circuitry	
3	XTB	I/O	Crystal connection	
4	XTA	I	Crystal connection	
5	RESET	I/O	Reset, active high	
6	PB(0)	I	Low battery indicator output	Push-button input 0, active high
7	PB(1)	I	Connect to GROUND	Push-button input 1, active high
8	PB(2)	I	Connect to GROUND	Push-button input 2, active high
9	PB(3)	I	Connect to GROUND	Push-button input 3, active high
10	VR_DIG	I	Regulated supply for digital circuitry	
11	CLKOUT	O	Reference clock output for MCU	Reference clock output
12	PLL_LOCK	O	PLL lock detection, active high	Transmission of frame OK, active low
13	DCLK	O	Output data clock	NC
14	DATA	I	Modulation input data	NC
15	SCK	I	SPI Clock input	SPI Clock output
16	MISO	I/O	SPI Data output	SPI Data input
17	MOSI	I/O	SPI Data input	SPI Data output
18	NSS	I/O	SPI Chip select input	SPI Chip select output
19	TEST	I	Connect to GROUND	
20	GND	-	RF Ground	
21	RFOUT	O	RF Output	
22	GND	-	RF Ground	
23	VR_PA	I/O	Regulated supply for PA	
24	VBAT	I	Main supply voltage from battery	

2. Electrical Characteristics

2.1. ESD Notice

The SX1230 is an electrostatic discharge sensitive device. It satisfies:

- ◆ Class 1C of the JEDEC standard JESD22-A114-B (human body model) on pins 2, 10, 21 and 23.
- ◆ Class 2 of the JEDEC standard JESD22-A114-B (human body model) on all other pins.



2.2. Absolute Maximum Ratings

Stresses above the values listed below may cause permanent device failure. Exposure to absolute maximum ratings for extended periods may affect device reliability.

Table 2 Absolute Maximum Ratings

Symbol	Description	Min	Max	Unit
VDDmr	Supply Voltage	-0.5	3.9	V
Tmr	Temperature	-55	115	°C

2.3. Operating Range

Operating ranges define the limits for functional operation and the parametric characteristics of the device as described in this section. Functionality outside these limits is not implied.

Table 3 Operating Range

Symbol	Description	Min	Max	Unit
VDDop	Supply voltage	1.8	3.7	V
Top	Operational temperature range	-40	85	°C
Clop	Load capacitance on digital ports	-	25	pF

2.4. Electrical Specifications

The table below gives the electrical specifications of the transmitter under the following conditions: Supply voltage = 3.3 V, temperature = 25 °C, $f_{XOSC} = 32$ MHz, $f_{RF} = 915$ MHz, 2-level FSK modulation without prefiltering, $\Delta f = 5$ kHz, bit rate = 4.8 kbit/s and output power = 13 dBm terminated in a matched 50 ohm impedance, unless otherwise specified.

Table 4 Transmitter Specifications

Symbol	Description	Conditions	Min	Typ	Max	Unit	
Current Consumption							
IDDSL	Supply current in sleep mode		-	0.5	1	µA	
IDDST	Supply current in standby mode	Crystal oscillator enabled	-	0.9	1.2	mA	
IDDFS	Supply current in synthesiser mode		-	8	-	mA	
IDDT	Supply current in transmit mode with appropriate external matching (see Section 7).	RF Power o/p = 17 dBm	-	95	-	mA	
		RF Power o/p = 13 dBm	-	45	-	mA	
		RF Power o/p = 10 dBm	-	33	40	mA	
		RF Power o/p = 0 dBm	-	20	25	mA	
RF and Baseband Specifications							
BRF	Bit rate, FSK	Programmable.	1.2	-	600	kbps	
BRO	Bit rate, OOK	Programmable.	1.2	-	32	kbps	
FDA	Frequency deviation, FSK	Programmable	0.6	-	300	kHz	
RFOP	RF output power in 50 ohms	Programmable with 1 dB steps.	Max	10	13	-	dBm
			Min	-21	-18	-	dBm
PHN	Transmitter phase noise	50 kHz Offset from carrier	-	-95	-	dBc/Hz	
RFOPH	Max RF output power with an external impedance transformation	With external match to 50 ohms.	14	17	-	dBm	
ACP	Transmitter adjacent channel power (measured at 25 kHz offset)	Pre-filter enabled. Measurement conditions as defined by EN 300 220-1 V2.1.1.	-	-	-37	dBm	
FR	Synthesizer Frequency Range	Programmable.	FBand 1	290	-	340	MHz
			FBand 2	431	-	510	MHz
			FBand 3	862	-	1020	MHz
FSTEP	Frequency synthesizer step	$FXOSC/2^{19}$	-	61	-	Hz	
FRC	RC Oscillator frequency range		45	65	85	kHz	
Timing Specifications							
TS_FS	Frequency synthesizer wake up time	Crystal oscillator Enabled.	-	100	150	µs	

Symbol	Description	Conditions	Min	Typ	Max	Unit
TS_TR	Transmitter wake-up time	Frequency synthesizer enabled. Note, depends upon bit rate and ramp time, please refer to Section 7.4.	-	120	-	μs
TS_OS	Crystal oscillator wake-up time		-	300	500	μs
FXOSC	Crystal oscillator frequency		26	32	32	MHz
TS_TT	Total Wake up time	Sleep to transmit, automated. Note, depends upon bit rate and ramp time, please refer to Section 7.4.	-	450	-	μs
T_DATA	Data set-up time		-	-	0.25	μs

3. Timing Characteristics

The following table gives the operating specifications for the SPI interface of the SX1230.

Table 5 SPI Timing Specifications

Symbol	Description	Conditions	Min	Typ	Max	Unit
f_{SCK}	SCK Frequency		-	-	10	MHz
t_{ch}	SCK High time		50	-	-	ns
t_{cl}	SCK Low time		50	-	-	ns
t_{rise}	SCK rise time		-	5	-	ns
t_{fall}	SCK Fall time		-	5	-	ns
t_{setup}	MOSI Setup time	From MOSI transition to SCK rising edge	30	-	-	ns
t_{hold}	MOSI hold time	From SCK rising edge to MOSI transition	20	-	-	ns
t_{nl}	NSS setup time	From NSS falling edge to SCK rising edge	30	-	-	ns
$t_{nh,n}$	NSS Hold time	From SCK falling edge to NSS rising edge.	30	-	-	ns

For explanatory diagrams of the timing characteristic parameters, please see Figure 7 and Figure 8.

4. Working Modes of the SX1230

4.1. Operating Modes

The four operating modes of the SX1230 are shown in Table 6. Each of these may be selected via the SPI bus by writing the corresponding bits to Mode(2:0). A key feature of the SX1230 is that the transition from one operating mode to the next is automatically optimized. For example, if the transmit operating mode is selected whilst in sleep operating mode then, in a pre-defined time-optimized sequence, each of the intermediate modes is engaged sequentially without the need to issue any further SPI commands. For more information on timing and optimization please see Section 7.4.

Table 6 SX1230 Operating Modes

MODE(2:0)	Selected Mode	Enabled Blocks				
		RC Osc	SPI	Xtal Osc	Freq. Synth.	PA
000	Sleep mode	Optional	x			
001	Stand-by mode	Optional	x	x		
010	FS mode	Optional	x	x	x	
011	Transmit mode	Optional	x	x	x	x

4.2. Application Modes

The SX1230 has two application modes, selected by applying an external logical level to the E2_MODE input (pin 6). The first, MCU mode (E2_Mode= '0'), configures the SX1230 as an SPI slave. This permits the configuration of the circuit by an external microprocessor via the SPI interface of the SX1230 and the data to be applied via the DATA input (pin 14). The second application mode, stand-alone mode (E2_Mode = 0), sees the SX1230 configured as SPI master. In the stand-alone application mode the SX1230 can download its configuration from an external SPI E²PROM. Moreover, in response to an input on the GPIO pins, a specific configuration can be programmed and a payload transmitted.

Note that this mode selection process is performed at start up (or POR) of the circuit. Thus the hardware mode cannot be dynamically changed without resetting the chip. This may be achieved either by power down or by issuing an active high POR signal to the Reset input (pin 5). For reset signal timing please see the diagram of Figure 13 and accompanying description.

4.2.1. Stand Alone Mode

In stand alone mode (E2_Mode = '1') the SX1230 will operate as a stand-alone SPI master which can download both register settings and data payload from an SPI E²PROM. Four debounced GPIO inputs are available in stand alone mode, in this application mode the SX1230 remains in sleep operating mode until either a single or combination of button presses are detected. SX1230 can then be dynamically reconfigured and / or transmit a data sequence stored within the E²PROM.

The SX1230 can accommodate SPI E²PROM sizes up to 8 kbit and uses industry standard SPI commands. For a full description of E²PROM use with SX1230 and the associated application circuits, please see Section 6.1. The application circuit for stand-alone operation is shown in Figure 3, note that both matching and L_M are band specific whilst C_{TX} is application specific.

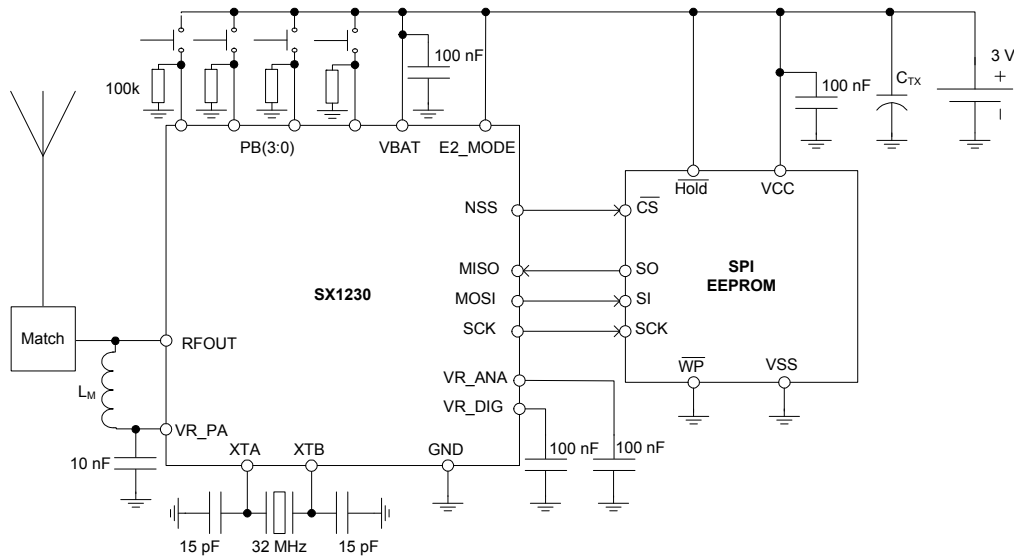

Figure 3. SX1230 Stand-Alone Application Circuit

4.2.2. MCU Mode

The SX1230 is also capable of operating in a conventional MCU controlled mode. Figure 4 shows the SX1230 operating in MCU mode and connected to an external microcontroller. Note that CLKOUT provides the oscillator signal for the MCU, thus negating the need for two crystal oscillators. The DCLK connection is also optional - only being required if the data rate is to be determined by SX1230 or transmit filtering is to be used.

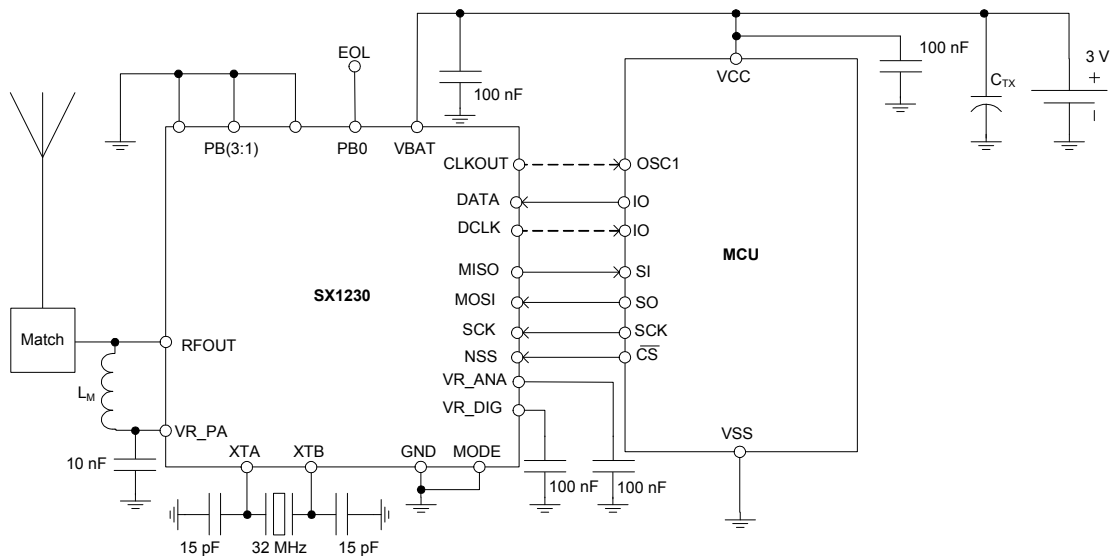

Figure 4. SX1230 MCU Mode Application Circuit

5. Operation of the SX1230

The SX1230 is an integrated ISM band transmitter and features a fully integrated frequency synthesizer, modulator and power amplifier. This section describes the operation of the SX1230 and the functionality of these blocks.

5.1. Main Parameters

5.1.1. Center Frequency

The carrier output center frequency, f_{RF} , of the SX1230 is programmable via the SPI interface. It is determined by the following equation:

$$f_{RF} = \frac{\text{freq_rf}(23:0) \cdot f_{XOSC}}{2^{19}}$$

where $\text{freq_rf}(23:0)$ is the decimal value of the 24 bit number stored in configuration registers FrfMsb, FrfMid and FrfLsb and f_{XOSC} is the frequency of the crystal oscillator. If the optimal value of 32 MHz is selected for the crystal oscillator, then this results in a programmable frequency resolution of 61.035 Hz.

Note that RF output frequencies are only valid in the bands 290-340 MHz, 431-510 MHz and 862-1020 MHz. Note also, that for ease of use, the band selection process is performed automatically.

5.1.2. Frequency Deviation

The frequency deviation of the SX1230 in FSK mode is given by the following equation:

$$\Delta f = \frac{f_{XOSC} \cdot \text{df_coeff}(13:0)}{2^{19}}$$

where df_coeff is the decimal value of the 14 bit contents of the FdevLsb and FdevMsb configuration registers.

5.1.3. Bit Rate

The bit rate (or, depending upon coding, the chip rate) of the SX1230 is given by the following equation:

$$R_B = \frac{f_{XOSC}}{\text{br_ratio}(15:0)}$$

where f_{XOSC} is the crystal oscillator frequency, br_ratio is the decimal value of the 16 bit contents of registers BrMsb and BrLsb. Note that for OOK modulation the maximum bit rate is 32.7 kbps which corresponds to a $\text{br_ratio}(15:0)$ of 979.

The table below gives examples of some of the standard data rates accessible with SX1230.

Table 7 Example Standard Bitrates and their Corresponding Register Settings.

Type	BrMSB	BrLSB	(G)FSK, (G)MSK	OOK	Rb Actual (to 7s.f.)
Classical modem baud rates (multiples of 1.2 kbps)	0x68	0x2B	1.2 kbps	1.2 kbps	1200.015
	0x34	0x15	2.4 kbps	2.4 kbps	2400.060
	0x1A	0x0B	4.8 kbps	4.8 kbps	4799.760
	0x0D	0x05	9.6 kbps	9.6 kbps	9600.960
	0x06	0x83	19.2 kbps	19.2 kbps	19196.16
	0x03	0x41	38.4 kbps		38415.36
	0x01	0xA1	76.8 kbps		76738.60
	0x00	0xD0	153.6 kbps		153846.1
Classical modem baud rates (multiples of 0.9 kbps)	0x02	0x2C	57.6 kbps		57553.95
	0x01	0x16	115.2 kbps		115107.9
Round bit rates (multiples of 12.5, 25 and 50 kbps)	0x0A	0x00	12.5 kbps	12.5 kbps	12500.00
	0x05	0x00	25 kbps	25 kbps	25000.00
	0x80	0x00	50 kbps		50000.00
	0x01	0x40	100 kbps		100000.0
	0x00	0xD5	150 kbps		150234.7
	0x00	0xA0	200 kbps		200000.0
	0x00	0x80	250 kbps		250000.0
	0x00	0x6B	300 kbps		299065.4
Watch Xtal frequency	0x03	0xD1	32.768 kbps	32.768 kbps	32753.32

5.2. Synthesizer

The frequency synthesizer of the SX1230 is a fully integrated fractional-N third-order sigma-delta phase-locked loop and VCO. Also incorporated are fully integrated third-order and low pass filters which determine the loop bandwidth. All of these features are fully automated and derived from the user bitrate and frequency deviation settings, as described in Sections 5.1.1 to 5.1.3.

To ensure the frequency accuracy of the PLL output it is necessary to perform calibration. The calibration process is performed automatically upon power up of the SX1230. However, the calibration feature is also accessible to the user via the SPI configuration register, PllStat (address 0x0A). The calibration is performed by setting bit 2 (pll_cal) high. This ensures that the frequency output accuracy is limited only by the frequency error of the crystal oscillator, the calibration procedure lasts 500 μ s, during which time pll_cal_done (bit 4 of address 0x0A) is set low. Once complete pll_cal_done is set high and confirmation of a successful calibration can be obtained by reading pll_cal_ok.

5.3. The Power Amplifier

A simplified schematic of the dual power amplifiers of the SX1230 is shown in Figure 5. PA 1 comprises a pair of amplifiers: One dedicated for low power use, LPA, for programmed powers from -18 to -3 dBm: The second for high power use, HPA, for programmed powers from -2 to 13 dBm. PA 2 is a single high power amplifier and may be used in conjunction with PA 1 to deliver the full 17 dBm of output power.

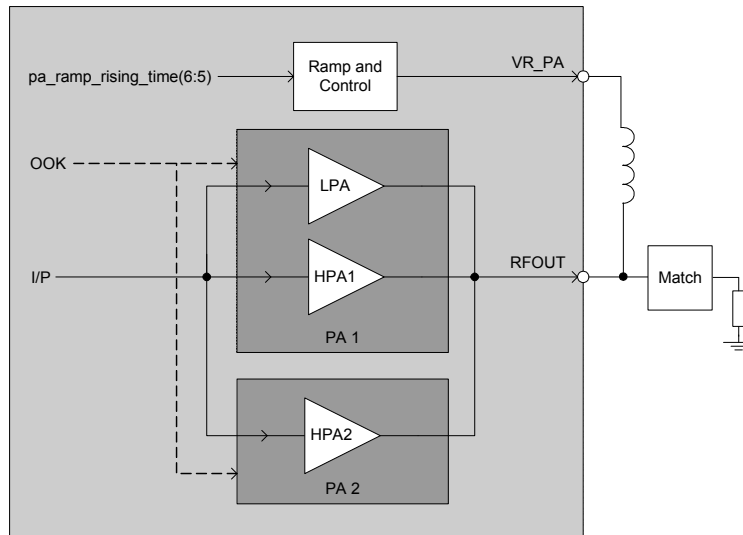

Figure 5. Simplified Schematic of the SX1230 Power Amplifier

The mode of operation of the PA's is determined by the register setting `pa_select(1:0)` which is configured as shown in Table 8, below. The output power of the PA is determined by the value of the register `pow_val(4:0)`, with a single PA enabled the output power is set by:

$$P_{out} = -18 \text{ dBm} + \text{pow_val}(4:0)$$

The default setting for this register is 13 dBm. The expressions for the output power with other combinations of power amplifier enabled are shown in Table 8. Note also that the power amplifier current limiter, over current protection (OCP), feature of SX1230 can also limit the output power. To ensure correct operation at 17 dBm ensure that `trim_ocp(3:0)` is set to 105 mA ('1100').

Table 8 Power Amplifier Mode Selection Truth Table

pa_select(1:0)	Mode	Power Range	Pout Formula
00	invalid	-	
01	PA1 enabled	-18 to 13 dBm	-18 dBm + pow_val(4:0)
10	PA2 enabled	-	-
11	Dual PA	-13 to 17 dBm	-13 dBm + pow_val(4:0)

The ramp and power control features of the PA, determine the regulator output voltage which is used to power the amplifiers, this must be done through an external RF choke.

6. Digital Control and Interface

The SX1230 has several operating modes, configuration parameters and internal status indicators which are stored in internal registers. In MCU mode, all of these registers can be accessed by an external microcontroller via the SPI interface. In stand alone mode, both the configuration information and the data to be transmitted, are stored in an external E²PROM. The way that both the configuration and payload information is stored in the E²PROM must match the way the configuration is defined in the internal registers. For a full description see Section 6.1.2.

6.1. Stand Alone Mode

6.1.1. State Machine Description

The stand alone mode is activated when the pin E2_Mode is tied to VDD. The SX1230 SPI interface is then configured in master mode. The internal state machine of the SX1230 then carries out the following operations:

- 1) Immediately after power-up, the SPI interface reads the main configuration section in the E²PROM and then goes into the 'sleep' operating mode (i.e. all blocks off).
- 2) Whilst in 'sleep' operating mode, when an edge is detected on any of the push-buttons PB[3:0], the chip wakes-up and starts the RC oscillator (typical startup time ~100 μ s).
- 3) The RC oscillator is used to clock a debounce timer which gives the logical push button input value after the programmed delay. The frame section corresponding to the button value (1 to 15) is read from the E²PROM. At this point additional, button specific, configuration information may be loaded. Otherwise, the configuration settings of 1) are used. Using the appropriate configuration, the payload corresponding to the detected button press is then transmitted. The payload transmission may be repeated up to 254 times.
- 4) When the frame has been transmitted, the pad PLL_LOCK goes low and the chip goes into SLEEP mode.

6.1.2. Memory Organization of the E²PROM

The memory map for stand alone mode is shown in Figure 6. The configuration information occupies the first 77 bytes, the format of the configuration is {ADDR; VALUE} - therefore allowing up to 38 registers to be defined. Each push button configuration is mapped directly to a location in the E²PROM - determined by the mappings given in Table 9 and the variable section_size(5:0). The purpose of this variable, push button specific, section size is to allow the optimum use of different sizes of external memory. Note that the maximum frame length is 64 bytes - this equates to a maximum E²PROM size of 8 kbit. The influence of the section_size variable is illustrated in Figure 6.

The mapping of Table 9 permits up to 15 frames to be defined. Each section may contain both write_registers commands and the payload to be transmitted. Thus allowing the dynamic configuration of settings such as output power and frequency in response to a button push. Each section within the E²PROM must conform to the following format: {FIFO_ADDR; REPEAT; LENGTH; VALUE_1; VALUE_2;...;VALUE_N}. Where VALUE_1... N is the user defined payload, REPEAT is the number of times the frame is to be transmitted, LENGTH defines the number of bytes in the message and FIFO_ADDR = 0x95.

The push-buttons may need to be debounced before being read. The debouncer time constant is programmed by the debounce_time(2:0) register which allows a range of debounce timer values to be accessed from 470 μ s to 480 ms. An

option for no debouncing is also available. Note that time constants are process and temperature dependent and may vary by +/- 15%.

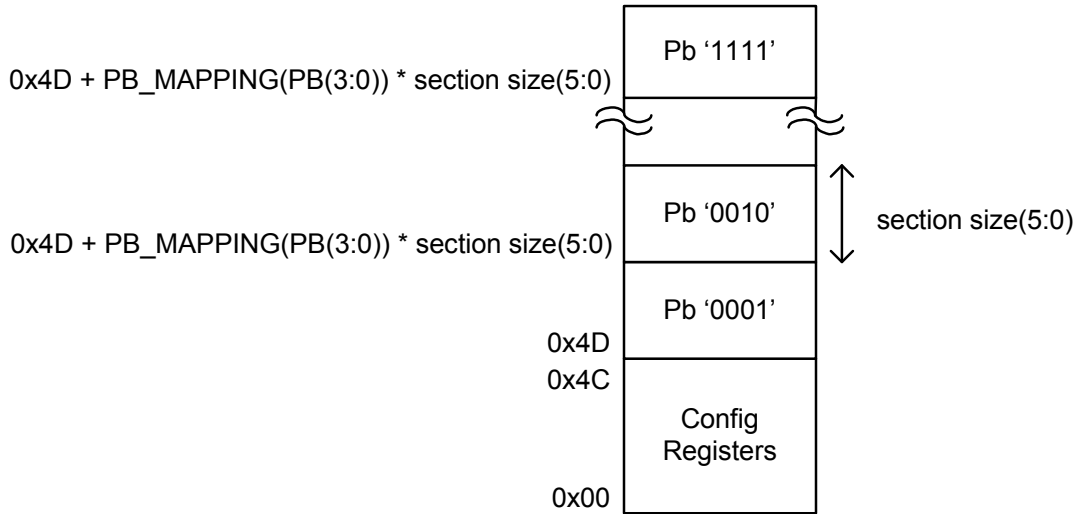

Figure 6. Memory Mapping in Stand Alone Mode

The table below gives the push button mappings for the determination of E²PROM memory locations. Note that the combinations PB[3:0] = '0001', '0010', '0100' and '1000' are mapped to the four lowest locations in memory. This mapping allows the use of a simple four button interface with the minimum memory size.

Table 9 Push Button Combination to E²PROM Memory Location Mapping

PB[3:0]	PB_MAPPING(3:0)	PB[3:0]	PB_MAPPING(3:0)
0000	None (no active push-button)	1000	3
0001	0	1001	7
0010	1	1010	8
0011	4	1011	11
0100	2	1100	9
0101	5	1101	12
0110	6	1110	13
0111	10	1111	14 / Low Battery

The commands in the E²PROM are written as instructions thus bit 7 is set high - equivalent to adding 0x80 to the register address to be programmed. As was shown in Figure 6, the first 77 bytes are used for configuration. Note that registers only require programming if they hold a value other than the default value (see table 11 for default register settings).

The following table gives an example snippet of E²PROM contents, here for each location in E²PROM memory the first 13 bytes of the available 77 (0x4C) bytes are occupied with configuration. The remaining bytes are left in their default 0xFF setting. The first push-button memory location is at 0x4D. Here we see that the periodic mode timer (see following section for a full description) is configured and a 10 byte payload follows. Subsequent push buttons are configured at the locations determined by the section size, see Figure 6.

Table 10 Example External SPI E2PROM Contents for SX1230 Configuration

Address	Content	Comment	Address	Content	Comment
0x00	0x81	Start-up config. (address)	0x4C	0xFF	Empty
0x01	0x05	Start-up config. (data)	0x4D	0x97	PB[0] config (address)
0x02	0x82	Start-up config. (address)	0x4E	0x00	PB[0] config (data)
0x03	0x00	Start-up config. (data)	0x4F	0x95	FIFO address
0x04	0x83	Start-up config. (address)	0x50	0x0A	Repeat
0x05	0x03	Start-up config. (data)	0x51	0x0A	Length
0x06	0x84	Start-up config. (address)	0x52	0x55	Start of PB[0] Payload
0x07	0x33	Start-up config. (data)	0x53	0x55	PB[0] Payload: Byte 1
0x08	0x85	Start-up config. (address)	0x54	0x55	PB[0] Payload: Byte 2
0x09	0xE3	Start-up config. (data)	0x55	0x55	PB[0] Payload: Byte 3
0x0A	0x90	Start-up config. (address)	0x56	0xAA	PB[0] Payload: Byte 4
0x0B	0x0F	Start-up config. (data)	0x57	0x0A	PB[0] Payload: Byte 5
0x0C	0x93	Start-up config. (address)	0x58	0x0B	PB[0] Payload: Byte 6
0x0D	0x1C	Start-up config. (data)	0x59	0x0C	PB[0] Payload: Byte 7
0x0E	0xFF	Empty	0x5A	0x20	PB[0] Payload: Byte 8
0x0F	0xFF	Empty	0x5B	0x00	PB[0] Payload: Byte 9
0x10-0x4B	0xFF	0x10 to 0x4B Empty	0x5C	0x97	PB[1] config (address)

Subsequent button push button configuration and payload could follow at address 0x5C, respecting the E²PROM section size constraint. Note that if register 0x00 is configured, care should be taken to enable transmit mode - mode(2:0) to ensure reliable transition to transmit mode.

6.1.3. Periodic mode

Periodic mode is a sub-mode of stand alone mode wherein the SX1230 will periodically sense the push button inputs for activity. If a push button input is high then the payload according to that input is transmitted. The wake-up interval, $T_{wake-up}$, is defined by periodic_n(3:0) and periodic_d(3:0) values.

$$T_{wake-up} = 2 \cdot T_{RC} \cdot (\text{periodic_n}(3:0) + 1) \cdot 2^{\text{periodic_d}(3:0) + 9}$$

where T_{RC} is the RC oscillator period, `periodic_n` is programmable between 0 and 15 and `periodic_d` may take values between 0 and 10. The maximum period is hence approximately 125 s when the frequency of the RC oscillator is 67 kHz.

Push button mode is enabled when the value of `D` is non-zero and, when activated, all stand alone mode functionality is available. It is important to note that if there is no push button pressed, then no message will be transmitted.

6.1.4. Low Battery Indicator: Stand Alone Mode

The low battery indicator may be used in stand alone mode to detect the battery voltage and send a low battery message to the receiver. It is enabled by setting the `eol_frame_mode` bit 'high' (register 0x12). The low battery state is determined by comparing the supply voltage with a 1.695 V to 2.185 V programmable threshold (`threshold_trim_eol(2:0)`, address 0x12). Following detection, the following actions are performed depending upon the exact mode of operation:

Normal Operation (Non-Periodic): The battery end-of-life condition is checked during the normal frame. If it is true, then a single extra frame #14 (see Table 9) is automatically sent after the normal frame.

Stand-Alone Periodic Mode Operation: The battery end-of-life condition is checked during the normal frame. If it is true, then the next frame, sent at the next timer tick is frame #14 (see Table 9), the frame is sent only once.

6.1.5. Low Battery Indicator: MCU Mode

In MCU mode the low battery status indicator may be accessed and configured via the SPI register `EolCtrl`. Alternatively, the active high low battery indication is mapped to the `PB0` pin allowing the independent generation of hardware interrupts.

6.2. MCU Mode

6.2.1. SPI Operation

The first byte in any data transfer over the SPI is the address read/write byte. It comprises:

1. W/RB bit, which is 1 for write access and 0 for read access
2. 7 bits of address, MSB first.

A transfer always starts by the `NSS` (not slave select) signal going low whilst `SCK` is high. `MOSI` (master out - slave in) is generated by the master on the next falling edge of `SCK` and is sampled by the slave on the next rising edge of `SCK`. `MISO` is generated by the slave on the falling edge of `SCK` and is high impedance when `NSS` is high. By convention, all bytes are sent MSB first.

MCU mode is activated when pad `E2_Mode` is tied to GND (ground). In this mode the SX1230 is configured as SPI slave and its internal configuration registers can be written following the format shown in Figure 7.

An 'address write-byte' followed by a data byte is sent for a write access. Where multiple sequential registers are to be written, the `NSS` input may be kept low after this first address-byte plus data-byte have been sent. In this state sequential data-bytes may be written, the address is automatically incremented after the reception of each additional data-byte. This allows the sequential data-bytes to be written without the need for an address byte. `NSS` must then be set 'high' after the last byte transfer.

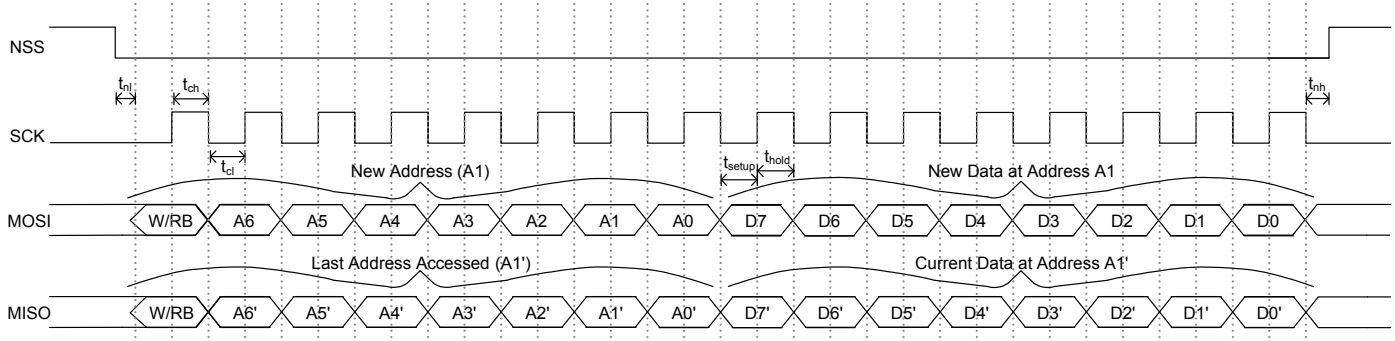

Figure 7. Register Write Access

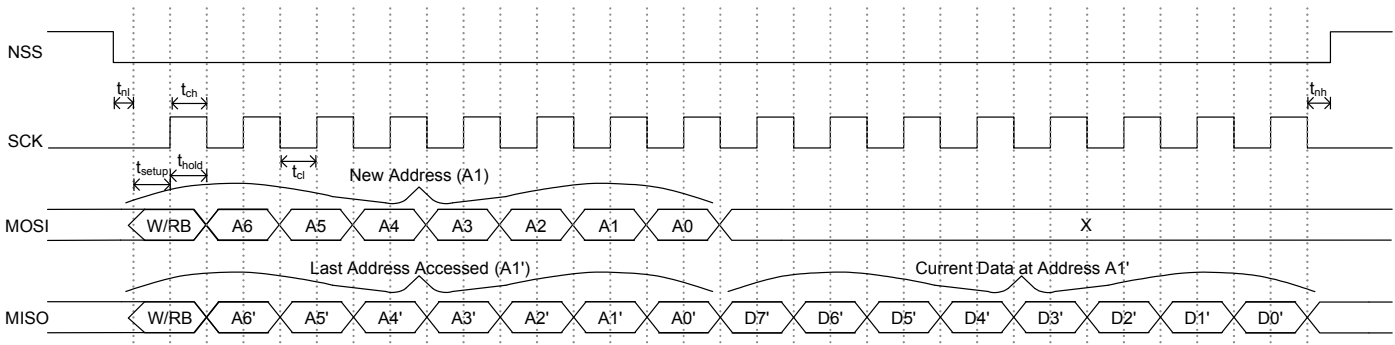

Figure 8. Register Read Access

Similarly, the configuration registers of the SX1230 can be read by issuing an 'address read-byte' (see Figure 8) the corresponding register contents are then transferred over the MISO line. As above, the contents of each subsequent register can be transferred by holding the NSS input low.

A summary of all of the registers of the SX1230 are given in Table 11, this is followed by detailed descriptions of each of the registers in Table 12.

6.2.2. Data and Data Clock Usage

In MCU mode the data to be transmitted is applied exclusively via the DATA input. The DATA input is sampled at the crystal frequency, f_{xosc} . Where the MCU mediates the data rate and no gaussian or bit filtering is required, then the use of the data clock signal is optional. However, where filtering is to be used or the specified data rate accuracy is to be achieved, then the rising edge of the data clock, DCLK, signal must be used to clock the data into the SX1230 DATA input.

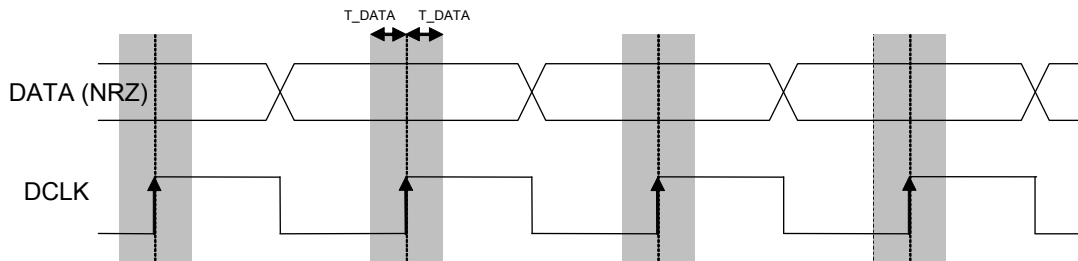

Figure 9. SX1230 Data Clock Timing Diagram (Used Only for Filtering and Ensuring Bit Rate Accuracies)

6.3. SX1230 Register Description

Table 11 SX1230 Register Summary

Address	Register Name	Description
0x00	Mode	Operating and modulation mode settings.
0x01	BrMsb	Bit rate setting.
0x02	BrLsb	
0x03	FdevMsb	Frequency Deviation (FSK).
0x04	FdevLsb	
0x05	FrMsb	RF centre frequency setting.
0x06	FrMid	
0x07	FrLsb	
0x08	PaCtrl	PA selection and power control.
0x09	PaFskRamp	PA rise and fall timing (FSK).
0x0A	PlIStat	PLL status register.
0x0B	VcoCtrl1	VCO calibration values.
0x0C	VcoCtrl2	
0x0D	VcoCtrl3	
0x0E	VcoCtrl4	
0x0F	ClockCtrl	Clock output pin settings.
0x10	Eeprom	Stand alone mode E ² PROM configuration.
0x11	ClockSel	Selection between RC or crystal oscillator.
0x12	EolCtrl	Low battery indicator settings.
0x13	PaOcpCtrl	PA Over current protection - limits PA current.
0x14	unused	-
0x15	unused	-
0x16	unused	-
0x17	PerDivider	Periodic mode wake-up timer control.
0x18	BtnDeb	Push button debouncer setting.

Table 12 SX1230 SPI Register Description

Addr.	Register Name	Default	Bits	Variable Name	Mode	Description
0x00	Mode	0x10	7	-	rw	unused
			6:4	mode(2:0)	rw	Operating mode: 000 sleep mode (SLEEP) 001 stand-by mode (STDBY) 010 frequency synthesizer mode (FS) 011 transmit mode (TX) others reserved Read value is always chip actual mode
			3:2	modul_type(1:0)	rw	Modulation type: 00 FSK 01 OOK Others reserved
			1:0	data_shaping(1:0)	rw	Data shaping: In FSK: 00 no shaping 01 Gaussian filter with BT = 1.0 10 Gaussian filter with BT = 0.5 11 Gaussian filter with BT = 0.3 In OOK: 00 no shaping 01 filtering with fcutoff = bit rate 10 filtering with fcutoff = 2 * bit rate (BR <= 32 kb/s) 11 reserved
0x01	BrMsb	0x1A	7:0	br_ratio(15:8)	rw	Bit rate MSB (chip rate if Manchester encoding)
0x02	BrLsb	0x0B	7:0	br_ratio(7:0)	rw	Bit rate LSB (chip rate if Manchester encoding) $R_B = \frac{f_{XOSC}}{br_ratio(15:0)}$ Default value is 0x1A0B = 4.8 kbps
0x03	FdevMsb	0x00	7:6	-	-	unused
			5:0	fdev_coeff(13:8)	rw	Deviation frequency MSB
0x04	FdevLsb	0x52	7:0	fdev_coeff(7:0)	rw	Deviation Frequency LSB $\Delta f = \frac{f_{XOSC} \cdot df_coeff(13:0)}{2^{19}}$ Default = 0x0052 = 82, gives 5 kHz
0x05	FrMsb	0xE4	7:0	freq_rf(23:16)	rw	RF carrier frequency MSB
0x06	FrMid	0xC0	7:0	freq_rf(15:8)	rw	RF carrier centre bits

Addr.	Register Name	Default	Bits	Variable Name	Mode	Description
0x07	FrfLsb	0x00	7:0	freq_rf(7:0)	rw	RF carrier frequency LSB $f_{RF} = \frac{\text{freq_rf}(23:0) \cdot f_{XOSC}}{2^{19}}$ For $f_{XOSC} = 32$ MHz, resolution = 61.035 Hz Default = 0xE4C000, gives 915 MHz
0x08	PaCtrl	0x3F	7	-	r	unused
			6:5	pa_select	rw	Selects between PA1 and PA2 00 = unused 01 = PA1 selected (d) 10 = reserved 11 = PA1 and PA2 selected.
			4:0	pow_val(4:0)	rw	Output power Pout = -18 dBm + pow_val Default is 13 dBm.
0x09	PaFskRamp	0x08	7:4	-	r	unused
			3:0	pa_ramp_rising_time(3:0)	rw	Rise/fall time ramping (FSK only) 0000 = 2 ms 0001 = 1 ms 0010 = 500 us 0011 = 250 us 0100 = 125 us 0101 = 100 us 0110 = 62 us 0111 = 50 us 1000 = 40 us (d) 1001 = 31 us 1011 = 25 us 1010 = 20 us 1100 = 15 us 1101 = 12 us 1110 = 10 us 1111 = 8 us

Addr.	Register Name	Default	Bits	Variable Name	Mode	Description
0x0A	PllStat	0x10	7:6	-	r	unused
			5	pll_lock_detect	r	PLL lock status: 0 = PLL not locked 1 = PLL locked
			4	pll_cal_done	r	PLL calibration status 0 = Calibration on-going 1 = Calibration performed Note: Reset to 0 in sleep mode irrespective of calibration state.
			3	pll_cal_ok	r	PLL Calibration Result 0 = Calibration procedure failed 1 = Calibration procedure successful Note: Reset to 0 in sleep mode irrespective of calibration state
			2	pll_cal_start	w	Triggers PLL calibration, always read as 0.
			1:0	pll_divr(1:0)	rw	PLL division ratio 00 = Automatic Others, PLL divider = PLL_divr
0x0B	VcoCtrl1	NA	7:5	-	r	unused
			4:0	SB1(4:0)	rw	VCO band first calibration value
0x0C	VcoCtrl2	NA	7:5	-	r	unused
			4:0	SB2(4:0)	rw	VCO band second calibration value
0x0D	VcoCtrl3	NA	7:5	-	r	unused
			4:0	SB3(4:0)	rw	VCO band third calibration value
0x0E	VcoCtrl4	NA	7:5	-	r	unused
			4:0	SB4(4:0)	rw	VCO band fourth calibration value
0x0F	ClockCtrl	0x05	7:4	-	r	unused
			3	rc_enable	rw	Enables RC oscillator. RC oscillator is also automatically switched on in E ² PROM mode. 0 = RC oscillator off 1 = RC oscillator on
			2:0	clkout_select	rw	Selects CLKOUT source: 000 = f_{XOSC} (32 MHz) 001 = $f_{XOSC} / 2$ (16 MHz) 010 = $f_{XOSC} / 4$ (8 MHz) 011 = $f_{XOSC} / 8$ (4 MHz) 100 = $f_{XOSC} / 16$ (2 MHz) 101 = $f_{XOSC} / 32$ (1 MHz) (d) 110 = RC clock (65 kHz) 111 = Clock output off. Note: Switching from RC to f_{XOSC} or vice versa can generate glitches

Addr.	Register Name	Default	Bits	Variable Name	Mode	Description
0x10	Eeprom	0x10	7:6	-	-	unused
			5:0	section_size(5:0)	rw	Section size, used in E ² PROM mode only.
0x11	ClockSel	0x11	7:5	-	r	unused
			4	xosc_ck_ext_sel	rw	Selects external clock instead of xosc 0 = use xosc 1 = use external clock
			3:0	-	r/w	unused
0x12	EolCtrl	0x12	7:5	-	r	unused
			4	q_eol	r	Battery end of life flag 0 = VBAT < VTHR (Battery is flat) 1 = VBAT > VTHR
			3	on_eol	rw	Enables EOL 0 = EOL disabled 1 = EOL enabled
			2:0	vthr_eol(2:0)	rw	Battery end of life threshold 000 = 1.695 V 001 = 1.764 V 010 = 1.835 V (default setting) 011 = 1.905 V 100 = 1.976 V 101 = 2.045 V 110 = 2.116 V 111 = 2.185 V
0x13	PaOcpCtrl	0x11	7:5	-	r	unused
			4	on_ocp	rw	Enables power amplifier current limiter: 0 = OCP disabled 1 = OCP enabled
			3:0	trim_ocp(3:0)	rw	PA OCP DC load current threshold: 0000 = 45 mA 0001 = 50 mA 0010 = 55 mA 0011 = 60 mA 0100 = 65 mA 0101 = 70 mA 0110 = 75 mA 0111 = 80 mA 1000 = 85 mA 1001 = 90 mA 1010 = 95 mA 1011 = 100 mA (default setting) 1100 = 105 mA (recommended +17 dBm setting) 1101 = 110 mA 1110 = 115 mA 1111 = 120 mA
0x14	Unused	-	-	-	-	unused

Addr.	Register Name	Default	Bits	Variable Name	Mode	Description
0x15	Unused	-	-	-	-	-
0x16	Unused	-	-	-	-	unused
0x17	PerDivider	0x00	7:4	periodic_d(3:0)	rw	Periodic mode D divider (values from 1 to 10)
			3:0	periodic_n(3:0)	rw	Periodic mode N divider (values from 0 to 15) $T_{wake} = 2T_{RC}(\text{periodic_n}(3:0) + 1) \cdot 2^{\text{periodic_d}(3:0) + 9}$ Note: Only available in E ² PROM Mode and when N>0 (N = 0 = disabled)
0x18	BtnDeb	0x03	7:3	-	r	unused
			2:0	debounce_time(2:0)	rw	Push button debounce tim constant: 000 = 470 us 001 = 7.5 ms 010 = 15 ms 011 = 30 ms (d) 100 = 60 ms 101 = 120 ms 110 = 240 ms 111 = 480 ms

7. SX1230 Application Circuits

7.1. SX1230 E²PROM Mode Application Circuit

Figure 10 shows the standard E²PROM connection for stand alone mode operation of the SX1230. With a preconfigured E²PROM (see Section 6.1 for a full description of operation) upon connection of the battery to this circuit the SX1230 reads the configuration section of the E²PROM then sends itself into sleep mode. Both devices remain in sleep mode until a key-press is detected.

Once a key is pressed the SX1230 wakes up and starts the RC oscillator. After a user defined wait period, to allow debouncing and determined by `debounce_time(2:0)`, the frame corresponding to the button press is read and transmitted. Once the transmission is complete, both the SX1230 and the E²PROM return to their sleep mode configuration. For the corresponding receiver application circuit please see Figure 12.

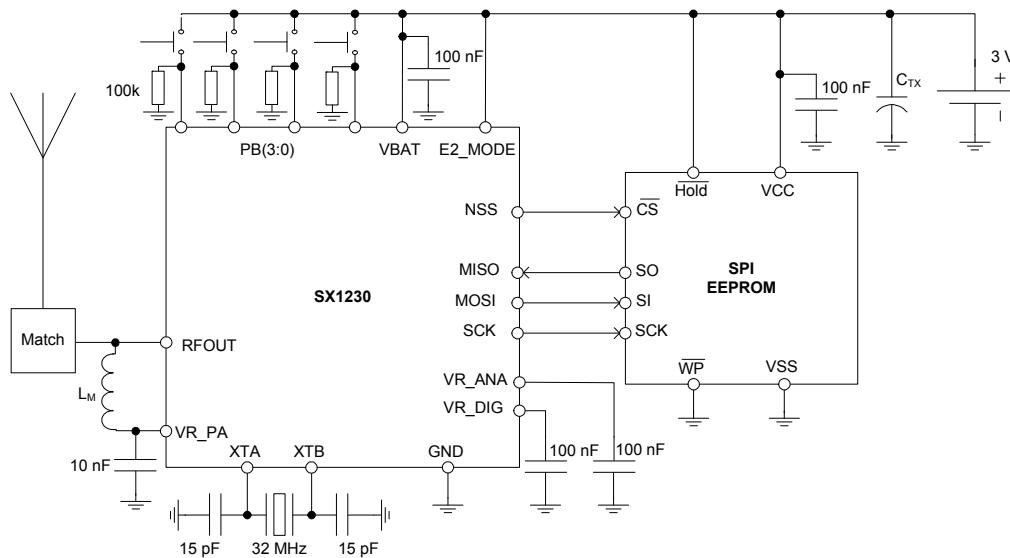

Figure 10. The SX1230 Stand-Alone Mode Application Circuit

7.2. SX1230 MCU Mode Application Circuit

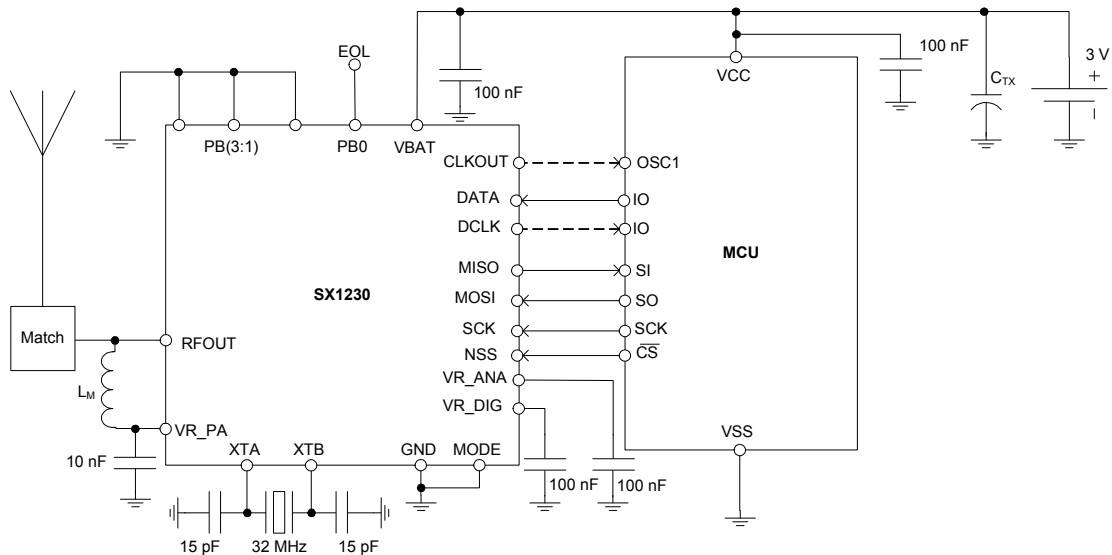

Figure 11. Interfacing the SX1230 to an MCU

Figure 11 shows conventional MCU mode configuration of the SX1230 - here the interface to the SX1230 is performed using 5 MCU pins. In this mode the MCU acts as SPI master exercising total control of the SX1230. For further economy the MCU clock may be driven using the clock output of the SX1230 which can provide several fractions of the crystal oscillator frequency from the fundamental to 1/32 depending upon the setting of `clkout_select(2:0)`.

7.3. Complete RKE Application Circuit

Compatible Semtech receivers for RKE applications are the SX1213 (315 and 434 MHz bands) and the SX1210 (868 and 915 MHz ISM bands), the application circuit for which is shown in the proceeding figure. With both transmitter and receiver configured for wide-band operation, (frequency deviation of 150 kHz), and both devices employing crystals with 50ppm frequency stability, the worst case frequency error between Tx and Rx is 31.5 kHz.

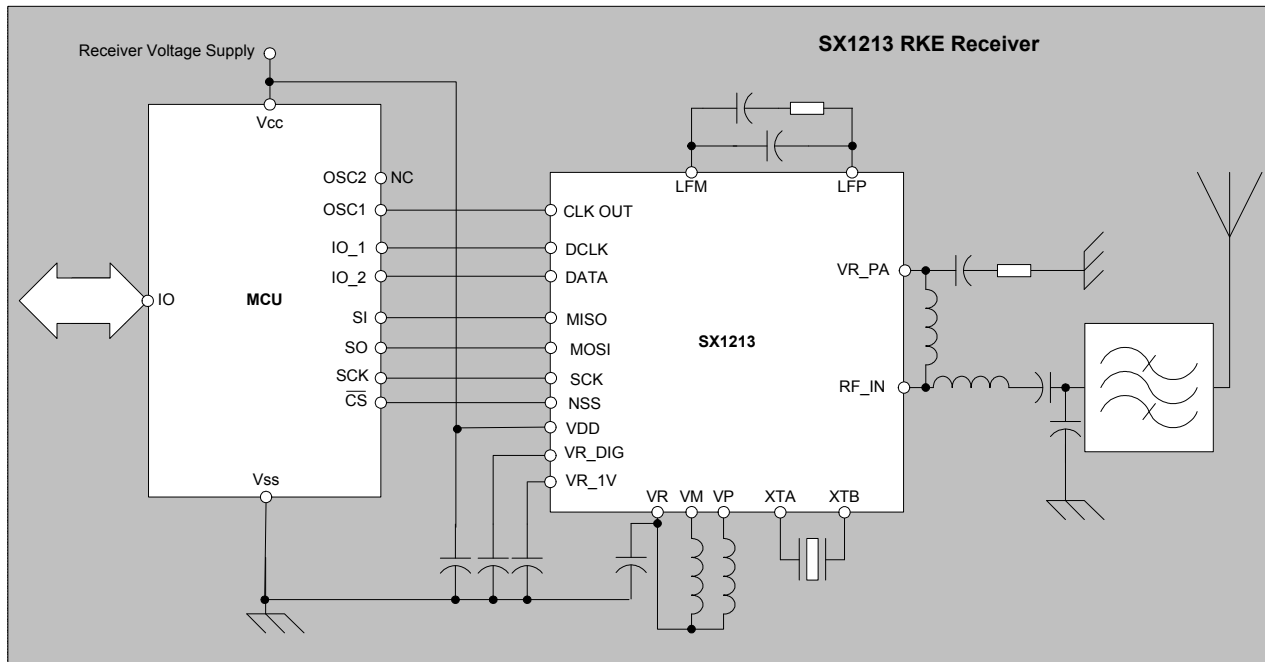

Figure 12. SX1213 RKE Demonstration Receiver

7.4. Wake-up Times

When switching between modes, an optimized sequence of events is automatically performed by SX1230. For example, in response to the command to enter transmit mode whilst in sleep mode, each intermediate mode is engaged - ensuring crystal oscillator start-up and PLL lock before transition to transmit mode. External indication of PLL lock is given by the PLL lock pin (MCU mode only). The PLL lock pin output is only valid whilst no data is applied to the DATA pin. The transition from frequency synthesizer mode to transmit is well defined and a function of bit rate and transmit ramp time, given in FSK mode by:

$$TS(\mu s) = 5 + 1.25 \cdot pa_ramp_rising_time(3:0) + \frac{1}{2 \cdot R_B}$$

where $pa_ramp_rising_time(3:0)$ is the user defined contents of PaFskRamp and R_B is the bit rate. For OOK mode the time is given by:

$$TS_TS(\mu s) = 5 + \frac{1}{2 \cdot R_B}$$

A flow chart showing the automatic, optimised start-up procedure, initiated with a single SPI command is shown in Figure 14. Note that after the PLL lock indicator is set then the transmitter requires TS_TR to set-up before transmission may begin.

7.5. Reset Pin Timing

Manual reset of the SX1230 is possible by asserting a logical high to the reset pin. The timing for this operation is shown in the following figure. During the reset operation the SX1230 current consumption may rise to 1 mA. Following the reset operation the user must wait 5 ms before performing any other operation.

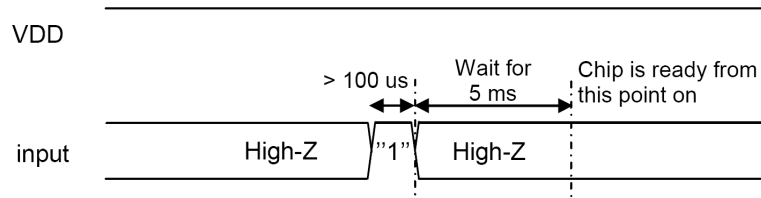

Figure 13. SX1230 Reset

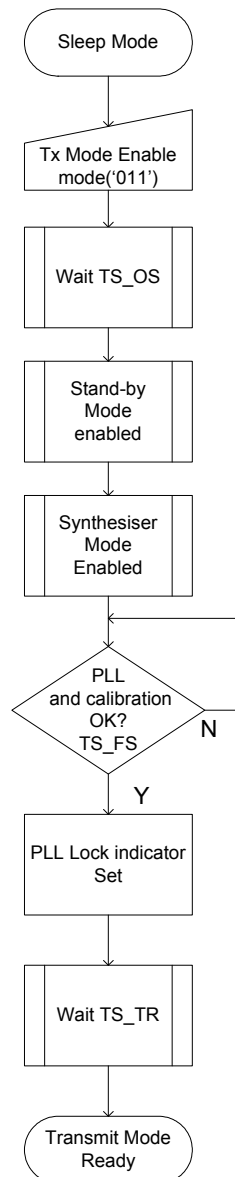

Figure 14. Automatic Optimised SX1230 Start-up Sequence with a Single SPI Command

7.6. Operation with 17 dBm Output Power

With both power amplifiers enabled the SX1230 can generate a 17 dBm (50 mW) output. Starting with the default power amplifier configuration, the register changes necessary to avail of the full output power are:

- ◆ The over current protection limiter (OCP) through which the PA is biased must be increased to 100 mA.
- ◆ Both PA1 and PA 2 must be enabled.
- ◆ A programmed power output (pow_val) must be set to 13 dBm.

The ideal matching network for full regulatory compliance with FCC Part 15 for 915 MHz operation is shown in Figure 15 where, in addition to matching, is an additional discrete notch filter for harmonic rejection.

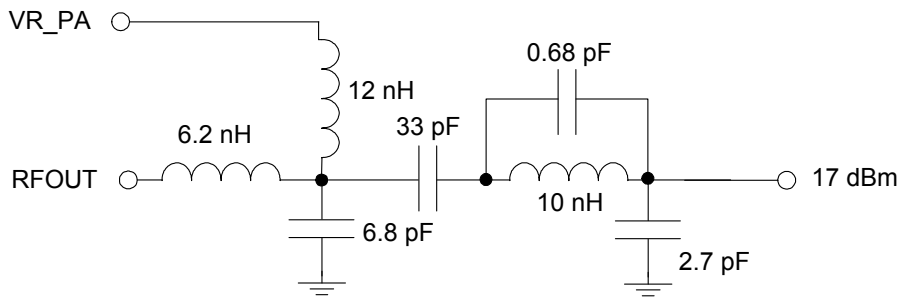

Figure 15. Single 17 dBm Matching Circuit for both 902-928 MHz (FCC) and 868 MHz (ETSI) Compliance

Figures 9 and 10 show the circuit diagrams of the 434 MHz ETSI and 315 MHz FCC compliant matching schemes. Although the full power may not necessarily be availed of in these bands, 17 dBm operation can permit the use of lower gain, electrically small antennas.

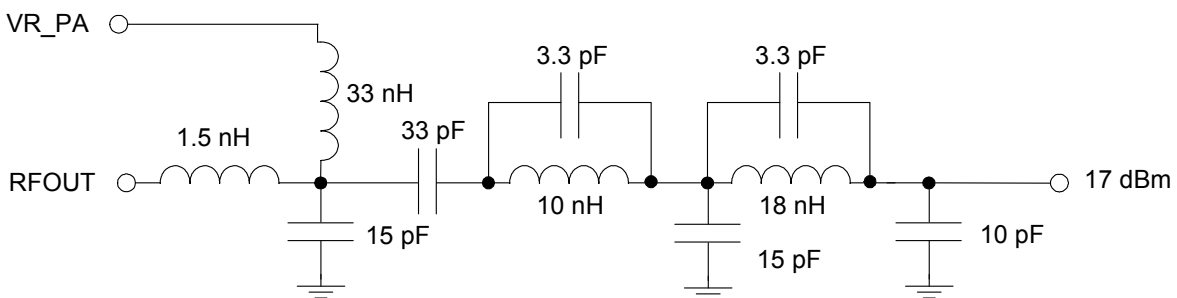

Figure 16. Output Matching for 17 dBm Output Power in the 434 MHz Band

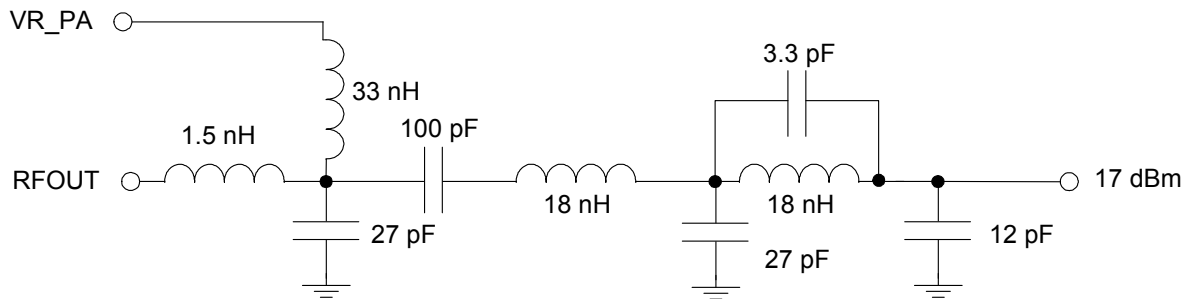

Figure 17. Output Matching for 17 dBm Output Power in the 315 MHz Band

The following table shows typical measured power values for the harmonics of the fundamental using each of the three matching schemes above. Note that the harmonic levels are in full compliance with the regulations appropriate to each band with substantial margin.

Table 13 Typical Harmonic Levels Measured in 30 kHz Bandwidth using the +17 dBm Matching Circuits.

Harmonic	Pout 315 MHz (dBm)	Pout 434 MHz (dBm)	Pout 868 MHz (dBm)	Pout 915 MHz (dBm)
H1	17.1	17.4	16.4	17.1
H2	-49	-50	-40.7	<-52.8
H3	-49	-44	<-52.8	<-52.8
H4	-48	-43	-49.8	-47.38
H5	-50	-40	-45.3	<-52.8

7.7. Matching for 13 dBm Output Power and Below

For operation at or below 13 dBm of output power, the matching configuration of the following figures is recommended for use in the 915 MHz, 868 MHz and 434/351 MHz bands respectively. Whilst the 17 dBm matching of the preceding section can be used, the adoption of the following matching configurations will guarantee that the current consumption in transmit mode is optimized.

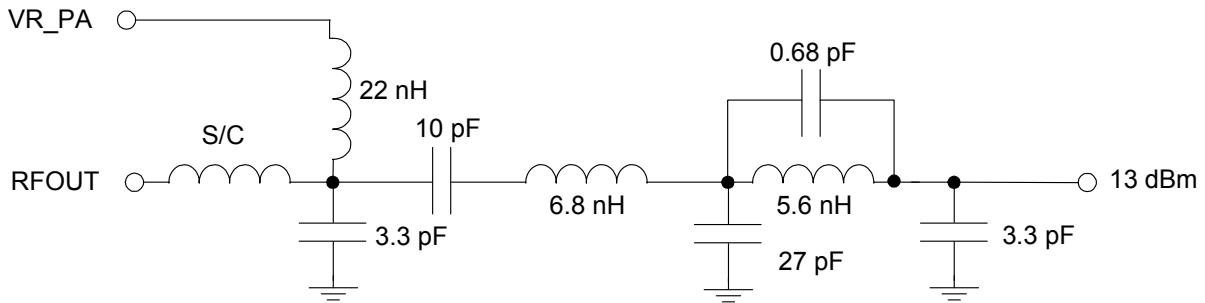

Figure 18. Consumption Optimized Matching for 915 MHz operation at or below 13 dBm Output Power

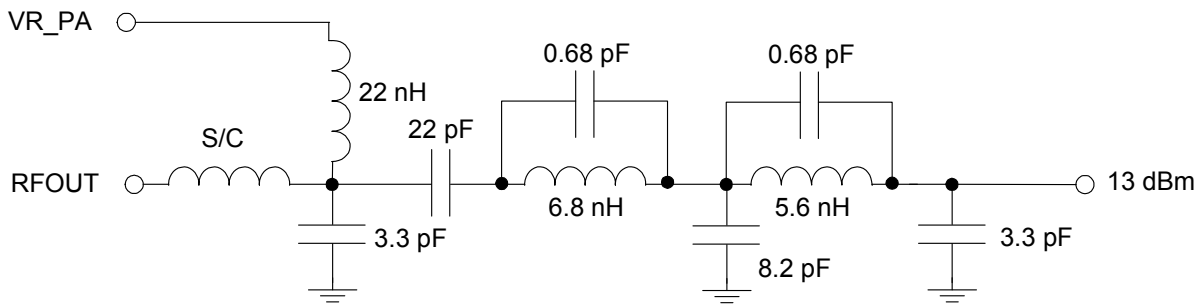

Figure 19. Consumption Optimized Matching for 868 MHz Operation at or below 13 dBm Output Power

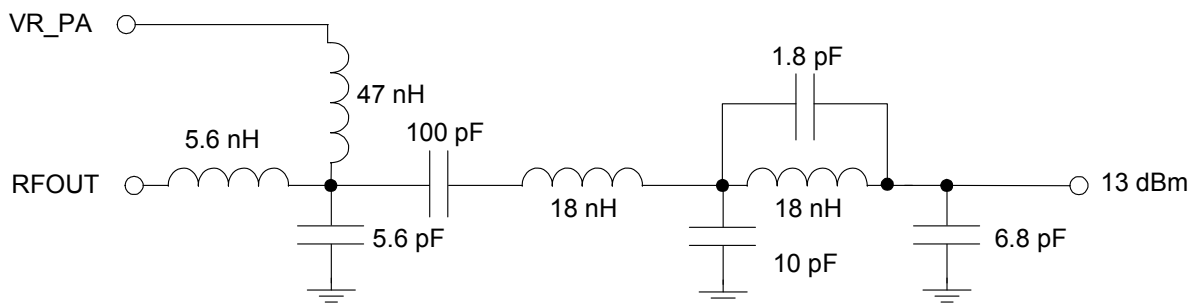

Figure 20. Consumption Optimized Matching for 315/434 MHz Operation at or below 13 dBm Output Power

7.8. TCXO Connection

The frequency accuracy of the SX1230 is dependent upon the precision of the frequency reference from which the RF output is derived. For applications where high frequency accuracy or stability is required, such as narrow band or licensed band applications, the connection of a temperature compensated crystal oscillator (TCXO) is possible. The SX1230 allows the direct connection of a 1.8 V, clipped sine type TCXO to the XTA input. The connection is shown in Figure 21, please consult your TCXO supplier for an appropriate value of decoupling capacitor, C_D .

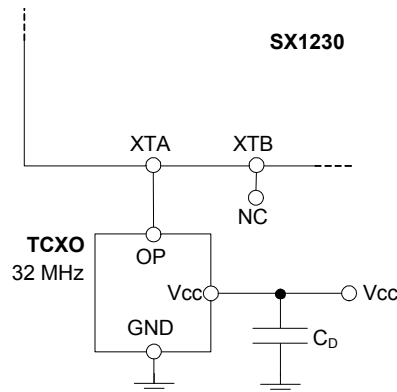

Figure 21. Direct TCXO Connection

7.9. PCB Layout Considerations

Thanks to its fully integrated architecture PCB layout with the SX1230 can be straight forward. It is nonetheless a high performance RFIC therefore, to attain the best RF performance, certain design rules should be adhered to:

- ◆ When designing the a PCB layout for the SX1230 the use of at least two metallized layers is advised, one side forming the populated (component) layer, the second forming a continuous ground plane. Ideally this ground plane should be unbroken and be situated beneath the SX1230 circuit and RF signal path. Adopting this layout strategy minimizes the potential for spurious emission from, and coupling to, the SX1230.
- ◆ Decoupling components should be located as close as possible to the SX1230, ideally each with its own via connection direct to the ground plane.
- ◆ The crystal oscillator circuit is differential, so benefits from both symmetrical layout and proximity to the SX1230.
- ◆ The RF signal path should be kept as straight as possible, ideally duplicating the SX1230 reference design (SM1230).

For a more detailed treatment of the PCB layout for semtech devices please see application note AN1200.04 “RF design guidelines: PCB layout and circuit optimization”.

8. Reference Design

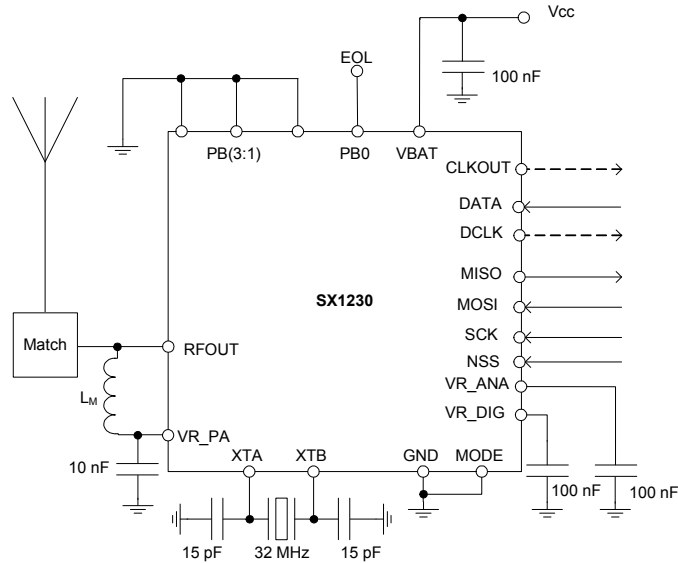

Figure 22. SX1230 Reference Design

The SX1230 reference design is shown above with connections for MCU mode operation. The values of all band independent components are shown, for the appropriate RF matching please see Section 7.6. The corresponding 2-layer PCB layout is shown in Figure 23. The example design size for the radio portion of the design (not including push button or stand alone mode functionality) is encompassed by the green box whose largest dimensions are 19 x 10 mm.

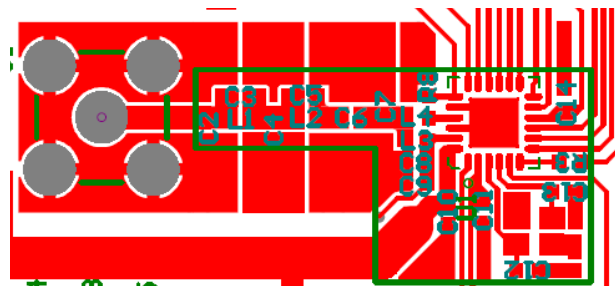

Figure 23. SX1230 Reference Design Example

9. Reference Design Performance

This section details the measured typical performance of the reference design described in the preceding section.

9.1. Power Output versus Consumption

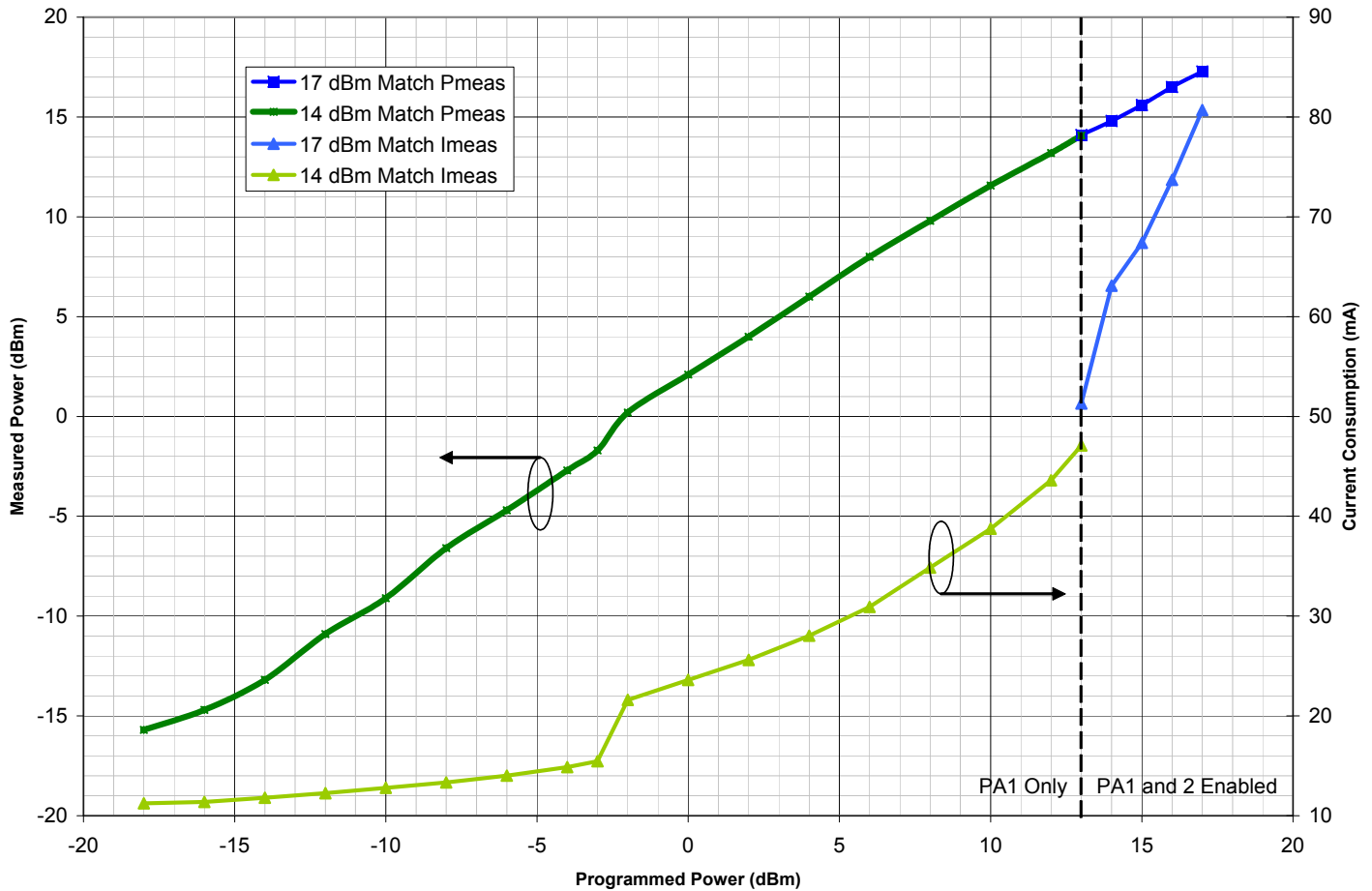

Figure 24. Typical Power Consumption of the Reference Design versus Measured and Programmed Power Output at 915 MHz

The measured current consumption of the SX1230 versus programmed and measured output power is shown in the preceding figure. The green curves correspond to measurements (made at 915 MHz) using the low power matching of Section 7.7. The measured consumption displays two distinct regimes: Above a programmed power of -3 dBm both high and low power amplifiers of PA1 are active. Below, however, only the low power amplifier within PA1 is enabled allowing enhanced efficiency for operation below this programmed power output.

The blue portion of the curve (13 to 17 dBm operation) uses the matching illustrated in Section 7.6. Note that not only must both power amplifiers be enabled to access these output powers, but also the OCP (current limiter) for the PA must be disabled or the limit adjusted to 100 mA accordingly.

9.2. Power Output Flatness versus Temperature and Supply Voltage

The SX1230 reference design power output flatness as a function of voltage and temperature is shown below.

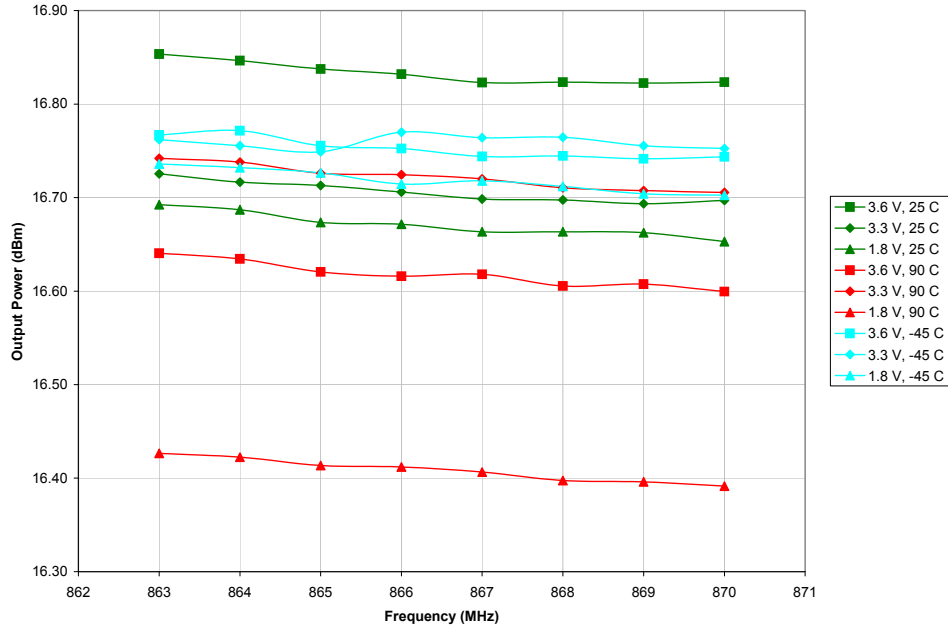

Figure 25. Typical 17 dBm Output Power Flatness versus Supply Voltage and Temperature, Measured in the 868 MHz ISM Band

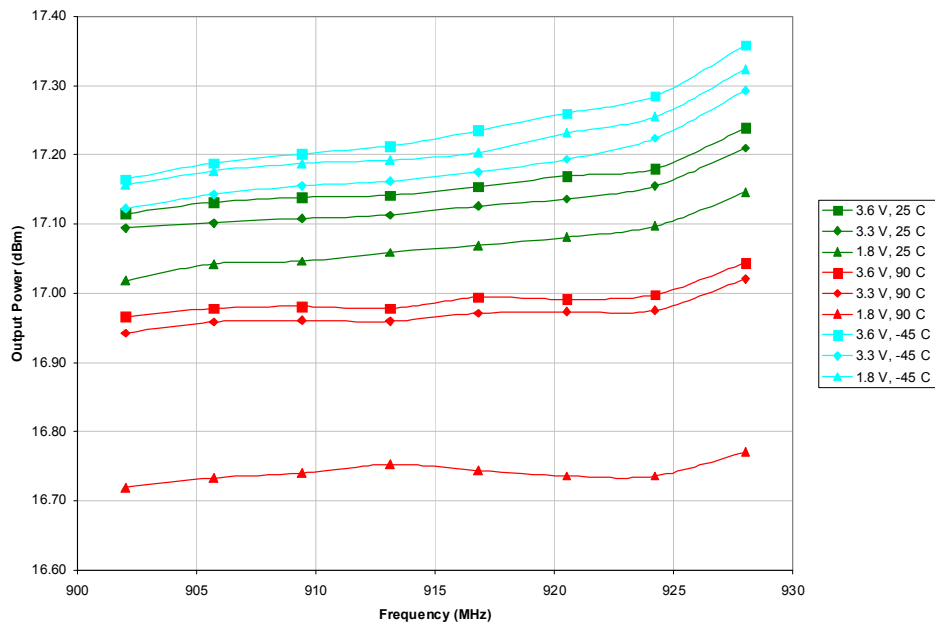

Figure 26. Typical 17 dBm Output Power Flatness versus Supply Voltage and Temperature, Measured in the 915 MHz ISM band

9.3. Phase Noise

The phase noise of the SX1230 is measured in the centre frequencies of the principal ISM bands below 1 GHz. The phase noise is a function of frequency and varies from -104 dBc/Hz at 50 kHz offset at 315 MHz band to -96dBc/Hz at 50 kHz offset at 915 MHz.

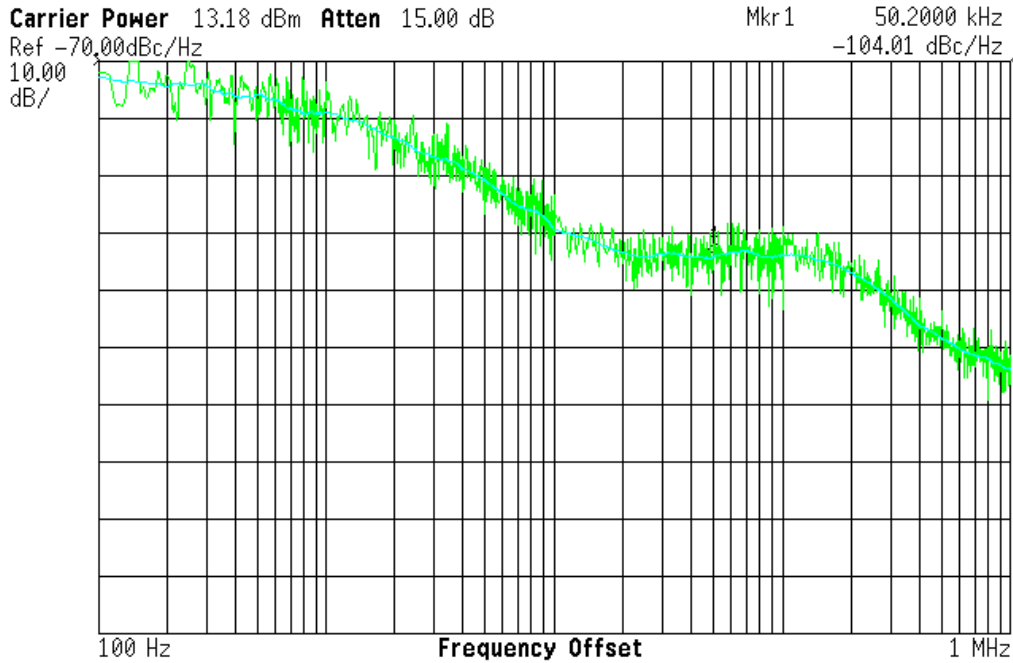

Figure 27. Typical SX1230 Phase Noise Measurement at 315 MHz (-104 dBc/Hz at 50 kHz).

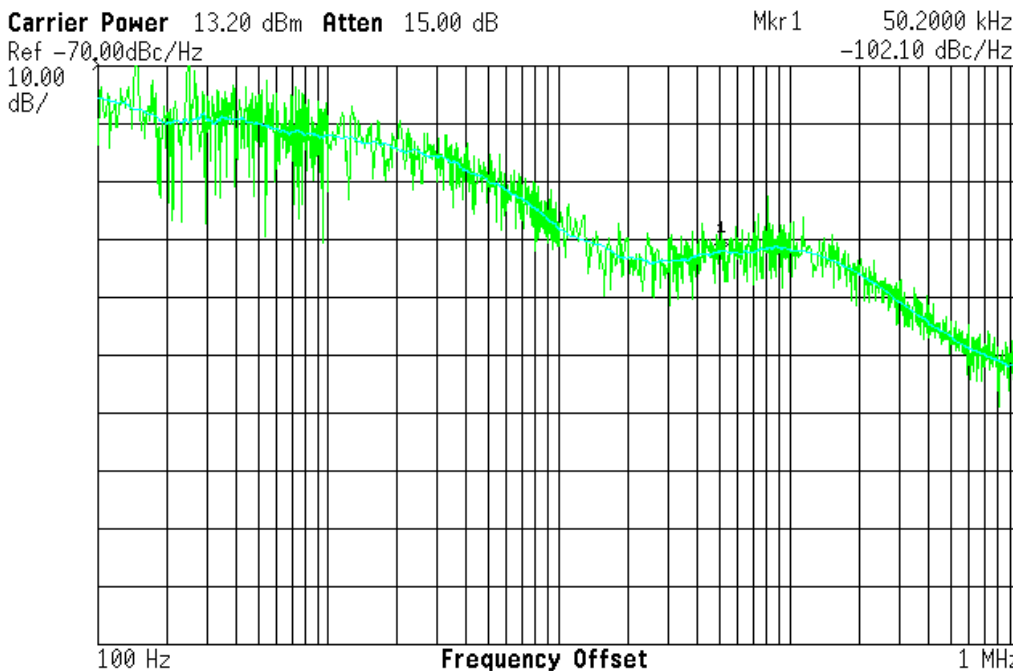

Figure 28. Typical SX1230 Phase Noise Measurement at 434 MHz (-102 dBc/Hz at 50 kHz).

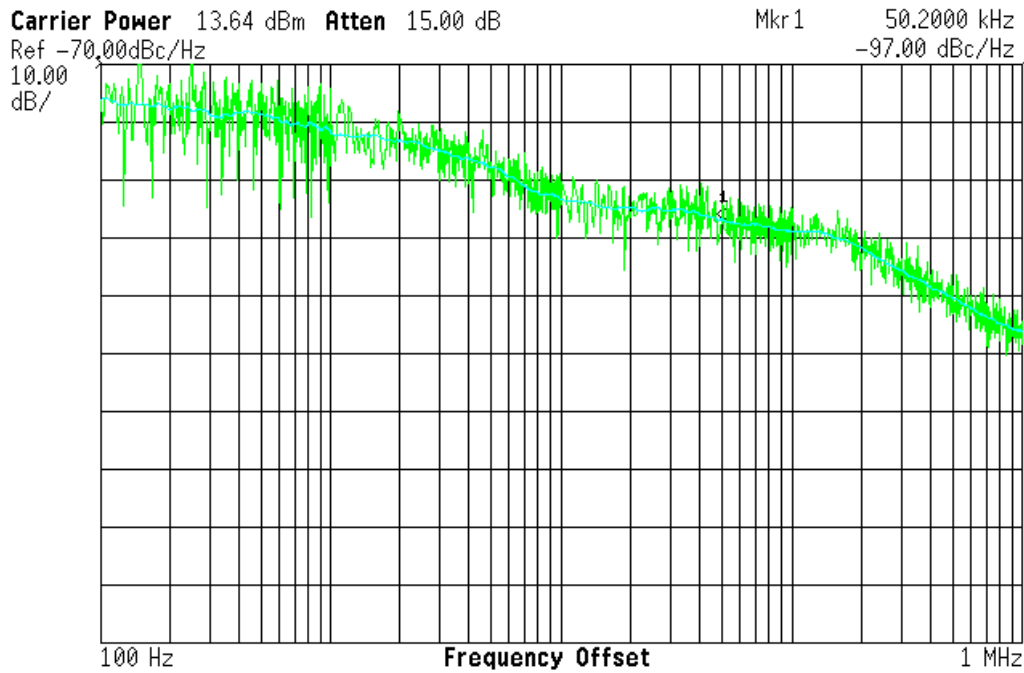

Figure 29. Typical SX1230 Phase Noise Measured at 868 MHz (-97 dBc/Hz at 50 kHz).

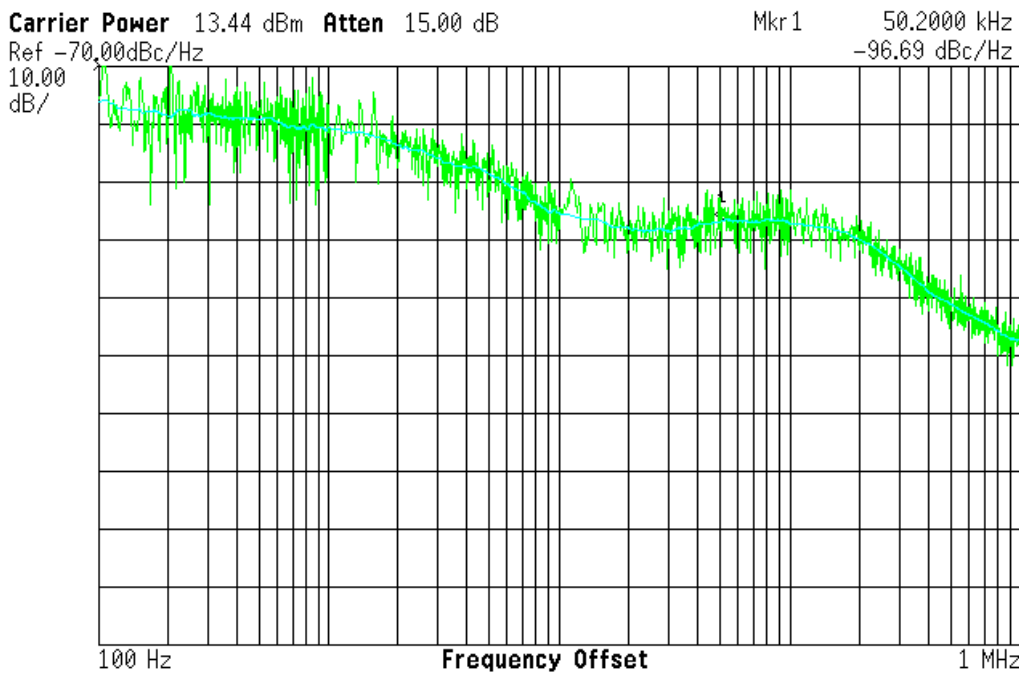

Figure 30. Typical SX1230 Phase Noise Measured at 915 MHz (-96 dBc/Hz at 50 kHz).

9.4. SX1230 Baseband Filtering

The following figure illustrates the effect of applying the baseband gaussian filtering to the modulating bitstream of the SX1230. This measurement was performed in the 868 MHz ISM band with the following settings: $P_{PGM} = 17$ dBm, $f_{RF} = 868$ MHz, $\Delta f = 50$ kHz and $R_b = 50$ kbps (implies $\beta=2$). Here we see the occupied bandwidth reduced from 500 kHz for the unfiltered bit stream to 330 kHz with a filtering coefficient (BT) of 1. By increasing the filtering strength further to BT=0.3, the channel bandwidth for operation in the 868 MHz ISM band is reduced to below 200 kHz.

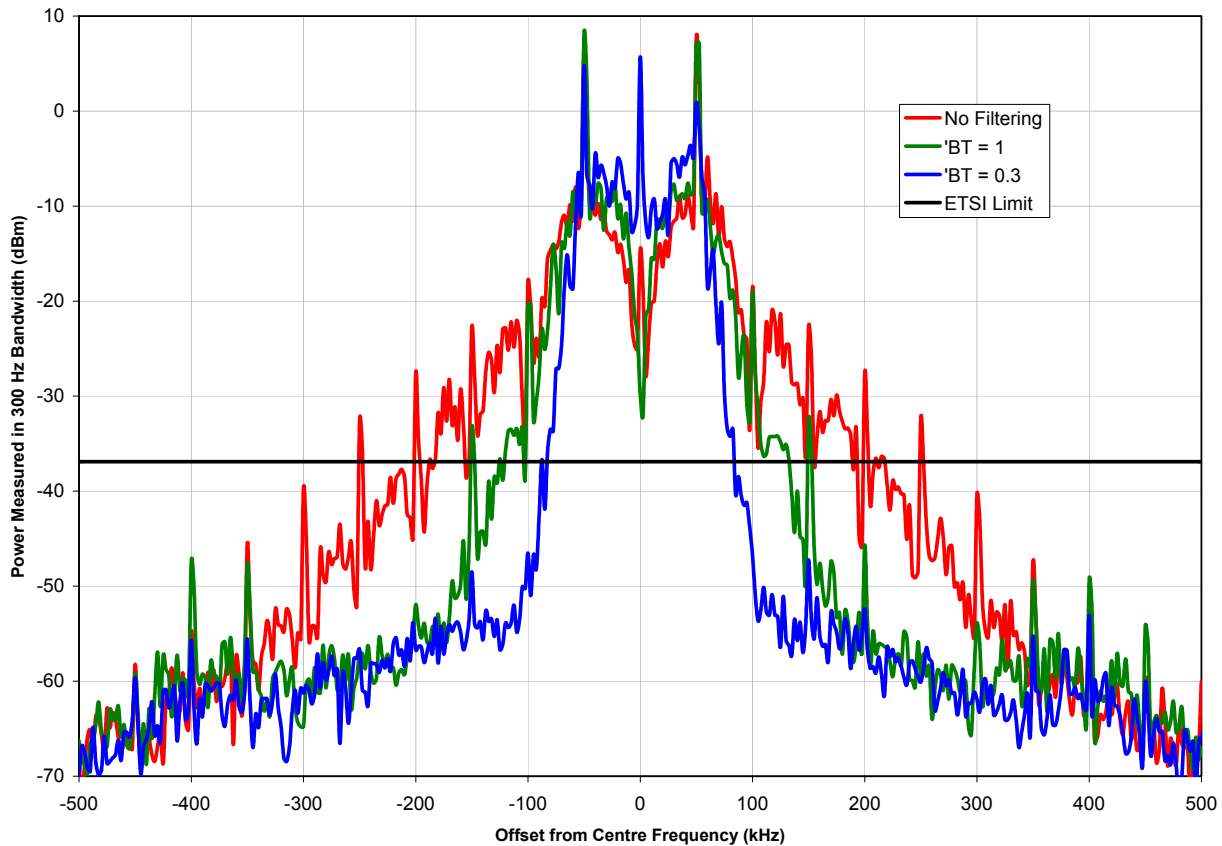

Figure 31. The Influence of Gaussian Filtering on the Modulation Bandwidth (Wideband)

9.5. Adjacent Channel Power

Modulation spectrum of the SX1230 measured in 100 Hz bandwidth is shown in the following three figures together with the integrated adjacent channel power for the modulation settings shown in the figure caption. Please note that all measurements were performed at 868 MHz, with an output power of 13 dBm. Please also note that the clock output was disabled.

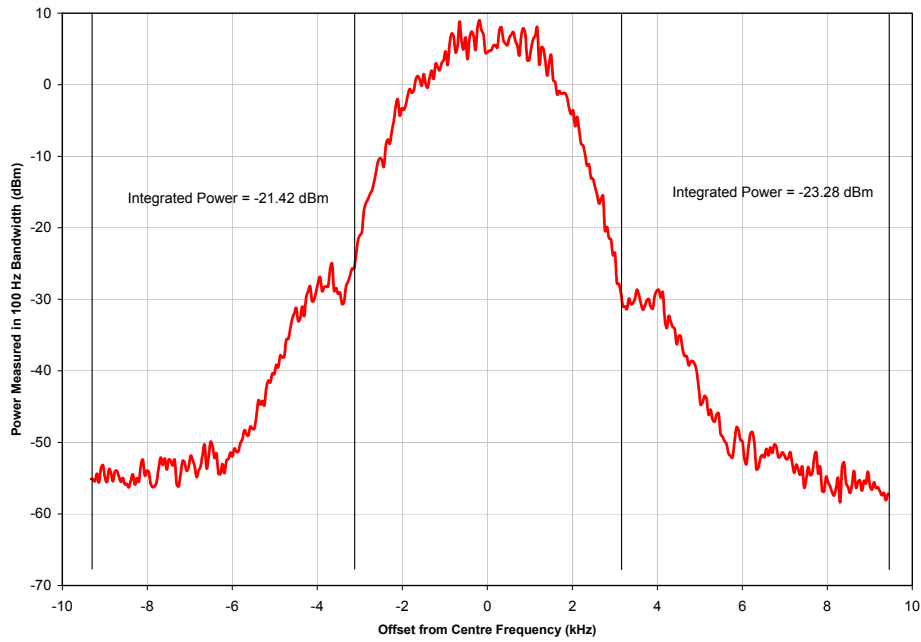

Figure 32. GMSK 6.25 kHz Channel Example. $\Delta f = 1.25$ kHz, $R_b = 4.8$ kbps (implies $\beta = 0.5$) and $BT = 0.3$.

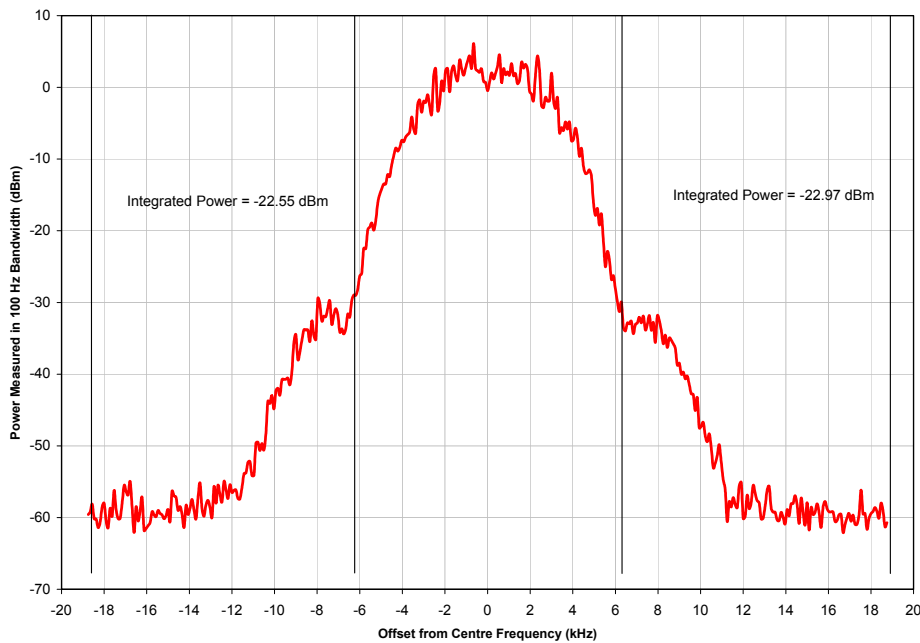

Figure 33. GMSK 12.5 kHz Channel Example. $\Delta f = 2.5$ kHz, $R_b = 9.6$ kbps (implies $\beta = 0.5$) and $BT = 0.3$.

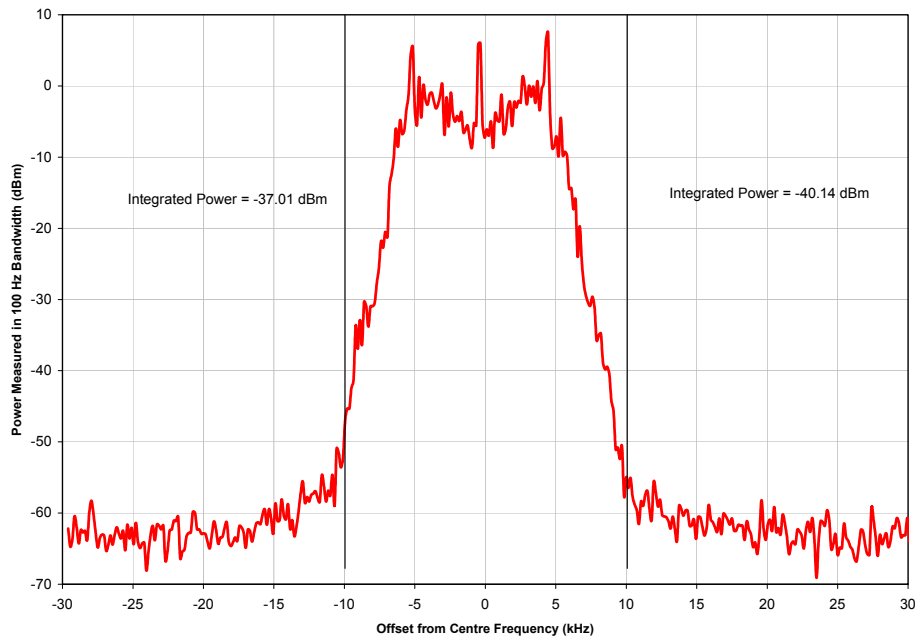
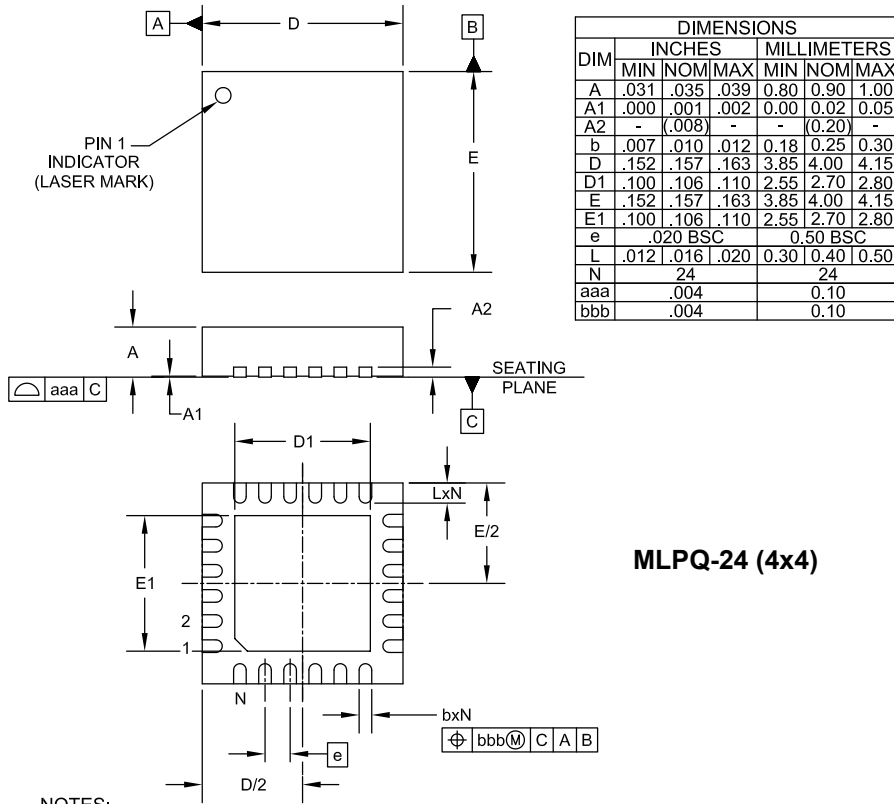

Figure 34. GFSK 20 kHz Channel Example. $\Delta f = 4.8$ kHz, $R_b = 4.8$ kbps (implies $\beta = 2$) and $BT = 0.3$.

10. Packaging Information



MLPQ-24 (4x4)

- NOTES:
1. CONTROLLING DIMENSIONS ARE IN MILLIMETERS (ANGLES IN DEGREES).
 2. COPLANARITY APPLIES TO THE EXPOSED PAD AS WELL AS THE TERMINALS.

11. Package Marking

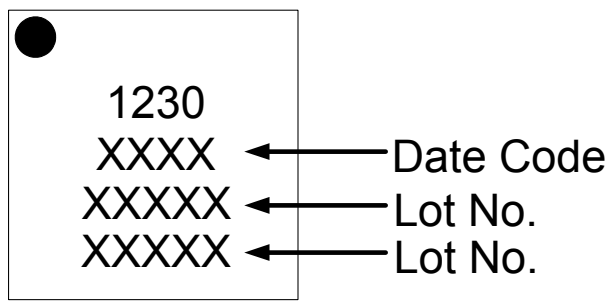

ST0002_01_US

12. Recommended PCB Land Pattern

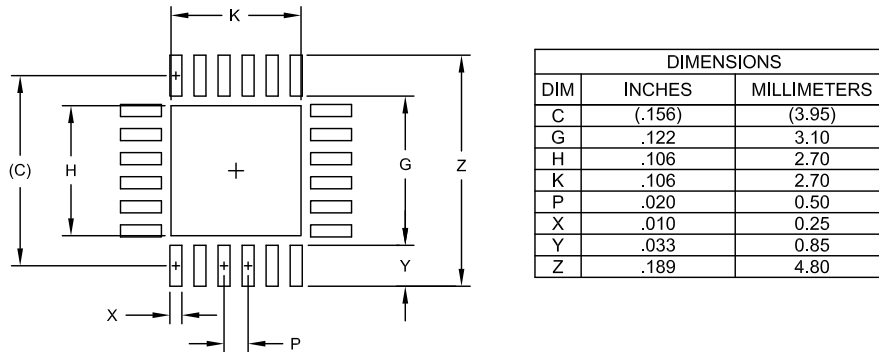
NOTES:

1. CONTROLLING DIMENSIONS ARE IN MILLIMETERS (ANGLES IN DEGREES).
2. THIS LAND PATTERN IS FOR REFERENCE PURPOSES ONLY. CONSULT YOUR MANUFACTURING GROUP TO ENSURE YOUR COMPANY'S MANUFACTURING GUIDELINES ARE MET.
3. THERMAL VIAS IN THE LAND PATTERN OF THE EXPOSED PAD SHALL BE CONNECTED TO A SYSTEM GROUND PLANE. FAILURE TO DO SO MAY COMPROMISE THE THERMAL AND/OR FUNCTIONAL PERFORMANCE OF THE DEVICE.

13. Soldering Profile

The soldering reflow profile for the SX1230 is described in the standard IPC/JEDEC J-STD-020C, max soldering temperature is 260° C.

Profile Feature	Sn-Pb Eutectic Assembly	Pb-Free Assembly
Average Ramp-Up Rate (Ts _{max} to Tp)	3 °C/second max.	3° C/second max.
Preheat		
– Temperature Min (Ts _{min})	100 °C	150 °C
– Temperature Max (Ts _{max})	150 °C	200 °C
– Time (ts _{min} to ts _{max})	60-120 seconds	60-180 seconds
Time maintained above:		
– Temperature (T _L)	183 °C	217 °C
– Time (t _L)	60-150 seconds	60-150 seconds
Peak/Classification Temperature (Tp)	See Table 4.1	See Table 4.2
Time within 5 °C of actual Peak Temperature (tp)	10-30 seconds	20-40 seconds
Ramp-Down Rate	6 °C/second max.	6 °C/second max.
Time 25 °C to Peak Temperature	6 minutes max.	8 minutes max.

Note 1: All temperatures refer to topside of the package, measured on the package body surface.

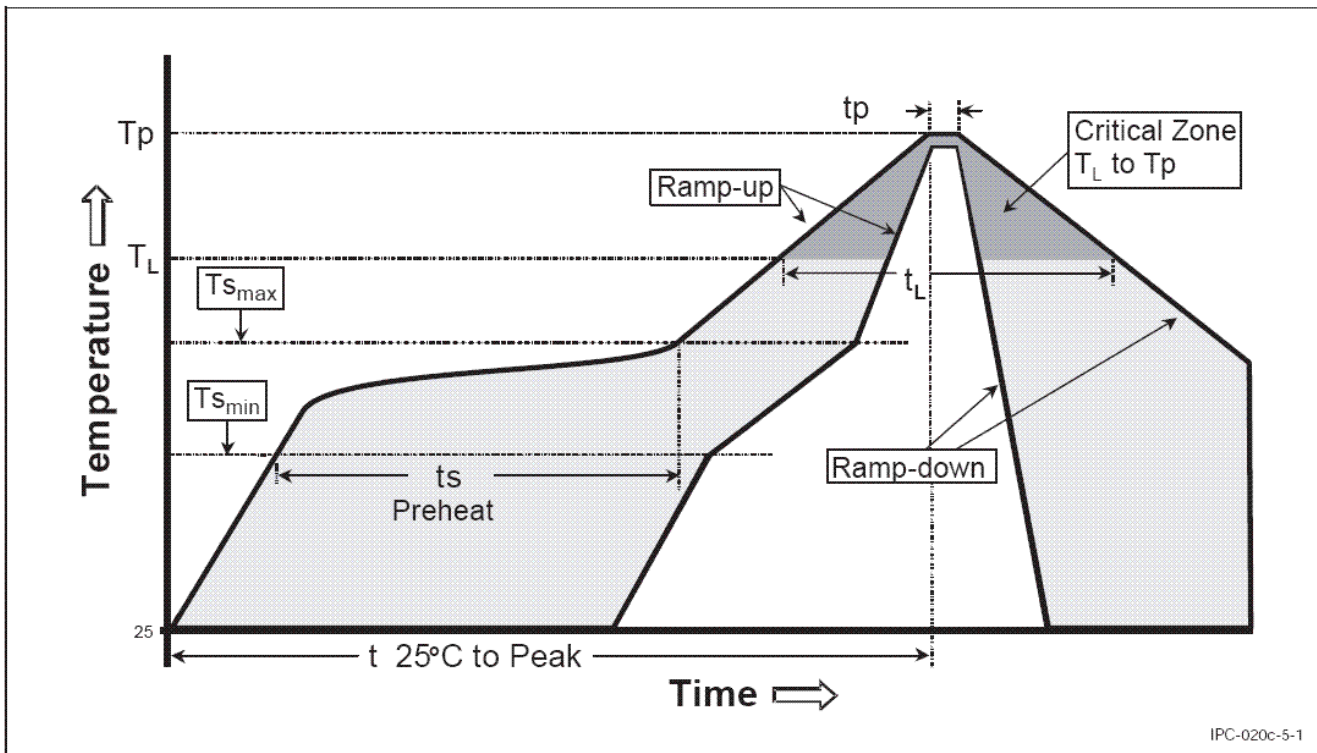

IPC-020c-5-1

© Semtech 2008

All rights reserved. Reproduction in whole or in part is prohibited without the prior written consent of the copyright owner. The information presented in this document does not form part of any quotation or contract, is believed to be accurate and reliable and may be changed without notice. No liability will be accepted by the publisher for any consequence of its use. Publication thereof does not convey nor imply any license under patent or other industrial or intellectual property rights. Semtech assumes no responsibility or liability whatsoever for any failure or unexpected operation resulting from misuse, neglect improper installation, repair or improper handling or unusual physical or electrical stress including, but not limited to, exposure to parameters beyond the specified maximum ratings or operation outside the specified range.

SEMTECH PRODUCTS ARE NOT DESIGNED, INTENDED, AUTHORIZED OR WARRANTED TO BE SUITABLE FOR USE IN LIFE-SUPPORT APPLICATIONS, DEVICES OR SYSTEMS OR OTHER CRITICAL APPLICATIONS. INCLUSION OF SEMTECH PRODUCTS IN SUCH APPLICATIONS IS UNDERSTOOD TO BE UNDERTAKEN SOLELY AT THE CUSTOMER'S OWN RISK. Should a customer purchase or use Semtech products for any such unauthorized application, the customer shall indemnify and hold Semtech and its officers, employees, subsidiaries, affiliates, and distributors harmless against all claims, costs damages and attorney fees which could arise.

Contact information

Semtech Corporation Advanced Communications & Sensing Products

E-mail: sales@semtech.com acsupport@semtech.com Internet: <http://www.semtech.com>

USA

200 Flynn Road, Camarillo, CA 93012-8790.
Tel: +1 805 498 2111 Fax: +1 805 498 3804

FAR EAST

12F, No. 89 Sec. 5, Nanking E. Road, Taipei, 105, TWN, R.O.C.
Tel: +886 2 2748 3380 Fax: +886 2 2748 3390

EUROPE

Semtech Ltd., Units 2 & 3, Park Court, Premier Way, Abbey Park Industrial Estate, Romsey, Hampshire, SO51 9DN.
Tel: +44 (0)1794 527 600 Fax: +44 (0)1794 527 601