

SX-4289

LH3 Steering Sensor with Torque and Position Output

The LH3 torque and position sensor is ideally suited for demanding Electric Power Steering systems.

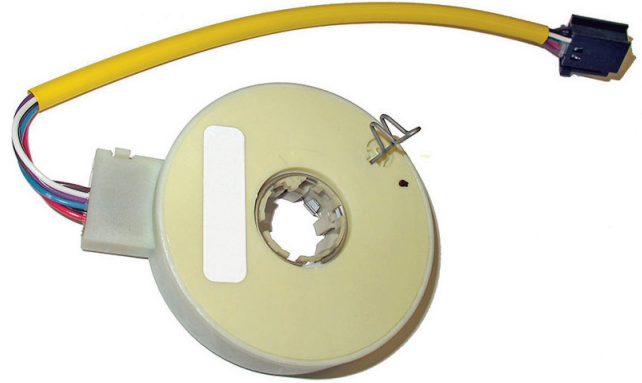

ELECTRICAL¹

Torque Signal Linearity	±3%
Torque Hysteresis	0.5%
Torque Signal Microgradient	±30% of theoretical slope over 0.4° interval
Torque Signal Sensing Angle	±8°
Position Signal Linearity	±1.5%
Position Signal Microgradient	±30% of theoretical slope over 2° interval
Total Resistance	518 Ω ±30%

MECHANICAL

Torque Mechanical Travel	±11.4°
Turning Torque (rotor to rotor)	0.03 NM Max.
Turning Torque (position rotor to housing)	0.06 NM Max.
Position Mechanical Travel	Continuous
Weight	95 grams maximum

ENVIRONMENTAL

Operating Temperature Range	-40°C to +85°C
Shock	14 ms half-sine at 300 m/s ²
Vibration	10 to 55 Hz with 1 mm P-P constant displacement, 120 hours each of 3 planes
Torque Rotational Life	1 million cycles
Position Rotational Life	1 million cycles
Storage Temperature Range	-40°C to +105°C

¹ Specifications subject to change without notice.



SX-4289

OUTPUT CHARTS

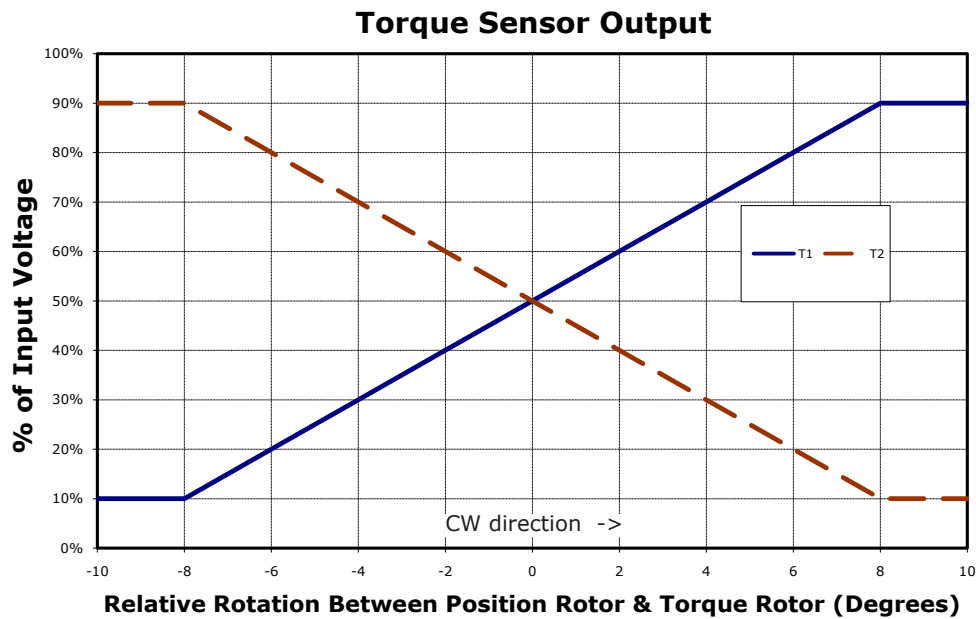
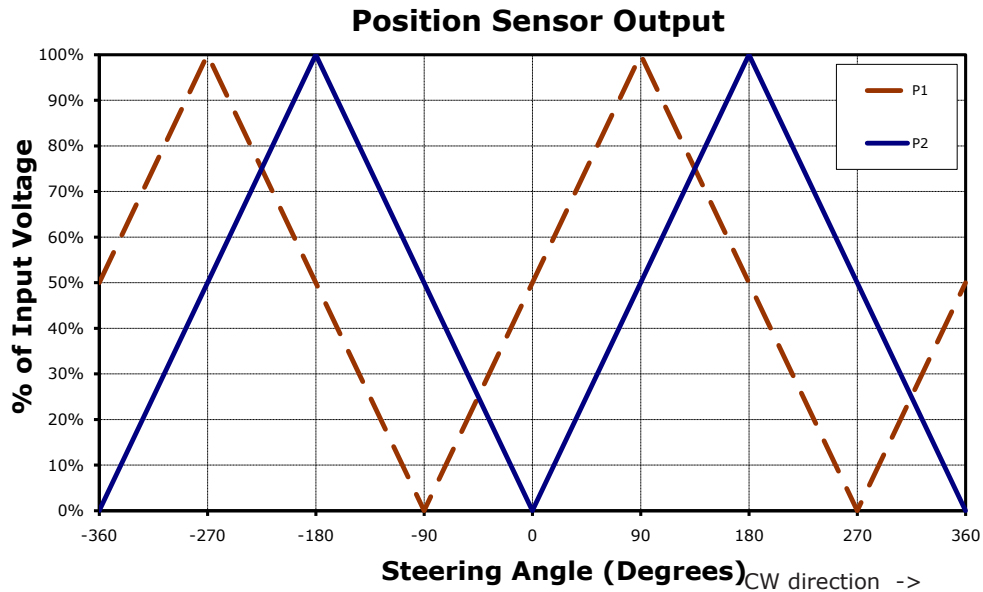

SX-4289

OUTLINE DRAWING

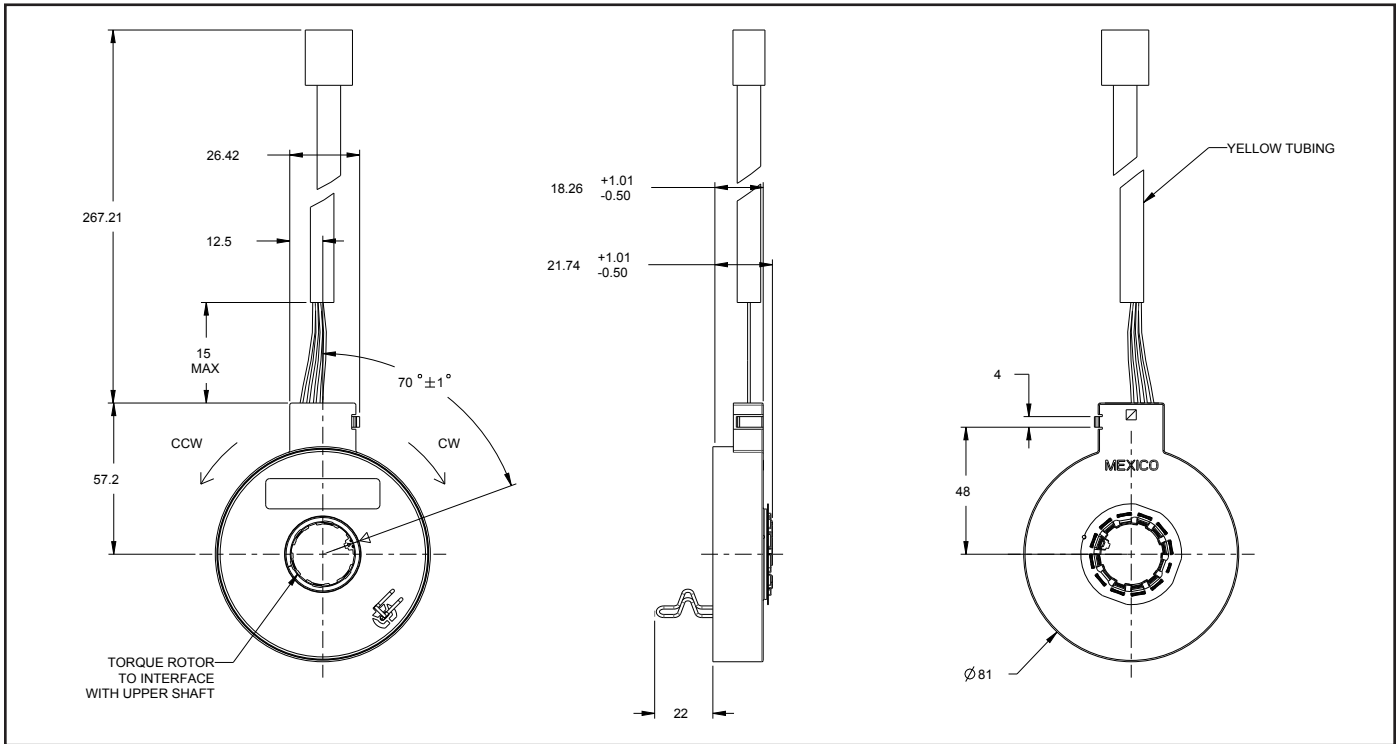

Tolerances ± 0.25 mm unless otherwise specified. See drawing # 122-4289-80 for details.

PINOUTS

PIN OUTS-6 PIN CONNECTOR		
PACKARD 15336723		
1	2	3
4	5	6

PIN No.	SIGNAL	WIRE COLOR
1	T1	BLUE
2	Vcc	RED
3	T2	PURPLE
4	P1	BROWN
5	GND	BLACK
6	P2	WHITE

BARCODE LABEL

Code 128 symbology

4289 A Y DDD T SSSS

Model #

Last digit
of year

Tester #

BI revision
letter

Day of
year

Sequential
serial #

BI Technologies Corporation

4200 Bonita Place, Fullerton, CA 92835 USA

Phone: 714 447 2345 Website: www.bitechnologies.com

April 26 2016

SX-4289 page 3 of 4

SX-4289

RECOMMENDED INTERFACE

