

# Thyristors

## T30



### Technical Data

Typical applications : D.C. Motor control, Controlled rectifiers, A.C. Controllers

Type No.	$V_{RRM}$ (Volts)	$V_{RSM}$ (Volts)
T30/04	400	500
T30/06	600	700
T30/08	800	900
T30/10	1000	1100
T30/12	1200	1300
T30/14	1400	1500
T30/16	1600	1700

### Features

- Hermetic glass to metal seal
- Voltage grade upto 1600V
- Weight 15 gm ( Approx )

Symbol	Conditions	Values
$I_{T(AV)}$	Half wave resistive load; $T_{case} = 85\text{ }^{\circ}\text{C}$	30 A
$I_{TSM}$	$T_{vj} = 125\text{ }^{\circ}\text{C}$ ; 10 ms half sine, $V_R = 50\% V_{RRM}$	500 A
$I^2t$	$T_{vj} = 125\text{ }^{\circ}\text{C}$ ; 10 ms half sine	1250 A <sup>2</sup> s
	$T_{vj} = 125\text{ }^{\circ}\text{C}$ ; 3 ms half sine	1000 A <sup>2</sup> s
$I_{GT}$	$T_{vj} = 25\text{ }^{\circ}\text{C}$ ; $V_{DRM} = 5V$	100 mA
$V_{GT}$	$T_{vj} = 25\text{ }^{\circ}\text{C}$ ; $V_{DRM} = 5V$	3.0V
$dv/dt$	$T_{vj} = 125\text{ }^{\circ}\text{C}$ ; Voltage = 67 % $V_{DRM}$	*200 V/ $\mu$ s
$[di/dt]_{CR}$	Repetitive 50 Hz	150 A/ $\mu$ s
$V_T$	$T_{vj} = 25\text{ }^{\circ}\text{C}$ ; $I_T = 100A$	1.80V max
$I_{RRM}/I_{DRM}$	$T_{vj} = 125\text{ }^{\circ}\text{C}$	5.0 mA
$I_L$	Max value.	300 mA
$R_{th(j-h)}$	dc	0.6 $^{\circ}\text{C}/\text{W}$
	Half wave	0.7 $^{\circ}\text{C}/\text{W}$
	3-Phase	0.8 $^{\circ}\text{C}/\text{W}$
$T_{vj}$		+ 125 $^{\circ}\text{C}$
$T_{stg}$		-40.....+ 125 $^{\circ}\text{C}$
Mounting torque		2.5 Nm
Case outline		N

\* Higher dv/dt selection available on request



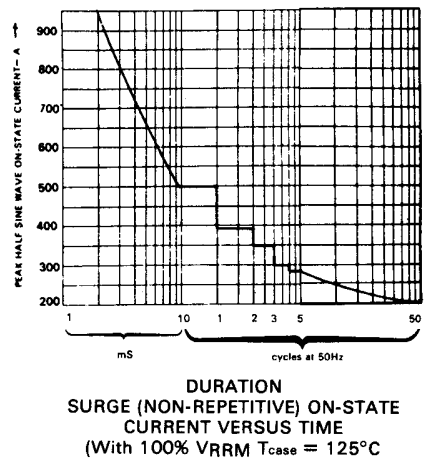
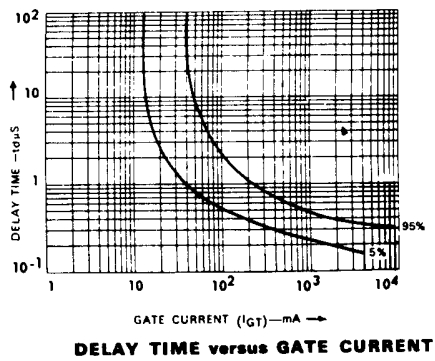
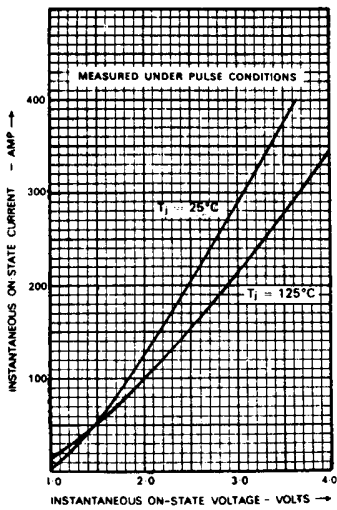
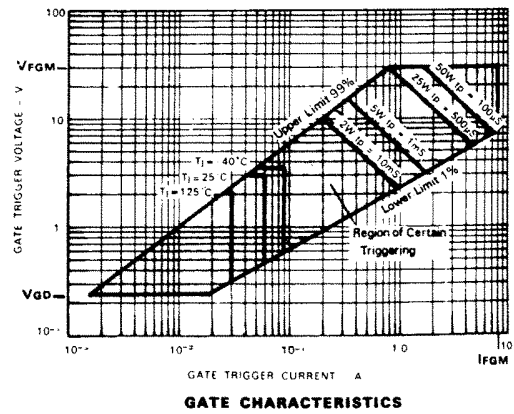
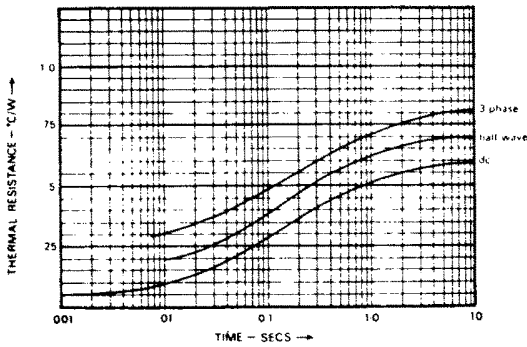
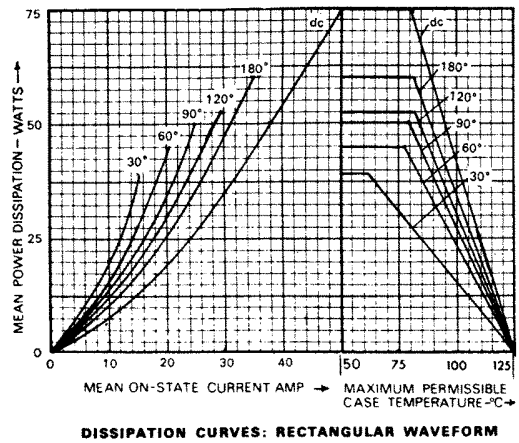
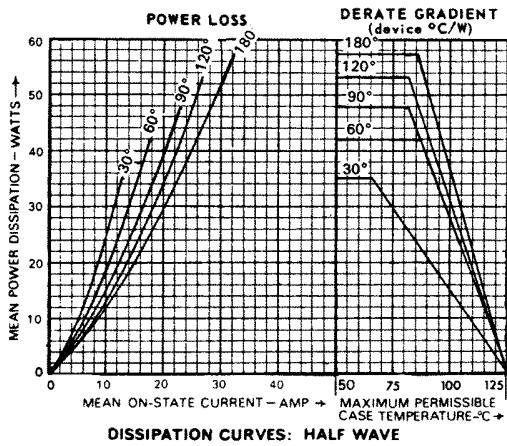

PACAKAGE DEATILS

DO NOT SCALE

All Dimensions in mm

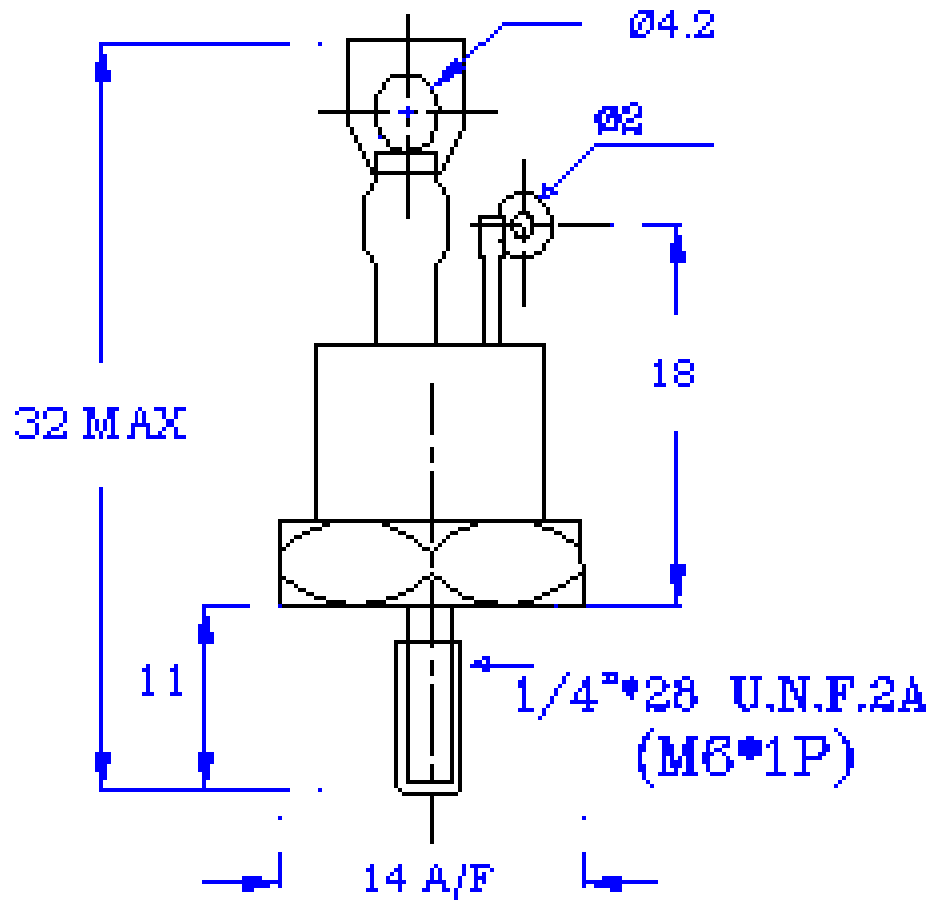

Alt : Also available with pigtail

Mounting Torque: 2.5Nm **N**