

**SURFACE MOUNT  
THYRISTOR SURGE PROTECTIVE DEVICE**

**Bi-Directional**  
VDRM - **58 to 320** Volts  
IPP - **50** Amperes

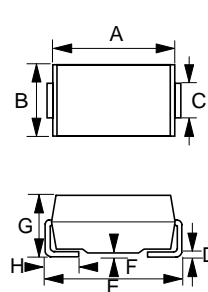
**FEATURES**

- Oxide Glass Passivated Junction
- Bidirectional protection in a single device
- Surge capabilities up to 50A @10/1000us or 250A @8/20us
- High off state Impedance and low on state voltage
- Plastic material has UL flammability classification 94V-0

**MECHANICAL DATA**

- Case : Molded plastic
- Polarity : Denotes none cathode band
- Weight : 0.093 grams

**SMA**



SMA		
DIM.	MIN.	MAX.
A	4.06	4.57
B	2.29	2.92
C	1.27	1.63
D	0.15	0.31
E	4.83	5.59
F	0.05	0.20
G	2.01	2.62
H	0.76	1.52

All Dimensions in millimeter

**MAXIMUM RATINGS**

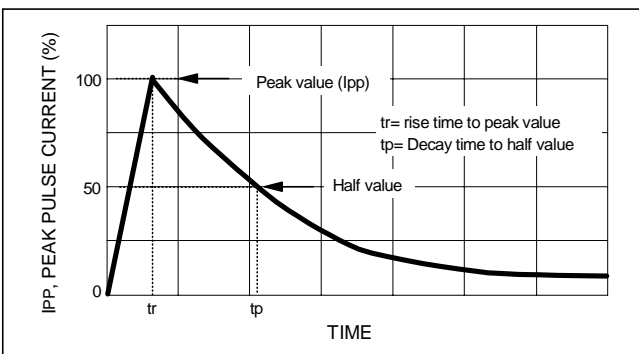
CHARACTERISTICS	SYMBOL	VALUE	UNIT
Non-repetitive peak impulse current @ 10/1000us	IPP	50	A
Non-repetitive peak On-state current @ 8.3ms (one half cycle)	ITSM	25	A
Junction temperature range	TJ	-40 to +150	°C
storage temperature range	TSTG	-55 to +150	°C

**THERMAL RESISTANCE**

CHARACTERISTICS	SYMBOL	VALUE	UNIT
Junction to leads	Rth(J-L)	20	°C/W
Junction to ambient on print circuit (on recommended pad layout)	Rth(J-A)	100	°C/W
Typical positive temperature coefficient for brekdown voltage	$\Delta V_{BR}/\Delta T_J$	0.1	%/°C

**MAXIMUM RATED SURGE WAVEFORM**

WAVEFORM	STANDARD	IPP (A)
2/10 us	GR-1089-CORE	300
8/20 us	IEC 61000-4-5	250
10/160 us	FCC Part 68	150
10/700 us	ITU-T K20/21	100
10/560 us	FCC Part 68	75
10/1000 us	GR-1089-CORE	50

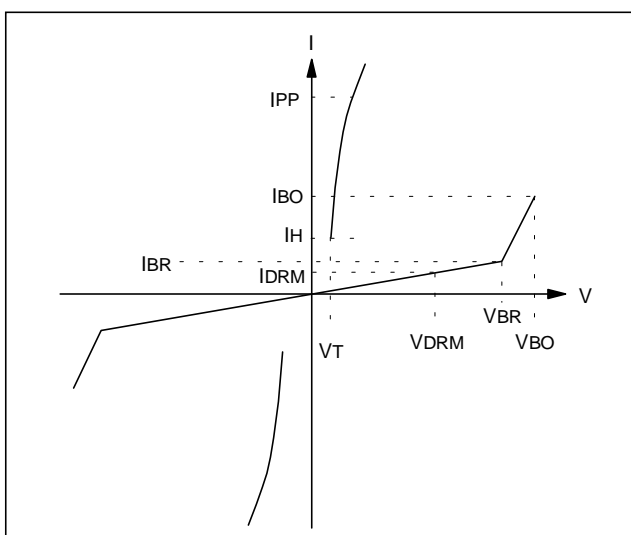


**ELECTRICAL CHARACTERISTICS @ TA= 25°C unless otherwise specified  
TA0640M thru TA3500M**



PARAMETER	RATED REPETITIVE OFF-STATE VOLTAGE	OFF-STATE LEAKAGE CURRENT @ VDRM	BREAKOVER VOLTAGE	ON-STATE VOLTAGE @ IT=1.0A	BREAKOVER CURRENT		HOLDING CURRENT		OFF-STATE CAPACITANCE
					IBO-	IBO+	IH-	IH+	
SYMBOL	VDRM	IDRM	VBO	VT	IBO-	IBO+	IH-	IH+	Co
UNITS	Volts	uA	Volts	Volts	mA	mA	mA	mA	pF
LIMIT	Max	Max	Max	Max	Min	Max	Min	Max	Typ
TA0640M	58	5	77	3.5	50	800	150	800	140
TA0720M	65	5	88	3.5	50	800	150	800	140
TA0900M	75	5	98	3.5	50	800	150	800	140
TA1100M	90	5	130	3.5	50	800	150	800	90
TA1300M	120	5	160	3.5	50	800	150	800	90
TA1500M	140	5	180	3.5	50	800	150	800	90
TA1800M	160	5	220	3.5	50	800	150	800	90
TA2300M	190	5	265	3.5	50	800	150	800	60
TA2600M	220	5	300	3.5	50	800	150	800	60
TA3100M	275	5	350	3.5	50	800	150	800	60
TA3500M	320	5	400	3.5	50	800	150	800	60

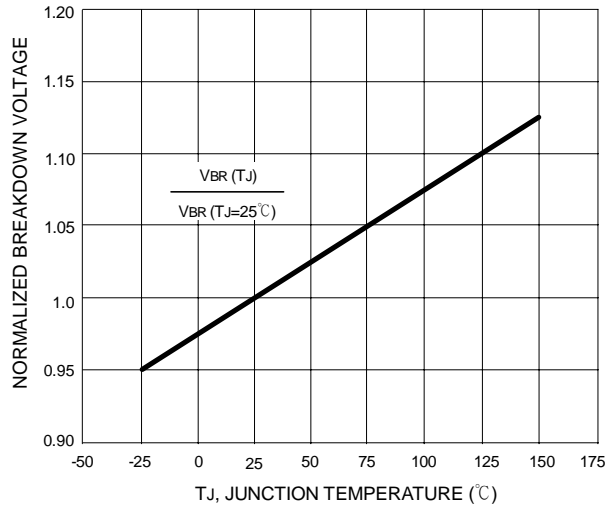
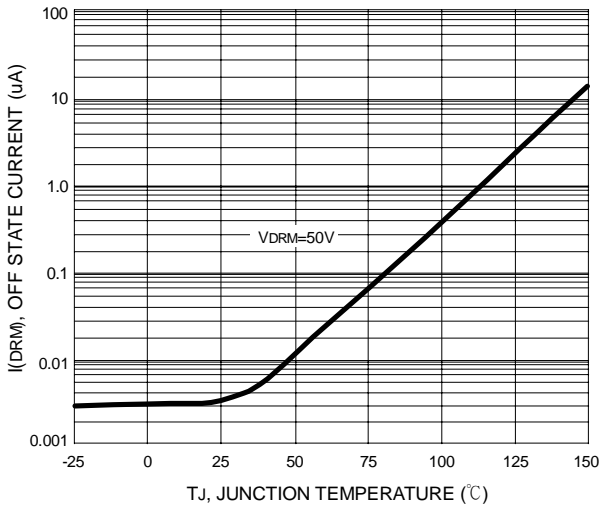
SYMBOL	PARAMETER
VDRM	Stand-off Voltage
IDRM	Leakage current at stand-off voltage
VBR	Breakdown voltage
IBR	Breakdown current
VBO	Breakover voltage
IBO	Breakover current
IH	Holding current <span style="float:right">Note: 1</span>
VT	On state voltage
IPP	Peak pulse current
CO	Off state capacitance <span style="float:right">Note: 2</span>



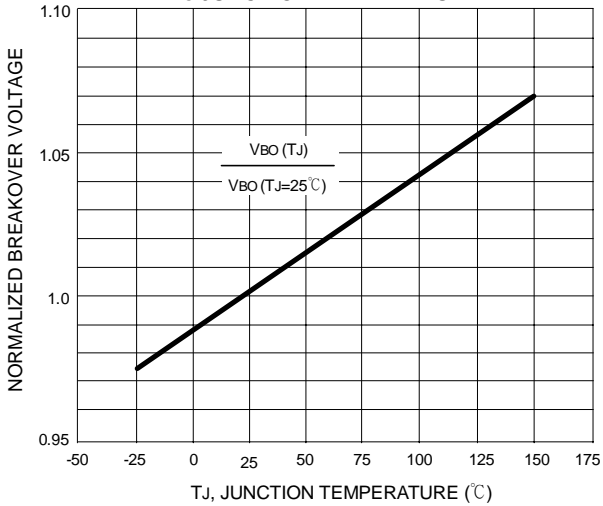
REV. 0, 03-Dec-2001, KSWA03

NOTES: 1.  $I_H > (V_L/R_L)$  If this criterion is not obeyed, the TSPD Triggers but does not return correctly to high-resistance state. The Surge recovery time does not exceed 30ms.  
2. Off-state capacitance measured at  $f=1.0\text{MHz}$ ;  $1.0V_{RMS}$  signal;  $V_R=2V_{DC}$  bias.

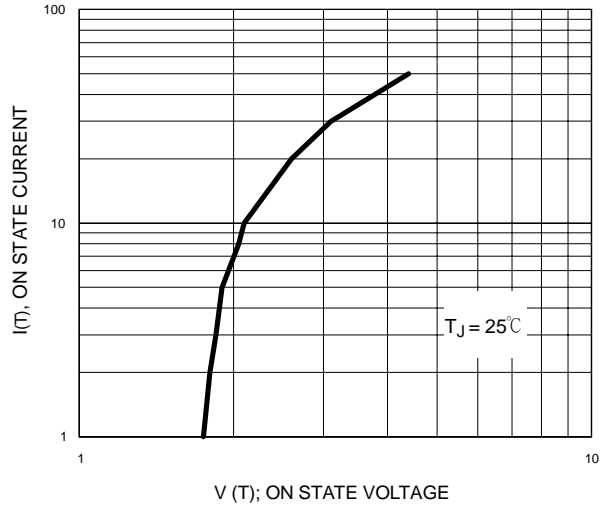
**FIG. 1 - OFF STATE CURRENT vs JUNCTION TEMPERATURE**      **FIG. 2 - RELATIVE VARIATION OF BREAKDOWN VOLTAGE vs JUNCTION TEMPERATURE**



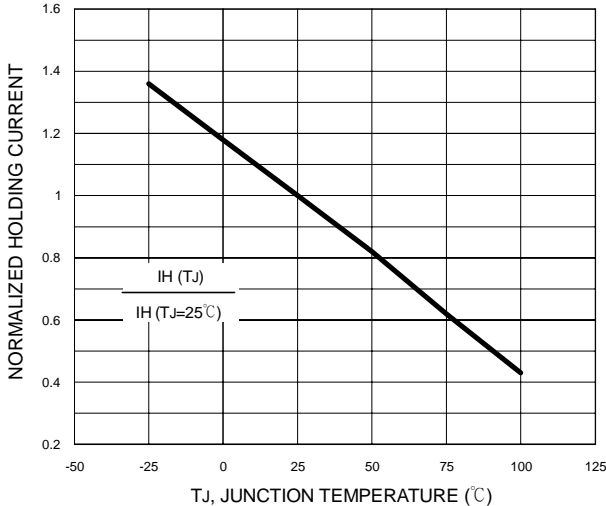
**FIG. 3 - RELATIVE VARIATION OF BREAKOVER VOLTAGE vs JUNCTION TEMPERATURE**



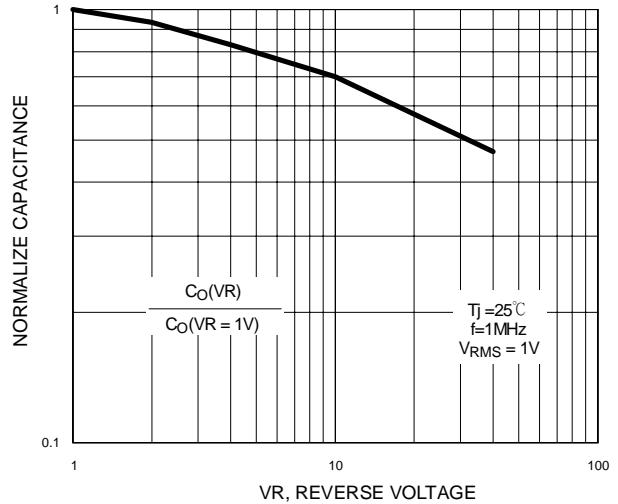
**FIG. 4 - ON STATE CURRENT vs ON STATE VOLTAGE**

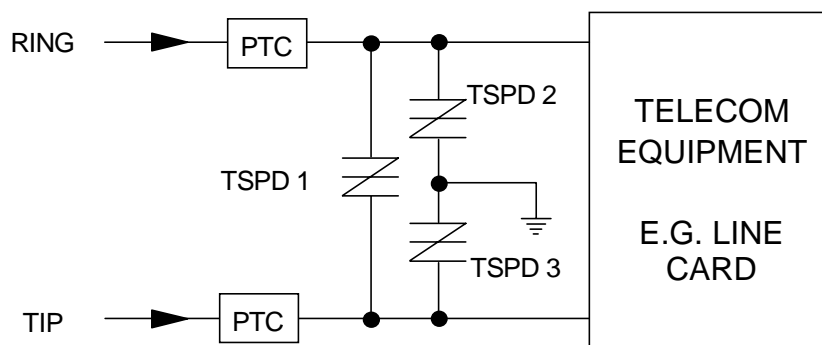
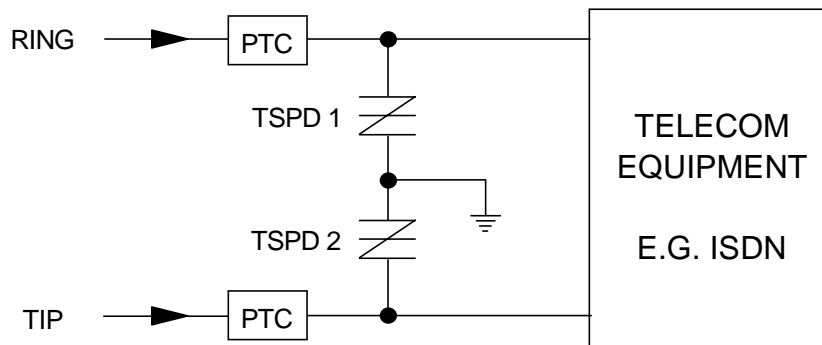
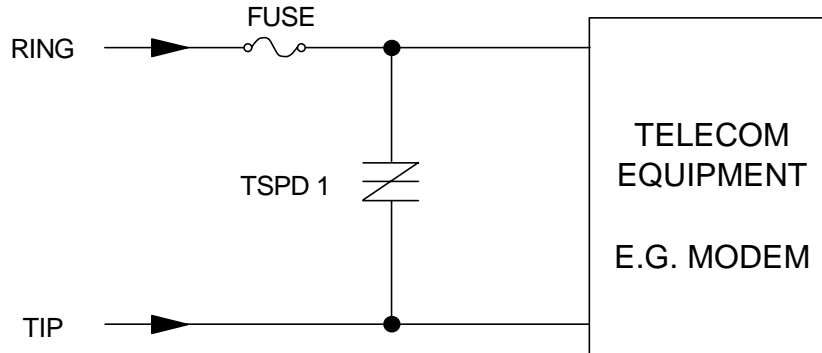


**FIG. 5 - RELATIVE VARIATION OF HOLDING CURRENT vs JUNCTION TEMPERATURE**



**FIG. 6 - RELATIVE VARIATION OF JUNCTION CAPACITANCE vs REVERSE VOLTAGE BIAS**





The PTC (Positive Temperature Coefficient) is an overcurrent protection device