



TOSHIBA Bi-CMOS Integrated Circuit Silicon Monolithic

TB62713N/F

Intelligent 5 X 7 LED Dot Matrix Display Controller Featuring Toshiba's exclusive *Constant Current* technology.

The TB62713F is an intelligent, *Constant Current*, 5 X 7 LED dot matrix display decoder and driver. The stand alone device includes all of the decode, multiplex and driver circuitry necessary to control a 5 X 7 LED matrix. An internal character set includes 128 characters to simplify programming and refresh functions are handled automatically. All display data, including a 16 step brightness control is input via the serial data port.

Features

- *Constant Current* row drivers for consistent display brightness.
- Single device saves labor and board space.
- 128 character internal character set simplifies design efforts.
- Automatically handles multiplex and display refresh tasks.
- 16 step programmable brightness control.
- Available in thru hole and surface mount packages.
- Data out cascade connection port.

Performance Characteristics

$V_{DD} = 4.5V \sim 5.5V$

Column source output: $-17V / 350mA$

Row select output: $17V / 0-50mA$

Max transition frequency: 15MHz

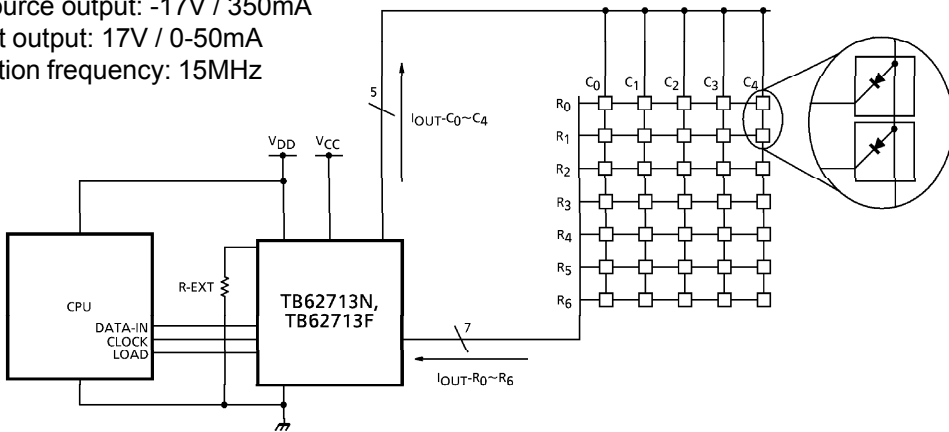

TB62713N

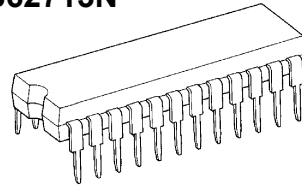

SDIP24-P-300-1.78 Weight: 1.62g (Typ.)

TB62713F

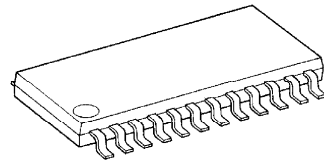

SSOP24-P-300-1.00 Weight: 0.32g (Typ.)

TOSHIBA Bi-CMOS Integrated Circuit Silicon Monolithic



TB62713N/F

Block Diagram

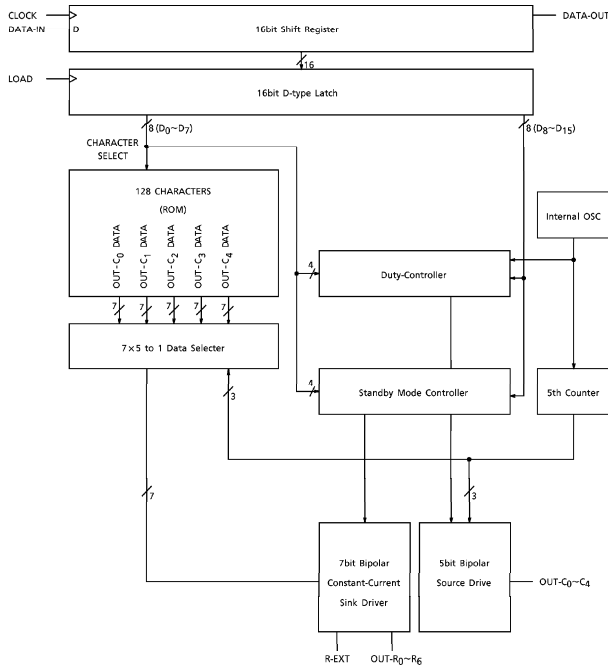

Maximum Ratings:

CHARACTERISTICS	SYMBOL	RATING	UNIT	
Supply Voltage	VDD	7.0	volts	
LED Supply Voltage	VCC	17.0	volts	
Source Output Current Columns 0~4	ICO	-420.0	mA	
Row Drive Current Rows 0~6	IRO	60.0	mA	
Output Current	IOH/IOL	+/-5.0	mA	
Input Voltage	VIN	-0.3 ~ VDD ~+0.3	volts	
Clock Frequency	FCLK	15.0	MHz	
Total Output Current	IVDD	420.0	mA	
Power Dissipation	Pd	TB62713N	1.78	W
		TB62713F	0.62	
Operation Temperature	Topr	-40 ~ +85	°C	
Storage Temperature	Tstg	-55 ~+150	°C	



120 Broadway • Menands, New York 12204
Toll Free: (800) 98-4LEDS • Fax: (518) 432-7454

For up-to-date product info visit our web site at www.marktechopto.com

All specifications subject to change.



TOSHIBA Bi-CMOS Integrated Circuit Silicon Monolithic

TB62713N/F

Recommended Operating Condition:

CHARACTERISTICS	SYMBOL	TEST CIRCUIT	CONDITION	MIN.	TYP.	MAX.	UNIT
-----------------	--------	--------------	-----------	------	------	------	------

Output Stage

Supply Current	ICC1	1	Set normal operation mode R _{ext} =590Ω, Out R0~R6, all on VCC = 5V, Ta=25°C	—	370	—	mA
	ICC2	1	Set normal operation mode R _{ext} =590Ω, Out R0~R6, all on VCC = 12V, Ta=25°C	—	390	—	mA
Column C0~C4 Scanning Frequency	fOSC	2	Normal operation mode VDD=4.5 - 5.5V	300	600	1200	Hz
Col. C0~C4 Leakage Current	I _{LEAK1}	4	All off mode, VCC=17V	—	—	-20	μA
Row R0~R6 Leakage Current	I _{LEAK2}	4	All off mode, VCE=17V	—	—	20	mA
Row R0~R6 Sink Current	I _{RO}	3	Normal operation, VCE=.7V, R _{ext} =590Ω,	36.5	43	49.4	μA
Col. C0~C4 Leakage Voltage	V _{OUT}	5	Normal operation mode I _{OUT-cn} = -350mA	3.0	—	—	V

Logic

Supply Current	IDD1	6	Standby Mode, Ta=25°C	—	—	200	μA
	IDD2	6	Blank Mode, Ta=25°C	—	—	12.5	mA
Operating Supply Current	IDD3	6	Normal operating mode fCLK=10MHz, Ta=25°C Data-in:Rows R0~R6 on	—	—	20.5	mA
High Level Input Current	I _{IH}	—	Data-in, Load&Clock VIN=5V	—	—	1	μA
Low Level Output Current	I _{IL}	—	Data-in, Load&Clock VIN=0V	—	—	-1	μA
High Level Output Voltage	VOH1	6	Data out, IOH=-1mA	4.6	—	—	V
	VOH2	6	Data-out, IOH=-1μA	—	VDD	—	V
Low Level Output Voltage	VOL1	6	Data out, IOL=-1mA	—	—	0.4	V
	VOL2	6	Data-out, IOL=-1μA	—	0.1	—	V
Clock Frequency	FCLK	6	Cascade connected	10	—	—	MHz

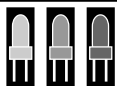

marktech
optoelectronics

120 Broadway • Menands, New York 12204

Toll Free: (800) 98-4LEDS • Fax: (518) 432-7454

TOSHIBA Bi-CMOS Integrated Circuit Silicon Monolithic



TB62713N/F

Switching Characteristics:

CHARACTERISTICS	SYMBOL	CONDITION	MIN.	TYP.	MAX.	UNIT
Data Hold Time (D-IN Clock)	tDHO		—	10	—	ns
Data Set-up Time (D-IN Clock)	tDST		—	20	—	ns
Serial Output Delay	tPDSO	CL=10pf	—	25	—	ns
High Level Pulse Width Of Clock	tCLKH		—	30	—	ns
Low Level Pulse Width Of Clock	tCLKL		—	30	—	ns
Pulse Width Of Load	tw LD		—	100	—	ns
Setup Time (Clock-Load)	tCLK-LD		—	50	—	ns
Setup Time (Load-Clock)	tLD-CLK		—	50	—	ns
Col. C0~C6 Propagation Delay (Load-Outn)	tPDCO	CL=10pf	—	—	5.0	μs
Col. C0~C6 Rise Time (OUTn)	tr CO	CL=10pf	0.2	1.0	—	μs
Col. C0~C6 Fall Time (OUTn)	tf CO	CL=10pf	0.2	1.0	—	μs
Row R0 ~ R4 Propagation Delay (Load-Rn)	tPDRO	CL=10pf	—	—	10.0	μs
Row R0~R4 Rise Time (Rn)	tr RO	CL=10pf	0.4	2.0	—	μs
Row R0~R4 Fall Time (Rn)	tf RO	CL=10pf	0.4	2.0	—	μs



TOSHIBA Bi-CMOS Integrated Circuit Silicon Monolithic

TB62713N/F

Recommended Operating Conditions:

CHARACTERISTICS	SYMBOL	CONDITION	MIN.	TYP.	MAX.	UNIT
-----------------	--------	-----------	------	------	------	------

Output Stage

Supply Voltage	VCC		4.0	—	15.0	V
Column C0~C6 Output Current	ICO	VCE=0.7V	—	—	50	mA
Row R0~R4 Output Current	IRO	VOUT=3.0V	—	—	-280	mA

Logic

Supply Voltage	VDD		4.5	—	5.5	V
High Level Input Current	I _{IH}	Data-In, Load&Clock, V _{IN} =VDD	—	—	1	μA
Low Level Input Current	I _{IL}	Data-In, Load&Clock, V _{IN} =0V	—	—	-1	μA
High Level Input Voltage	V _{IH}		0.7 VDD	—	—	V
Low Level Input Voltage	V _{IL}		—	—	0.3 VDD	V

Switching Condition

Data Hold Time (D-IN Clock)	t _{DHO}		30	—	—	ns
Data Setup Time (D-IN Clock)	t _{DST}		50	—	—	ns
Propagation Delay (Clock D-Out)	t _{PDSO}	CL=10pf	50	—	—	ns
High Level Pulse Width Of Clock	t _{CLKH}		30	—	—	ns
Low Level Pulse Width Of Clock	t _{CLKL}		30	—	—	ns
Pulse Width Of Load	t _{wLD}		150	—	—	ns
Setup Time (Clock-Load)	t _{CLKLD}		100	—	—	ns
Setup Time (Load-Clock)	t _{LDCCLK}		100	—	—	ns

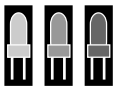

marktech
optoelectronics

120 Broadway • Menands, New York 12204

Toll Free: (800) 98-4LEDS • Fax: (518) 432-7454

TOSHIBA Bi-CMOS Integrated Circuit Silicon Monolithic



TB62713N/F

Terminal Description:

PIN No.	NAME	FUNCTION
1	V _{DD}	Logic Supply Voltage
2	Data IN	Serial Data Input To Shift Register
3	Clock (CLK)	Clock Input Terminal
4	Load (LD)	Load Input Terminal
5-11	Row R0-R6	Output Terminal to Row Cathodes
12	P-GND	GND for Row Out
13	Test In 2	Test Terminal - Grounded During Normal Operation
14	Test In 1	Test Terminal - Grounded During Normal Operation
5-17,19,2	Column C0-C4	Output Terminal to Column Anodes
18	V _{CC}	Supply Voltage For LEDs
21	Test OUT	During Normal Operation Leave open
22	Rext	Constant Current Programming Terminal
23	Data Out (DO)	Cascade Connection To Next Display Stage
24	L-GND	Logic & Analog Ground Terminal

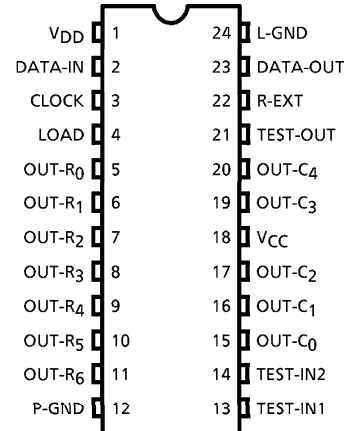

Timing Diagram:

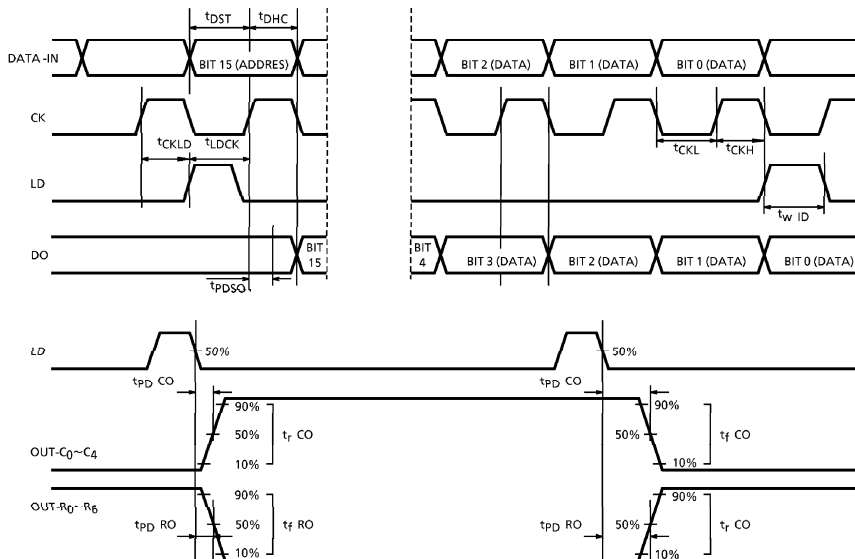

120 Broadway • Menands, New York 12204
Toll Free: (800) 98-4LEDS • Fax: (518) 432-7454

For up-to-date product info visit our web site at www.marktechopto.com

All specifications subject to change.



TOSHIBA Bi-CMOS Integrated Circuit Silicon Monolithic

TB62713N/F

Data Input

Data is input on the SERIAL-IN terminal. Each 16 bit serial word includes an address (D8 - D15) and data (D0 - D7). A low to high transition load command on the LOAD terminal loads the data into the appropriate registers following the 16th clock pulse.

Operation

Serial data is input on the DATA-IN terminal beginning with the most significant bit (MSB). Data is clocked through the 16 bit shift register on the rising edge of the clock. A Low to High transition on the LOAD input following the 16th (LSB) bit latches the 16 bit word into the 16 bit D-type latch.

Each 16 bit word typically includes 8 address bits and 8 data bits. The first four data bits, beginning with D15 (MSB) ~ D12 select the Action mode (see figure 1). These global commands determine the overall function the device is to perform and includes Blank, Normal Operation, Load Register, All On and Stand-by. Data bits D11~D8 select the particular register to be loaded (see figure 2) should the load register function be selected. Data bits D7~D0 (LSB) define the specific commands required to program the display and define the brightness setting (duty cycle).

Figure 1. Action Mode

FUNCTION	REGISTER DATA								INITIAL STATE
	D15	D14	D13	D12	D11~D8	D7~D4	D3~D0	Hex Code	
Blank (Rows & Columns All Off)	0	0	0	0	—	—	—	0 --- H	⇐
Normal Operation	0	0	0	1	—	—	—	1 --- H	
Load Register (Duty, Character Data)	0	0	1	X	X	X	X	2 xxx H	
All On (Col. C0~C4 All On)	0	0	1	1	—	—	—	3 --- H	
Stand-By	0	1	0	0	—	—	X	4 --- H	

“x” indicates that data is required in this field to execute the function. “-” indicates that data in this field is not required and not recognized.



marktech
optoelectronics

120 Broadway • Menands, New York 12204

Toll Free: (800) 98-4LEDS • Fax: (518) 432-7454



TB62713N/F

Action Mode

- 1. Blank** - Constant current segment drivers are off resulting in an all segments off condition. Data D15 ~ D12 are 0. D11~D0 are not relevant in blank mode. (Note: the device draws < 12.5ma in Blank mode.)
- 2. Normal (Operation)** - Instructs device to display data loaded during previous steps. D11~ D0 are not relevant in the Normal Operation mode.
- 3. Load Register** - Directs the device to recognize and load D11~ D0. In this mode D11 ~ D8 determines the specific register to be loaded (see figure 2) and D7 ~ D0 serves as the actual data to be loaded for programming the brightness (duty cycle) or the particular digit.
- 4. All On** - All constant current row drivers are on resulting in an all dots illuminated condition. D11 ~ D0 are not relevant in this mode.
- 5. Stand By** - All display drivers off condition. The Stand-By command turns off all internal bias currents and serves as a low power consumption mode (<.2ma). Used with Stand-By set up commands "All Data Clear" or "Data Not Cleared" (table 7).

The initial state, upon power up, is the BLANK state.

Application Note:

Stand-By and Blank perform similar functions in that the display is totally blank when either command is input. Stand-By provides a low power consumption (<.2ma current draw on V_{DD}) mode by turning off all internal bias currents in the internal driver circuits. The Stand-By command also cuts off the Rext bias current used to regulate the programmed constant current within the device.



TOSHIBA Bi-CMOS Integrated Circuit Silicon Monolithic

TB62713N/F

LOAD REGISTER Mode

Figure 2. LOAD REGISTER Mode

FUNCTION	REGISTER DATA							Hex Code
	D15~D12	D11	D10	D9	D8	D7~D4	D3~D0	
Load Duty Register	2H	0	0	0	0	X	X	20XXH
Load Character Data Register	2H	0	0	0	1	X	X	21XXH

“x” indicates that data is required in this field to execute the function. “-” indicates that data in this field is not required and not recognized.

Selects the specific register to be loaded. The LOAD REGISTER mode is enabled by the Load Register Action mode command (see Figure 1 - Action mode).

- 1. Duty Register** - Enables the device to accept duty cycle (brightness) setting. (see table 3 - Duty Cycle control register). Sixteen brightness steps (0/16 to 15/16) are available.
- 2. Character Data Register** - Enables the device to accept the data to program the 5 X 7 matrix character as encoded in D7~D0.

TOSHIBA Bi-CMOS Integrated Circuit Silicon Monolithic



TB62713N/F

Brightness Control

Brightness is controlled by controlling the “on time” duty cycle. The device allows for 16 brightness as illustrated in list 3 with 0/16 as the dimmest setting (not illuminated) to 15/16 as the brightest setting. The duty cycle control register is addressed with a 20 Hex command at D15~D8 and the appropriate data per list 3 at D3~D0. D7~D4 are not recognized by the duty cycle register. The initial state, upon power up is 15/16, or full brightness.

DUTY CYCLE	REGISTER DATA							INITIAL STATE
	D15~D8	D7~D4	D3	D2	D1	D0	Hex Code	
0/16	20H	—	0	0	0	0	20X0H	
1/16	20H	—	0	0	0	1	20X1H	
2/16	20H	—	0	0	1	0	20X2H	
3/16	20H	—	0	0	1	1	20X3H	
4/16	20H	—	0	1	0	0	20X4H	
5/16	20H	—	0	1	0	1	20X5H	
6/16	20H	—	0	1	1	0	20X6H	
7/16	20H	—	0	1	1	1	20X7H	
8/16	20H	—	1	0	0	0	20X8H	
9/16	20H	—	1	0	0	1	20X9H	
10/16	20H	—	1	0	1	0	20XAH	
11/16	20H	—	1	0	1	1	20XBH	
12/16	20H	—	1	1	0	0	20XCH	
13/16	20H	—	1	1	0	1	20XDH	
14/16	20H	—	1	1	1	0	20XEH	
15/16	20H	—	1	1	1	1	20XFH	←

“x” indicates that data is required in this field to execute the function. “-” indicates that data in this field is not required and not recognized.



TOSHIBA Bi-CMOS Integrated Circuit Silicon Monolithic

TB62713N/F

STAND-BY Commands

Two STAND-BY commands are available as illustrated in Table 7. STAND-BY / NO DATA CLEAR places the device in a power save mode (see application note - ACTION Mode section) while leaving data intact in the various registers. This mode is enabled by a 4 Hex command at D15~D12 and 0 Hex at D3~D0. D11~D4 are not relevant in the STAND-BY / NO DATA CLEAR Mode.

STAND-BY / DATA CLEAR also places the device in a power save mode and clears data in the various registers leaving registers in their initial state. This mode is enabled by a 4 Hex command at D15~D12 and 1 Hex at D3~D0. D11~D4 are not relevant in the STAND-BY / NO DATA CLEAR Mode.

	REGISTER DATA						
	D15~D8	D7~D4	D3	D2	D1	D0	Hex Code
Stand-By (No Data Clear)	4-H	—	0	0	0	0	4XX0H
Stand-By (Clear Data)	4-H	—	0	0	0	1	4XX1H

“x” indicates that data is required in this field to execute the function. “-” indicates that data in this field is not required and not recognized.



marktech
optoelectronics

120 Broadway • Menands, New York 12204

Toll Free: (800) 98-4LEDS • Fax: (518) 432-7454

TOSHIBA Bi-CMOS Integrated Circuit Silicon Monolithic



TB62713N/F

Operation example.

The following example begins with a blank display. Step 1 sets the brightness setting to maximum brightness (15/16 duty cycle). The next step instructs the device to display the character **A**. Step 4 instructs the device to display the character **B**. The next four steps (steps 5 - 8) display the characters **C, D, E** and **F** in sequence, all at full brightness. Step 9 blanks but does not clear the display and step 10 reprograms the brightness to half (8/16 duty cycle) brightness. Step 11 again displays the character **F** at half brightness. Step 12 again blanks the device and step 13 programs the character **G**. Step 14 instructs the device to display the character **G** (still at the half brightness setting) and step 15 clears and blanks the display.

STEP	D15-D12	D11-D8	D7-D4	D3-D0	OUTPUT R0-R6	OUTPUT C0-C4	MODE	DISPLAY INDICATION
0	—	—	—	—	Off	Off	Initial State (Clear Mode)	All Blank
1	0010	0000	XXXX	1111	Off	Off	Duty=15/16	All Blank
2	0010	0001	0100	0011	Off	Off	Character Data = A	All Blank
3	0001	XXXX	XXXX	XXXX	Off	On	Normal	A
4	0010	0001	0100	0010	On	On	Character Data = B	B
5	0010	0001	0100	0011	On	On	Character Data = C	C
6	0010	0001	0100	0100	On	On	Character Data = D	D
7	0010	0001	0100	0101	On	On	Character Data = E	E
8	0010	0000	0100	0110	On	On	Character Data = F	F
9	0000	XXXX	XXXX	XXXX	Off	Off	Blank	All Blank
10	0010	0000	XXXX	1000	Off	Off	Duty=8/16	All Blank
11	0001	XXXX	XXXX	XXXX	On	On	Normal	F - Half Brightness
12	0000	XXXX	XXXX	XXXX	Off	Off	Blank	All Blank
13	0010	0000	0100	0111	Off	Off	Character Data = G	All Blank
14	0001	XXXX	XXXX	XXXX	On	On	Normal	G - Half Brightness
15	0100	XXXX	XXXX	0000	Off	Off	Stand-By (Shut Down)	All Blank



TOSHIBA Bi-CMOS Integrated Circuit Silicon Monolithic

TB62713N/F

State Movement Diagram

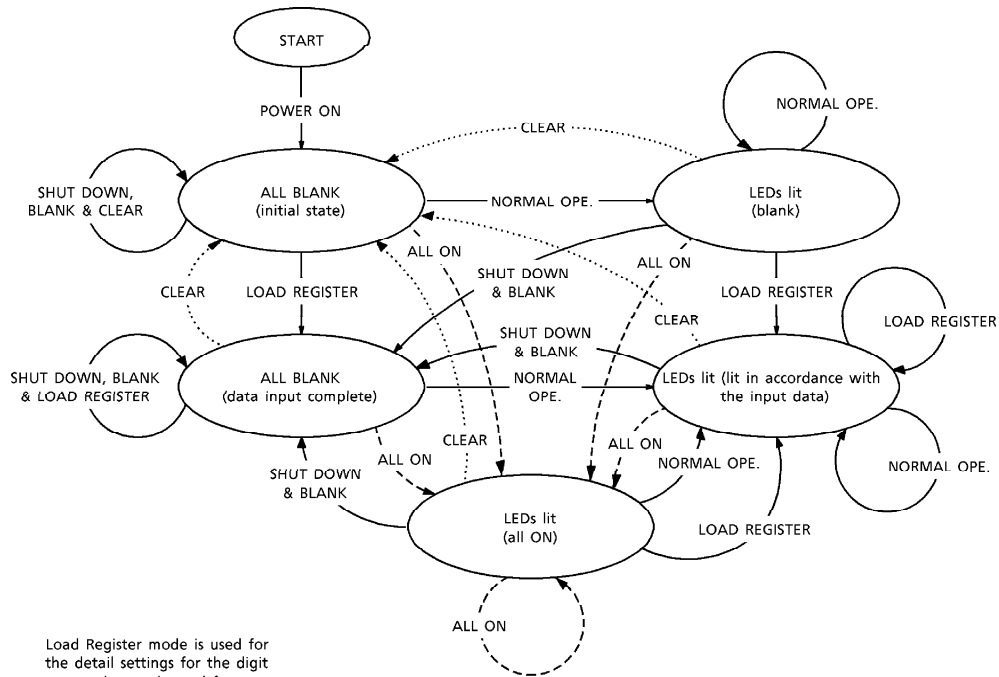

Load Register mode is used for the detail settings for the digit output duty cycle, and for inputting display data.

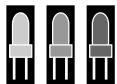

marktech
optoelectronics

120 Broadway • Menands, New York 12204

Toll Free: (800) 98-4LEDS • Fax: (518) 432-7454

TOSHIBA Bi-CMOS Integrated Circuit Silicon Monolithic



TB62713N/F

Character Generator List

- Character (ASCII) generator decoding
As the following table shows, the characters are decoded using combinations of the data in D₀ to D₇.

Table 6.1 List of ASCII character set decoding data

D ₇	D ₆	D ₅	D ₄	HEX	0	1	2	3	4	5	6	7	8	9	A	B	C	D	E	F	
0	0	0	0	0	0	1	0	1	0	0	1	0	1	0	1	0	1	0	1	0	1
0	0	0	0	1	0	1	1	0	0	0	1	1	0	0	1	1	0	0	1	1	0
0	0	0	1	1	0	0	0	1	1	1	1	0	0	0	1	1	0	0	1	1	1
0	0	1	0	0	0	0	0	0	0	0	0	0	1	1	1	1	1	1	1	1	1
0	0	1	0	1	0	1	2	3	4	5	6	7									
0	0	1	1	0	0	1	0	1	0	1	0	1									
0	0	1	1	1	0	1	1	0	1	1	1	0									
0	0	1	1	1	1	0	1	1	1	1	1	1									
0	1	0	0	0	0	1	0	1	0	1	0	1									
0	1	0	0	1	0	1	1	0	1	1	1	1									
0	1	0	1	0	1	1	1	1	1	1	1	1									
0	1	1	0	0	0	1	0	1	0	1	0	1									
0	1	1	0	1	1	1	1	1	1	1	1	1									

See Table 6.2.

TB62713N/F-11



TOSHIBA Bi-CMOS Integrated Circuit Silicon Monolithic

TB62713N/F

Character Generator List

Table 6.2 List of ASCII character set decoding data

D7	D6	D5	D4	D3	D2	D1	D0	HEX	8	9	A	B	C	D	E	F								
0	0	0	0	0	0	0	0	0	0	1	0	1	0	1	0	1								
0	0	0	0	0	0	0	0	1	0	0	1	1	0	0	1	1								
0	0	0	0	0	0	0	0	1	0	0	0	0	1	1	1	1								
0	0	0	0	0	0	0	0	1	1	1	1	1	1	1	1	1								
0	0	0	0	1	2	3	4	5	6	7	8	9	A	B	C	D								
0	0	0	0	0	0	0	0	0	See Table 6.1.															
0	0	0	0	0	0	0	0																	
0	0	0	0	1	1	1	1																	
0	0	0	1	0	2	2	2																	
0	0	1	1	3	3	3	3																	
0	1	0	0	4	4	4	4																	
0	1	0	1	5	5	5	5																	
0	1	1	0	6	6	6	6																	
0	1	1	1	7	7	7	7																	

TB62713N/F-12

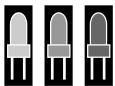

marktech
optoelectronics

120 Broadway • Menands, New York 12204

Toll Free: (800) 98-4LEDS • Fax: (518) 432-7454

TOSHIBA Bi-CMOS Integrated Circuit Silicon Monolithic



TB62713N/F

Test Circuit:

(1) I_{CC1} , I_{CC2}

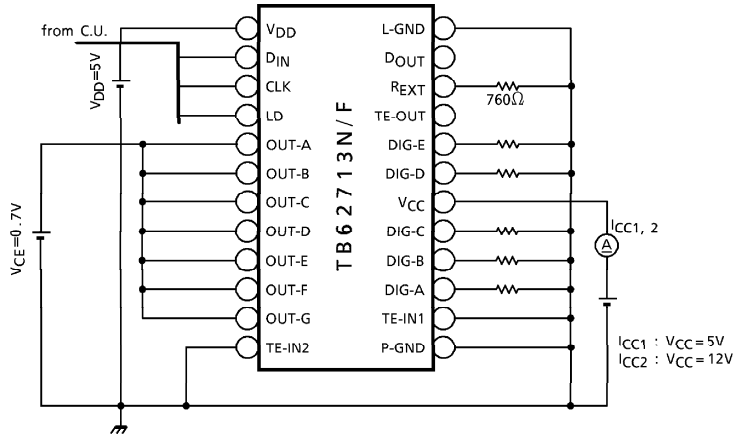

(2) f_{osc}

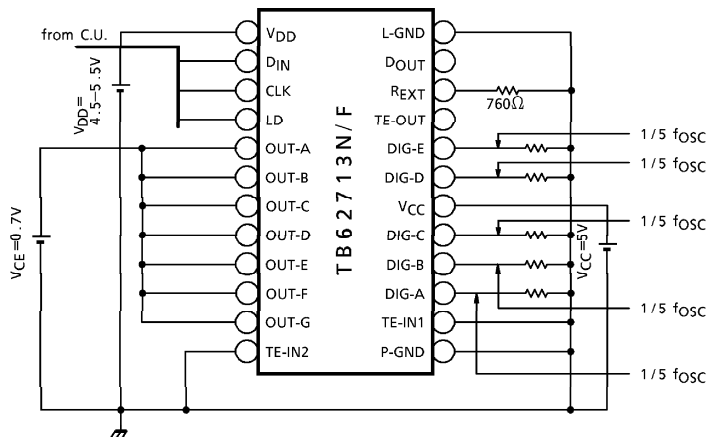



TOSHIBA Bi-CMOS Integrated Circuit Silicon Monolithic

TB62713N/F

Test Circuit:

(3) I_{SEG}

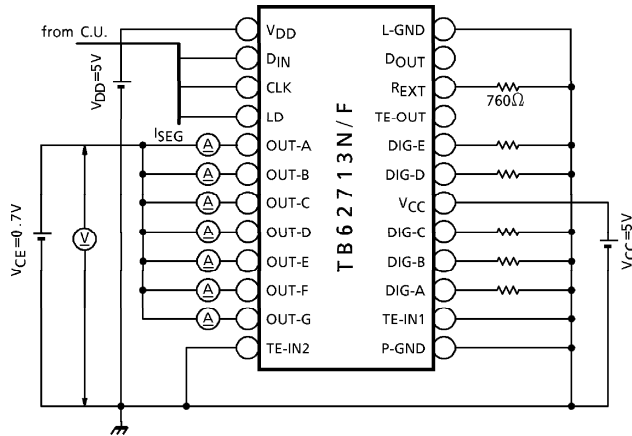

(4) I_{leak1} , I_{leak2}

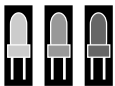
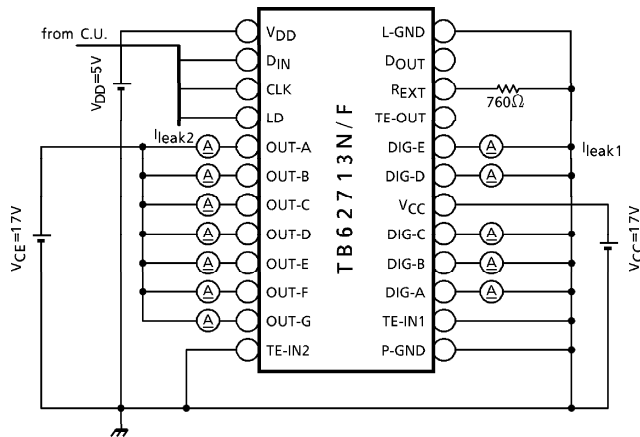

marktech
optoelectronics

120 Broadway • Menands, New York 12204

Toll Free: (800) 98-4LEDS • Fax: (518) 432-7454

TOSHIBA Bi-CMOS Integrated Circuit Silicon Monolithic



TB62713N/F

Test Circuit:

(5) V_{OUT}

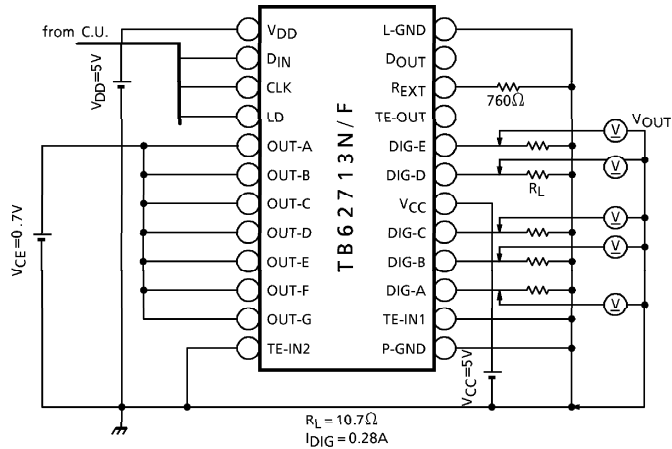

(6) I_{DD1} , I_{DD2} , I_{DD3} , V_{OH1} , V_{OH2} , V_{OL1} , V_{OL2} , f_{CLK}

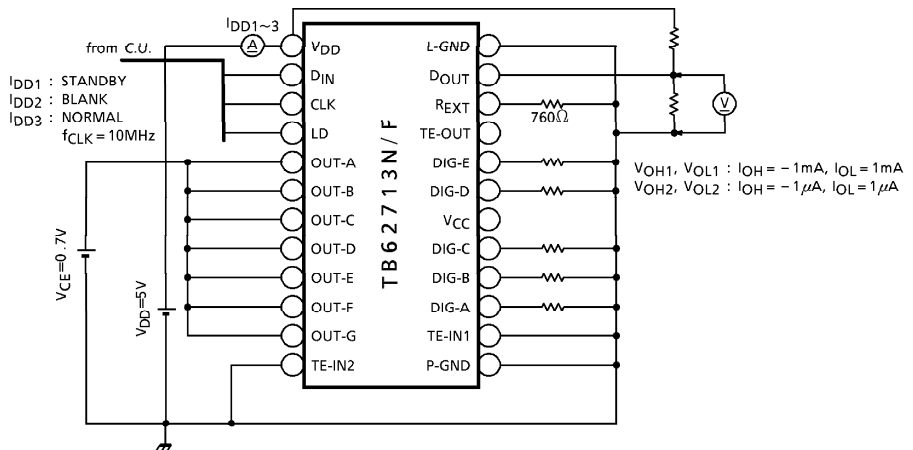



TOSHIBA Bi-CMOS Integrated Circuit Silicon Monolithic

TB62713N/F

Graphs:

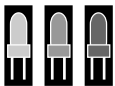
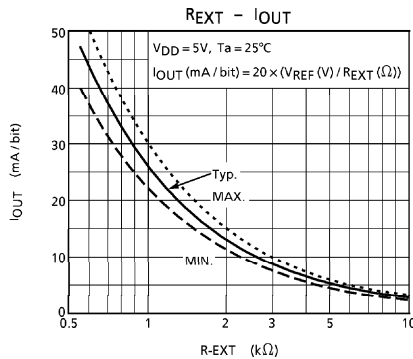
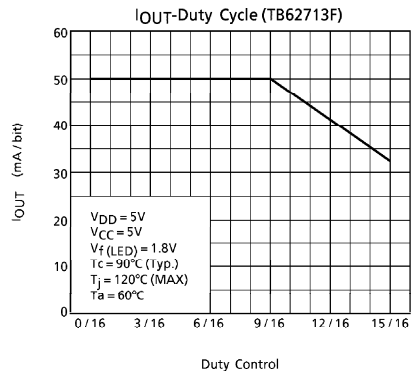
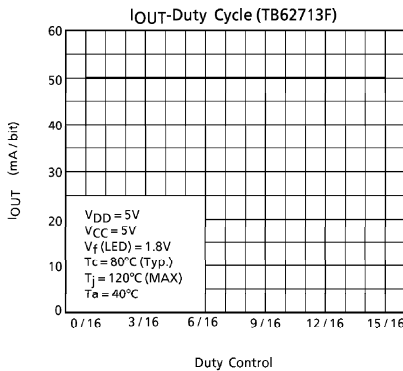
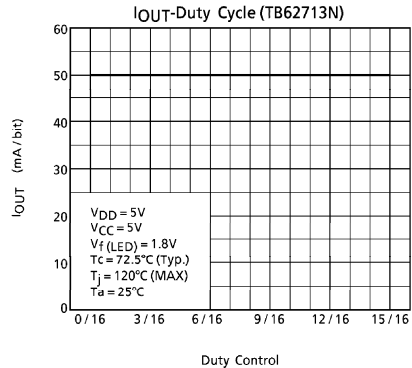
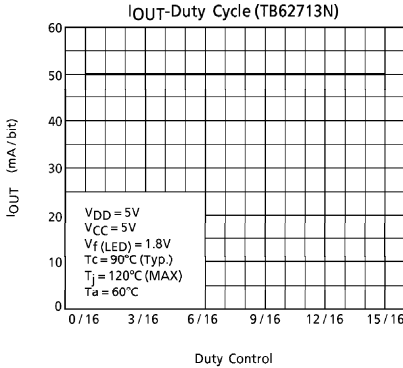

marktech
optoelectronics

120 Broadway • Menands, New York 12204

Toll Free: (800) 98-4LEDS • Fax: (518) 432-7454

TOSHIBA Bi-CMOS Integrated Circuit Silicon Monolithic



TB62713N/F

Outline Drawings:

SDIP24-P-300-1.78

Unit : mm

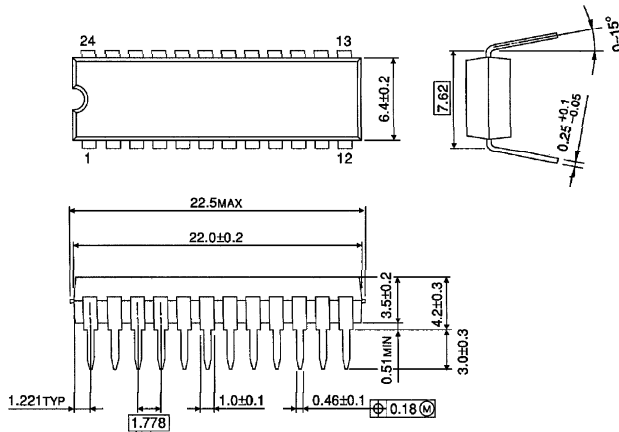

Weight : 1.62g (Typ.)

SSOP24-P-300-1.00

Unit : mm

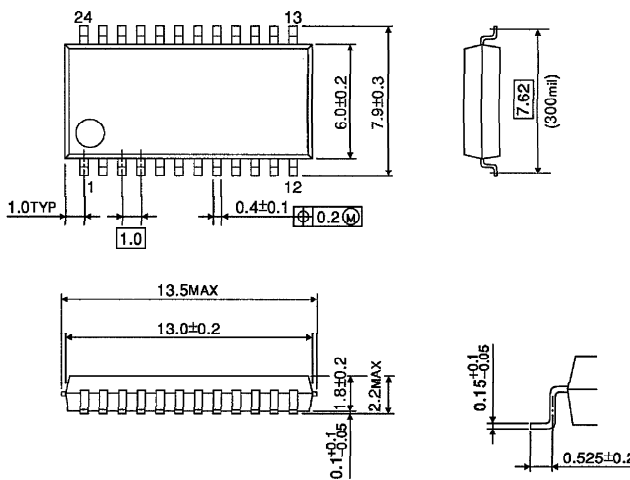

Weight : 0.32g (Typ.)



120 Broadway • Menands, New York 12204
Toll Free: (800) 98-4LEDS • Fax: (518) 432-7454

For up-to-date product info visit our web site at www.marktechopto.com

All specifications subject to change.