

3V LOGIC OUTPUT TEMPERATURE SENSOR WITH PROGRAMMABLE HYSTERESIS

FEATURES

- User Programmable Hysteresis and Temperature Set Point
- Easily Programs with Two External Resistors
- Wide Temperature Detection Range
 - TC07CxA 0°C to +70°C
 - TC07ExA -40°C to +85°C
 - TC07VxA -40°C to +125°C
- Small 8-Pin MSOP and 8-Pin SOIC Packages
- Cost Effective

APPLICATIONS

- Power Supply Over-Temperature Detection
- Consumer Equipment
- Temperature Regulators
- Computer Equipment

ORDERING INFORMATION

Part No.	Package	Temp. Range
TC07COA	8-Pin SOIC	0°C to +70°C
TC07CUA	8-Pin MSOP	0°C to +70°C
TC07EOA	8-Pin SOIC	-40°C to +85°C
TC07EUA	8-Pin MSOP	-40°C to +85°C
TC07VOA	8-Pin SOIC	-40°C to +125°C
TC07VUA	8-Pin MSOP	-40°C to +125°C

FUNCTIONAL BLOCK DIAGRAM

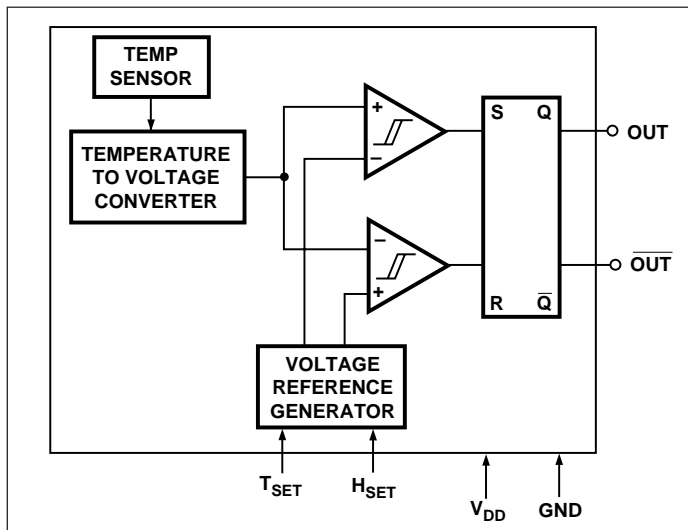

GENERAL DESCRIPTION

The TC07 is a programmable, logic output temperature detector that operates from power supply levels as low as 2.7V. Programming is accomplished with external resistors connected from the temperature setpoint input (T_{SET}) and the hysteresis control input (H_{SET}) to V_{DD}.

Complimentary outputs (OUT and $\overline{\text{OUT}}$) are driven active when temperature exceeds the temperature threshold programmed by the resistor on T_{SET}. The states of these outputs are maintained (latched) until temperature falls below threshold programmed by the resistor on H_{SET}.

The TC07 is useful over a maximum temperature range of -40°C to +125°C (TC07VxA). It features low (<130μA) supply current and small physical size 8-pin MSOP and 8-pin SOIC packages, making it suitable for a wide variety of applications.

PIN CONFIGURATION

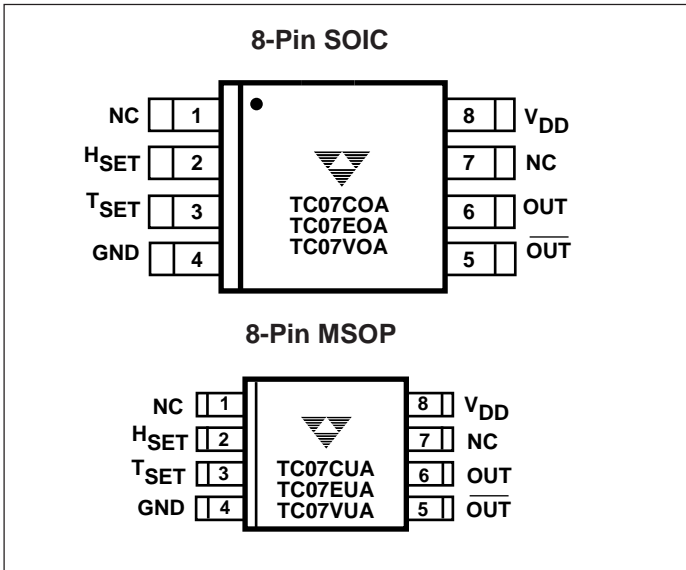

3V LOGIC OUTPUT TEMPERATURE SENSOR WITH PROGRAMMABLE HYSTERESIS

TC07

ABSOLUTE MAXIMUM RATINGS*

Supply Voltage	7V
Input Voltage Any Input	(GND – 0.3V) to (V _{DD} + 0.3V)
Operating Temperature	– 40°C to +125°C
Maximum Chip Temperature	+150°C
Storage Temperature	– 65°C to +150°C
Lead Temperature (Soldering, 10 sec)	+300°C

* Stresses above those listed under "Absolute Maximum Ratings" may cause permanent damage to the device. These are stress ratings only and functional operation of the device at these or any other conditions above those indicated in the operation sections of the specifications is not implied. Exposure to absolute maximum rating conditions for extended periods may affect device reliability.

ELECTRICAL CHARACTERISTICS: T_A = Over Operational Temperature Range, unless otherwise specified.

Symbol	Parameter	Conditions	Min	Typ	Max	Unit
V _{DD}	Supply Voltage Range		2.7	—	5.5	V
I _{DD}	Supply Current	2.7V < V _{CC} < 5.5V	—	130	300	μA
V _{OH}	Output Voltage (High)	I _{OUT} = 500μA	0.8 x V _{DD}	—	—	V
V _{OL}	Output Voltage (Low)	I _{OUT} = 1mA	—	—	0.25 x V _{DD}	V
H	Minimum Hysteresis	H _{SET} < T _{SET}	– 5	—	—	°C
T _{SET}	Absolute Accuracy	T = Programmed Temperature	T – 3	T ± 1	T + 3	°C
H _{SET}	Absolute Accuracy	T = Programmed Temperature	T – 5	T ± 1	T + 5	°C

DETAILED DESCRIPTION

The TC07 programs with resistors connected from the T_{SET} and H_{SET} inputs to V_{DD}. Output pins OUT and $\overline{\text{OUT}}$ are driven active when temperature exceeds the setting determined by the programming resistor on T_{SET}. The outputs are maintained (latched) in their active states until temperature drops below the setting determined by the programming resistor on H_{SET} (Figure 1).

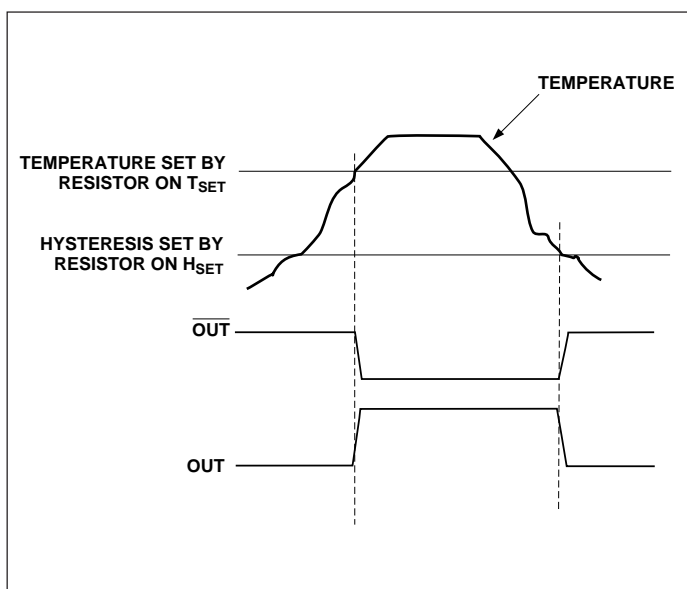

Figure 1. TC07 Output Waveforms

APPLICATIONS

Trip Point Programming

The resistor values required to achieve the desired trip-point temperatures on T_{SET} and H_{SET} are calculated using the formula below:

$$R_{\text{TRIP}} = 0.6 \times T^{2.13}$$

Where:

- R_{TRIP} = Programming resistor value in Ohms
- T = Desired trip point temperature in degrees Kelvin.

For example, to program the TC07 outputs to go active at 50°C and inactive at 30°C, the T_{SET} and H_{SET} programming resistors are calculated as follows:

$$T_{\text{SET}} = 0.6 \times ((50 + 273.15)^{2.13}) = 132.8\text{k}\Omega$$

$$H_{\text{SET}} = 0.6 \times ((30 + 273.15)^{2.13}) = 115.9\text{k}\Omega$$

Resistance values for T_{SET} and H_{SET} can be approximated using Figure 2. Care must be taken to ensure the H_{SET} programming resistor is a smaller value than the T_{SET} programming resistor. The temperature programmed on H_{SET} must be at least 5°C lower than the temperature value programmed by T_{SET}. That is: H_{SET} ≤ T_{SET} – 5°C.

3V LOGIC OUTPUT TEMPERATURE SENSOR WITH PROGRAMMABLE HYSTERESIS

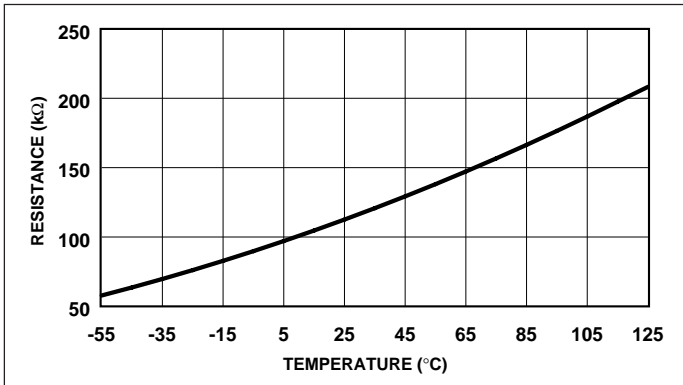

Figure 2. Programming Resistor Values vs. Temperature

Cooling and Heating Applications

The TC07 can be used to control a DC fan as shown in Figure 3. The fan turns on when the sensed temperature rises above T_{SET} and remains on until the temperature falls below H_{SET} . The amount of "over-cooling" performed by the fan is dependent on the programmed hysteresis.

Figure 4 shows the TC07 acting as a heater thermostat. Circuit operation is identical to that of the cooling fan application.

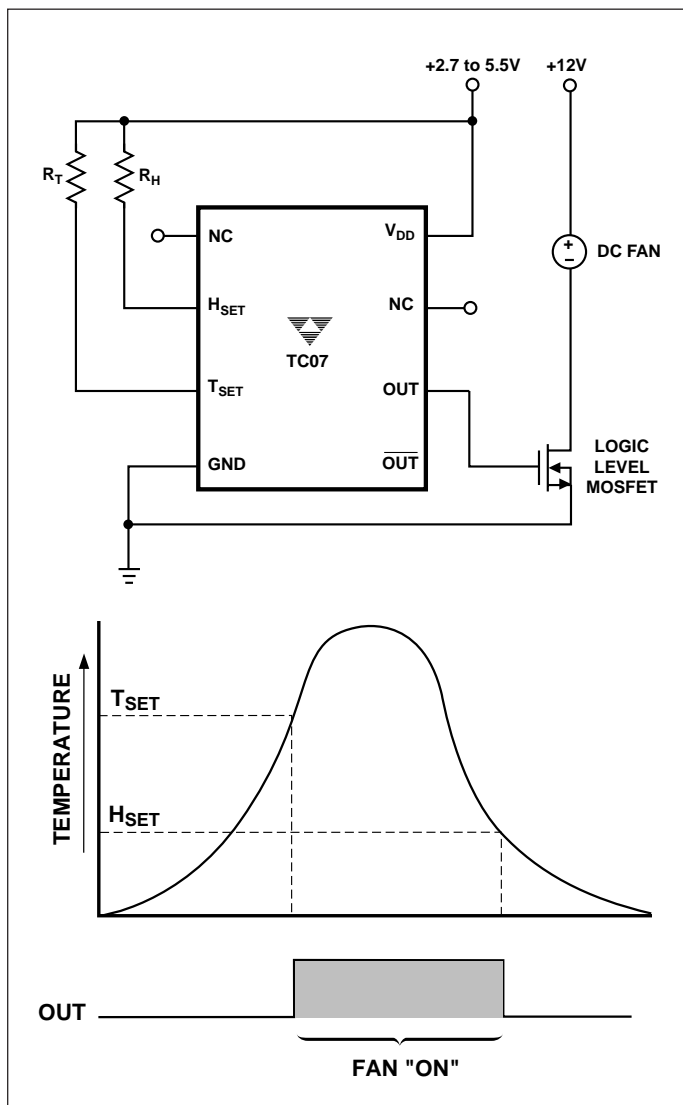

Figure 3. TC07 as a Fan Controller

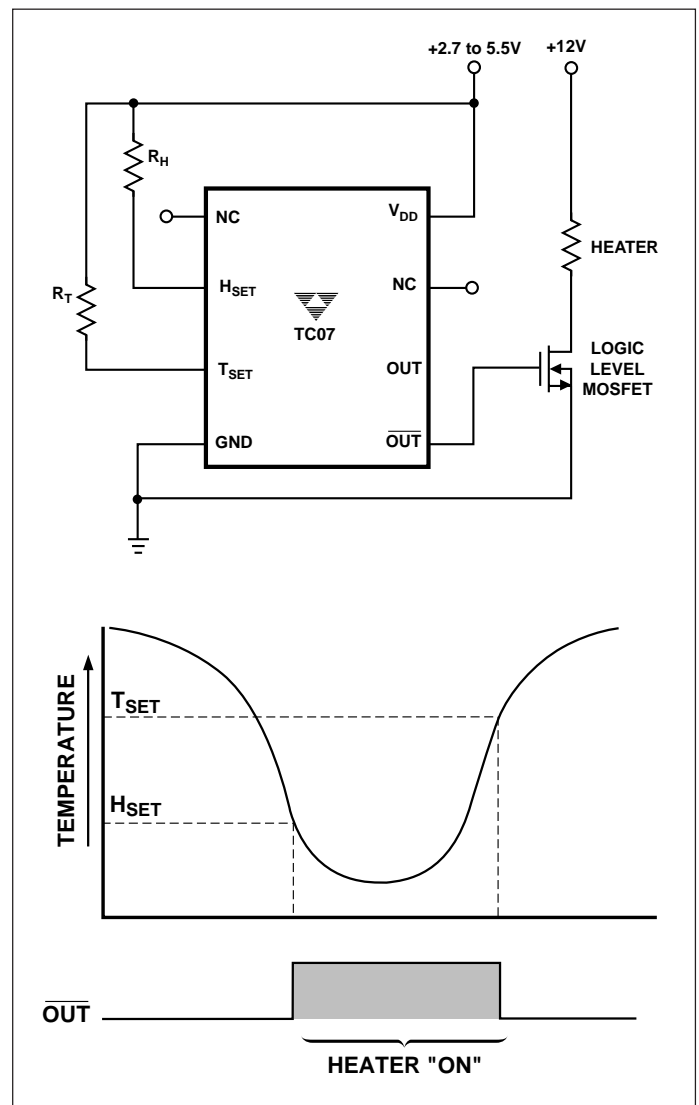

Figure 4. TC07 as a Heater Thermostat