

# 800mA LOW DROPOUT POSITIVE REGULATORS ADJUSTABLE AND FIXED 2.85V, 3.30V, 5.00V

## FEATURES

- Space-saving SOT-223 Package
- Pin Compatible with Older Adjustable 3 Terminal Regulators
- Adjustable or Fixed Voltages of 2.85V, 3.30V or 5.00V
- High Output Current ..... 800mA
- Low Dropout Voltage ..... 1.2V at I<sub>OUT</sub> = 800mA
- Guaranteed Dropout Voltage at Multiple Current Levels
- Line Regulation (Max) ..... 0.2%
- Load Regulation (Max) ..... 0.4%

## APPLICATIONS

- Active SCSI Terminators
- High Efficiency Linear Regulators
- Post Regulators for Switching Supplies
- Battery Chargers
- 5V - 3.3V Linear Regulators

## ORDERING INFORMATION

Part Number*	Package	Part Marking
TCL1117-ADJCDB	SOT-223-3	1117
TCL1117-2.85CDB	SOT-223-3	11172
TCL1117-3.30CDB	SOT-223-3	11173
TCL1117-5.00CDB	SOT-223-3	11175
TCL1117-ADJCEB	DDPAK-3	
TCL1117-2.85CEB	DDPAK-3	
TCL1117-3.30CEB	DDPAK-3	
TCL1117-5.00CEB	DDPAK-3	

\*Ambient temperature range is determined by maximum operating power dissipation and a maximum die temperature of 125°C (see Power Dissipation and Thermal Design Section).

## GENERAL DESCRIPTION

The TCL1117 is a low-dropout positive voltage regulator (LDO) with 800mA output current capability. It is available in fixed and adjustable output voltage versions, 2.85V (active SCSI terminators), 3.30V and 5.00V. Output/reference voltage accuracy is guaranteed to ±1.0%. Over-current protection is integrated onto the chip. Dropout is specified at 1.2V maximum at full rated output current and less than 1.0V at low loads (<100mA). The SOT-223 package makes the TCL1117 especially attractive for tight physical layouts. For stability, a 10µF output capacitor is required. The TCL1117 is an NPN-based design which has significantly lower unused quiescent current than similar PNP-based regulators.

## PIN CONFIGURATIONS

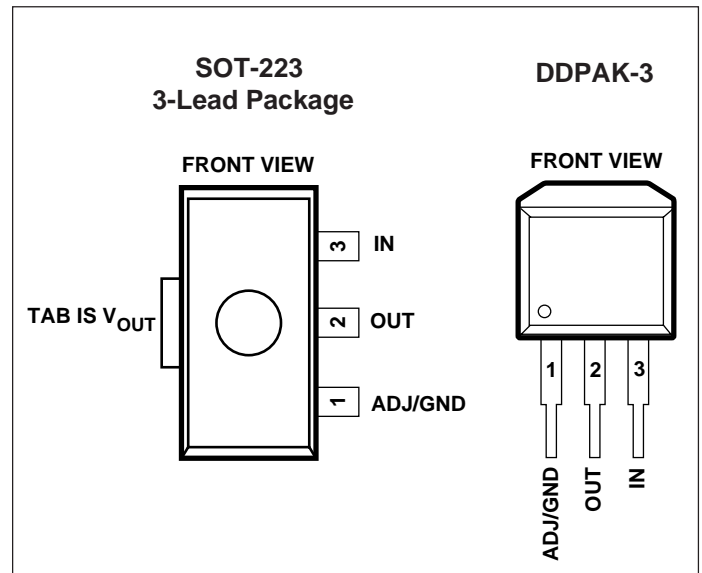

## TYPICAL APPLICATION

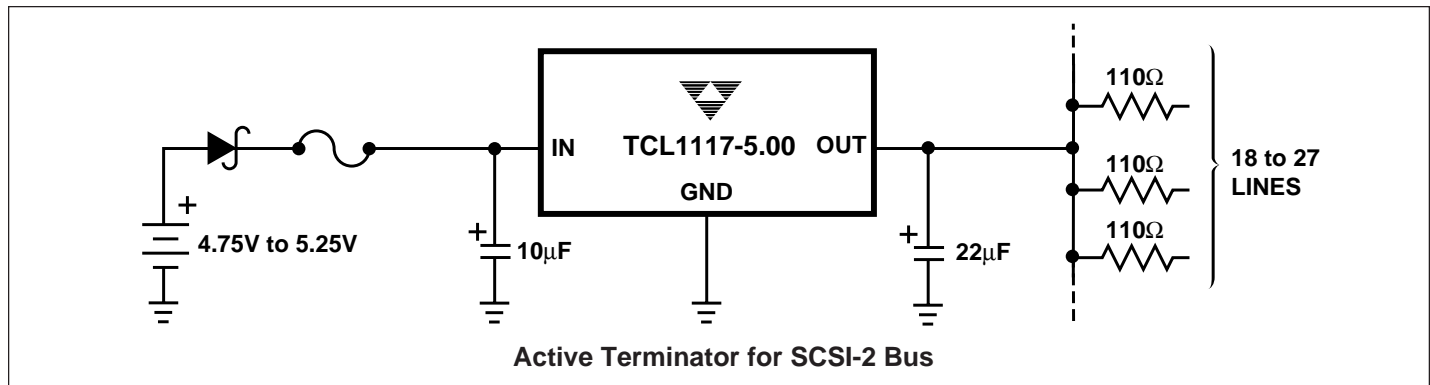

TCL1117  
TCL1117-2.85  
TCL1117-3.30  
TCL1117-5.00

**ABSOLUTE MAXIMUM RATINGS\***

Input Voltage

Operating Voltage:

TCL1117, TCL1117-3.30, TCL1117-5.00 ..... 15V

TCL1117-2.85 ..... 10V

Surge Voltage:

TCL1117, TCL1117-3.30, TCL1117-5.00 ..... 20V

Operating Junction Temperature ..... 0°C to +125°C

Storage Temperature ..... - 65°C to +150°C

Lead Temperature (Soldering 10 sec) ..... 300°C

\*Stresses beyond those listed under "Absolute Maximum Ratings" may cause permanent damage to the device. These are stress ratings only, and functional operation of the device at these or any other conditions beyond those indicated in the operational sections of the specifications is not implied. Exposure to absolute maximum rating conditions for extended periods may affect device reliability.

**ELECTRICAL CHARACTERISTICS**

Symbol	Parameter	Test Conditions	Min	Typ	Max	Unit
	Reference Voltage	TCL1117 $I_{OUT} = 10\text{mA}$ , $(V_{IN} - V_{OUT}) = 2\text{V}$ , $T_J = 25^\circ\text{C}$ $10 \leq I_{OUT} \leq 800\text{mA}$ , $1.4\text{V} \leq (V_{IN} - V_{OUT}) \leq 10\text{V}$ (Note 1)	1.238	1.250	1.262	V
			1.225	1.250	1.270	
	Output Voltage	TCL1117-2.85 $I_{OUT} = 10\text{mA}$ , $V_{IN} = 4.85\text{V}$ , $T_J = 25^\circ\text{C}$ $0 \leq I_{OUT} \leq 800\text{mA}$ , $4.25\text{V} \leq V_{IN} \leq 10\text{V}$ (Note 1) $0 \leq I_{OUT} \leq 500\text{mA}$ , $V_{IN} = 3.95\text{V}$ (Note 1)	2.820	2.850	2.880	V
			2.790	2.850	2.910	
			2.790	2.850	2.910	
	Output Voltage	TCL1117-3.30 $I_{OUT} = 10\text{mA}$ , $V_{IN} = 5.3\text{V}$ , $T_J = 25^\circ\text{C}$ $0 \leq I_{OUT} \leq 800\text{mA}$ , $4.75\text{V} \leq V_{IN} \leq 10\text{V}$ (Note 1)	3.265	3.300	3.335	V
			3.230	3.300	3.370	
	Output Voltage	TCL1117-5.00 $I_{OUT} = 10\text{mA}$ , $V_{IN} = 7\text{V}$ , $T_J = 25^\circ\text{C}$ $0 \leq I_{OUT} \leq 800\text{mA}$ , $6.50\text{V} \leq V_{IN} \leq 12\text{V}$ (Note 1)	4.950	5.000	5.050	V
			4.900	5.000	5.100	
	Line Regulation	TCL1117 $I_{OUT} = 10\text{mA}$ , $1.5\text{V} \leq V_{IN} - V_{OUT} \leq 15\text{V}$ (Notes 1 & 2)	—	0.035	0.2	% mV
		TCL1117-2.85 $I_{OUT} = 0\text{mA}$ , $4.25\text{V} \leq V_{IN} \leq 10\text{V}$ (Notes 1 & 2)	—	1	6	
		TCL1117-3.30 $I_{OUT} = 0\text{mA}$ , $4.75\text{V} \leq V_{IN} \leq 15\text{V}$ (Notes 1 & 2)	—	1	7	
		TCL1117-5.00 $I_{OUT} = 0\text{mA}$ , $6.5\text{V} \leq V_{IN} \leq 15\text{V}$ (Notes 1 & 2)	—	1	10	
	Load Regulation	TCL1117 $(V_{IN} - V_{OUT}) = 3\text{V}$ , $10\text{mA} \leq I_{OUT} \leq 800\text{mA}$ (Notes 1 & 2)	—	0.1	0.4	% mV
		TCL1117-2.85 $V_{IN} = 4.25\text{V}$ , $0 \leq I_{OUT} \leq 800\text{mA}$ (Notes 1 & 2)	—	1	10	
		TCL1117-3.30 $V_{IN} = 4.75\text{V}$ , $0 \leq I_{OUT} \leq 800\text{mA}$ (Notes 1 & 2)	—	1	12	
		TCL1117-5.00 $V_{IN} = 6.5\text{V}$ , $0 \leq I_{OUT} \leq 800\text{mA}$ (Notes 1 & 2)	—	1	15	
	Dropout Voltage	$I_{OUT} = 100\text{mA}$ , (Note 1 & 3) $I_{OUT} = 500\text{mA}$ , (Note 1 & 3) $I_{OUT} = 800\text{mA}$ , (Note 1 & 3)	—	1.00	1.10	V
			—	1.05	1.15	
			—	1.10	1.20	
	Current Limit	$(V_{IN} - V_{OUT}) = 5\text{V}$ , $T_J = 25^\circ\text{C}$	800	950	1200	mA
	Minimum Load Current	TCL1117 $(V_{IN} - V_{OUT}) = 15\text{V}$ (Note 1 & 4)	—	1.7	5	mA
	Quiescent Current	TCL1117-2.85 $V_{IN} \leq 10\text{V}$ (Note 1)	—	5	10	mA
		TCL1117-3.30 $V_{IN} \leq 15\text{V}$ (Note 1)	—	5	10	
		TCL1117-5.00 $V_{IN} \leq 15\text{V}$ (Note 1)	—	5	10	
	Thermal Regulation	$T_A = 25^\circ\text{C}$ , 30msec Pulse	—	0.01	0.1	%W
	Ripple Rejection	$f_{RIPPLE} = 120\text{Hz}$ $(V_{IN} - V_{OUT}) = 3\text{V}$ , $V_{RIPPLE} = 1\text{Vp-p}$ (Note 1)	60	75	—	dB
	Adjust Pin Current	(Note 1)	—	55	120	$\mu\text{A}$
	Adjust Pin Current Change	$10\text{mA} \leq I_{OUT} \leq 800\text{mA}$ , $1.4\text{V} \leq (V_{IN} - V_{OUT}) \leq 10\text{V}$ (Note 1)	—	0.2	5	$\mu\text{A}$
	Temperature Stability		—	0.5	—	%
	Long Term Stability	$T_A = 125^\circ\text{C}$ , 1000 Hrs.	—	0.3	—	%
	RMS Output Noise	(% of $V_{OUT}$ ), $10\text{Hz} \leq f \leq 10\text{kHz}$	—	0.003	—	%
	Thermal Resistance	(Junction to Case, at Tab)	—	15	—	$^\circ\text{C/W}$

- NOTES:**
- Specifications apply over the full operating temperature range.
  - See thermal regulation specification for changes in output voltage due to heating effects. Load regulation and line regulation are measured at a constant junction temperature by low duty cycle pulse testing.
  - Dropout voltage is specified over the full output current range of the device. Dropout voltage is defined as the minimum input/output differential measured at the specified output current. Test points and limits are also shown on the Dropout Voltage curve.
  - Minimum load current is defined as the minimum output current required to maintain regulation.

## APPLICATIONS

### Overload Protection

The TCL1117 is protected against current (short-circuit) and thermal overload conditions. Thermal protection is triggered by a chip temperature exceeding 165°C. Current overload is triggered at approximately 950mA.

### Stability and Load Regulation

The TCL1117 requires a capacitor from  $V_{OUT}$  to GND to provide compensation feedback to the internal gain stage. This is to ensure stability at the output terminal. Typically, a 10µF tantalum or 50µF aluminum electrolytic is sufficient. NOTE: It is important that the ESR for this capacitor does not exceed 0.5Ω.

The output capacitor does not have a theoretical upper limit and increasing its value will increase stability.  $C_{OUT} = 100\mu\text{F}$  or more is typical for high current regulator designs. NOTE: See Protection Diodes for limitations. Another benefit of larger output capacitance is improved transient load response (large di/dt in the load).

### Protection Diodes

Typically no protection diodes are necessary for the TCL1117. Unlike older regulators, the ADJ pin is protected internally from excessive currents. The ADJ pin can be driven with voltage transients as high as ±25V with respect to the output without damage to the device.

Likewise, a diode between the input and output is not typically required. If the input voltage collapses the internal circuitry can absorb ~20A transient currents (<10µsec) without damage. This reverse current is much larger than most power supply designs can generate. However, if the output capacitor is VERY large (>1000µF), instantaneous

currents can be high enough to damage the chip. In this case, a high-current, fast-response diode is recommended. (See Figure 1).

### Output Voltage Adjust

Like most LDOs, the TCL1117 regulates the output by comparing the output voltage, or a multiple thereof, to an internally generated reference voltage. On the adjustable version, the  $V_{REF}$  is available externally as 1.25V (±1%) between  $V_{OUT}$  and ADJ (See Figure 2). The voltage divider formed by R1 and R2 should be set to conduct 10mA (minimum output load). The output voltage is given by the following equation:

$$V_{OUT} = V_{REF} \left( 1 + \frac{R_2}{R_1} \right) + I_{ADJ} R_2$$

On fixed voltage versions of the TCL1117, the voltage divider is provided internally.

### Load Regulation

The TCL1117 load regulation is limited by the resistance of the wire connecting it to the load ( $R_p$ , Figure 3). For the adjustable version, the best load regulation is accomplished when the top of the resistor divider (R1) is connected directly to the output pin of the TCL1117, NOT to the high side of the load (Figure 3). When so connected,  $R_p$  is not multiplied by the divider ratio. For the fixed output versions, the top of R1 is internally connected to the output and the ground pin can be connected to the low side of the load as a negative side sense if, so desired.

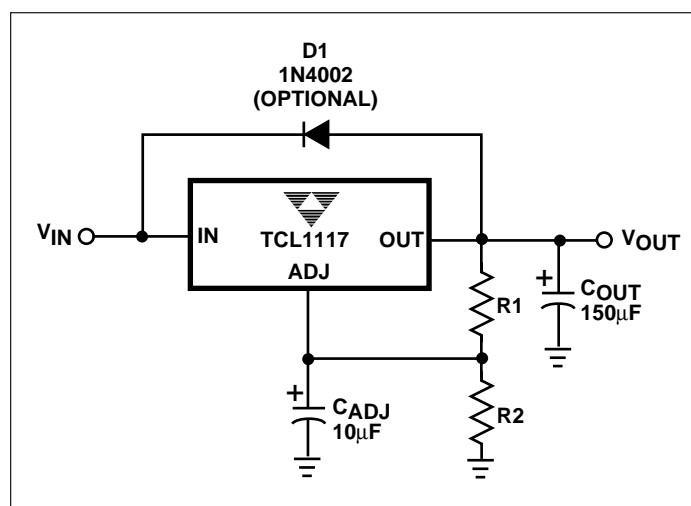

Figure 1.

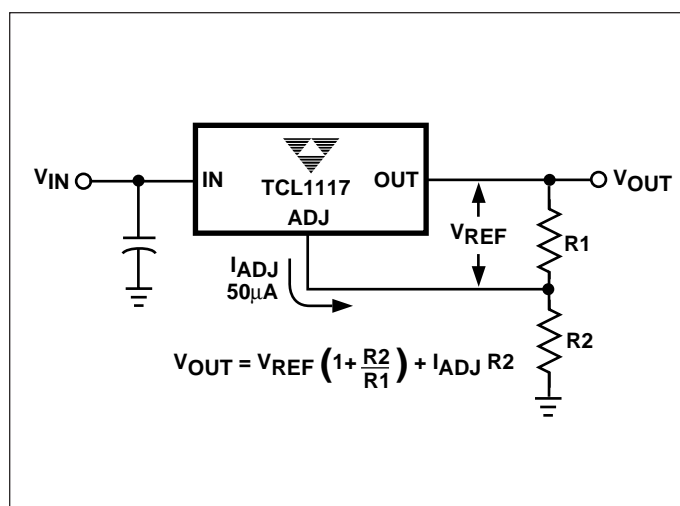

Figure 2. Basic Adjustable Regulator

TCL1117  
TCL1117-2.85  
TCL1117-3.30  
TCL1117-5.00

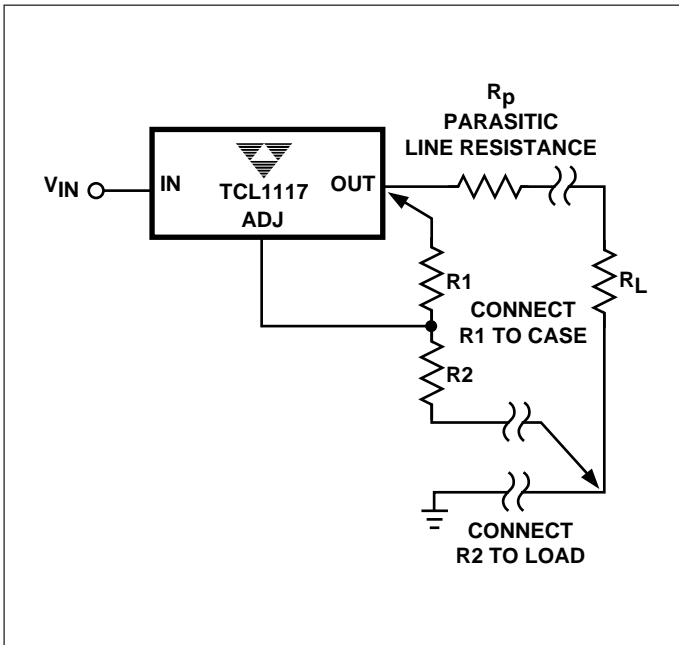

Figure 3. Connections for Best Load Regulation

### Power Dissipation and Thermal Design

As mentioned earlier, the TCL1117 has thermal over-load protection which limits internal temperature to +165°C. However, device functionality is only guaranteed to a maximum junction temperature of +125°C. Since internal power dissipation can be >1 watt, careful thermal design is essential. The TCL1117 is supplied in a SOT-223 package which is intended to be directly surface-mounted to the PC-board. Because there is no dedicated heat sink, power dissipation to ambient is performed largely by the PC board and its copper material.

The power dissipation and junction temperature for the TCL1117 in a SOT-223 are given by the following equations:

$$P_D = (V_{IN} - V_{OUT}) \times (I_{OUT})$$

$$T_{JUNCTION} = T_{AMBIENT} + (P_D \times \Theta_{JA})$$

NOTE:  $T_{JUNCTION}$  must not exceed 125°C

The  $\Theta_{JC}$  (junction to external tab) for the SOT-223 is 15°C/W. Depending upon heatsink parameters, the  $\Theta_{CA}$  can be as low as 30°C/W. Therefore, the total thermal resistance ( $\Theta_{JA}$ ) is at least 45°C/W. Table 1 shows thermal resistance measurements taken with the TCL1117 mounted on 1/16 inch 2-layer PCB with 1oz. copper foil. NOTE: The TAB pin does not have to be soldered to all copper layers for effective heat transfer. Use Table 1 only as a rough guide since thermal interactions with adjacent components cannot be predicted.

Table 1.

Copper Area		Board Area	Thermal Resistance (Junction-to-Ambient)
Topside*	Backside		
2500 Sq. mm	2500 Sq. mm	2500 Sq. mm	45°C/W
1000 Sq. mm	2500 Sq. mm	2500 Sq. mm	45°C/W
225 Sq. mm	2500 Sq. mm	2500 Sq. mm	53°C/W
100 Sq. mm	2500 Sq. mm	2500 Sq. mm	59°C/W
1000 Sq. mm	1000 Sq. mm	1000 Sq. mm	52°C/W
1000 Sq. mm	0	1000 Sq. mm	55°C/W

\*Tab of device attached to topside copper

### Soldering Methods

The recommended methods of soldering the SOT-223 package are: vapor phase re-flow and infrared re-flow with component preheat within 65°C of the solder temperature. Hand soldering and wave soldering methods are not recommended since they can damage the part with excessive thermal gradients across the surface area of the package. Thermal shock to the package (>30°C per second) must be minimized.

### Ripple Rejection

Ripple Rejection curves were generated using an adjustable output TCL1117 with a bypass capacitor from ADJ to ground. To obtain the performance shown in the curves, the impedance of the bypass capacitor (at the ripple frequency) should be less than R1. R1 is typically 100Ω to 200Ω. For example at 120Hz, with R1 = 100Ω, the adjust capacitor should be at least 13μF. Only 0.16μF would be required at 10kHz.

The output ripple increases as the ratio of the output voltage to the reference voltage ( $V_{OUT}/V_{REF}$ ) in fixed voltage devices, and adjustable devices without an adjust pin capacitor. For example, at 5V, output ripple will increase by a factor of 4 (5/1.25V). Ripple rejection will be reduced by 12db from the value shown on the curve.

TYPICAL APPLICATIONS

1.2V-10V Adjustable Regulator

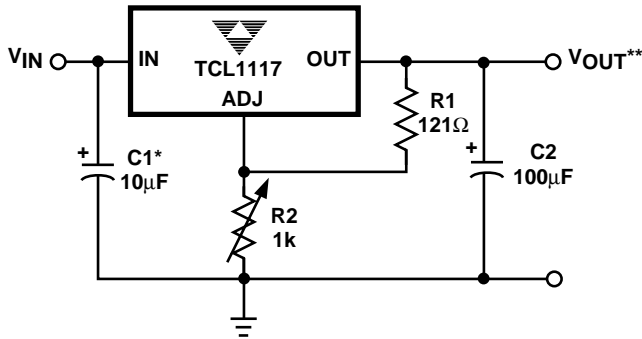

5V Regulator with Shutdown

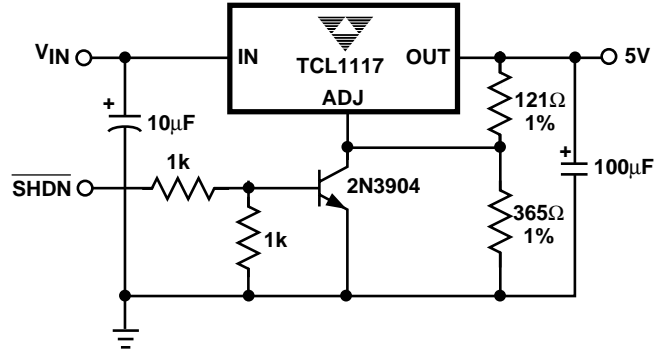

\* NEEDED IF DEVICE IS FAR FROM FILTER CAPACITORS

$$** V_{OUT} = 1.25V \left(1 + \frac{R2}{R1}\right)$$

Remote Sensing

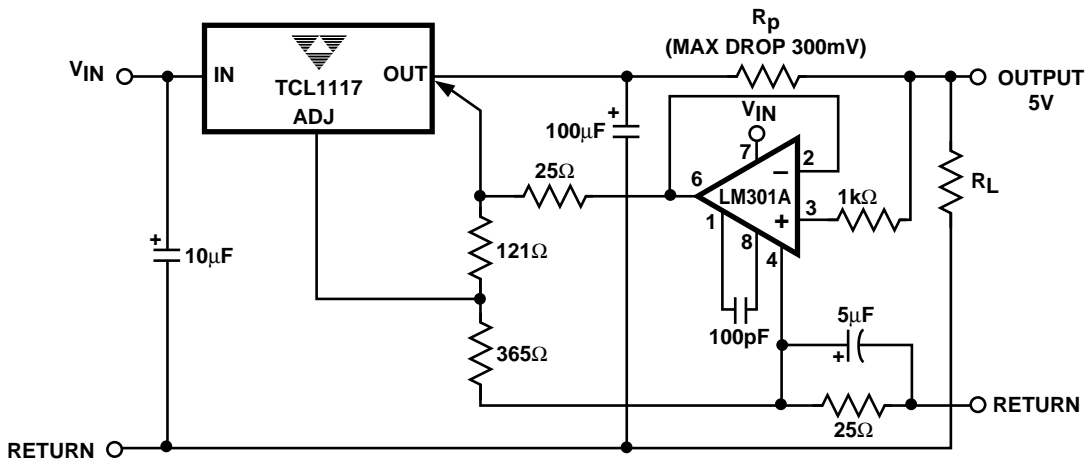

Adjusting Output Voltage of Fixed Regulators

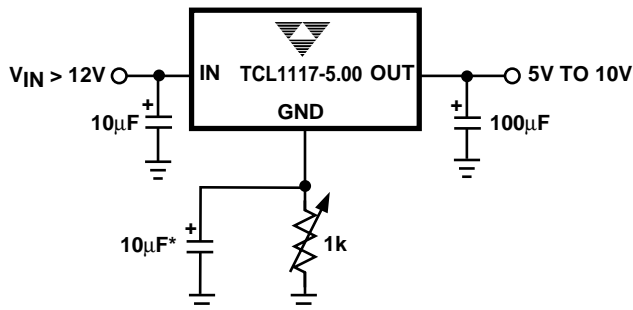

\*OPTIONAL IMPROVES RIPPLE REJECTION

Battery Charger

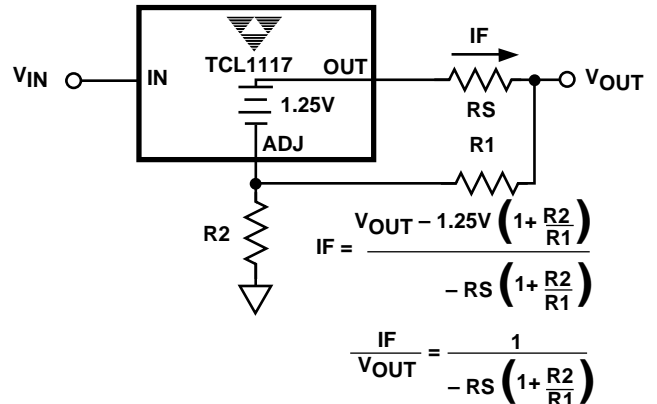

TCL1117  
TCL1117-2.85  
TCL1117-3.30  
TCL1117-5.00

TYPICAL APPLICATIONS (Cont.)

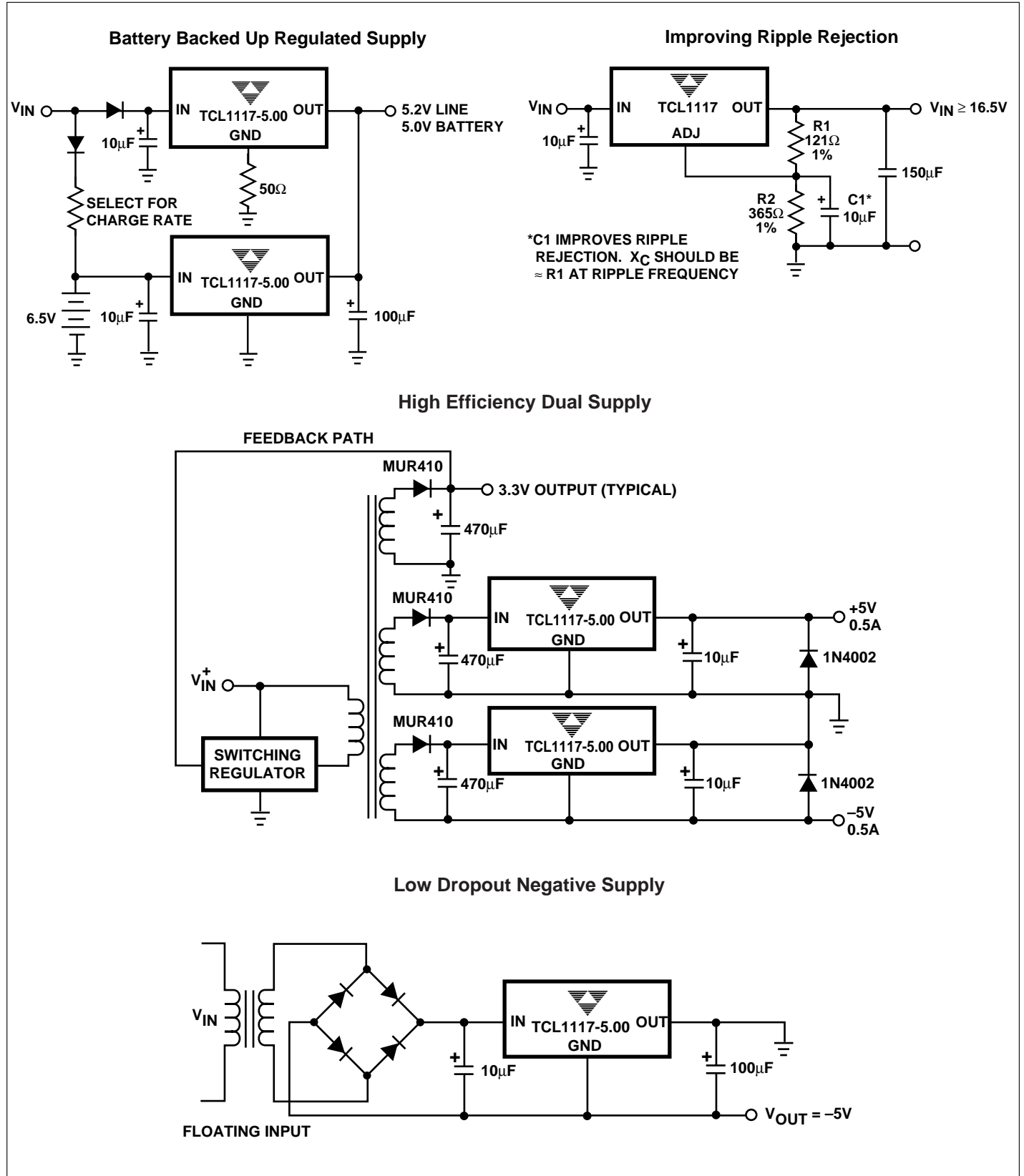

TYPICAL CHARACTERISTICS

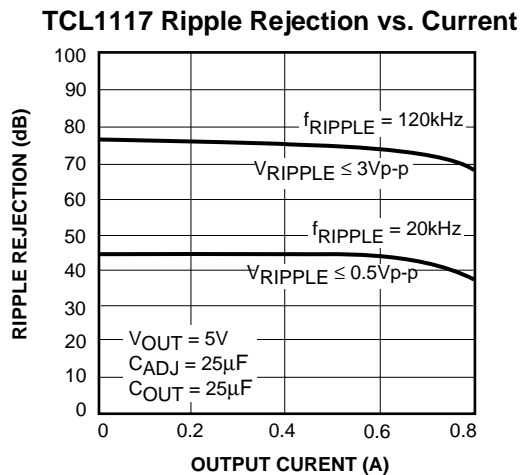
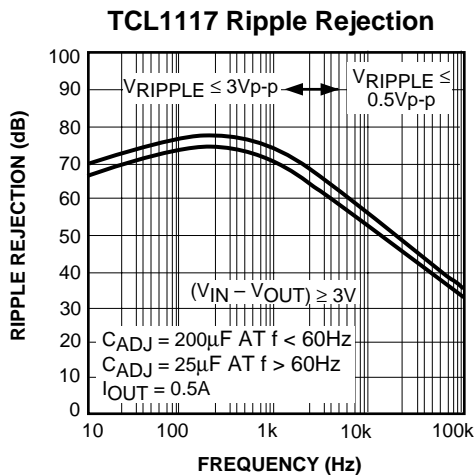
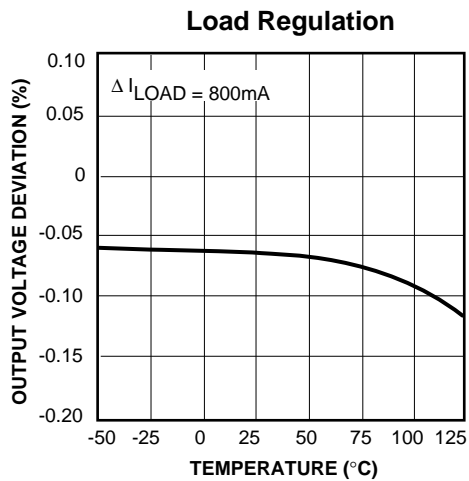
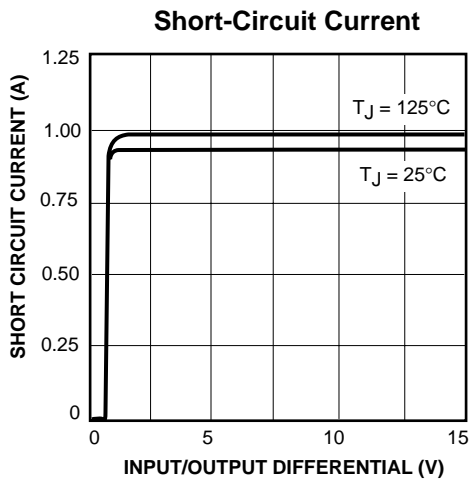
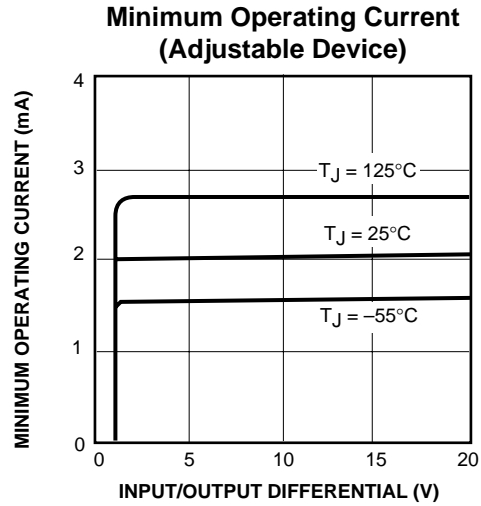
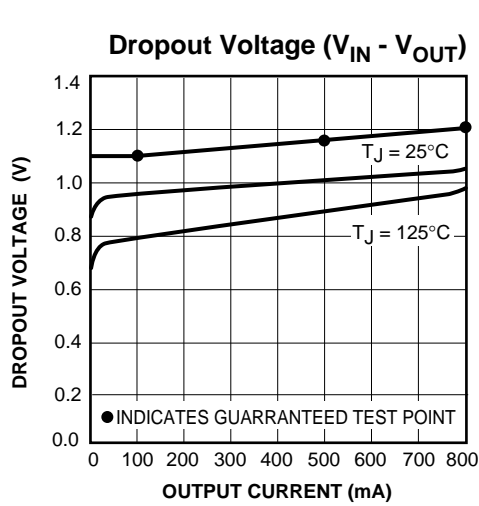

TCL1117  
TCL1117-2.85  
TCL1117-3.30  
TCL1117-5.00

TYPICAL CHARACTERISTICS (Cont.)

Temperature Stability

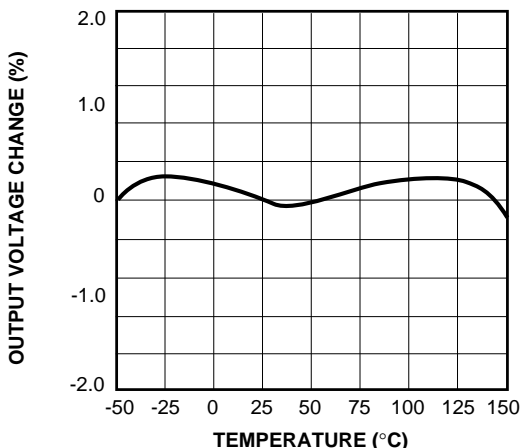

Adjust Pin Current

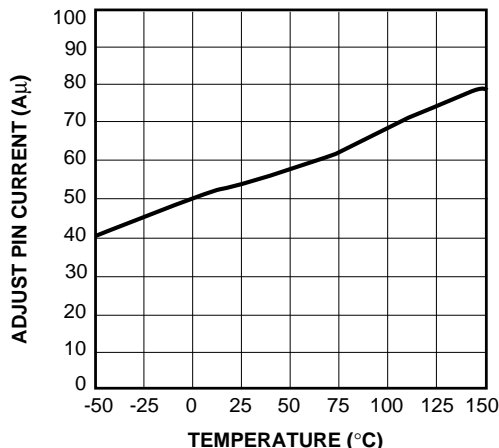

TCL1117-2.85 Load Transient Response

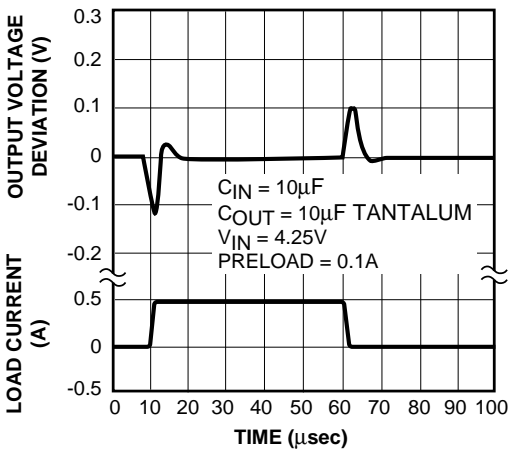

TCL1117-5 Load Transient Response

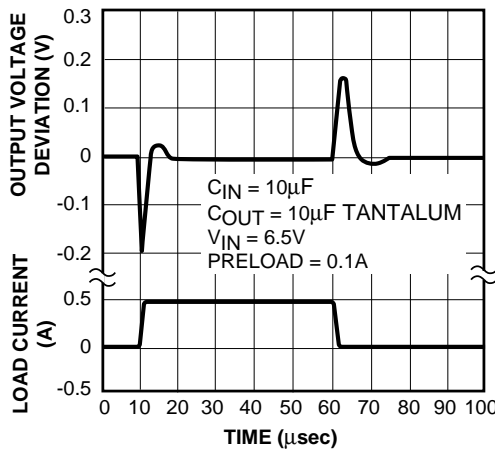

TCL1117-2.85 Line Transient Response

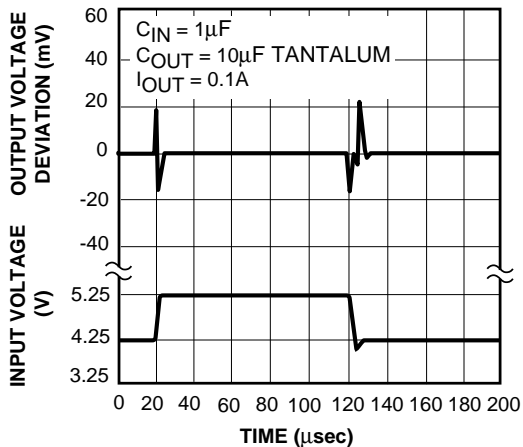

TCL1117-5 Line Transient Response

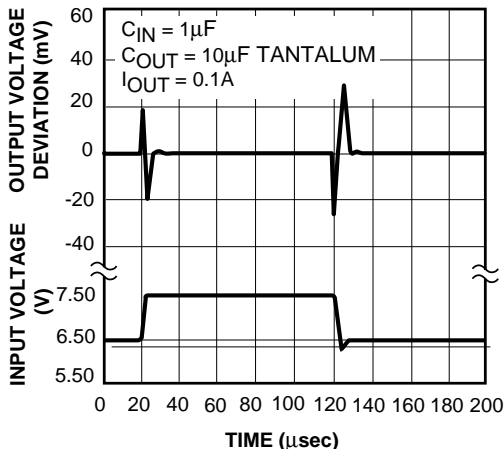



**800mA LOW DROPOUT POSITIVE REGULATORS  
ADJUSTABLE AND FIXED 2.85V, 3.30V, 5.00V**

PRELIMINARY INFORMATION

**TCL1117  
TCL1117-2.85  
TCL1117-3.30  
TCL1117-5.00**

**PACKAGE DIMENSIONS**

**SOT-223**

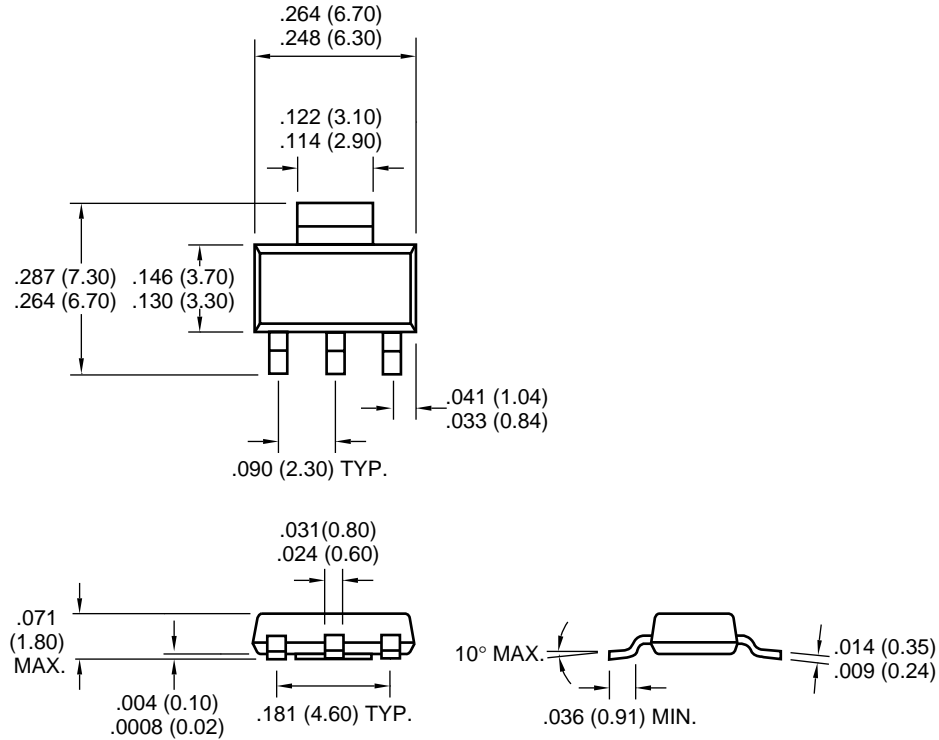

**DDPAK-3**

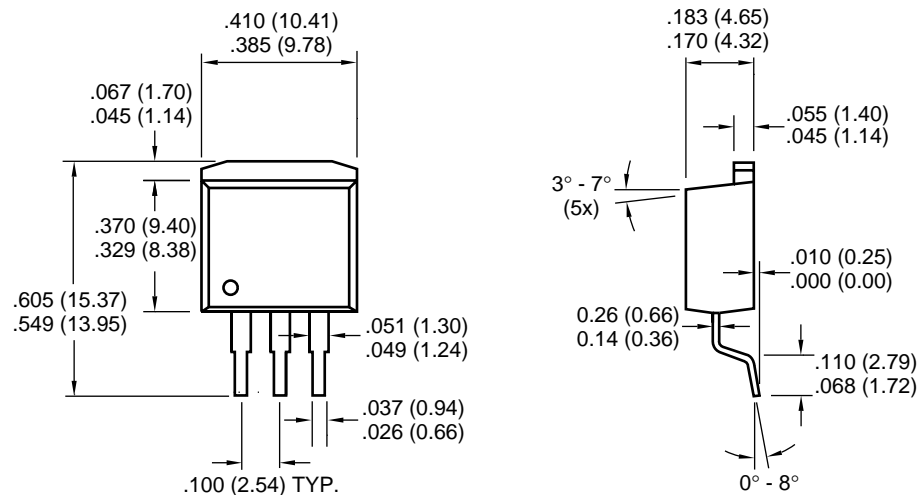

Dimensions: inches (mm)

**Sales Offices**

**TelCom Semiconductor**  
1300 Terra Bella Avenue  
P.O. Box 7267  
Mountain View, CA 94039-7267  
TEL: 415-968-9241  
FAX: 415-967-1590  
E-Mail: liter@c2smtp.telcom-semi.com

**TelCom Semiconductor**  
Austin Product Center  
9101 Burnet Rd. Suite 214  
Austin, TX 78758  
TEL: 512-873-7100  
FAX: 512-873-8236

**TelCom Semiconductor H.K. Ltd.**  
10 Sam Chuk Street, Ground Floor  
San Po Kong, Kowloon  
Hong Kong  
TEL: 852-2324-0122  
FAX: 852-2354-9957