

SYSTEM AND INTERNAL BLOCK DIAGRAM

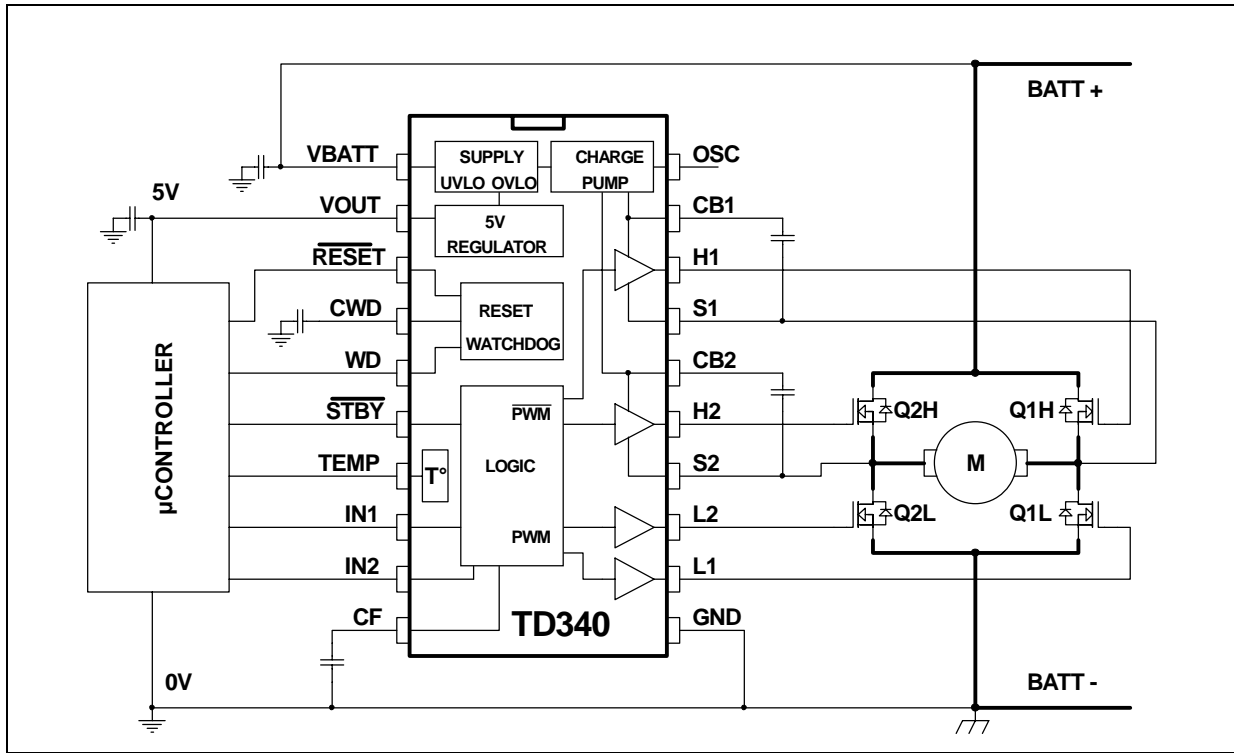

PIN DESCRIPTION

Name	Pin	Type	Function
VBATT	1	Power Input	Power Supply
GND	11	Ground	Ground
L1	12	Push Pull Output	Low Side Drive - Gate 1
L2	13	Push Pull Output	Low Side Drive - Gate 2
H1	18	Push Pull Output	High Side Drive - Gate 1
H2	15	Push Pull Output	High Side Drive - Gate 2
S1	17	Analog Input	High Side Drive - Source 1
S2	17	Analog Input	High Side Drive - Source 2
CB1	19	Analog Input	High Side Drive - Bootstrap Capacitor 1
CB2	16	Analog Input	High Side Drive - Bootstrap Capacitor 2
CF	10	Analog Input	External Capacitor to set the PWM Switching Frequency
IN1	8	Analog or Digital Input	Analog Level of PWM (0 to 100%) if CF connected to a capacitor, or PWM Signal if CF connected to ground
IN2	9	Digital Input	Direction to the Motor's Rotation
STBY	6	Digital Input	Standby Mode
TEMP	7	Analog Output	Analog Indicator of Temperature
VOUT	2	Power Output	Regulated Power Supply Output for the Microcontroller - 5V
RESET	3	Open Drain Output	Reset Signal for the Microcontroller
WD	5	Digital Input	Watchdog Signal from the Microcontroller
CWD	4	Analog Input	External Capacitor to set Watchdog Timeout
OSC	20	Digital Output	Oscillator Output

ABSOLUTE MAXIMUM RATINGS

Symbol	Parameter	Value	Unit
V_{Batt}	Positive Supply Voltage - Note 1	60	V
P_d	Power Dissipation	500	mW
T_{stg}	Storage Temperature	-55 to +150	°C
ESD	Electrostatic Discharge	2	kV
$V_{digital}$	Voltage on pins: IN1, IN2, STBY, WD, CWD, CF, TEMP, VOUT, RESET	-0.3 to 7	V
$V_{lowgate}$	Voltage on pins: L1, L2	-0.3 to 15	V
V_{power}	Voltage on pins: H1, H2, S1, S2, CB1, CB2 - Note 2	-0.3 to 60	V
V_{osc}	Voltage on pin OSC	Vbatt-6.5 to Vbatt	V
T_j	Maximum Junction Temperature	150	°C
R_{hja}	Thermal Resistance Junction-Ambient	85	°C/W

Notes:

1. The duration of the 60V voltage must be limited to 1 second if current is drained from the Vout regulator. Supply voltage in steady state must be limited to ensure that dissipation rating is not exceeded.
2. The magnitude of input and output voltages must never exceed Vbatt+0.3V or 60V, whichever is less, except for H1 and H2: Vbatt+15V or 60V, whichever is less.

OPERATING CONDITIONS

Symbol	Parameter	Value	Unit
V_{batt}	Positive Supply Voltage	6.5 to 18.5	V
T_{oper}	Operating Free Air Temperature Range	-40 to +125	°C

ELECTRICAL CHARACTERISTICSV_{batt}= 12V, T_{amb}=-40°C to 125°C (unless otherwise specified)

Symbol	Parameter	Test Condition	Min.	Typ.	Max.	Unit
I _{CC}	Total Supply Current	T=25°C -40°C < T < 125°C		4.5 5	7 10	mA mA
I _{stdby}	Supply Current in Standby Mode	T=25°C -40°C < T < 125°C		340	500 550	μA μA
Standby _H	STDBY Pin Voltage for Standby OFF		0.8			V
Standby _L	STDBY Pin Voltage for Standby ON				2	V
UVLO	Under Voltage Lockout - when V _{batt} <UVLO all buffer outputs are low	V _{batt} decreasing Hyst. = 100mV typ.	5.8	6.2	6.5	V
OVLO	Under Voltage Lockout - when V _{batt} >OVLO all buffer outputs are low	V _{batt} decreasing Hyst. = 300mV	18.5	20	21.5	V
DRIVERS - Cbootstrap=47nF						
V _{gs}	Static Gate-Source High Side Mosfet Voltage (charge pump)	No Bootstrap Cap	8	11	15	V
V _{gsd}	Dynamic Gate-Source High Side Mosfet Voltage (bootstrap)			9		V
Freq	Switching Frequency of PWM	Cf = 270pF	20	25	30	kHz
t _d	Dead Time for secure Synchronous Rectification	Cf=270pF, IN1=2.4V No Load Cload=4nF	2.1	2.8 1.5	3.5	μs μs
I _{outl}	Output Current Capability - Low Side Source	T=25°C -40°C < T < 125°C	30 25	50 50	100 100	mA mA
	Sink	T=25°C -40°C < T < 125°C	60 50	100 100	150 150	mA mA
I _{outh}	Output Current Capability - High Side Source	T=25°C -40°C < T < 125°C	30 25	50 50	100 100	mA mA
	Sink	T=25°C -40°C < T < 125°C	60 50	100 100	150 150	mA mA
OSCILLATOR - Rosc=5.6k - Note 1						
F _{osc}	Frequency of internal Step up converter Oscillator	T=25°C -40°C < T < 125°C	0.6 0.5	1 1	1.4 1.5	MHz MHz
V _{osc}	Oscillator Swing	V _{batt} = 12V V _{batt} = 9V V _{batt} > UVLO	6.25 6.25 5.1		12 12 12.5	V V V

ELECTRICAL CHARACTERISTICS (continued)V_{batt}= 12V, T_{amb}=-40°C to 125°C (unless otherwise specified)

Symbol	Parameter	Test Condition	Min.	Typ.	Max.	Unit
VOLTAGE REGULATOR - Co=220nF - note 2						
V _{out}	Output Voltage	I _o =20mA T=25°C -40°C < T < 125°C	4.6 4.5	5 5	5.4 5.5	V V
Line Reg	Line Regulation	6V < V _{batt} < 16V, I _o =20mA T=25°C -40°C < T < 125°C			85 130	mV mV
Load Reg	Load Regulation	0 ≤ I _o ≤ 20mA T=25°C -40°C < T < 125°C			40 60	mV mV
I _o	Maximum Output Current	V _{batt} = 12V, T=25°C 6V < V _{batt} < 16V, -40°C < T < 125°C	20	40		mA mA
I _{os}	Output Current Short Circuit	V _{out} =0		100	200	mA
RESET SUPERVISORY CIRCUIT - note 3						
V _{thi}	Threshold Voltage V _{out} Increasing	T=25°C -40°C < T < 125°C	4.0 3.9	4.3	4.5 4.6	V V
V _{thd}	Threshold Voltage V _{out} Decreasing	T=25°C -40°C < T < 125°C	3.9 3.8	4.2	4.4 4.5	V V
k _i	Linearity coefficient (V _{thi} = k _i V _{out})			0.86		
k _d	Linearity coefficient (V _{thd} = k _d V _{out})			0.84		
V _{hys}	Hysteresis Threshold Voltage		50	100	200	mV
t _{phl}	Response Time High to Low			5		μs
WATCHDOG CIRCUIT						
t _{wd}	Watchdog Time Out Period	No ext. capacitor C _{wd} = 47nF - note 4	0.5 0.7	1 1	2 1.5	ms s
t _{ipw}	Watchdog Input Pulse Width for Proper Retrigger		0.1			μs
t _{ipr}	Watchdog Input Rise Time for Proper Retrigger				0.1	μs
t _{reset}	Reset Pulse Width		10	20	40	μs
TEMPERATURE OUTPUT						
V _T	Output Voltage	T= 25°C	2.58	2.68	2.78	V
ΔV _T	Output Temperature Drift		-7	-7.5	-7.8	mV/°C

Notes :

- For proper operation, a 5.6k resistor needs to be connected between OSC and GND.
- 220nF is the optimized value for the voltage regulator
- The reset thresholds (V_{out} increasing and decreasing) are proportional to V_{out}, (coefficients k_i and k_d). k_i and k_d vary in the same direction with temperature.
- Watchdog capacitor C_{wd} should be placed as close as possible to CWD pin.

INTERNAL ELECTRICAL SCHEMATIC AND APPLICATION ENVIRONMENT

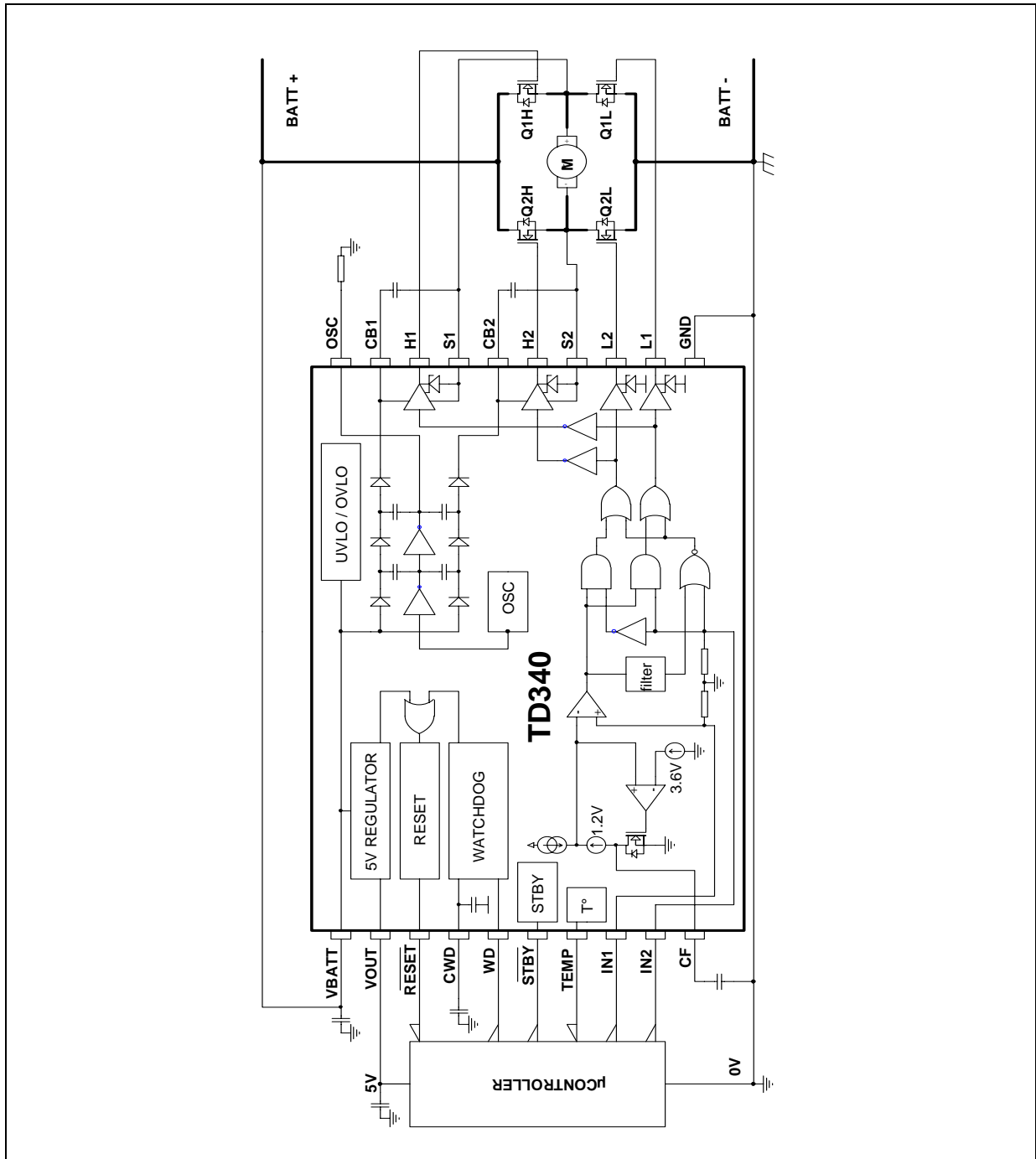

FUNCTIONAL DESCRIPTION

Speed and Direction Control:

The TD340 IC provides the necessary interface between an H-Bridge DC-Motor Control configuration and a micro controller. The speed and direction are given by two input signals coming from the microprocessor.

Speed Control:

Speed control is achieved by Pulse Width Modulation (PWM).

The TD340 provides an internal PWM generator, but can accept an external PWM waveform.

IN1 can accept two different types of inputs:

- an analog input between 0 and 5V (CF must be connected to set the PWM frequency) gives an analog value of the Internal PWM duty cycle
- a digital input (CF must be grounded) gives directly the PWM

Figure 1 represents the Duty Cycle curve versus the IN1 analog voltage.

Figure 2 shows how to use the TD340 with an analog input or a digital input.

The speed control (or duty cycle) is achieved by the Low Side Drivers which impose the PWM function while the cross-corresponding High Side MOSFETS is kept fully ON.

Direction Control:

IN2 accepts a digital value of the rotation direction.

Brake mode:

Brake mode is achieved by a zero level on the IN1 input.

The IN2 input selects low side or high side braking.

Brake mode is activated when the IN1 is at zero volt level for more than 200 us.

Figure 1 : Duty Cycle versus IN1 voltage

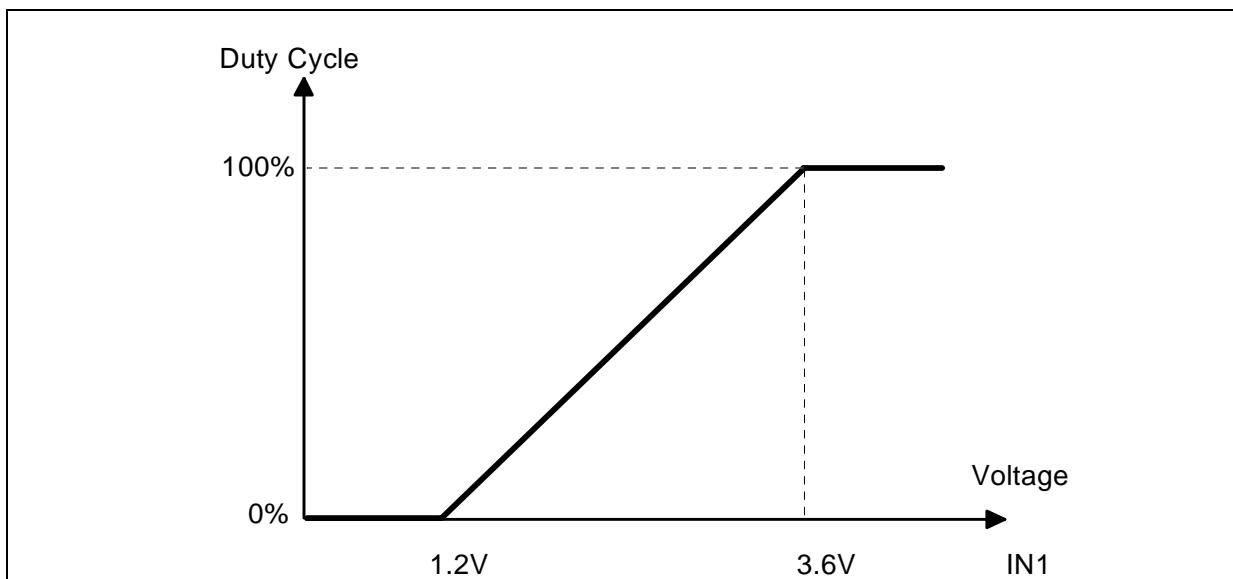
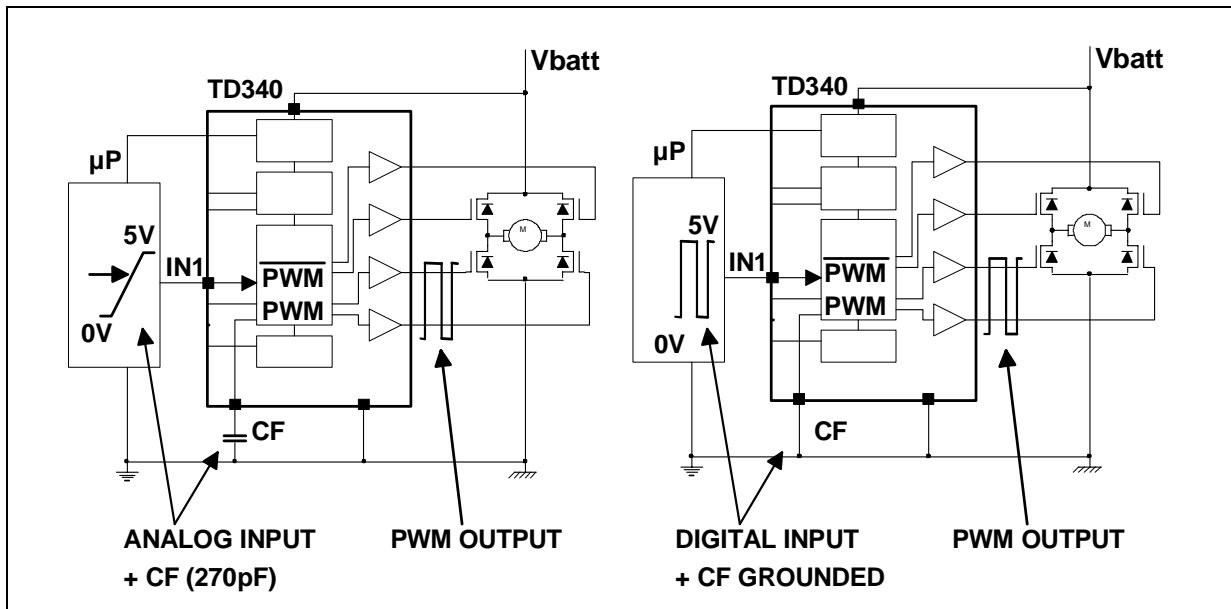

Figure 2 : PWM Analog and Digital Modes



Active (synchronous) rectification for free-wheel current

A motor is an inductive load. When driven in PWM mode, motor current is switched on and off at the 25kHz frequency. When the MOS is switched off, current can not instantaneously drop to zero, a so-called "free-wheel" current arises in the same direction than the power current. A path for this current must be provided, otherwise high voltage could arise and destroy the component. The classical way to handle this situation is to connect a diode in an anti-parallel configuration regarding to the MOS, so that current can continue to flow through this diode, and finally vanishes by the means of ohmic dissipation, mainly in the diode due to its 0.8V direct voltage. For high currents, dissipation can be an important issue (eg: 10A x 0.8V makes 8 W!). Furthermore, high speed diodes have to be used, and are expensive.

A more efficient way to handle this problem is to use the high side MOS as a synchronous rectifier. In this mode, the upper MOS is switched ON when the lower one is switched OFF, and carries the free-wheel current with much lower ohmic dissipation. Advantages are : one expensive component less (the fast power diode), and more reliability due to the lower dissipation level.

However, we have to take care not to drive the two MOS simultaneously. To avoid transient problems when the MOS are switched, a deadtime is inserted between the opening of one MOS, and the closing of the other one. In the TD340 device, the deadtime is fixed to about 2.5 microseconds. This value is the time between the commands of the gate drivers, not the deadtime between the actual MOS states because of the rising and falling times of the gate voltages (due to capacitance), and the MOS characteristics. The actual value of the deadtime for a typical configuration is about 1.5 microseconds.

Figure 3 shows the synchronous rectification principle

Table 1 summarizes the status of the Mosfets (and the speed and direction of the motor) according to the Inputs (IN1 and IN2) status in analog and logic modes.

Figure 3 : Synchronous Rectification Principle

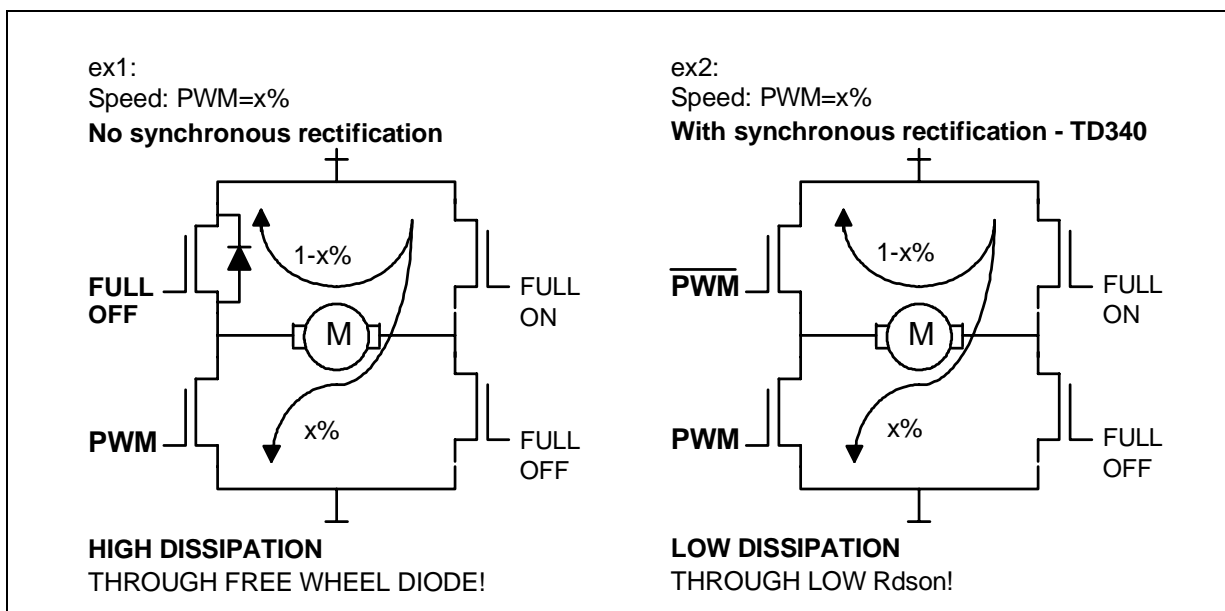

Table 1 : Function Table in Digital and Analog Modes

Stby State	Disable State	IN1 (V)		IN2 (V)	Mosfets Status				Comments
		digital	analog		Q1L	Q1H	Q2L	Q2H	
1	X	X	X	X	OFF	OFF	OFF	OFF	Motor Off in Standby Mode
X	1	X	X	X	OFF	OFF	OFF	OFF	Motor Off in Disable Mode
0	0	0 idle	0 to 1.2	0	ON	OFF	ON	OFF	Motor Brake Low
0	0	0 idle	0 to 1.2	5	OFF	ON	OFF	ON	Motor Brake High
0	0	PWM	1.2 to 3.6	0	OFF	ON	PWM	!PWM	Motor x% Forward
0	0	PWM	1.2 to 3.6	5	PWM	!PWM	OFF	ON	Motor x% Backward
0	0	5 idle	3.6 to 5	0	OFF	ON	ON	OFF	Motor 100% Forward
0	0	5 idle	3.6 to 5	5	ON	OFF	OFF	ON	Motor 100% Backward

Notes:

- Standby state is active when STBY pin is pulled low
- Disable state is active when one of the following conditions is met: UVLO, OVLO, Reset, Watchdog Timeout.

MOS drivers

Output drivers are designed to drive MOS with gate capacitance of up to 4 nF. A small resistor in serial with gate input is recommended to prevent spurious oscillations due to parasitic inductance in conjunction with gate capacitance. Typical value of these resistors are from 10 to 100 ohms, depending on the MOS characteristics.

Charge pump

To drive the high side MOS, the TD340 has to provide a voltage of about 10V higher than the power supply voltage. The TD340 provides an internal charge pump which acts as a voltage tripling generator clamped to 12V and allows the output of correct gate voltage with power voltage level as low as 6.5V. Its double balanced structure ensures low EMI Ground Noise. The internal charge pump is used to achieve correct voltage level at startup or static states.

An 5.6k resistor needs to be connected between OSC and GND for proper operation.

Bootstrap capacitors

To achieve dynamic driving up to 25kHz, it is necessary to support the internal charge pump with bootstrap capacitors.

Bootstrap capacitors are charged from Vbat when the lower MOS is ON. When the lower MOS is switched off and the upper one is switched ON, the bootstrap capacitor provides the necessary current to the driver in order to charge the gate capacitor to the right voltage level.

A design rule to select the bootstrap capacitor value is to choose ten times the gate capacitance.

For example, MOS with 4 nF gate capacitance will require bootstrap capacitors of about 47nF.

MOS gate discharge

The high side MOS are switched off with internal Gate to Source discharge (not Gate to Ground discharge) to prevent the Gates from negative transient voltages.

Figure 4 : Typical waveforms on low and high side MOS gates.

Upper trace : High side MOS gate

Lower trace : Low side MOS gate

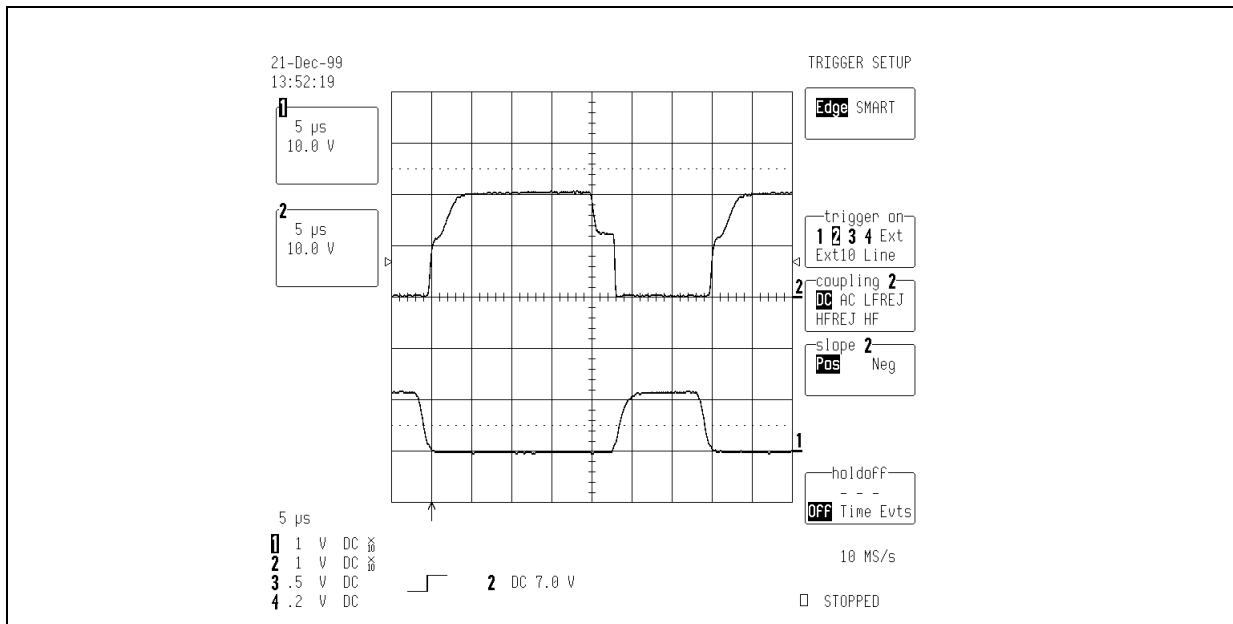

Reversed battery active protection

In full H-bridge configuration, there is a risk in case of power voltage reversal due to the intrinsic diodes inside the MOS. A passive protection solution is to wire a diode between the H-bridge and the power supply. Disadvantages are voltage drop and power dissipation.

The TD340 provides support for reversed battery active protection.

An oscillator OSC output is available to allow proper command of a 5th MOS connected upside down.

The MOS must have low threshold voltage because the oscillator output swing is about 6.5V.

In normal conditions, the MOS intrinsic diode supplies power to the driver at startup. When the TD340 is started, the OSC output enables the MOS to switch on, providing lower voltage drop and lower power dissipation.

In case of reversed battery, the 5th MOS remains off, and no dangerous voltages can reach the driver nor the power MOS.

The OSC oscillator can only supply a few mA. It must be loaded with a large impedance, typically 100pF and 680k.

Figure 5 : Reversed Battery Active Protection Principle

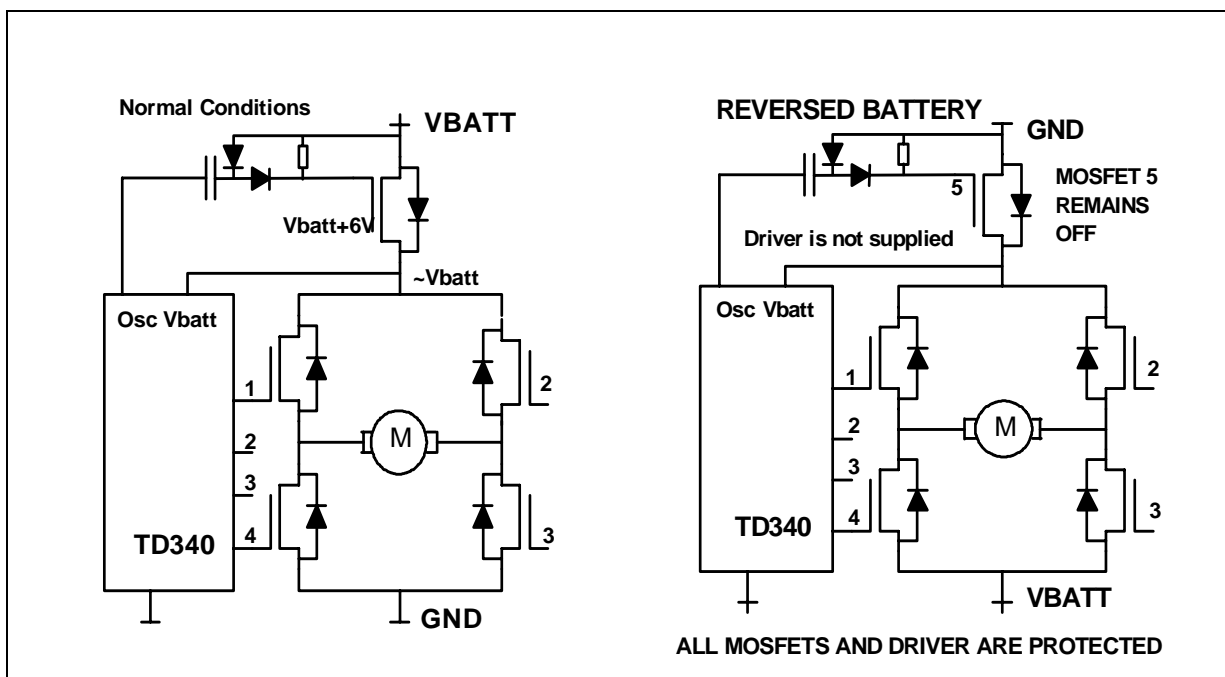

UVLO and OVLO protections

The TD340 includes protections against overvoltage and undervoltage conditions.

Overvoltage is dangerous for the MOS and for the load due to possible excessive currents and power dissipation.

Undervoltage is dangerous because MOS driving is no more reliable. MOS could be in linear mode with high ohmic dissipation.

TD340 Under Voltage LockOut and Over Voltage LockOut features protect the system from non-operational power voltage. UVLO and OVLO thresholds are 6.2V and 20V. Hysteresis provides reliable behavior near the thresholds.

During UVLO and OVLO, MOS are switched off (TD340 in disable state).

Microcontroller support

For easy system integration, the TD340 provides the following functions:

- 5V regulator,
- reset circuit,
- watchdog circuit,
- standby mode,
- temperature indicator.

5V regulator

The TD340 provides a 5V regulated voltage at VOUT pin with a maximum current of 20mA over the whole Vbatt range (6.5 to 16V). Current can be up to 40 mA with nominal 12V Vbatt.

It is mandatory to connect a 220nF capacitor to the 5V output, even if the 5V output is not used, because the 5V is internally used by the device. 220nF is the optimized value for the voltage regulator.

Reset circuit

The integrated supervisor circuit resets the micro controller as soon as the voltage of the Micro Controller decreases below 4.2V, and until the voltage of the micro controller has not passed above 4.3V.

RESET output is active low. It features an open drain with a internal 75k pull up resistor to internal 5V which allows hardwired OR configuration.

Figure 6 : Reset Waveforms

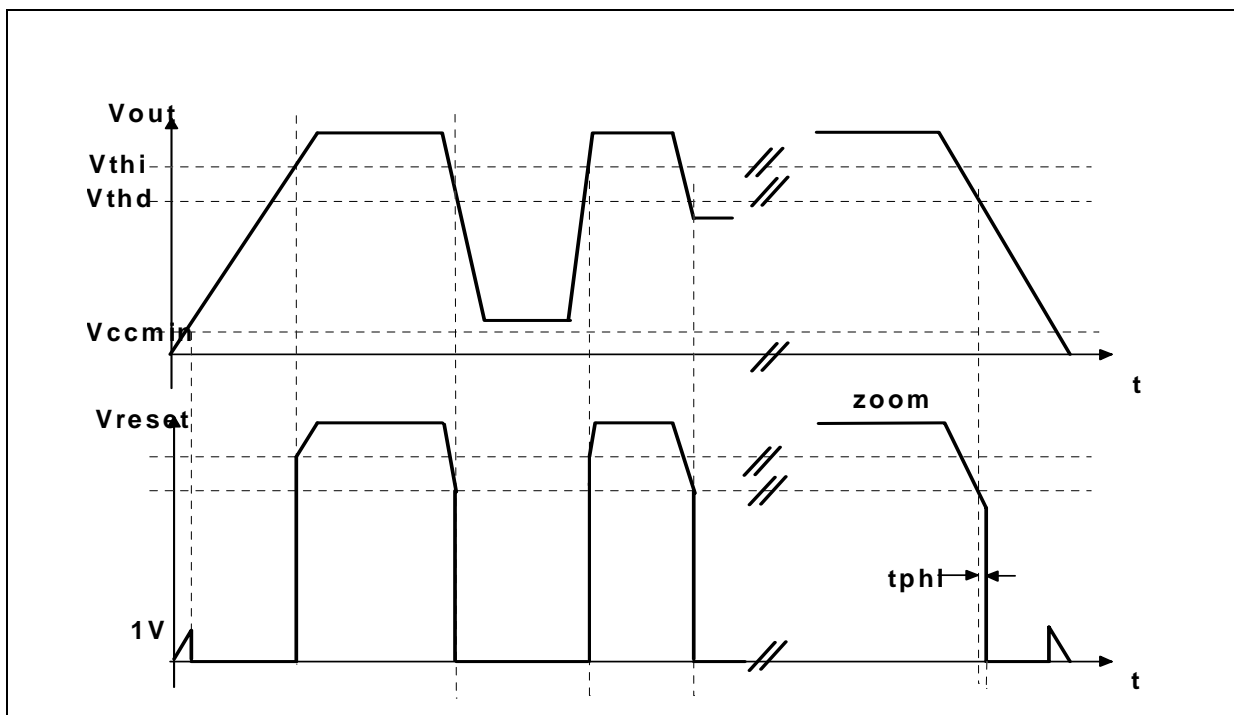

Watchdog circuit

An integrated Watchdog circuit resets the microcontroller when a periodic signal coming from the microcontroller is missing after an externally adjustable Time out delay.

Watchdog timeout is adjustable by means of a capacitor C_{wd} between CWD pin and GND. This capacitor should be placed as close as possible to the CWD pin.

Watchdog function can be inhibited by tying the CWD pin to ground.

Timeout range is from about 1ms to 1s, approximate value is given by:

$$T_{wd} = 1 + (20 \times C_{wd}) \quad (T_{wd} \text{ in ms, and } C_{wd} \text{ in nF}).$$

When the watchdog timeout triggers, the reset output is pulsed once low for 20 microseconds, and the driver outputs are set to ground (MOS switched off). TD340 stays in disable state (MOS off) until pulses appear again on WD pin.

Figure 7 : Watchdog waveforms

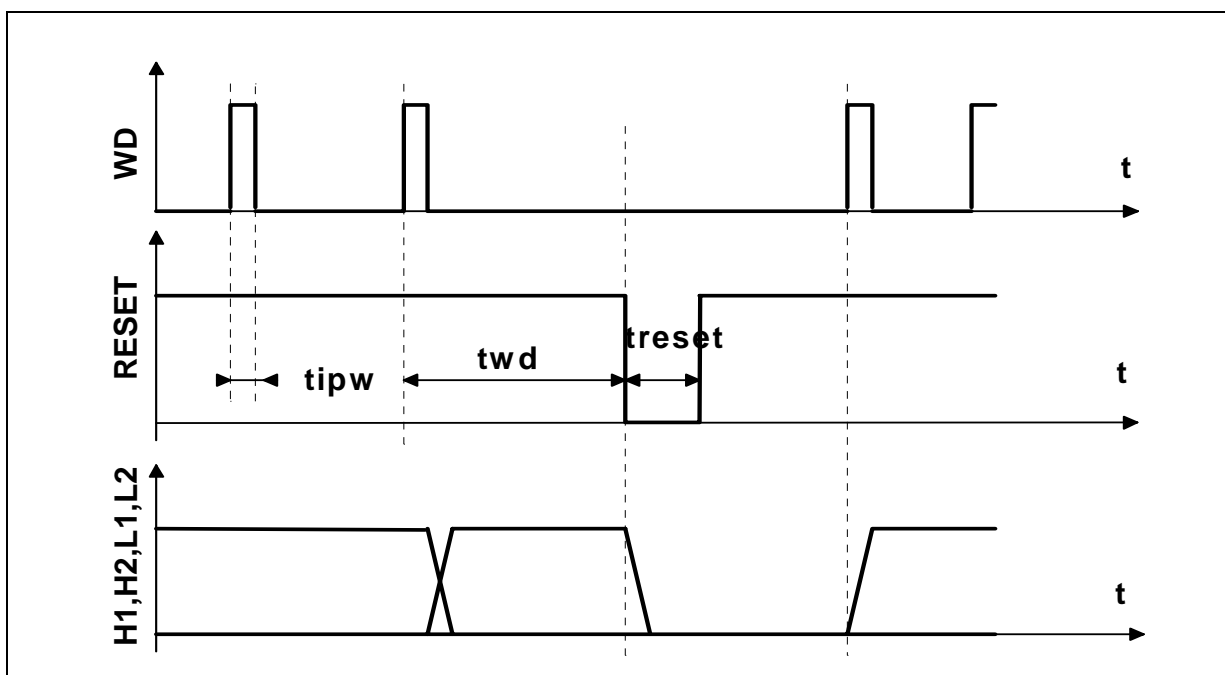

Temperature output

The TD340 provides a temperature indicator with the TEMP output.

TEMP voltage is 2.68V at 25°C with a temperature coefficient of -7.5mV/°C.

The goal of this function is to provide a rough temperature indication to the uP. It allows the system designer to adapt the behavior of the application to the ambient temperature.

The TEMP output must be connected to a high impedance input. Maximum available current is 1uA.

Standby mode

The TD340 can be put in standby mode under software control. When the STBY pin is driven low, the MOS drivers are switched off and internal charge pump oscillator is stopped. The 5V regulator, the watchdog and reset circuits are still active.
 There is no pull up/down resistor on the STBY pin. STBY must not be left open.

Power consumption (not including the current drained from the 5V regulator) is reduced to about 200uA. To achieve this standby current, the 5.6k resistor on the OSC pin has to be disconnected with an external low power MOS controlled by the STBY signal (see figure 10 for an application example)

Standby mode should be only activated when IN1=IN2=0V and after that the motor is actually stopped because the four MOS are switched off. On exit from the standby mode, a delay of up to 20ms (depending upon the bootstrap capacitor value) must be given before applying signals to the IN1 and IN2 inputs to allow proper startup of the charge pump (it is also true for power-up). Figure 8 shows the voltage across the Cb bootstrap capacitor at powerup or at standby exit as a function of time.

Figure 8 : Charge pump voltage at startup

Fig. 8a : Cb = 10nF

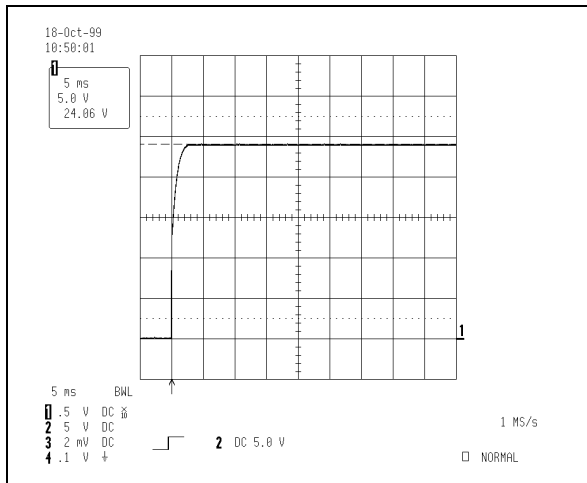

Fig. 8b : Cb = 47nF

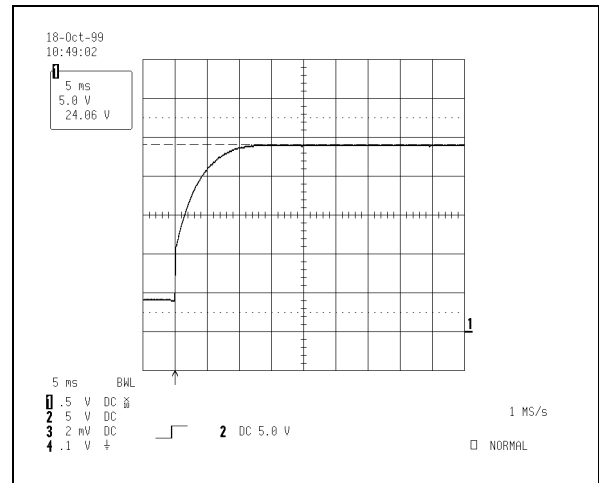
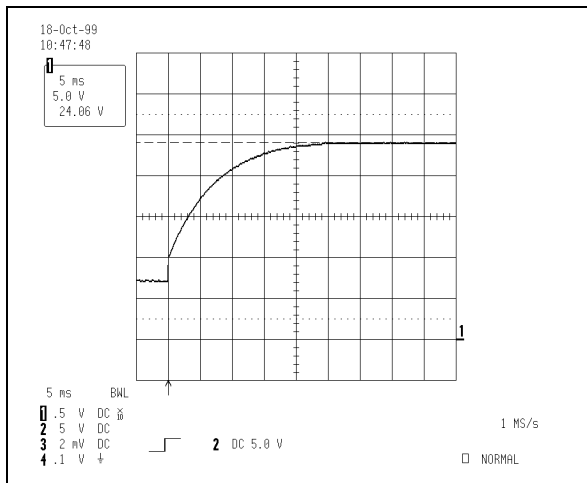
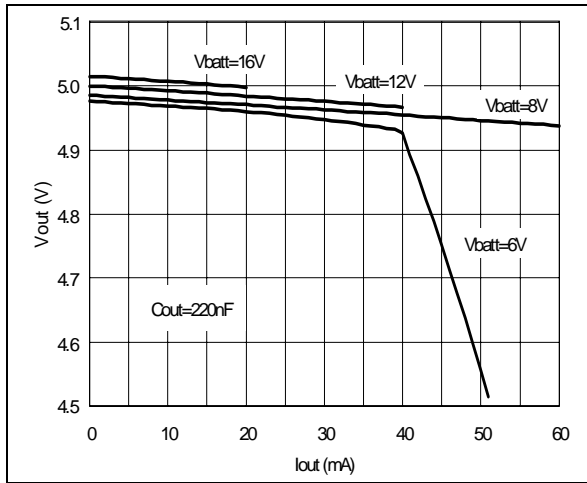

Fig. 8c : Cb = 100nF



PERFORMANCE CURVES

5V Regulator Voltage vs Output Current



5V Regulator Voltage vs Vbatt

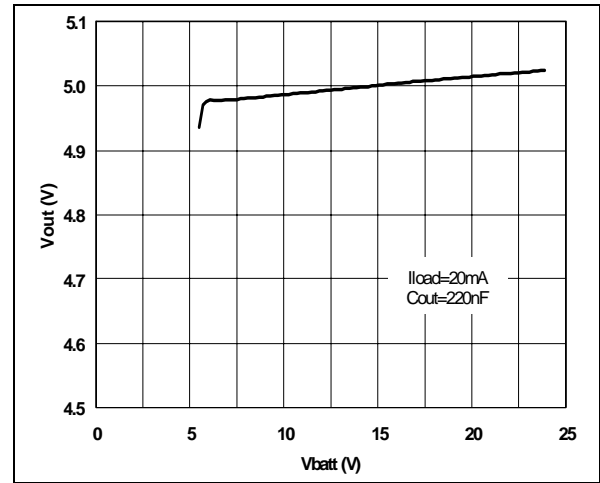

Charge Pump Voltage vs Current

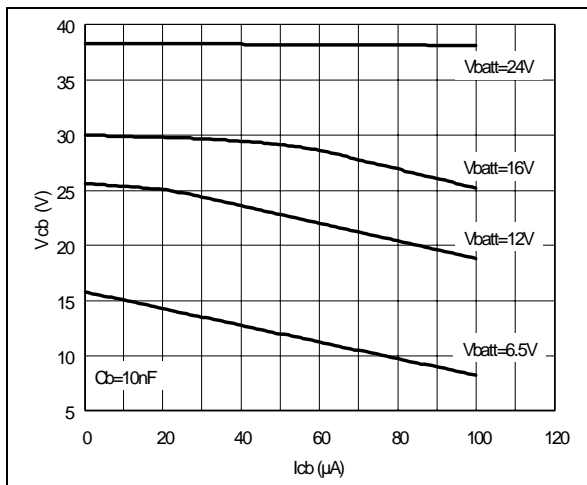

Charge Pump Voltage vs Vbatt

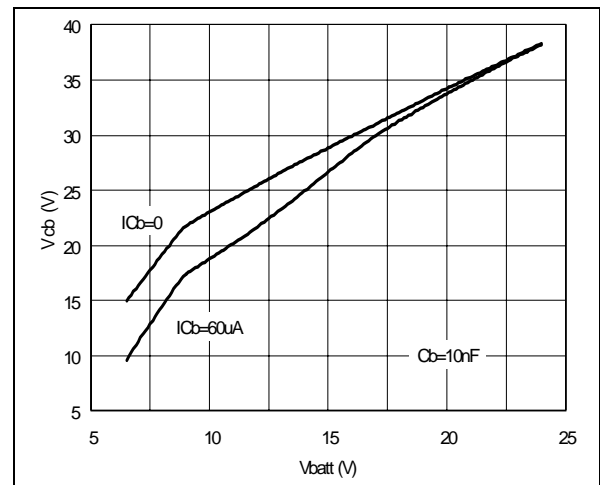

High Side MOS Static Vgs vs Vbatt

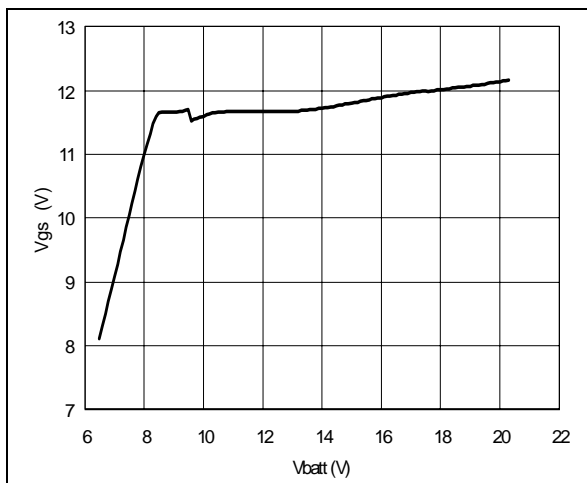

High Side MOS Static Vgs vs Temperature

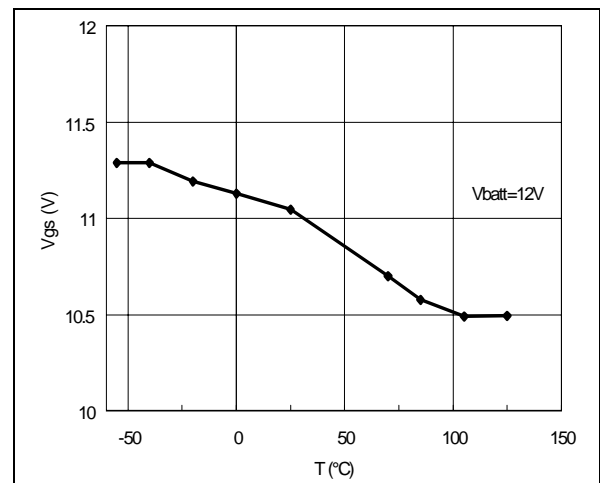

PERFORMANCE CURVES (continued) $V_{batt} = 12V$, unless otherwise specified

Supply current

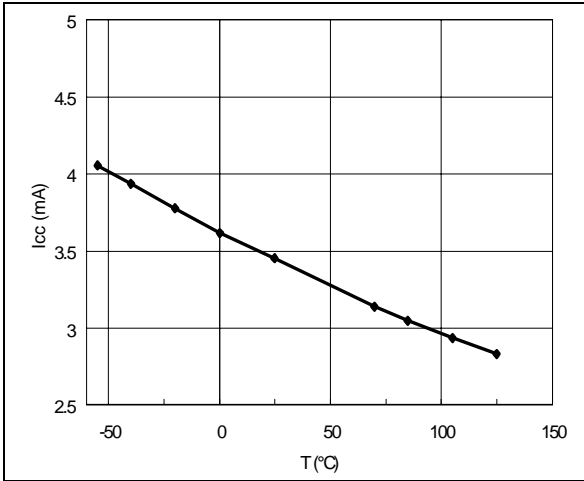

Standby current

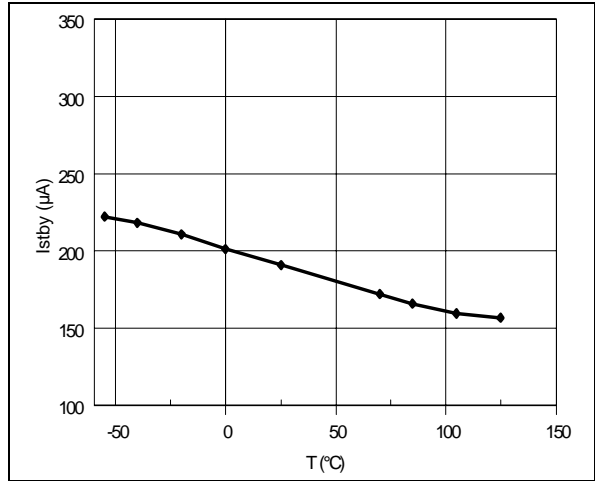

Reset Threshold (decreasing)

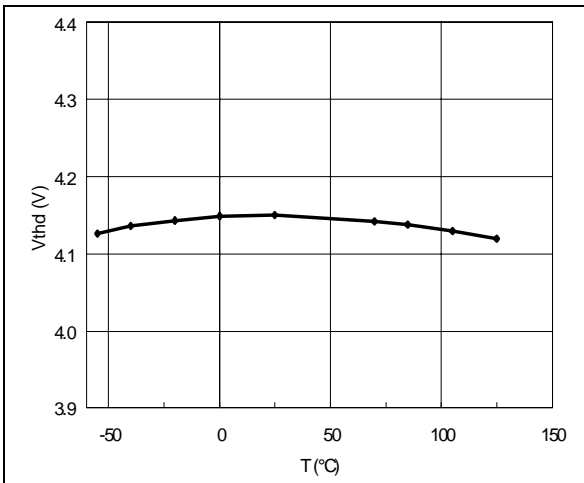

Reset Threshold (increasing)

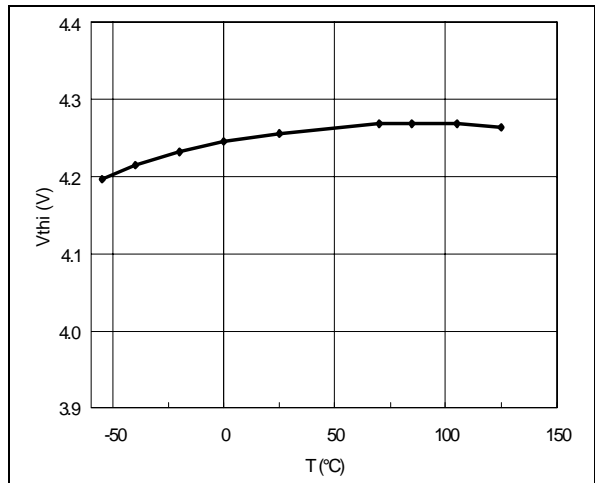

Under Voltage Lockout

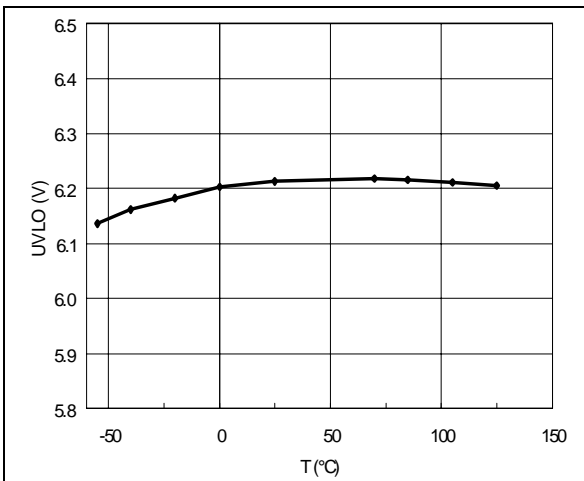

Over Voltage Lockout

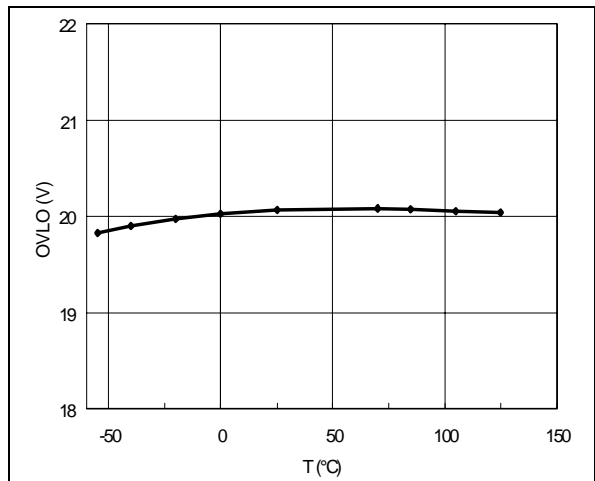

PERFORMANCE CURVES (continued) V_{batt}= 12V, unless otherwise specified

OSC Output Frequency

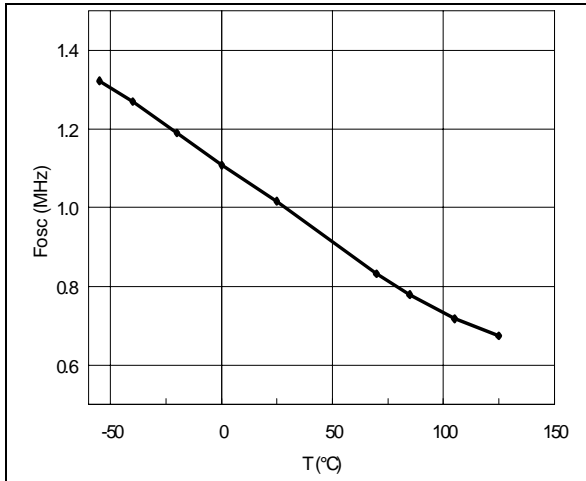

Deadtime between High and Low Drivers

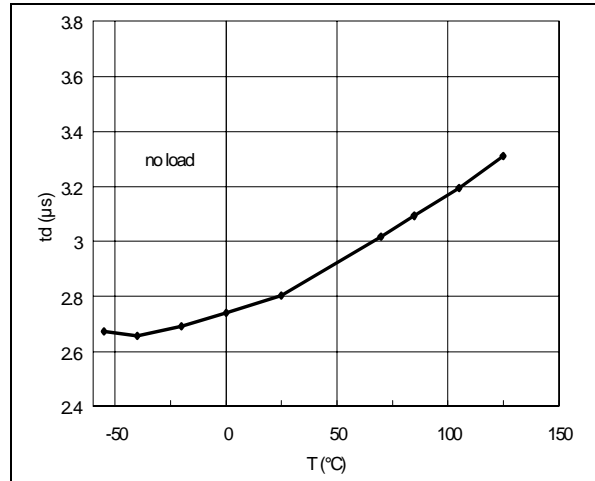

High Side Driver output Current (source)

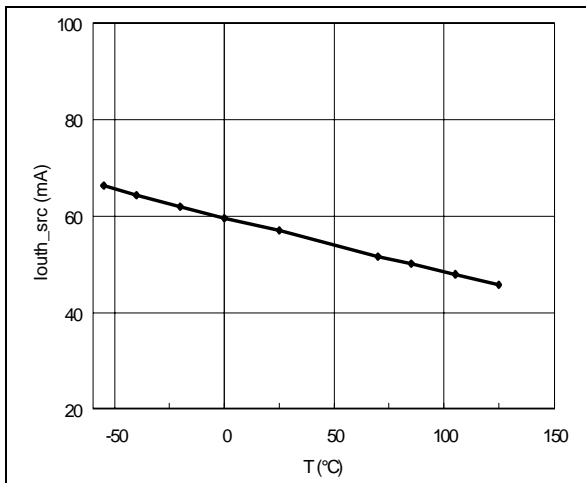

Low Side Driver output Current (source)

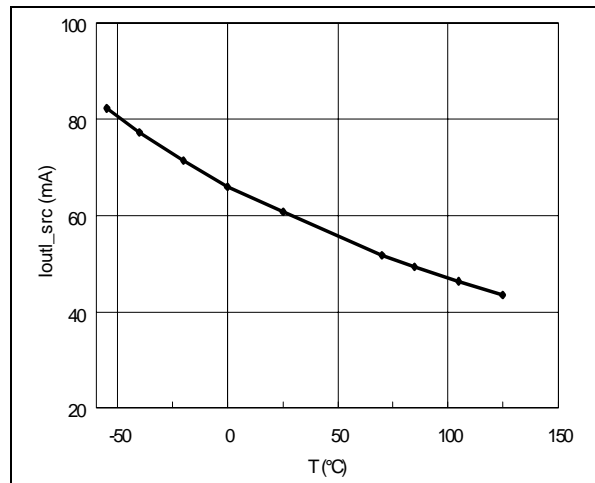

High Side Driver output Current (sink)

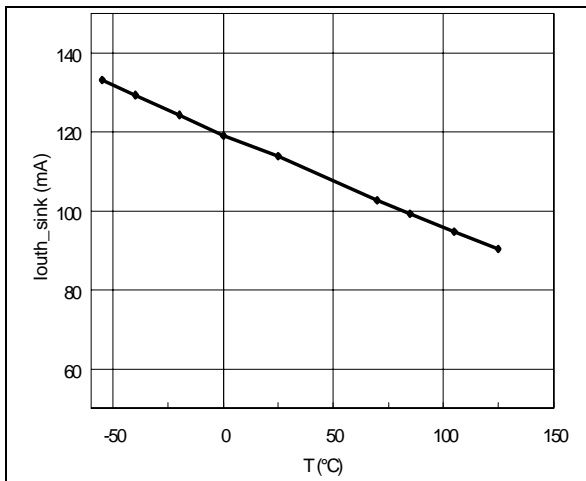

Low Side Driver output Current (sink)

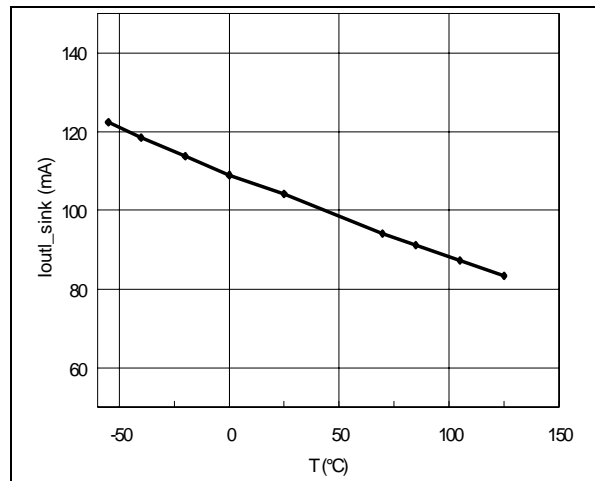

APPLICATION CIRCUIT DIAGRAMS

The following schematics show typical application circuits. The first one is a simple, standalone system, while the other one is μC driven and includes advanced features like standby mode and reversed battery active protection.

Simple standalone system

Figure 9 shows a basic use of the TD340. The speed is controlled with a simple adjustable resistor. Direction is controlled with a switch.

Internal PWM generator is used, frequency is set by the capacitor C3.

Note that the C2 capacitor (220nF) is included because it is needed by the internal TD340 circuit.

Interface lines for microcontroller are not used:

Standby is tied to 5V (Vout),

WD and CWD are tied to ground,

Reset and Temperature outputs are left unconnected.

Reversed battery protection is provided by the means of the diode D2.

Transistors Q1H, Q1L, Q2H, Q2L are to be chosen depending on the motor characteristics.

For example, STP30NE03L are 30V, 30A devices with gate capacitance of about 1nF. For these MOS, 22nF bootstrap capacitors are adequate.

Resistors R1 to R4 are used to control the rise and fall times on the MOS gates, and are also useful to avoid oscillation of the gate voltage due to the parasitic inductance of lines in conjunction with the gate capacitance. Typical values for resistors R1 to R4 are from 10 to 100 ohms.

Capacitor C6 is used to store energy and to filter the voltage across the bridge.

Applications:

Small domestic motorized equipments, battery-powered electrical tools, ...

Complete, μC driven system

The next schematic (figure 10) shows a complete system driven by a μC .

The auto-reload timer feature of ST6 μC family is used to easily generate the PWM command signal (TD340 internal generator is not used, CF pin is connected to ground).

Transil diode D3 can be added as a security to avoid overvoltage transients if the MOS are all driven off when the motor is running. For example, it can happen if TD340 is put in standby or disable state while motor is running.

Applications:

- Automotive: advanced window lift systems, wiper systems, ...

- Industrial: battery-powered motor systems, electric door opening, ...

Figure 9: Simple Standalone System

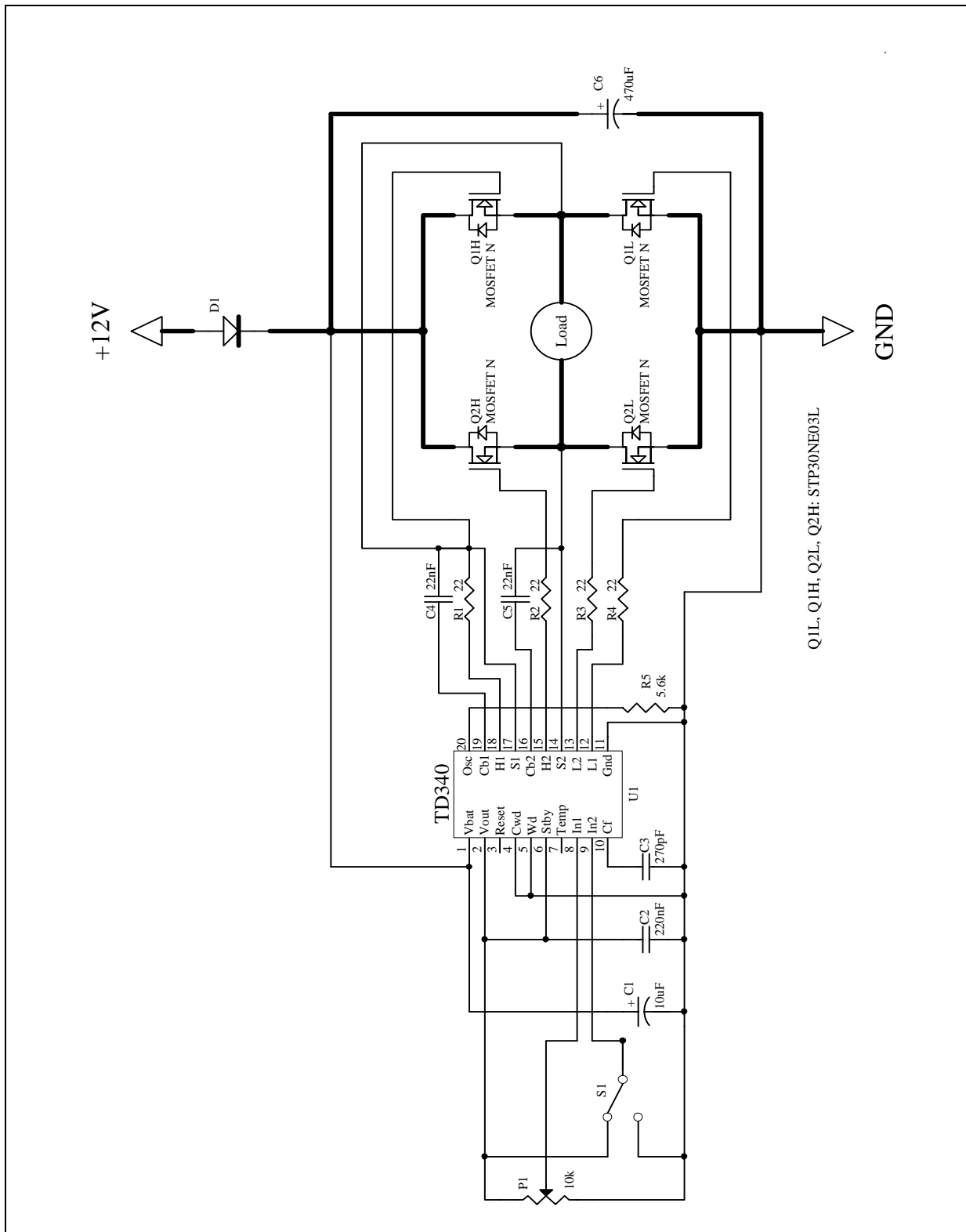
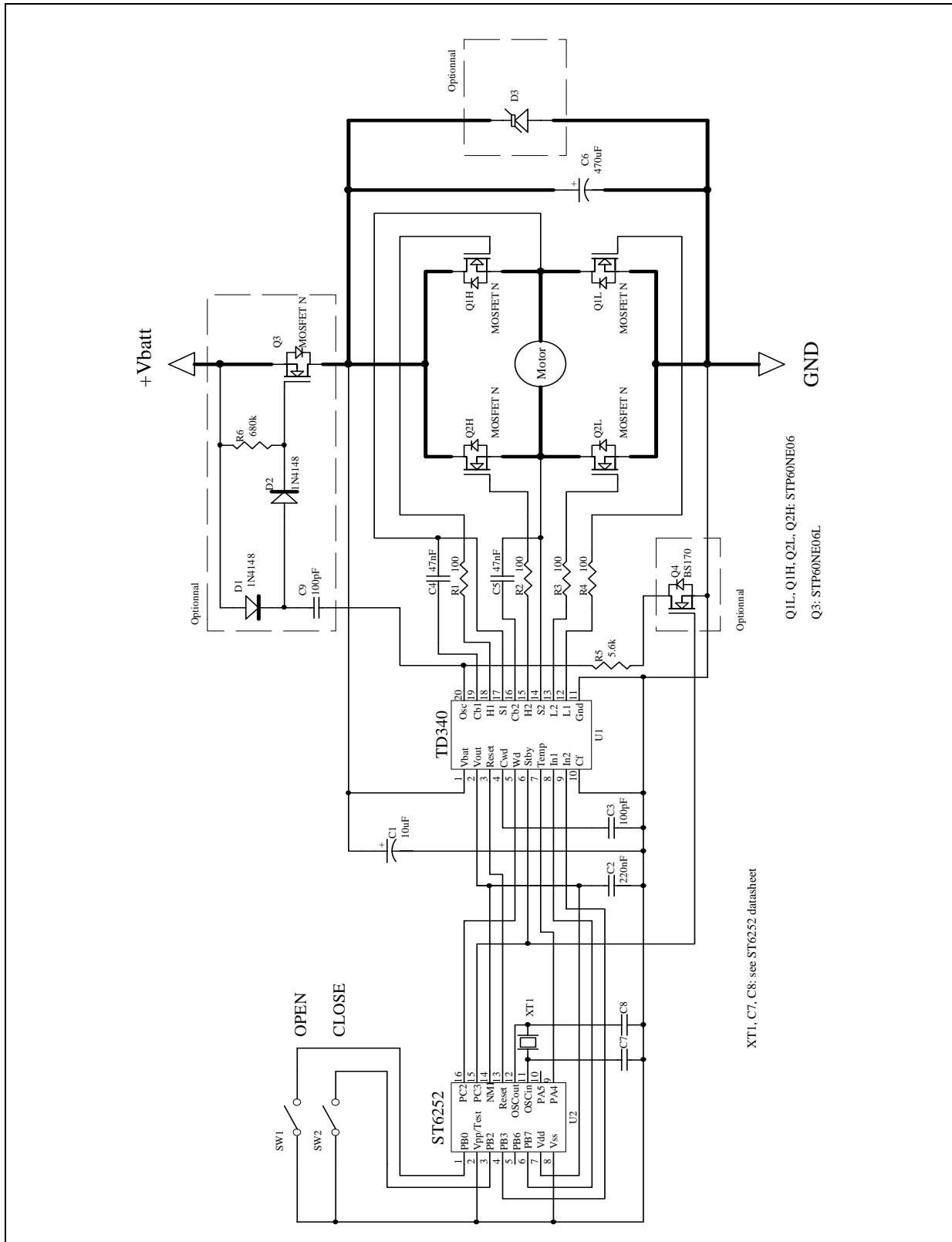
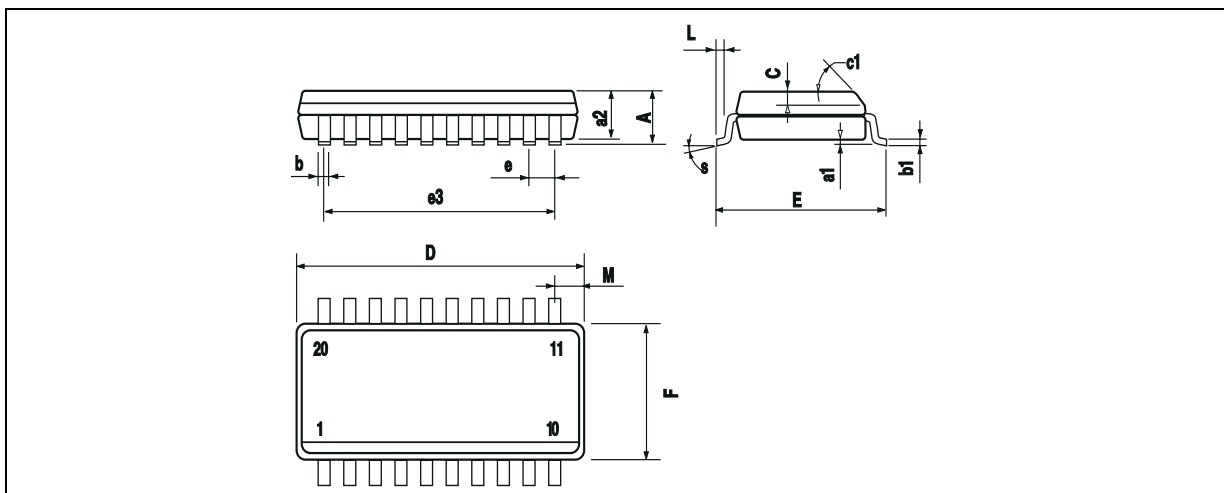

Figure 10: Complete, μ C Driven System



PACKAGE MECHANICAL DATA
20 PINS - PLASTIC MICROPACKAGE (SO)



Dim.	Millimeters			Inches		
	Min.	Typ.	Max.	Min.	Typ.	Max.
A			2.65			0.104
a1	0.1		0.3	0.004		0.012
a2			2.45			0.096
b	0.35		0.49	0.014		0.019
b1	0.23		0.32	0.009		0.013
C		0.5			0.020	
c1	45° (typ.)					
D	12.6		13.0	0.496		0.512
E	10		10.65	0.394		0.419
e		1.27			0.050	
e3		11.43			0.450	
F	7.4		7.6	0.291		0.299
L	0.5		1.27	0.020		0.050
M			0.75			0.030
S	8° (max.)					

Information furnished is believed to be accurate and reliable. However, STMicroelectronics assumes no responsibility for the consequences of use of such information nor for any infringement of patents or other rights of third parties which may result from its use. No license is granted by implication or otherwise under any patent or patent rights of STMicroelectronics. Specifications mentioned in this publication are subject to change without notice. This publication supersedes and replaces all information previously supplied. STMicroelectronics products are not authorized for use as critical components in life support devices or systems without express written approval of STMicroelectronics.

© The ST logo is a registered trademark of STMicroelectronics

© 2001 STMicroelectronics - Printed in Italy - All Rights Reserved
STMicroelectronics GROUP OF COMPANIES

Australia - Brazil - Canada - China - Finland - France - Germany - Hong Kong - India - Israel - Italy - Japan - Malaysia
Malta - Morocco - Singapore - Spain - Sweden - Switzerland - United Kingdom - United States

© <http://www.st.com>

