

MOTOR SPEED REGULATOR WITH THERMAL SHUT-DOWN

The TDA1059B is a monolithic integrated circuit with a current limiter and with good thermal characteristics in a TO-126 plastic package for easy mounting. It is intended to regulate the speed of d.c. motors in record players, cassette recorders and car cassette recorders.

QUICK REFERENCE DATA

Supply voltage	$V_P = V_{2-1}$	typ.	9 V 3,3 to 16 V
Internal reference voltage	V_{ref}	typ.	1,3 V
Drop-out voltage	V_{3-1}	typ.	1,8 V
Limited output current	I_{3lim}	typ.	0,6 A
Multiplication coefficient	k	typ.	9

PACKAGE OUTLINE

Dimensions in mm

Fig. 1 TO-126 (SOT-32).

Pin 1 connected to metal part of mounting surface.

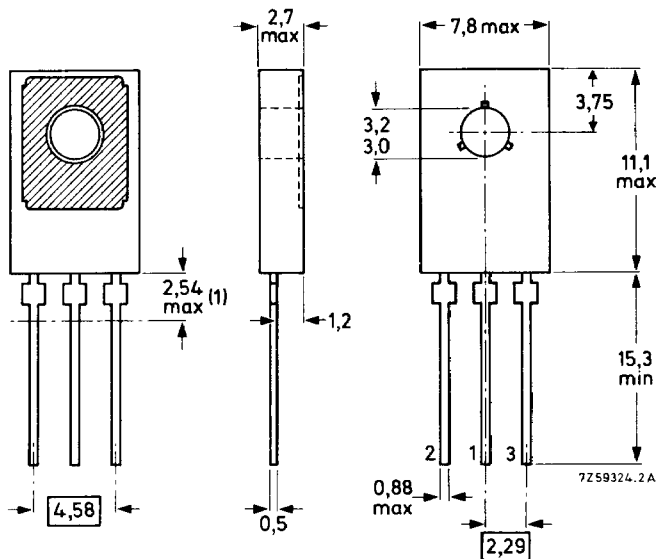

(1) Within this region the cross-section of the leads is uncontrolled.

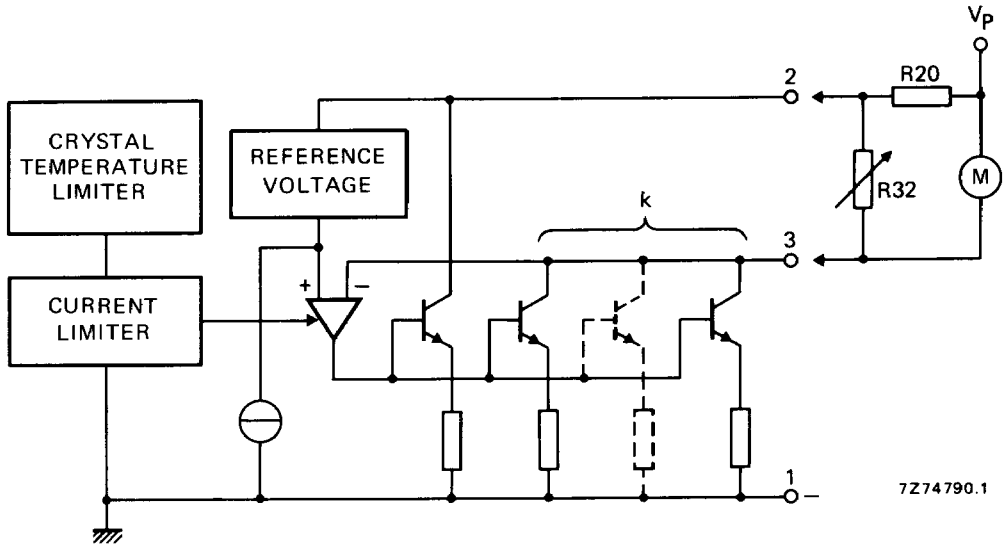

Fig. 2 Functional diagram.

RATINGS

Limiting values in accordance with the Absolute Maximum System (IEC 134)

Supply voltage	$V_p = V_{2-1}$	max.	16 V
Storage temperature	T_{stg}		-55 to + 150 °C
Operating ambient temperature (see Fig. 3 and note)	T_{amb}		-25 to + 130 °C

THERMAL RESISTANCE

From junction to case	$R_{th j-c}$	=	10 K/W
From junction to ambient	$R_{th j-a}$	=	100 K/W

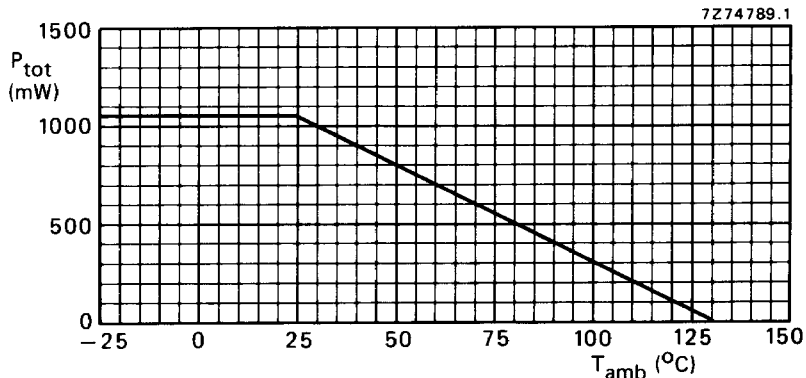

Fig. 3 Power derating curve.

Note

At ambient temperatures above 130 °C, the crystal temperature limiter decreases the internal power consumption.

CHARACTERISTICS

$V_P = 9 \text{ V}$; $T_{\text{amb}} = 25 \text{ }^\circ\text{C}$; $R_{20} = 0$; heatsink with $R_{\text{th}} = 100 \text{ K/W}$ and after thermal stabilization; unless otherwise specified; see test circuit Fig. 4.

		min.	typ.	max.
Supply voltage	$V_P = V_{2-1}$	3,3	9	16 V
Internal reference voltage $V_P = 3,3 \text{ V}$; $I_3 = 80 \text{ mA}$	V_{ref}	1,24	1,3	1,36 V
Drop-out voltage $I_3 = 80 \text{ mA}$; $\Delta V_{\text{ref}} = 5\%$	V_{3-1}	—	1,8	2,06 V
Quiescent current; $I_3 = 0$	I_q	1,8	2,3	2,8 mA
Limited output current*	$I_{3\text{lim}}$	0,3	0,6	1 A
Multiplication coefficient $I_3 = 50 \text{ mA} \pm 10 \text{ mA}$	$k = \frac{\Delta I_3}{\Delta I_2}$	8,5	9	9,5
Line regulation				
$V_P = 3,3 \text{ to } 16 \text{ V}$ at $I_3 = 50 \text{ mA}$				
reference voltage variation	$\frac{\Delta V_{\text{ref}}}{V_{\text{ref}}} / \Delta V_P$	-0,115	0	+0,115 %/V
multiplication coefficient variation $I_3 = 50 \pm 10 \text{ mA}$	$\frac{\Delta k}{k} / \Delta V_P$	—	0,86	— %/V
input current variation; $I_3 = 50 \text{ mA}$	$\frac{\Delta I_2}{\Delta V_P}$	-15	0	+20 $\mu\text{A/V}$
Load regulation				
reference voltage variation $I_3 = 20 \text{ to } 80 \text{ mA}$	$\frac{\Delta V_{\text{ref}}}{V_{\text{ref}}} / \Delta I_3$	0	19	38,5 %/A
multiplication coefficient variation $I_3 = 30 \pm 10 \text{ to } 70 \pm 10 \text{ mA}$	$\frac{\Delta k}{k} / \Delta I_3$	-0,075	0	+0,075 %/mA
Temperature coefficient				
$I_3 = 50 \text{ mA}$; $T_{\text{amb}} = -15 \text{ to } +65 \text{ }^\circ\text{C}$				
reference voltage variation	$\frac{\Delta V_{\text{ref}}}{V_{\text{ref}}} / \Delta T_{\text{amb}}$	-0,03	0	+0,03 %/K
multiplication coefficient variation $\Delta I_3 = \pm 10 \text{ mA}$	$\frac{\Delta k}{k} / \Delta T_{\text{amb}}$	—	0,008	— %/K
input current variation	$\frac{\Delta I_2}{\Delta T_{\text{amb}}}$	-2	0	+2 $\mu\text{A/K}$

* If the motor is stopped by a mechanical brake, the current limitation is effective in the supply voltage range. If the motor is short-circuited, the TDA1059B will be damaged if the supply voltage is higher than 10 V due to parasitic oscillations.

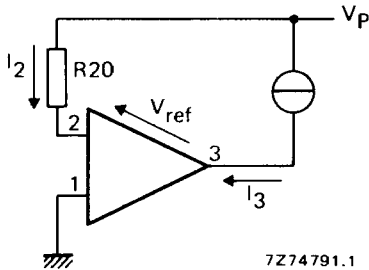
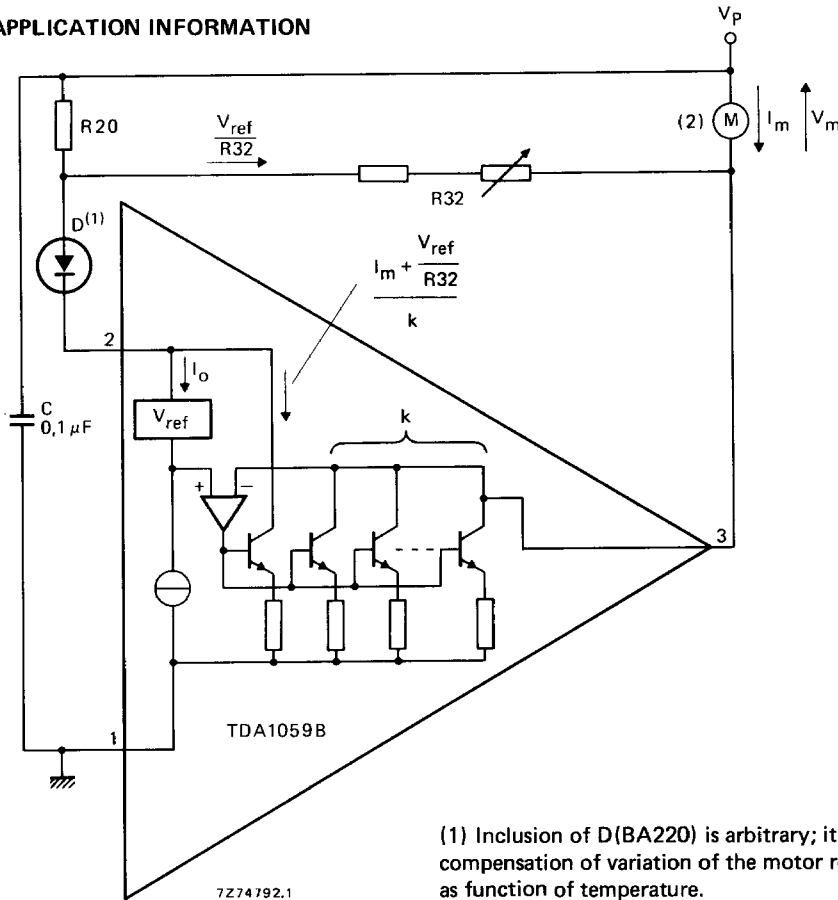

Fig. 4 Test circuit.

Note

For start operation: V_{ref} must start with final $V_p = 6,7$ V and a time constant of $3\tau = 100$ ms in which $\tau = R.C$; R = source impedance, C = by-pass capacitor.

APPLICATION INFORMATION



(1) Inclusion of D(BA220) is arbitrary; it permits compensation of variation of the motor resistance as function of temperature.

(2) Motor example (without diode D):

Catalogue no. 9904 120 01806; $n = 2000$ rev/min; $R20 = 180 \Omega (\pm 2\%)$; $R32 = 100 \Omega + 100 \Omega$ (variable).

Fig. 5 Example of using the TDA1059B in a d.c. motor speed regulation circuit.

Motor equations

$$\begin{aligned}
 E_m &= \alpha_1 n && \text{where: } \alpha_1, \alpha_2 = \text{motor constant} \\
 I_m &= \alpha_2 r && n = \text{number of revolutions} \\
 V_m &= E_m + R_m I_m && r = \text{motor torque} \\
 &&& E_m = \text{back electromotive force} \\
 &&& R_m = \text{motor resistance}
 \end{aligned}$$

The back electromotive force (E_m) in Fig. 5 can be expressed (excluding diode D) as:

$$E_m = \left(\frac{R_{20}}{k} - R_m \right) I_m + V_{ref} \left\{ 1 + \frac{R_{20}}{R_{32}} \left(1 + \frac{1}{k} \right) \right\} + R_{20} I_o$$

and including diode D, as:

$$E_m = \left(\frac{R_{20}}{k} - R_m \right) I_m + (V_{ref} + V_D) \left\{ 1 + \frac{R_{20}}{R_{32}} \left(1 + \frac{1}{k} \right) \right\} + R_{20} I_o$$

Speed regulation is constant when E_m is independent of I_m variations; this will be obtained when $R_{20} = kR_m$.

E_m , and therefore the motor speed, is regulated by R_{32} . A practical condition for stability is $R_{20} < kR_m$.