

VERTICAL DEFLECTION CIRCUIT

- RAMP GENERATOR
- INDEPENDENT AMPLITUDE ADJUSTEMENT
- BUFFER STAGE
- POWER AMPLIFIER
- FLYBACK GENERATOR
- INTERNAL REFERENCE VOLTAGE
- THERMAL PROTECTION

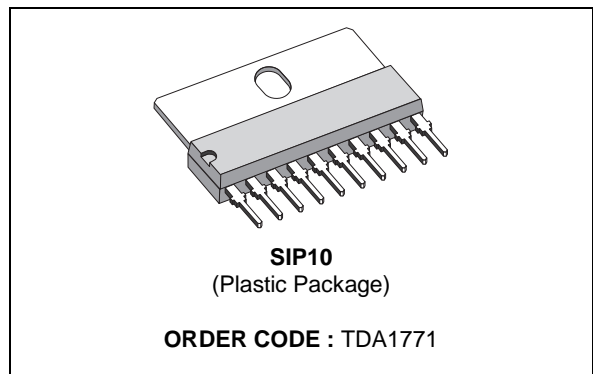

DESCRIPTION

The TDA1771 is a monolithic integrated circuit in SIP10 package.

It is a full performance and very efficient vertical deflection circuit intended for direct drive of a TV picture tube in Color and B & W television as well as in Monitor and Data displays.

PIN CONNECTIONS (top view)

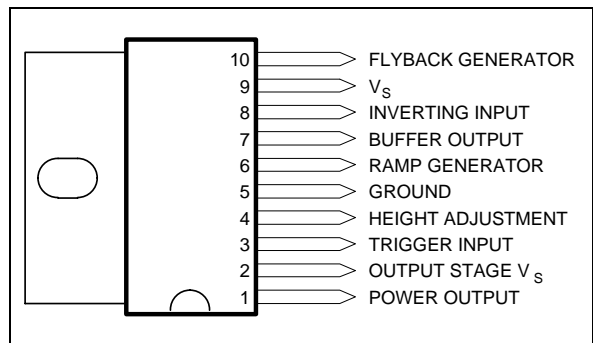

1771-01.EPS

BLOCK DIAGRAM

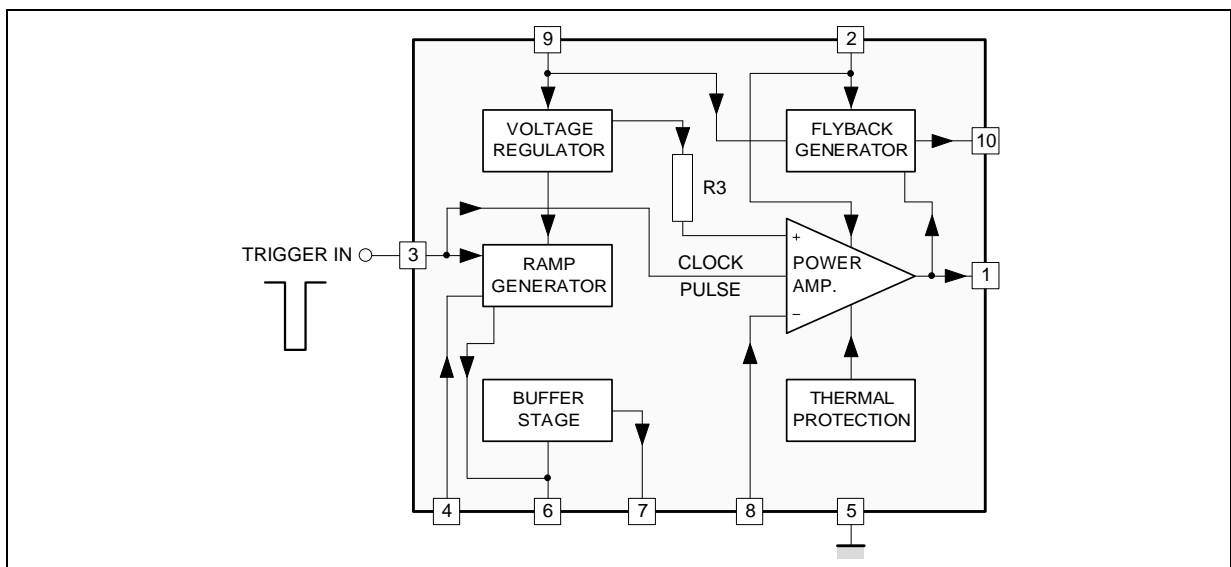

1771-02.EPS

ABSOLUTE MAXIMUM RATINGS

Symbol	Parameter	Value	Unit
V _S	Supply Voltage	30	V
V ₁ , V ₂	Flyback Peak Voltage	65	V
V ₃	Trigger Input Voltage	20	V
V ₈	Amplifier Input Voltage	GND to V _S	V
I ₀	Output Peak to Peak Current (non repetitive t = 2ms)	6	A
I ₀	Output Peak to Peak Current t > 10μs	4	A
I ₁₀	Pin 10 DC Current at V ₁ < V ₉	100	mA
I ₁₀	Pin 10 Peak to Peak Current @ t _{fly} < 1.5ms	3	A
P _{tot}	Total Power Dissipation @ T _{tab} = 60°C	9	W
T _S , T _J	Storage and Junction Temperature	- 40, + 150	°C

1771-01.TBL

THERMAL DATA

Symbol	Parameter	Value	Unit
R _{th(j-tab)}	Thermal Resistance Junction-tab	Max. 10	°C/W
R _{th(j-a)}	Thermal Resistance Junction-ambient	Max. 70	°C/W

1771-02.TBL

ELECTRICAL CHARACTERISTICS (T_{amb} = 25°C unless otherwise specified)

Symbol	Parameter	Test Conditions	Min.	Typ.	Max.	Unit
DC (V _S = 30V)						
I ₂	Pin 2 Quiescent Current	I ₁ = 0, I ₁₀ = 0		16	36	mA
I ₉	Pin 9 Quiescent Current	I ₁ = 0, I ₁₀ = 0		15	30	mA
- I ₆	Ramp Generator Bias Current	V ₆ = 0			0.5	μA
- I ₆	Ramp Generator Current	V ₆ = 0, - I ₄ = 20μA	18.5	20	21.5	μA
dI ₆ /I ₆	Ramp Gener. Linearity	V ₆ = 0 to 15V, - I ₄ = 20μA		0.2	1	%
V ₁	Quiescent Output Voltage	R _a = 30kΩ, R _b = 10kΩ, V _S = 30V	17.0	17.8	18.6	V
		R _a = 6.8kΩ, R _b = 10kΩ, V _S = 15V	7.2	7.5	7.8	V
V _{1L}	Out Saturation Voltage to GND	I ₁ = 0.5A		0.5	1	V
		I ₁ = 1.2A		1	1.4	V
V _{1H}	Out Saturation Voltage to V _S	- I ₁ = 0.5A		1.1	1.6	V
		- I ₁ = 1.2A		1.6	2.2	V
V ₄	Reference Voltage	- I ₄ = 20μA	6.3	6.6	6.9	V
dV ₄ /V _S	Reference Voltage Drift Versus V _S	V _S = 10V to 30V		1	2	mV/V
dV ₄ /dI ₄	Reference Voltage Drift Versus I ₄	I ₄ = 10μA to 30μA		1.5	2	mV/μA
V _r	Internal Ref. Voltage		4.26	4.40	4.54	V
G _v	Output Stage Open Loop Gain	f = 100Hz		60		dB
V _{f5}	V ₉₋₁₀ Saturation Voltage	- I ₁₀ = 1.2A		1.5	2.5	V
V ₁₀	Pin 10 Scanning Voltage	I ₁₀ = 20mA		1.7	3	V
V ₃	Trigger Input Threshold	(see note 1)	2.6	3.0	3.4	V
I ₃	Trigger Input Bias Current	V _{IN} = V ₃ - 0.2V			30	μA
t ₃	Trigger Input Width	(see note 2)	20	60	th	μS

1771-03.TBL

Notes : 1. The trigger input circuit can accept, with a metal option, positive and negative going input pulses.

2. $th = \frac{1.2 \cdot t_s}{V_{PP}}$ where t_s is the vertical period and V_{PP} is ramp amplitude at Pin 6

ELECTRICAL CHARACTERISTICS ($T_{amb} = 25^{\circ}\text{C}$ unless otherwise specified) (continued)

Symbol	Parameter	Test Conditions	Min.	Typ.	Max.	Unit
DC ($V_S = 24\text{V}$)						
V_S	Operating Supply Voltage Range		10		30	V
I_1	Peak-to-peak Operating Current Range		0.4		2.5	A
I_S	Supply Current	$I_Y = 2.4A_{pp}$		315		mA
V_1	Flyback Voltage	$I_Y = 2.4A_{pp}$		51		V
V_7	Sawtooth Pedestall Voltage			1.85		V
T_{JS}	Junction Temp. for Thermal Shutdown			145		$^{\circ}\text{C}$

1771-04.TBL

APPLICATION CIRCUIT

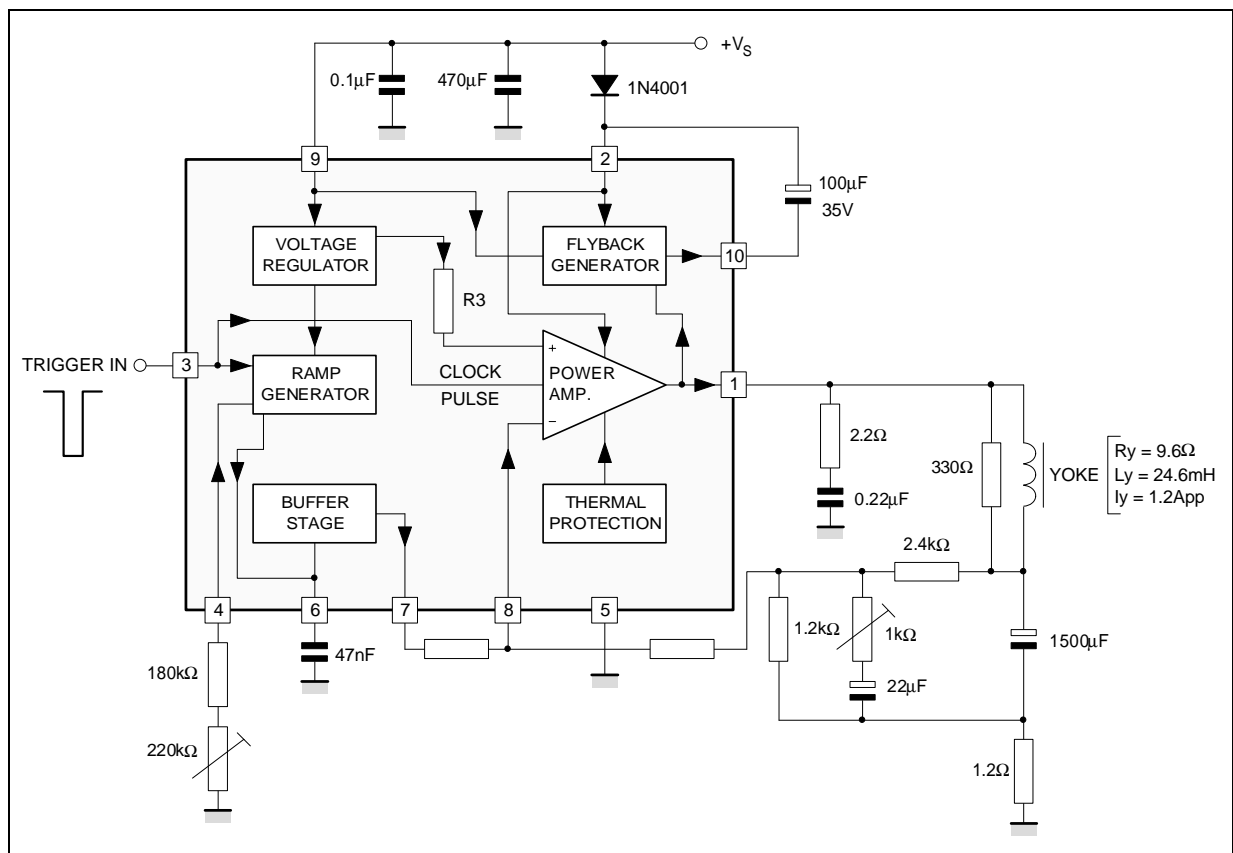

1771-03.EPS

PACKAGE MECHANICAL DATA
10 PINS - PLASTIC SIP

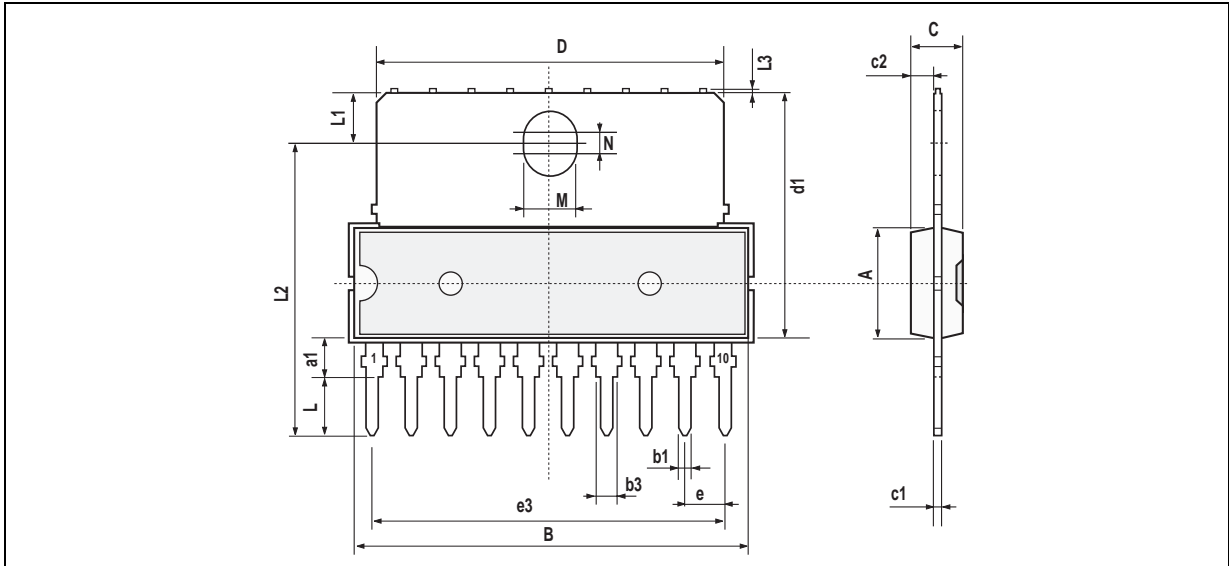

PM-SIP10.EPS

Dimensions	Millimeters			Inches		
	Min.	Typ.	Max.	Min.	Typ.	Max.
A			7.1			0.280
a1	2.7		3	0.106		0.118
B			24.8			0.976
b1		0.5			0.020	
b3	0.85		1.6	0.033		0.063
C		3.3			0.130	
c1		0.43			0.017	
c2		1.32			0.052	
D			23.7			0.933
d1		14.5			0.571	
e		2.54			0.100	
e3		22.86			0.900	
L	3.1			0.122		
L1		3			0.118	
L2		17.6			0.693	
L3			0.25			0.010
M		3.2			0.126	
N		1			0.039	

SIP10.TBL

Information furnished is believed to be accurate and reliable. However, SGS-THOMSON Microelectronics assumes no responsibility for the consequences of use of such information nor for any infringement of patents or other rights of third parties which may result from its use. No licence is granted by implication or otherwise under any patent or patent rights of SGS-THOMSON Microelectronics. Specifications mentioned in this publication are subject to change without notice. This publication supersedes and replaces all information previously supplied. SGS-THOMSON Microelectronics products are not authorized for use as critical components in life support devices or systems without express written approval of SGS-THOMSON Microelectronics.

© 1994 SGS-THOMSON Microelectronics - All Rights Reserved

Purchase of I²C Components of SGS-THOMSON Microelectronics, conveys a license under the Philips I²C Patent. Rights to use these components in a I²C system, is granted provided that the system conforms to the I²C Standard Specifications as defined by Philips.

SGS-THOMSON Microelectronics GROUP OF COMPANIES

Australia - Brazil - China - France - Germany - Hong Kong - Italy - Japan - Korea - Malaysia - Malta - Morocco
The Netherlands - Singapore - Spain - Sweden - Switzerland - Taiwan - Thailand - United Kingdom - U.S.A.