

TV VERTICAL DEFLECTION OUTPUT CIRCUIT

The functions incorporated are :

- POWER AMPLIFIER
- FLYBACK GENERATOR
- REFERENCE VOLTAGE
- THERMAL PROTECTION

DESCRIPTION

The TDA2170 is a monolithic integrated circuit in 11-lead Multiwatt® package. It is a high efficiency power booster for direct driving of vertical windings of TV yokes. It is intended for use in Colour and B & W television receivers as well as in monitors and displays.

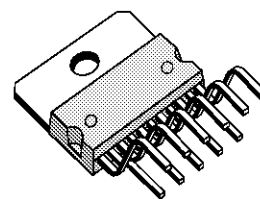

MULTIWATT 11
(Plastic Package)

ORDER CODE : TDA2170

PIN CONNECTIONS

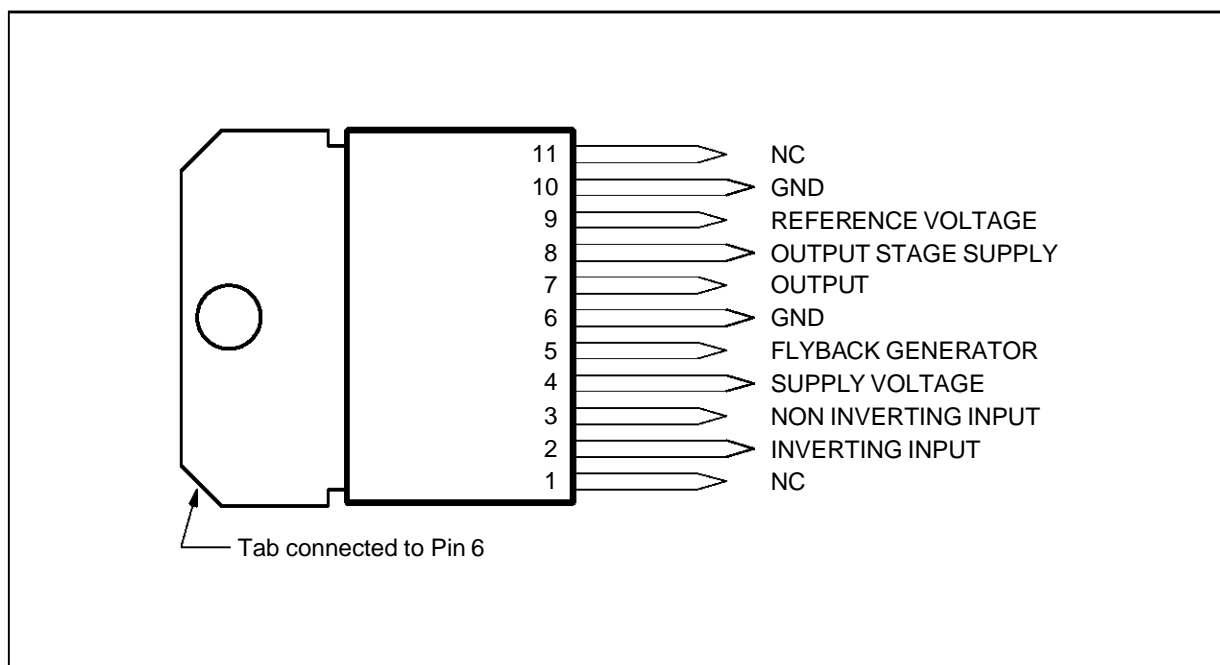

2170-01.EPS

TDA2170

BLOCK DIAGRAM

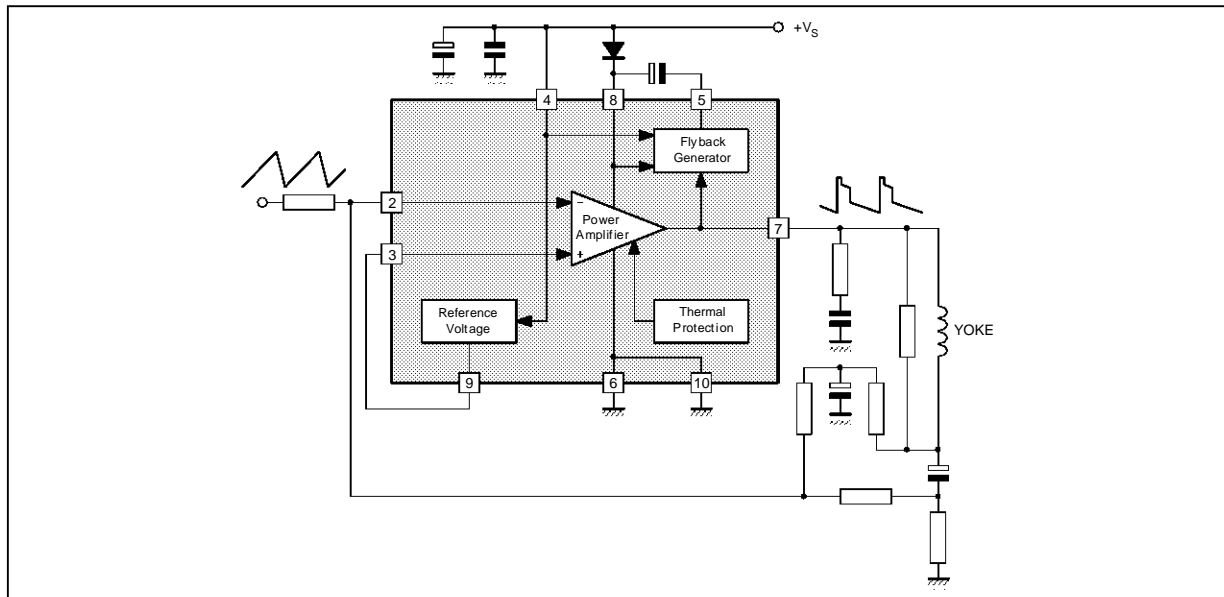

2170-02.EPS

SCHEMATIC DIAGRAM

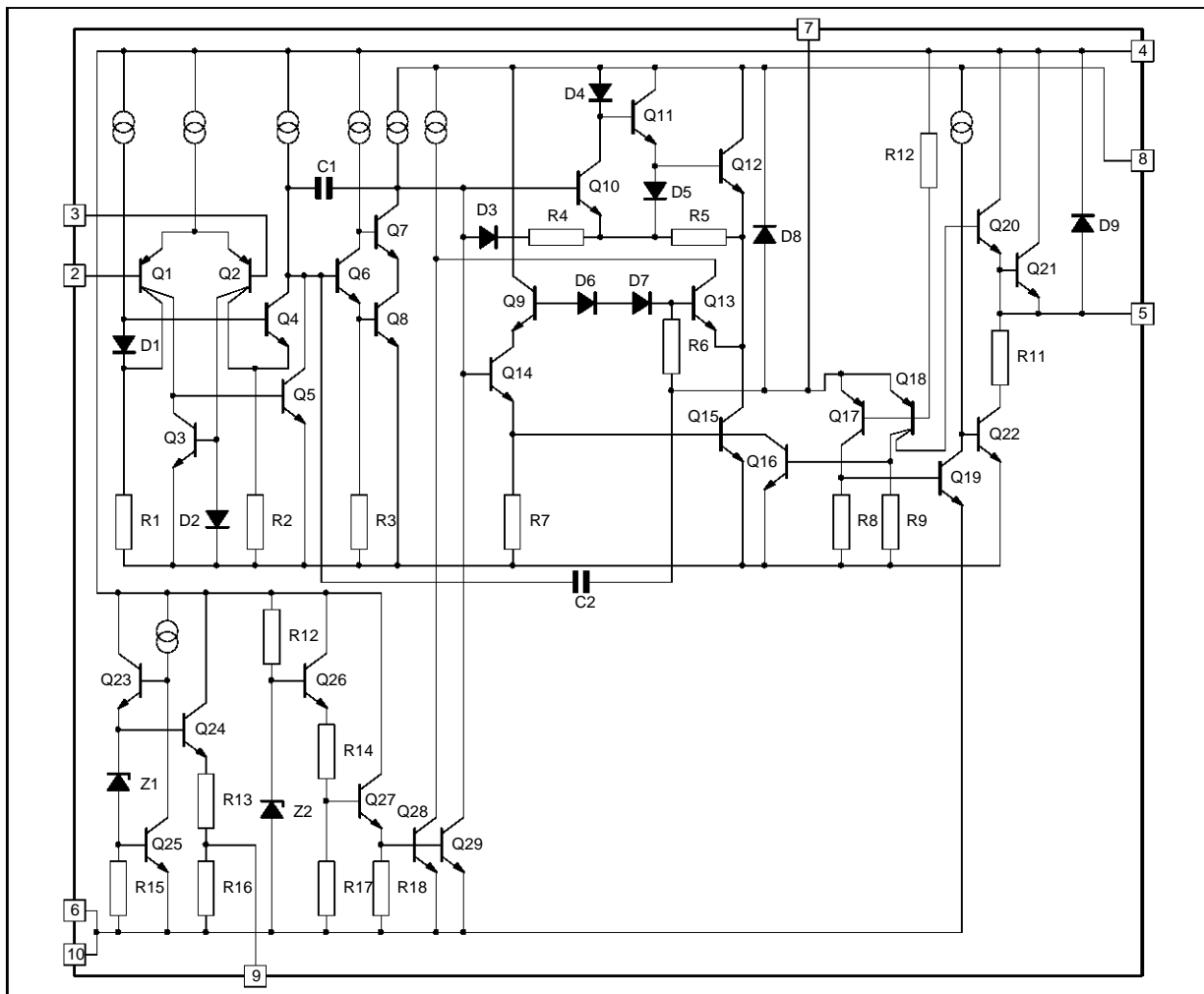

2170-03.EPS

ABSOLUTE MAXIMUM RATINGS

Symbol	Parameter	Value	Unit
V_s	Supply Voltage (pin 4)	35	V
V_7, V_8	Flyback Peak Voltage	60	V
V_5	Voltage at Pin 5	$+V_s$	
V_2, V_3	Amplifier Input Voltage	$+V_s - 0.5$	V
I_o	Output Peak Current (non repetitive, $t = 2$ msec)	2.5	A
I_o	Output Peak Current at $f = 50$ Hz, $t \leq 10$ μ sec	3	A
I_o	Output Peak Current at $f = 50$ Hz, $t > 10$ μ sec	2	A
I_5	Pin 5 DC Current at $V_7 < V_4$	100	mA
I_5	Pin 5 Peak to Peak Flyback Current at $f = 50$ Hz, $t_{fly} \leq 1.5$ msec	3	A
P_{tot}	Total Power Dissipation at $T_{case} = 60$ °C	30	W
T_{stg}, T_j	Storage and Junction Temperature	- 40 to 150	°C

2170-01.TBL

THERMAL DATA

Symbol	Parameter	Value	Unit
$R_{th(j-c)}$	Thermal Resistance Junction-case	Max 3	°C/W
$R_{th(j-a)}$	Thermal Resistance Junction-ambient	Max 40	°C/W

2170-02.TBL

ELECTRICAL CHARACTERISTICS

(refer to the test circuits, $V_s = 35$ V, $T_{amb} = 25$ °C unless otherwise specified)

Symbol	Parameter	Test Conditions	Min.	Typ.	Max.	Unit	Fig.
I_4	Pin 4 Quiescent Current	$I_5 = 0$; $I_7 = 0$; $V_3 = 3$ V		8	16	mA	1a
I_8	Pin 8 Quiescent Current	$I_5 = 0$; $I_7 = 0$; $V_3 = 3$ V		16	36	mA	1a
I_3	Amplifier Input Bias Current	$V_3 = 1$ V		- 0.1	- 1	μ A	1a
I_2	Amplifier Input Bias Current	$V_2 = 1$ V		- 0.1	- 1	μ A	1a
V_9	Reference Voltage	$I_9 = 0$		2.2		V	1a
$\frac{\Delta V_9}{\Delta V_s}$	Reference Voltage Drift vs. Supply Voltage	$V_s = 15$ to 30 V		1	2	mV/V	1a
V_{5L}	Pin 5 Saturation Voltage to GND	$I_5 = 20$ mA		1		V	1c
V_7	Quiescent Output Voltage	$V_s = 35$ V; $R_a = 13$ k Ω		18		V	1d
		$V_s = 15$ V; $R_a = 13$ k Ω		7.5		V	1d
V_{7L}	Output Saturation Voltage to GND	$I_7 = 1.2$ A		1	1.4	V	1c
		$I_7 = 0.7$ A		0.7	1	V	1c
V_{7H}	Output Saturation Voltage to Supply	- $I_7 = 1.2$ A		1.6	2.2	V	1b
		- $I_7 = 0.7$ A		1.3	1.8	V	1b
R_9	Reference Voltage Output Resistance			2.1		k Ω	
T_j	Junction Temperature for Thermal Shut Down			140		°C	

2170-03.TBL

Figure 1 : DC Test Circuits

Figure 1a : Measurement of I_2 ; I_3 ; I_4 ; I_8 ; I_9 ; $\Delta V_9/\Delta V_S$; R_9

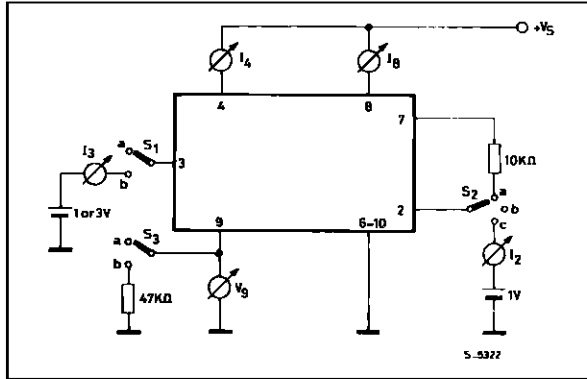

2170-04.EPS

Figure 1b : Measurement of V_{7H}

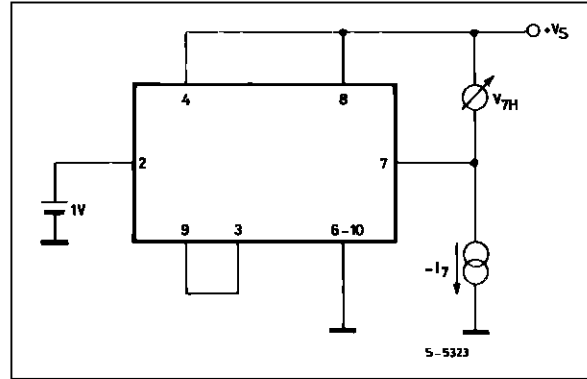

2170-05.EPS

S1 : (a) I_2 ; (b) I_3 , I_4 and I_8 .
 S2 : (a) I_4 and I_8 ; (b) I_3 ; (c) I_2 .
 S3 : (a) I_2 , I_3 , I_4 , I_8 , I_9 and V_9 ; (b) R_9 .

Figure 1c : Measurement of V_{5L} , V_{7L} .

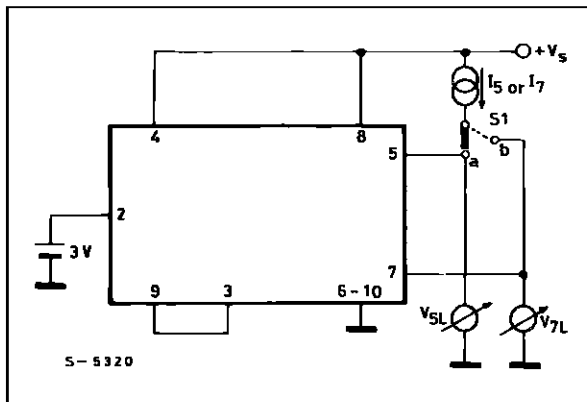

2170-06.EPS

Figure 1d : Measurement of V_7 .

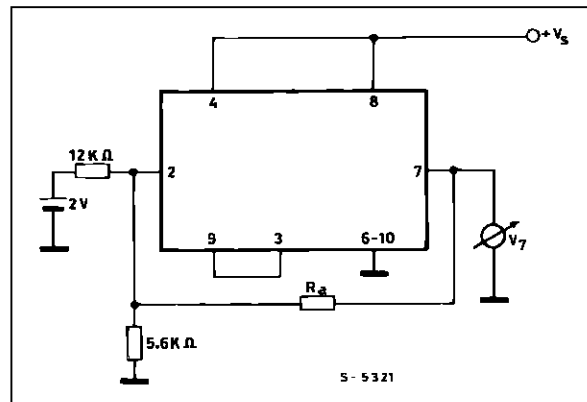

2170-07.EPS

S1 : (a) V_{5L} ; (b) V_{7L} .

Figure 2 : Application Circuit

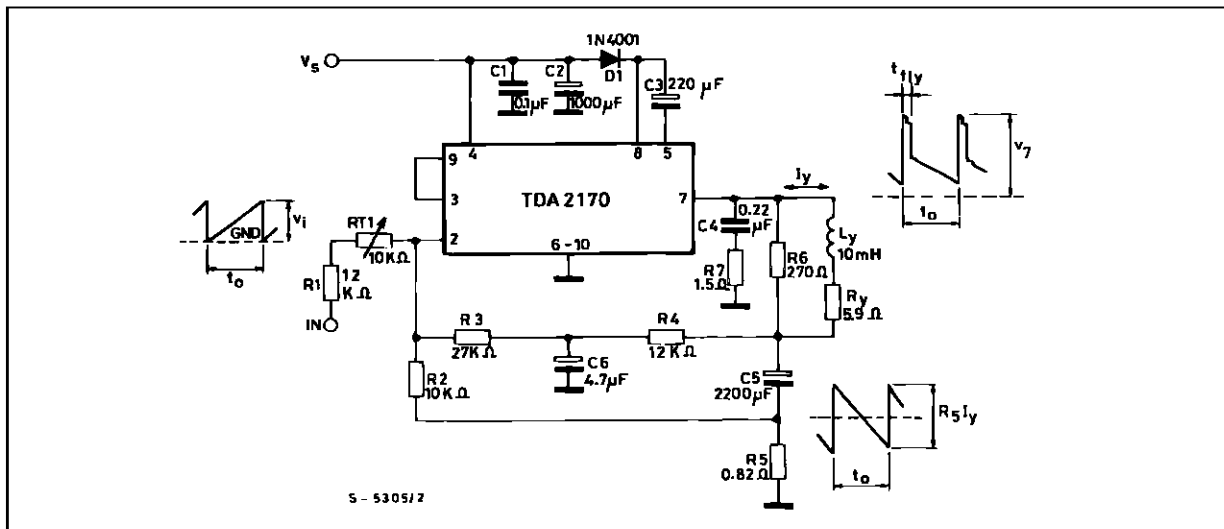

S - 5305/2

2170-08.EPS

Figure 3 : PC Board and Component Layout (1:1 scale)

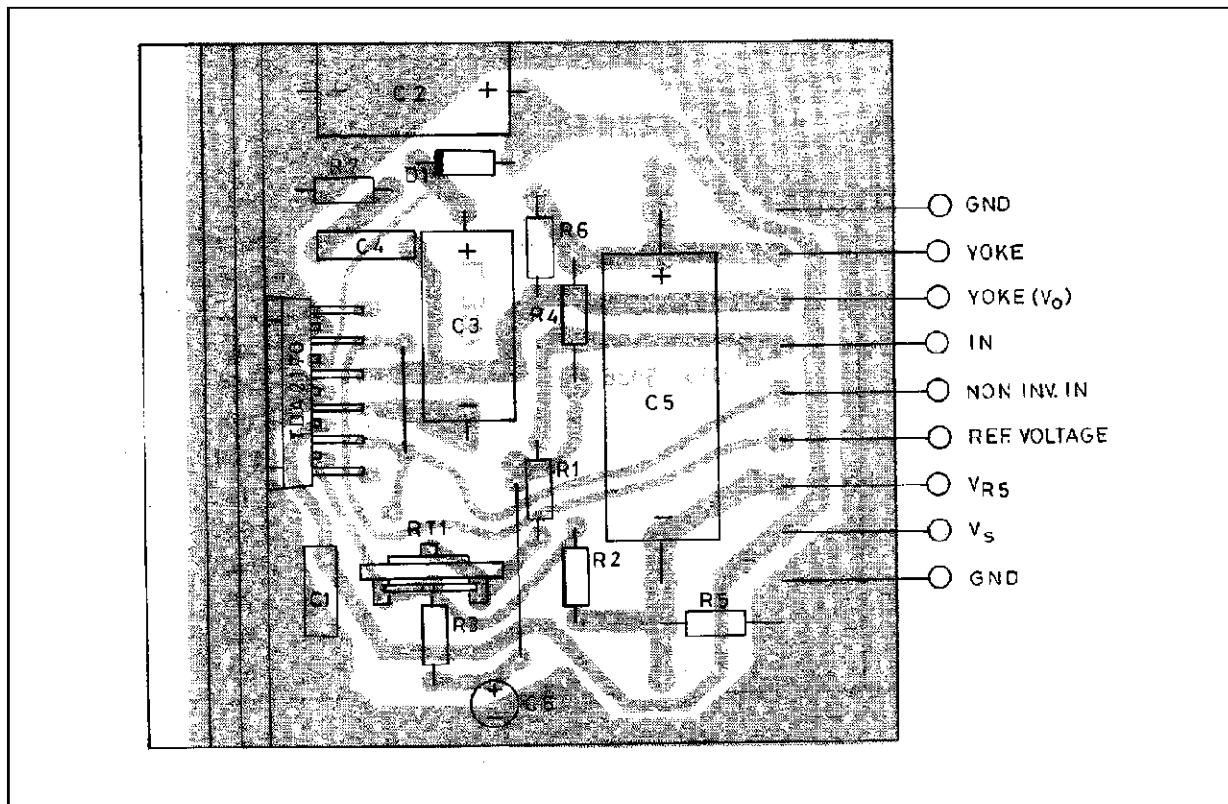

COMPONENTS LIST FOR TYPICAL APPLICATIONS

Component	110° TVC 5.9 Ω / 10 mH 1.95 App	110° TVC 9.6 Ω / 24.6 mH 1.2 App	90° TVC 15 Ω / 30 mH 0.82 App	Unit
RT1	10	4.7	10	kΩ
R1	12	10	12	kΩ
R2	10	5.6	5.6	kΩ
R3	27	12	18	kΩ
R4	12	8.2	5.6	kΩ
R5	0.82	1	1	Ω
R6	270	330	330	Ω
R7	1.5	1.5	1.5	Ω
D1	1N 4001	1N 4001	1N 4001	–
C1	0.1	0.1	0.1	μF
C2 el.	1000/25 V	470/25 V	470/25 V	μF
C3 el.	220/25 V	220/25 V	220/25 V	μF
C4	0.22	0.22	0.22	μF
C5 el.	2200/25 V	2200/25 V	1000/16 V	μF
C6 el.	4.7/16 V	4.7/16 V	10/16 V	μF

TYPICAL PERFORMANCES

Parameter	110° TVC 5.9 Ω / 10 mH	110° TVC 9.6 Ω / 27 mH	90° TVC 15 Ω / 30 mH	Unit
V _s – Supply Voltage	24	22.5	25	V
I _s – Current	280	175	125	mA
t _{fly} – Flyback Time	0.6	1	0.7	ms
* P _{tot} – Power Dissipation	4.2	2.5	2.05	W
* R _{th c-a} – Heatsink	7	13	16	°C/W
T _{amb}	60	60	60	°C
T _{j max}	110	110	110	°C
t _o	20	20	20	ms
V _i	2.5	2.5	2.5	V _{PP}
V ₇	50	47	52	V _P

* Worst case condition.

MOUNTING INSTRUCTIONS

The power dissipated in the circuit must be removed by adding an external heatsink.

Thanks to the MULTIWATT® package attaching the heatsink is very simple, a screw or a compression spring (clip) being sufficient.

Between the heatsink and the package it is better to insert a layer of silicon grease, to optimize the thermal contact ; no electrical isolation is needed between the two surfaces.

Figure 2 : Application Circuit

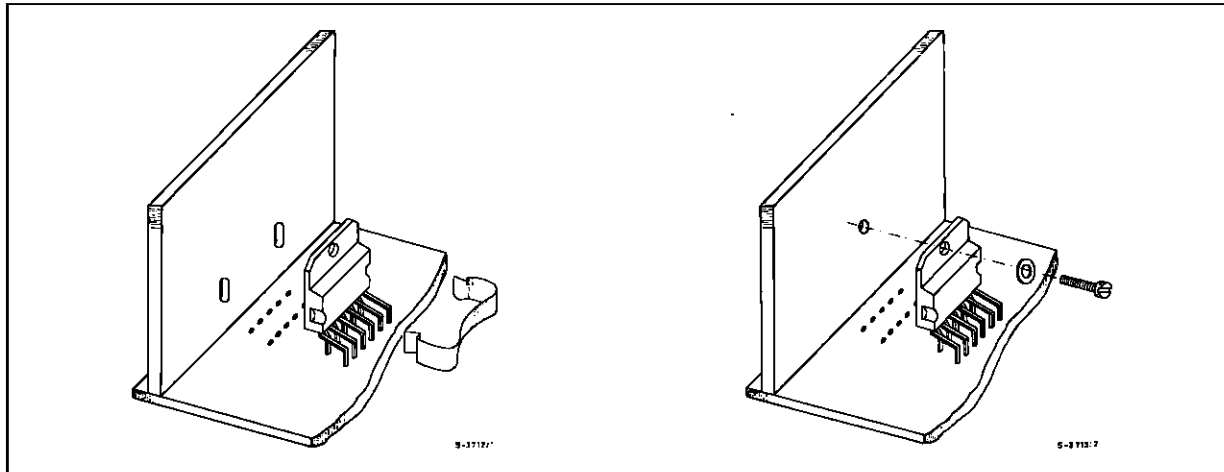
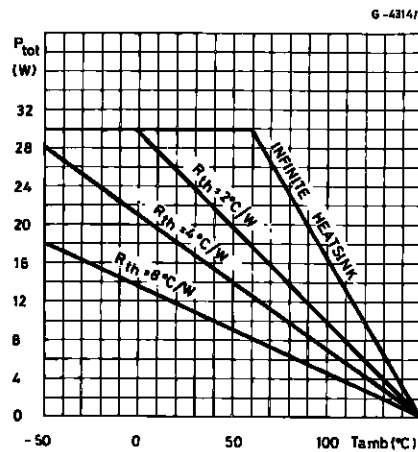
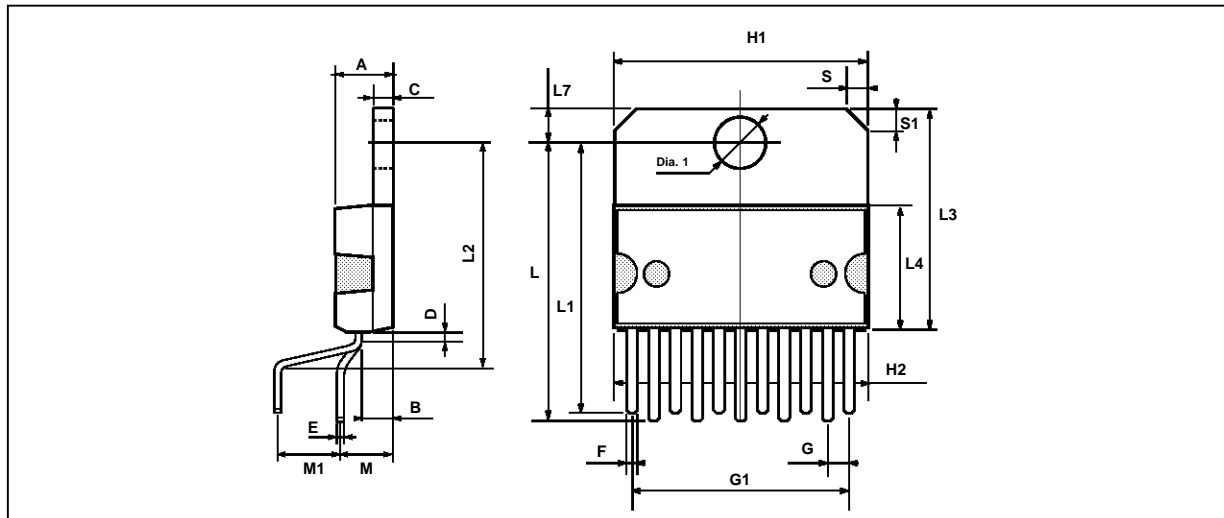

Figure 5 : Maximum Allowable Power Dissipation versus Ambient Temperature



PACKAGE MECHANICAL DATA
11 PINS - PLASTIC MULTIWATT



PMMUL11V.EPS

Dimensions	Millimeters			Inches		
	Min.	Typ.	Max.	Min.	Typ.	Max.
A			5			0.197
B			2.65			0.104
C			1.6			0.063
E	0.49		0.55	0.019		0.022
F	0.88		0.95	0.035		0.037
G	1.57	1.7	1.83	0.062	0.067	0.072
G1	16.87	17	17.13	0.664	0.669	0.674
H1	19.6			0.772		
H2			20.2			0.795
L	21.5		22.3	0.846		0.878
L1	21.4		22.2	0.843		0.874
L2	17.4		18.1	0.685		0.713
L3	17.25	17.5	17.75	0.679	0.689	0.699
L4	10.3	10.7	10.9	0.406	0.421	0.429
L7	2.65		2.9	0.104		0.114
M	4.1	4.3	4.5	0.161	0.169	0.177
M1	4.88	5.08	5.3	0.192	0.200	0.209
S	1.9		2.6	0.075		0.102
S1	1.9		2.6	0.075		0.102
Dia. 1	3.65		3.85	0.144		0.152

MUL11V.TBL

Information furnished is believed to be accurate and reliable. However, SGS-THOMSON Microelectronics assumes no responsibility for the consequences of use of such information nor for any infringement of patents or other rights of third parties which may result from its use. No licence is granted by implication or otherwise under any patent or patent rights of SGS-THOMSON Microelectronics. Specifications mentioned in this publication are subject to change without notice. This publication supersedes and replaces all information previously supplied. SGS-THOMSON Microelectronics products are not authorized for use as critical components in life support devices or systems without express written approval of SGS-THOMSON Microelectronics.

© 1994 SGS-THOMSON Microelectronics - All Rights Reserved

Purchase of I²C Components of SGS-THOMSON Microelectronics, conveys a license under the Philips I²C Patent. Rights to use these components in a I²C system, is granted provided that the system conforms to the I²C Standard Specifications as defined by Philips.

SGS-THOMSON Microelectronics GROUP OF COMPANIES

Australia - Brazil - China - France - Germany - Hong Kong - Italy - Japan - Korea - Malaysia - Malta - Morocco
The Netherlands - Singapore - Spain - Sweden - Switzerland - Taiwan - Thailand - United Kingdom - U.S.A.