



# TDA7401

## DIGITALLY CONTROLLED AUDIO PROCESSOR WITH LOUDSPEAKERS EQUALIZER

- FOUR HIGH PASS CHANNELS
- ONE STEREO LOW PASS CHANNEL WITH GAIN CONTROL
- DIRECT MUTE PIN
- FULLY PROGRAMMABLE VIA I<sup>2</sup>C BUS

### DESCRIPTION

The TDA7401 is an upgrade of the TDA7435 audioprocessor.

Due to a highly linear signal processing, using CMOS-switching techniques very low distortion and very low noise are obtained.

Second order high pass and low pass filters with programmable corner frequencies provide the loudspeaker equalization.

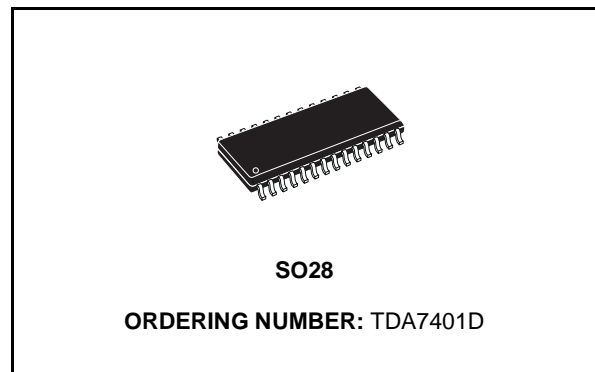

Very low DC stepping is obtained by using a BICMOS technology.

### BLOCK DIAGRAM

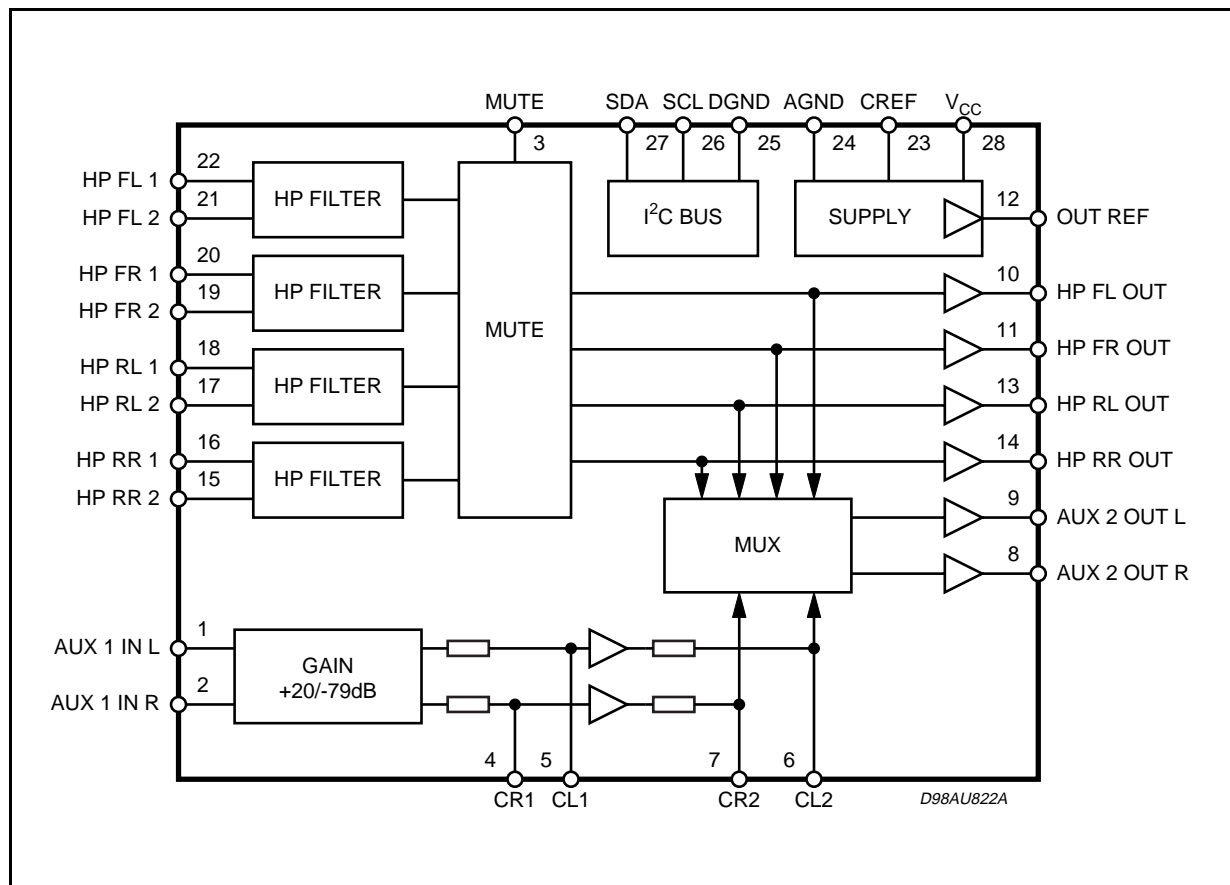

**ABSOLUTE MAXIMUM RATINGS**

Symbol	Parameter	Value	Unit
V <sub>S</sub>	Operating Supply Voltage	10.5	V
T <sub>amb</sub>	Operating Ambient Temperature	-40 to 85	°C
T <sub>stg</sub>	Storage Temperature Range	-55 to 150	°C

**PIN CONNECTION**

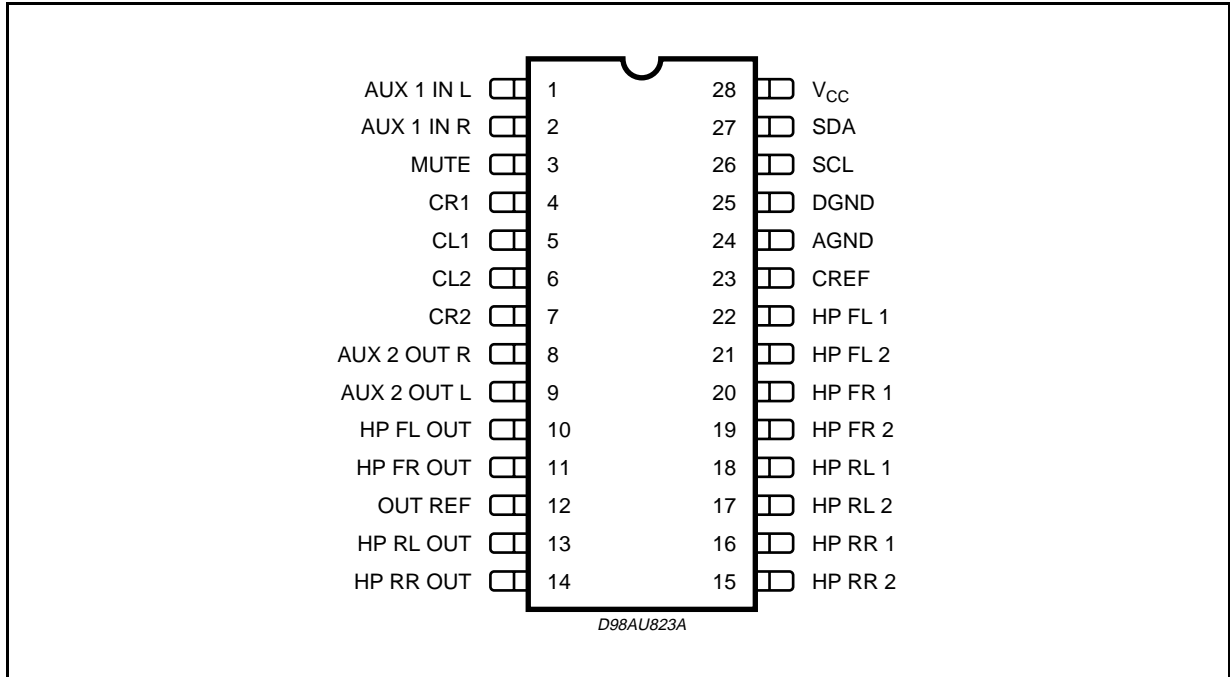

**THERMAL DATA**

Symbol	Parameter	Value	Unit
R <sub>th j-amb</sub>	Thermal Resistance Junction-pins	65	°C/W

**QUICK REFERENCE DATA**

Symbol	Parameter	Min.	Typ.	Max.	Unit
V <sub>S</sub>	Supply Voltage	6	9	10.2	V
V <sub>CL</sub>	Max. input signal handling	2.1	2.6		V <sub>rms</sub>
THD	Total Harmonic Distortion V = 1V <sub>rms</sub> f = 1KHz		0.01	0.08	%
S/N	Signal to Noise Ratio		106		dB
S <sub>C</sub>	Channel Separation f = 1KHz	-80	100		dB
V <sub>REF</sub>	Reference Voltage Output (pin 12)	4.2	4.5	4.8	V

**ELECTRICAL CHARACTERISTICS** ( $V_S = 9V$ ;  $R_L = 10K\Omega$ ;  $R_G = 50\Omega$ ;  $T_{amb} = 25^\circ C$ ; all gains = 0dB;  $f = 1KHz$ . Refer to the test circuit, unless otherwise specified.)

Symbol	Parameter	Test Condition	Min.	Typ.	Max.	Unit
<b>INPUT STAGE: AUX1</b>						
$R_I$	Input Resistance		37.5	50	62.5	$K\Omega$
$V_{CL}$	Clipping Level	$d \leq 0.3\%$	2.1	2.6		$V_{RMS}$
$S_I$	Input Separation		80	100		dB

**GAIN CONTROL**

$G_{MAX}$	Maximum Input Gain			20		dB
$A_{MAX}$	Maximum Attenuation			79		dB
$A_{STEP}$	Step Resolution		0.5	1	1.5	dB
$E_A$	Attenuation Set Error	$G = -20$ to $+20$ dB	-1.25	0	+1.25	dB
		$G = -60$ to $-20$ dB	-4		3	dB
$E_T$	Tracking Error				2	dB
$V_{DC}$	DC Steps	Adjacent Attenuation Steps		0.1	3	mV
		From 0dB to $G_{MIN}$		0.5	5	mV

**AUDIO OUTPUT (Pin 8 - 9, 10 - 14)**

$V_{clip}$	Clipping Level	$d = 0.3\%$	2.1	2.6		$V_{rms}$
$R_L$	Output Load Resistance	AC coupled	2			$K\Omega$
$R_O$	Output Impedance			30	100	$\Omega$
$V_{DC}$	DC Voltage Level		4.2	4.5	4.8	V

**STAGE: HP FILTER**

$R_1$	Resistance at pin HP1	HIGHPASS BYTE = XXXX1000	127.5	170	212.5	$K\Omega$
$R_2$	Resistance at pin HP2		1			$M\Omega$
$V_{CL}$	Clipping Level	$d \leq 0.3\%$	2.1	2.6		$V_{rms}$

**MUTE**

$A_{MUTE}$	Mute Attenuation		80	100		dB
$V_{THM}$	Mute Threshold		1.2	1.7	2.2	V
$R_{INT}$	Pullup Resistor (pin 3)	(note 1)	37.5	50	62.5	$K\Omega$

**GENERAL**

$V_{CC}$	Supply Voltage		6	9	10.2	V
$I_{CC}$	Supply Current		7	8	9	mA
PSRR	Power Supply Rejection Ratio	$f = 1KHz$	60	70		dB
$e_{NO}$	Output Noise	Non Inverting Output Muted (B = 20 to 20kHz flat)		3.5	15	$\mu V$
		All Gains 0dB (B = 20 to 20kHz flat)		5	15	$\mu V$
S/N	Signal to Noise Ratio	All Gains = 0dB; $V_O = 1V_{rms}$		106		dB
$S_C$	Channel Separation		80	100		dB
d	Distortion	$V_{IN} = 1V$		0.01	0.08	%

**BUS INPUTS**

$V_{IL}$	Input Low Voltage				0.8	V
$V_{IH}$	Input High Voltage		2.5			V
$I_{IN}$	Input Current	$V_{IN} = 0.4V$	-5		5	$\mu A$
$V_O$	Output Voltage SDA Acknowledge	$I_O = 1.6mA$	0.1		0.4	V

Note 1: Internal pullup resistor to 3.3V; "LOW" = mute active

Figure 1. HP Filter

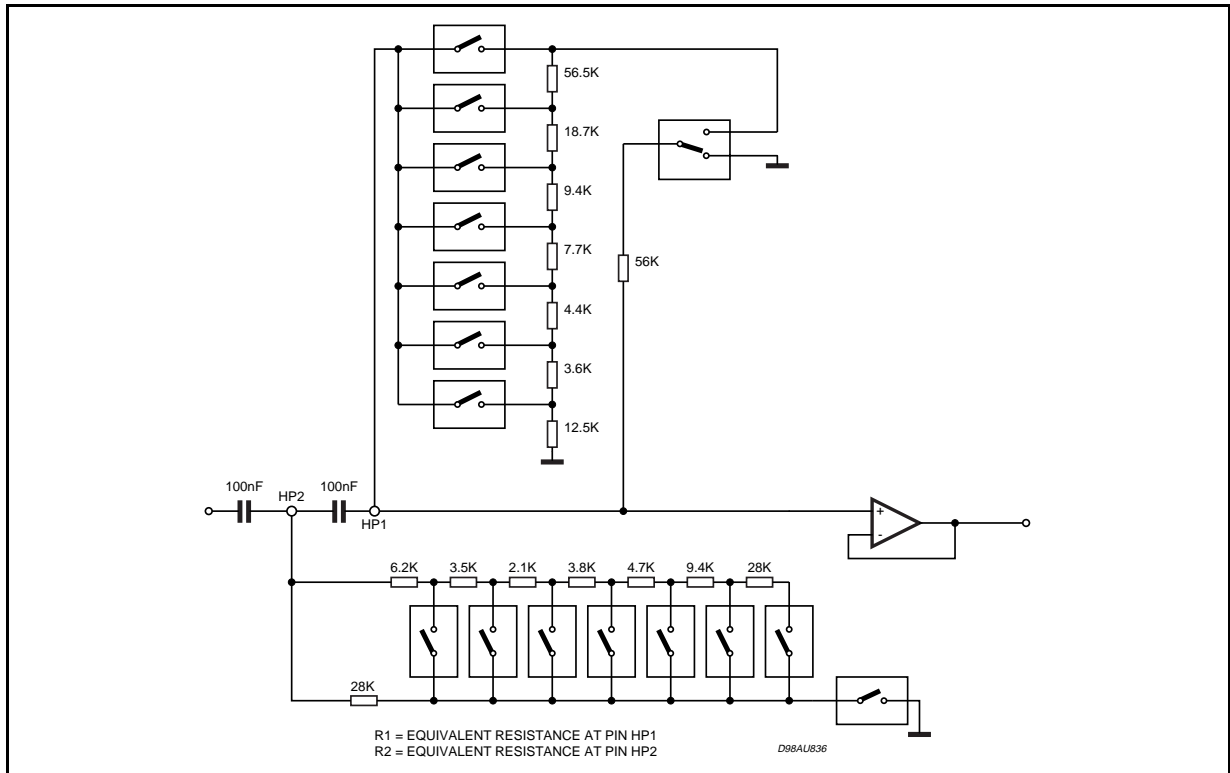
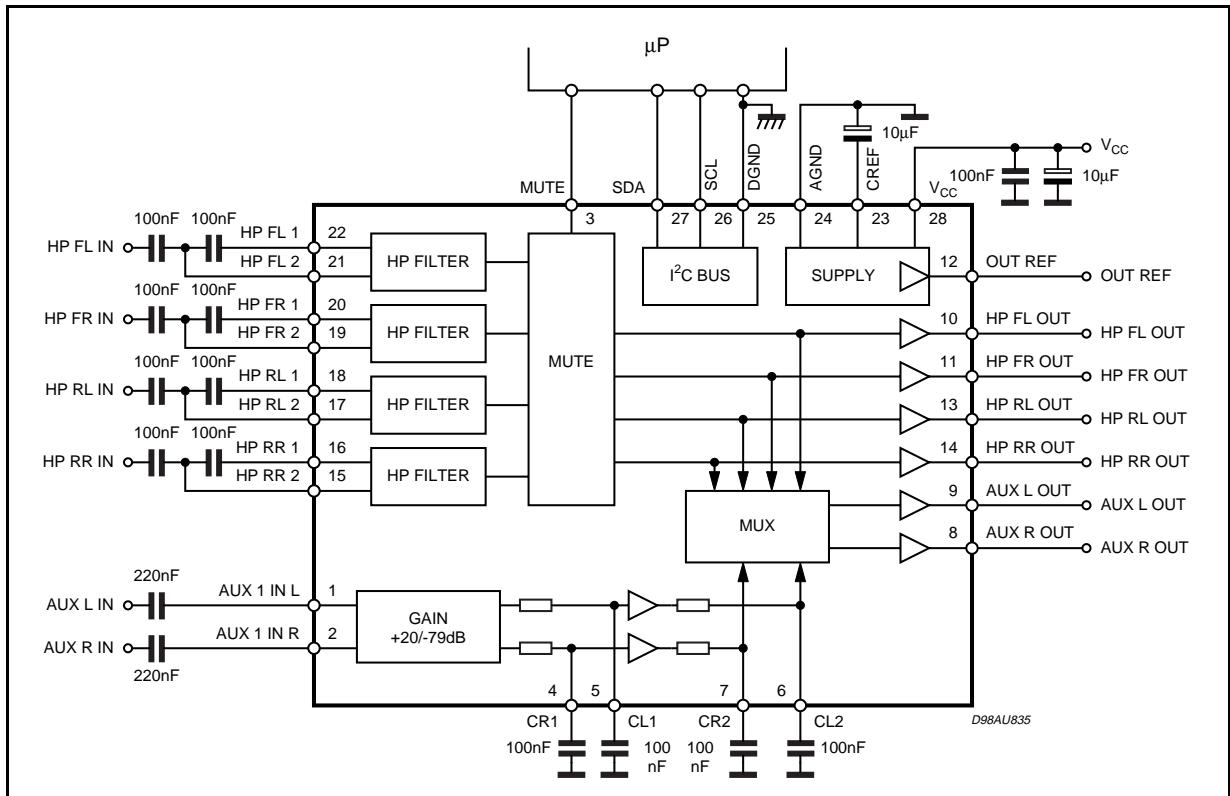

Figure 2. Application Circuit



### I<sup>2</sup>C BUS INTERFACE

Data transmission from microprocessor to the TDA7401 and viceversa takes place thru the 2 wires I<sup>2</sup>C BUS interface, consisting of the two lines SDA and SCL (pull-up resistors to positive supply voltage must be externally connected).

#### Data Validity

As shown in fig. 2, the data on the SDA line must be stable during the high period of the clock. The HIGH and LOW state of the data line can only change when the clock signal on the SCL line is LOW.

#### Start and Stop Conditions

As shown in fig.3 a start condition is a HIGH to LOW transition of the SDA line while SCL is HIGH. The stop condition is a LOW to HIGH transition of the SDA line while SCL is HIGH. A STOP conditions must be sent before each START condition.

#### Byte Format

Every byte transferred to the SDA line must con-

tain 8 bits. Each byte must be followed by an acknowledge bit. The MSB is transferred first.

#### Acknowledge

The master ( $\mu$ P) puts a resistive HIGH level on the SDA line during the acknowledge clock pulse (see fig. 4). The peripheral (audioprocessor) that acknowledges has to pull-down (LOW) the SDA line during the acknowledge clock pulse, so that the SDA line is stable LOW during this clock pulse.

The audioprocessor which has been addressed has to generate an acknowledge after the reception of each byte, otherwise the SDA line remains at the HIGH level during the ninth clock pulse time. In this case the master transmitter can generate the STOP information in order to abort the transfer.

#### Transmission without Acknowledge

Avoiding to detect the acknowledge of the audioprocessor, the  $\mu$ P can use a simpler transmission: simply it waits one clock without checking the slave acknowledging, and sends the new data.

This approach of course is less protected from misworking and decreases the noise immunity.

Figure 3. Data Validity on the I<sup>2</sup>C BUS

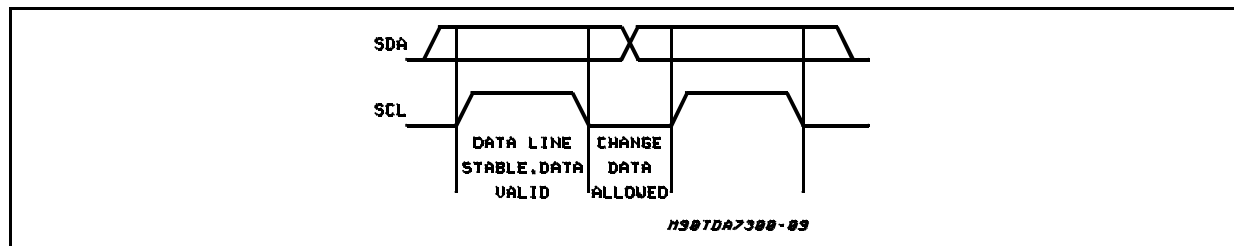

Figure 4. Timing Diagram of I<sup>2</sup>C BUS

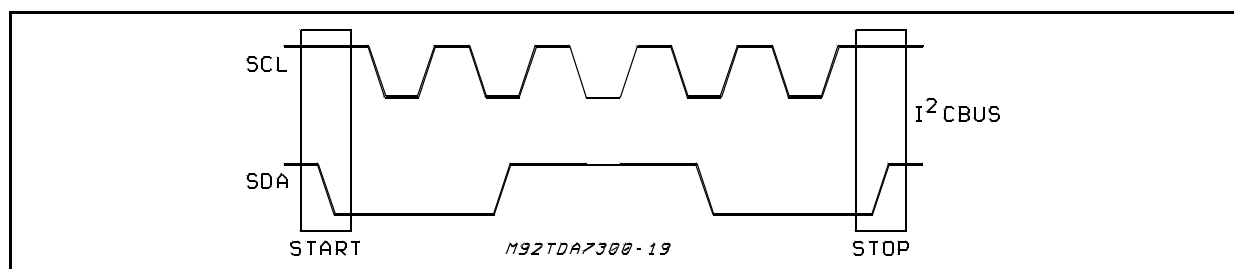
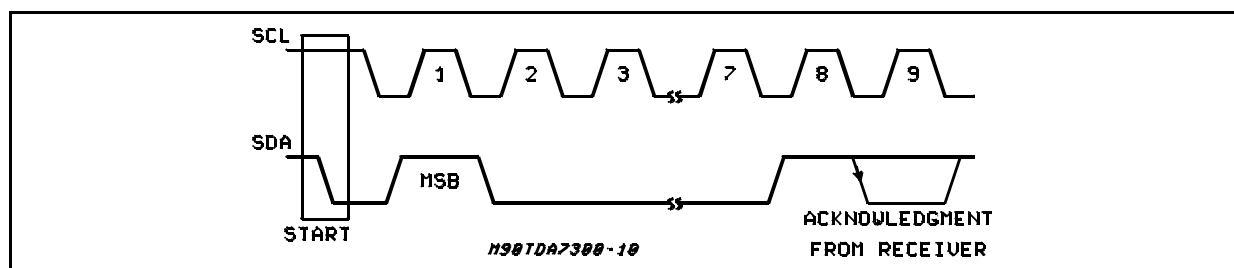

Figure 5. Acknowledge on the I<sup>2</sup>C BUS



**SOFTWARE SPECIFICATION**

**Interface Protocol**

The interface protocol comprises:

- A start condition (s)
- A chip address byte,(the LSB bit determines

read/write transmission)

- A subaddress byte.
- A sequence of data (N-bytes + acknowledge)
- A stop condition (P)

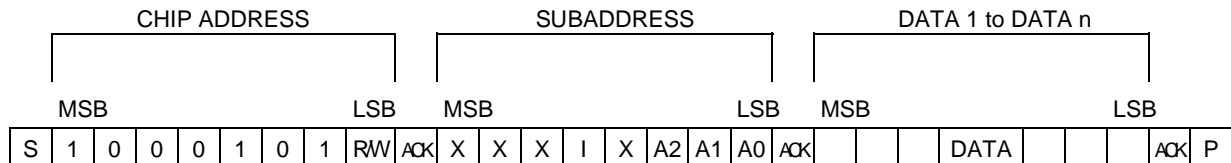

ACK = Acknowledge

S = Start

P = Stop

I = Auto Increment

X = Not used

**AUTO INCREMENT**

If bit I in the subaddress byte is set to "1", the autoincrement of the subaddress is enabled

**SUBADDRESS (receive mode)**

MSB					LSB			FUNCTION
X	X	X	I	X	D2	D1	D0	
					0	0	0	Not used
					0	0	1	Mode
					0	1	0	Gain AUX 1 L
					0	1	1	Gain AUX 1 R
					1	0	0	High Pass Filter FL
					1	0	1	High Pass Filter FR
					1	1	0	High Pass Filter RL
					1	1	1	High Pass Filter RR

## MODE

MSB							LSB		FUNCTION
D7	D6	D5	D4	D3	D2	D1	D0		
						0	X	High Pass Mute ON	
						1		High Pass Mute OFF	
					0			AUX1 Input Mute ON	
					1			AUX1 Input Mute OFF	
				0				AUX2 Inverted Output	
				1				AUX2 Non Inv. Output	
								<b>AUX 2 Output Selection</b>	
		0	0					High Pass Filter Front	
		0	1					High Pass Filter Rear	
		1	0					Aux 1 Input	
		1	1					Mute	
								AUX1 Low Pass Filter (C1 = C2 = 100nF)	
0	0							Flat	
0	1							120Hz	
1	0							80Hz	
1	1							50Hz	

## GAIN AUX1L, AUX1R

MSB							LSB		GAIN AUX1L, R
D7	D6	D5	D4	D3	D2	D1	D0		
1	0	0	1	1	1	1	1	+31dB	
:	:	:	:	:	:	:	:	:	
1	0	0	1	0	0	0	1	+17dB	
1	0	0	1	0	0	0	0	+16dB	
1	0	0	0	1	1	1	1	+15dB	
:	:	:	:	:	:	:	:	:	
1	0	0	0	0	0	0	1	+1dB	
1	0	0	0	0	0	0	0	0dB	
0	0	0	0	0	0	0	0	0dB	
0	0	0	0	0	0	0	1	-1dB	
:	:	:	:	:	:	:	:	:	
0	0	0	0	1	1	1	1	-15dB	
0	0	0	1	0	0	0	0	-16dB	
:	:	:	:	:	:	:	:	:	
0	1	0	0	1	1	1	0	-78dB	
0	1	0	0	1	1	1	1	-79dB	
X	1	1	X	X	X	X	X	Mute	

**Note:** Is is not recommended to use a gain more than 20dB for system performance reason. In general, the max. gain should be limited by software to the maximum value, which is needed for the system.

## HIGH PASS FILTERS

MSB							LSB		FL, FR, RL, RR
D7	D6	D5	D4	D3	D2	D1	D0		
								<b>2nd order HP Filter Mode (C1 = C2 = 100nF)</b>	
X	X	X	X	0	0	0	0	$f_c = 40\text{Hz}$	
				0	0	0	1	$f_c = 60\text{Hz}$	
				0	0	1	0	$f_c = 80\text{Hz}$	
				0	0	1	1	$f_c = 100\text{Hz}$	
				0	1	0	0	$f_c = 120\text{Hz}$	
				0	1	0	1	$f_c = 150\text{Hz}$	
				0	1	1	0	$f_c = 180\text{Hz}$	
				0	1	1	1	$f_c = 220\text{Hz}$	
								<b>First order HP Flat Mode</b>	
				1	0	0	0	$f_c = 9\text{Hz}$	



DIM.	mm			inch		
	MIN.	TYP.	MAX.	MIN.	TYP.	MAX.
A			2.65			0.104
a1	0.1		0.3	0.004		0.012
b	0.35		0.49	0.014		0.019
b1	0.23		0.32	0.009		0.013
C		0.5			0.020	
c1	45° (typ.)					
D	17.7		18.1	0.697		0.713
E	10		10.65	0.394		0.419
e		1.27			0.050	
e3		16.51			0.65	
F	7.4		7.6	0.291		0.299
L	0.4		1.27	0.016		0.050
S	8° (max.)					

### OUTLINE AND MECHANICAL DATA

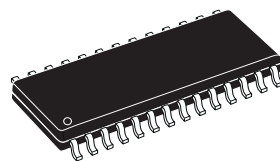

**SO28**

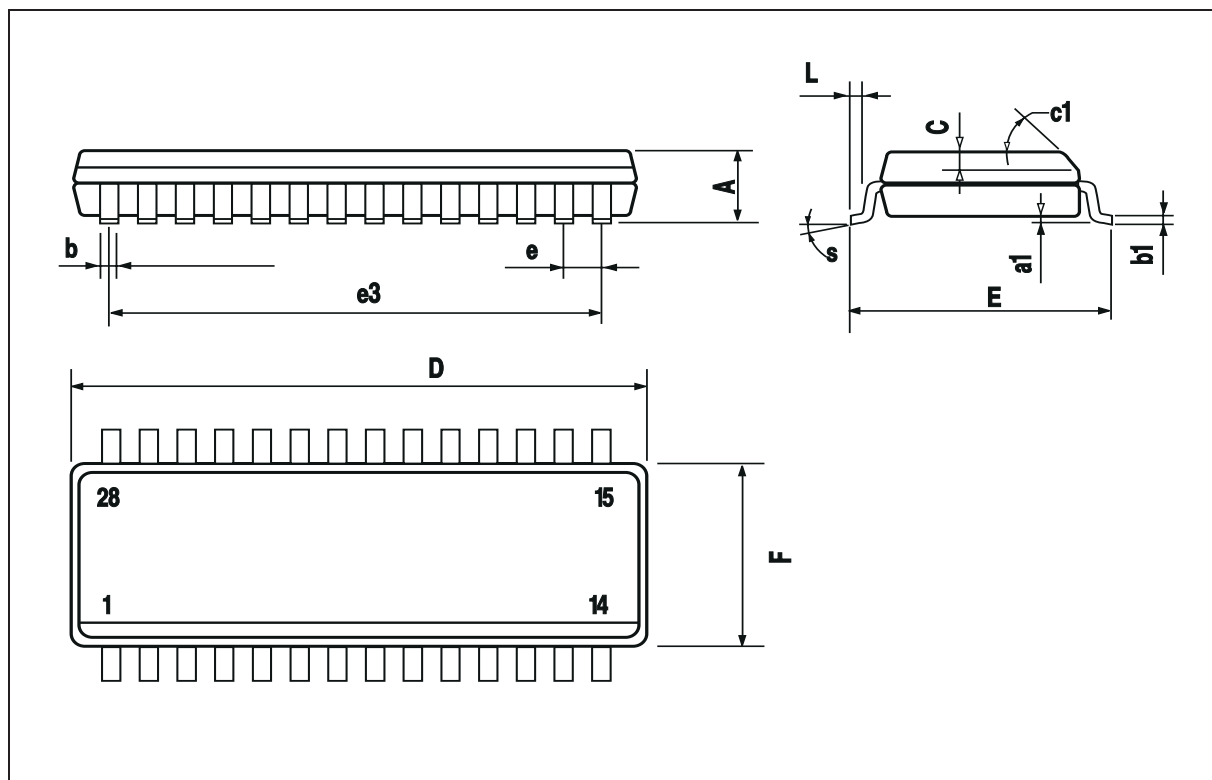

Information furnished is believed to be accurate and reliable. However, STMicroelectronics assumes no responsibility for the consequences of use of such information nor for any infringement of patents or other rights of third parties which may result from its use. No license is granted by implication or otherwise under any patent or patent rights of STMicroelectronics. Specification mentioned in this publication are subject to change without notice. This publication supersedes and replaces all information previously supplied. STMicroelectronics products are not authorized for use as critical components in life support devices or systems without express written approval of STMicroelectronics.

The ST logo is a registered trademark of STMicroelectronics

© 1999 STMicroelectronics – Printed in Italy – All Rights Reserved

STMicroelectronics GROUP OF COMPANIES

Australia - Brazil - Canada - China - France - Germany - Italy - Japan - Korea - Malaysia - Malta - Mexico - Morocco - The Netherlands - Singapore - Spain - Sweden - Switzerland - Taiwan - Thailand - United Kingdom - U.S.A.

<http://www.st.com>