



TDA7454

4 x 35W HIGH EFFICIENCY QUAD BRIDGE CAR RADIO AMPLIFIER

PRELIMINARY DATA

- HIGH OUTPUT POWER CAPABILITY:
 - 4 x 40W/4Ω MAX.
 - 4 x 35W/4Ω EIAJ.
 - 4 x 25W/4Ω @14.4V, 1KHz, 10%
 - 4 x 60W/2Ω MAX.
- 2Ω DRIVING CAPABILITY
- DUAL MODE OPERATING EXTERNALLY PRESETTABLE: CONVENTIONAL CLASS A-B MODE, HIGH EFFICIENCY MODE
- LOW EXTERNAL COMPONENTS COUNT:
 - NO BOOTSTRAP CAPACITORS
 - NO EXTERNAL COMPENSATION
 - INTERNALLY FIXED GAIN (26dB)
- CLIPPING DETECTOR
- ST-BY FUNCTION (CMOS COMPATIBLE)
- MUTE FUNCTION (CMOS COMPATIBLE)
- AUTOMUTE AT MINIMUM SUPPLY VOLTAGE DETECTION
- LOW RADIATION

Protections:

- OUTPUT SHORT CIRCUIT TO GND; TO V_S; ACROSS THE LOAD
- 3 STEPS OVERRATING CHIP TEMPERATURE WITH THERMAL WARNING
- LOAD DUMP VOLTAGE
- FORTUITOUS OPEN GND

BLOCK & APPLICATION DIAGRAM

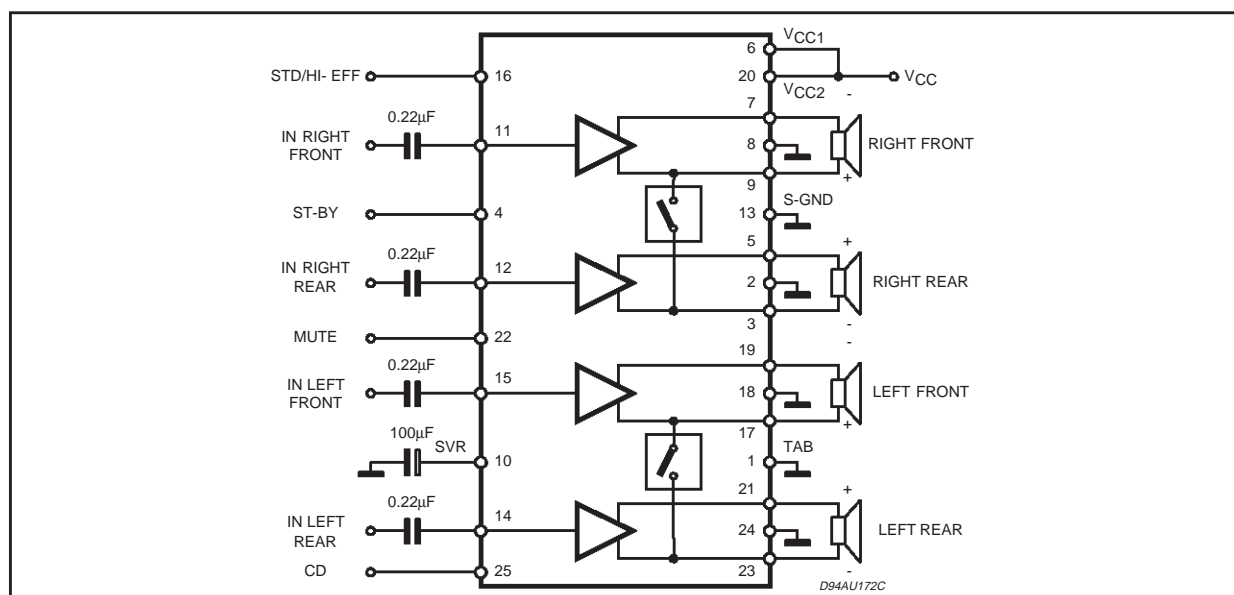

MULTIPOWER BCD TECHNOLOGY

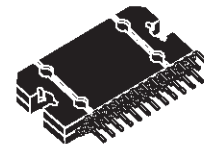

Flexiwatt 25

- LOUDSPEAKER DC CURRENT
- ESD

DESCRIPTION

The TDA7454 is a new BCD technology QUAD BRIDGE type of car radio amplifier in Flexiwatt25 package specially intended for car radio applications. Among the features, its superior efficiency performance coming from the internal exclusive structure, makes it the most suitable device to simplify the thermal management in high power sets. The dissipated output power under average listening condition is in fact reduced up to 50% when compared to the level provided by conventional class AB solutions.

TDA7454

ABSOLUTE MAXIMUM RATINGS

Symbol	Parameter	Value	Unit
V_{op}	Operating Supply Voltage	18	V
V_S	DC Supply Voltage	28	V
V_{peak}	Peak Supply Voltage (for $t = 50ms$)	40	V
I_o	Output Peak Current (not repetitive $t = 100\mu s$)	8	A
I_o	Output Peak Current (repetitive $f > 10Hz$)	6	A
P_{tot}	Power Dissipation $T_{case} = 70^\circ C$	86	W
T_{stg}, T_j	Storage and Junction Temperature	-55 to 150	$^\circ C$

THERMAL DATA

Symbol	Description	Value	Unit
$R_{th\ j-case}$	Thermal Resistance Junction-case	Max 1	$^\circ C/W$

PIN CONNECTION (Top view)

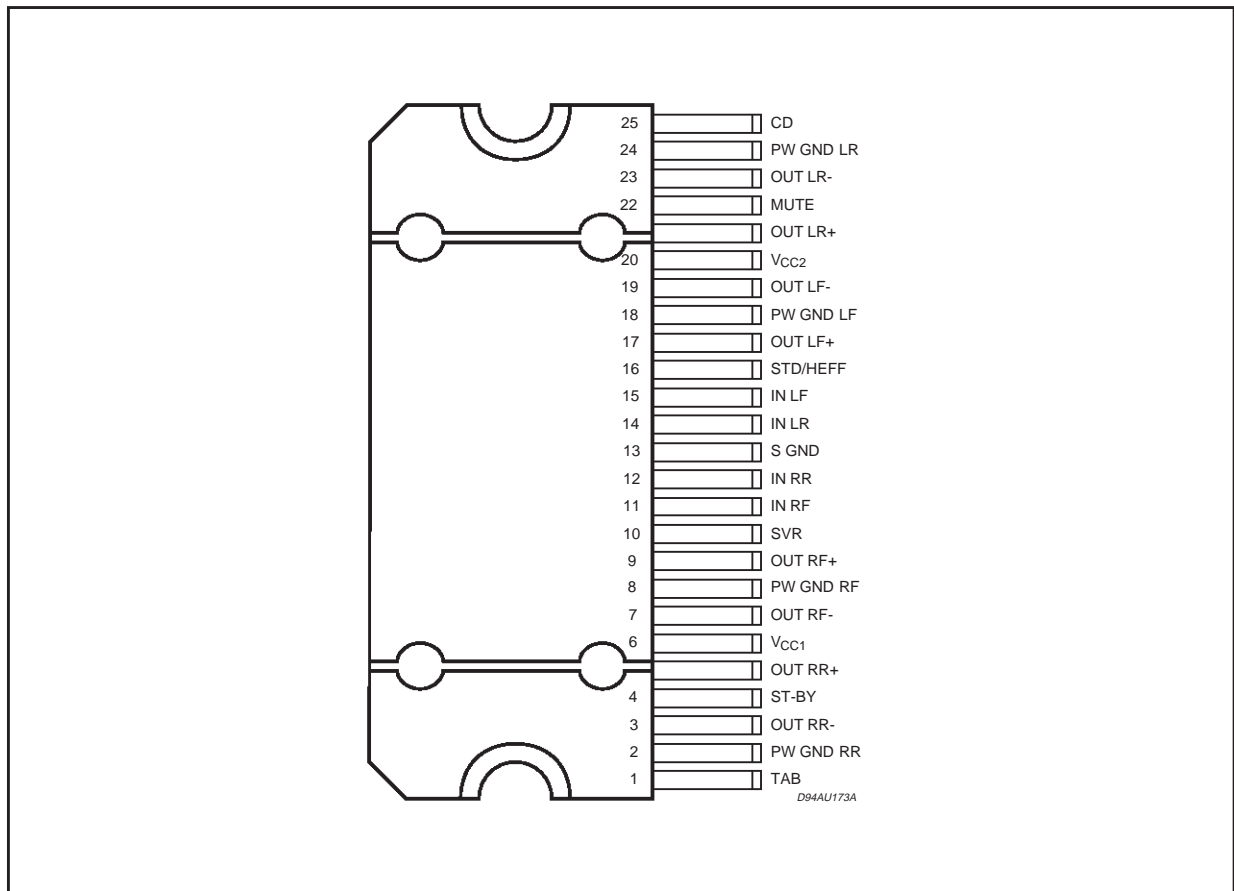

ELECTRICAL CHARACTERISTICS (Refer to the test circuit $V_S = 14.4V$; $R_L = 4\Omega$; $f = 1KHz$;
 $T_{amb} = 25^\circ C$, unless otherwise specified)

Symbol	Parameter	Test Condition	Min.	Typ.	Max.	Unit
V_S	Supply Voltage Range		8		18	V
I_d	Total Quiescent Drain Current		60	140	250	mA
P_o	Output Power	THD = 10%	23	25		W
		THD = 1%	18	20		W
P_o		THD = 10% $R_L = 2\Omega$;	40	42		W
		THD = 1% $R_L = 2\Omega$;	28	30		W
P_o EIAJ	EIAJ Output Power (*)	$V_S = 13.7V$	32	35		W
		$V_S = 13.7V$, $R_L = 2\Omega$	50	52		W
P_o max.	Max. Output Power (*)	$V_S = 14.4V$	38	40		W
		$V_S = 14.4V$, $R_L = 2\Omega$	55	60		W
THD	Total harmonic distortion	$P_o = 1W$ to $10W$; STD MODE		0.03	0.3	%
		$P_o = 1W$; HE MODE		0.04	0.3	%
		$P_o = 10W$; HE MODE		0.1	0.5	%
		$R_L = 2\Omega$; HE MODE; $P_o = 3W$		0.06	0.3	%
		$R_L = 2\Omega$; HE MODE; $P_o = 15W$		0.15	0.5	%
C_T	Cross Talk	$f = 1KHz$ to $10KHz$	45	55		dB
R_{IN}	Input Impedance		11	15	19	$K\Omega$
G_V	Voltage Gain		25	26	27	dB
ΔG_V	Voltage Gain Match				1	dB
E_{IN}	Output Noise Voltage	$R_g = 600\Omega$		100	150	mV
SVR	Supply Voltage Rejection	$f = 300Hz$; $V_r = 1V_{rms}$; $R_g = 0$ to 100Ω ;	45	52		dB
BW	Power Bandwidth	(-3dB)	75			KHz
A_{SB}	Stand-by Attenuation		90	100		dB
$V_{sb IN}$	Stand-by in Threshold				1.5	V
$V_{sb OUT}$	Stand-by out Threshold		3.5			V
I_{sb}	Stand-by Current Consumption				100	μA
A_M	Mute Attenuation		80	90		dB
$V_{M IN}$	Mute in Thershold				1.5	V
$V_{M OUT}$	Mute out Threshold		3.5			V
I_M	Mute pin Current (Sourced)	$V = 0$ to V_S $V_{S max} = 18V$	-10	1	10	μA
	Mode Select Switch	Standard BTL Mode Op. ($V_{pin 16}$)	Open			
		High Efficiency Mode ($V_{pin 16}$)			0.5	V
CD	Clip Det. out Current (Pull up to 5V with $10K\Omega$)	CD off: $P_{Omin} = 10W$ CD on: THD = 5%		150	5	μA μA

(*) Saturated square wave output.

TDA7454

Figure 1: Standard Test and Application Circuit.

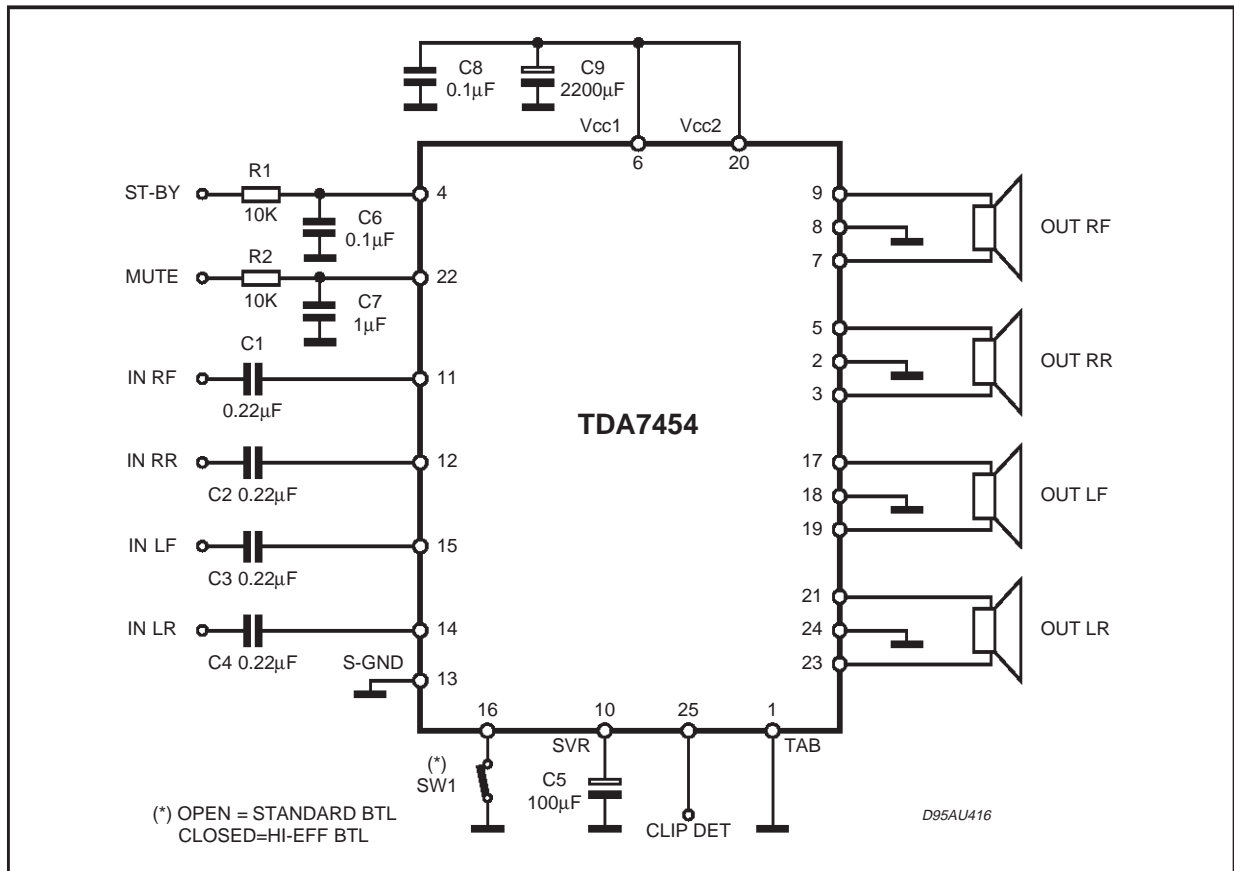

Figure 2: P.C.B. and components layout of fig. 1 circuit. (1.25 :1 scale)

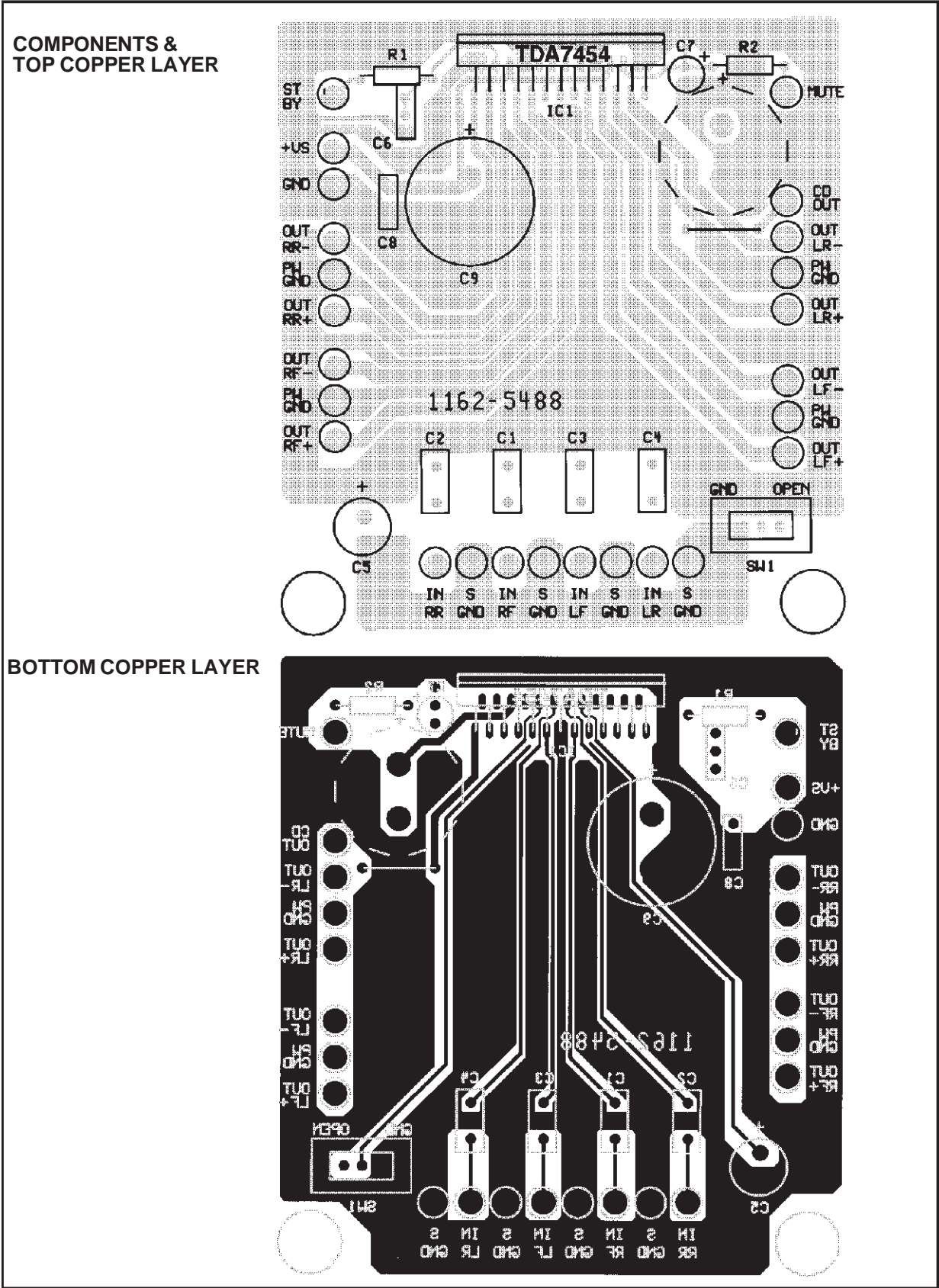

Figure 3: Quiescent Current vs. Supply Voltage

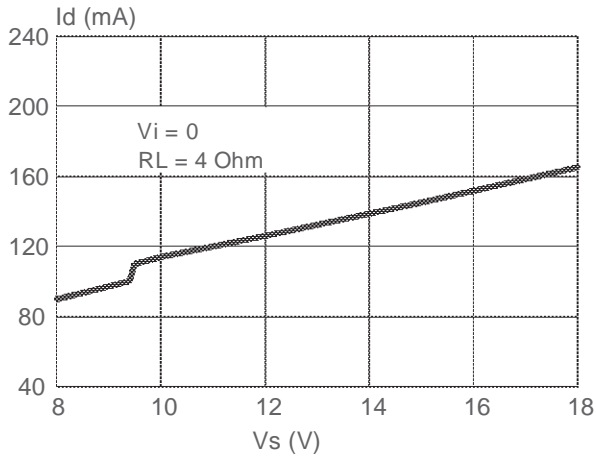

Figure 4: Output Power vs. Supply Voltage

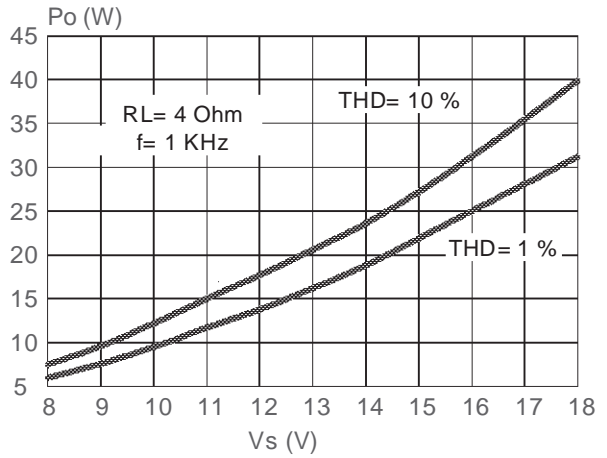

Figure 5: Max. Output Power vs. Supply Voltage

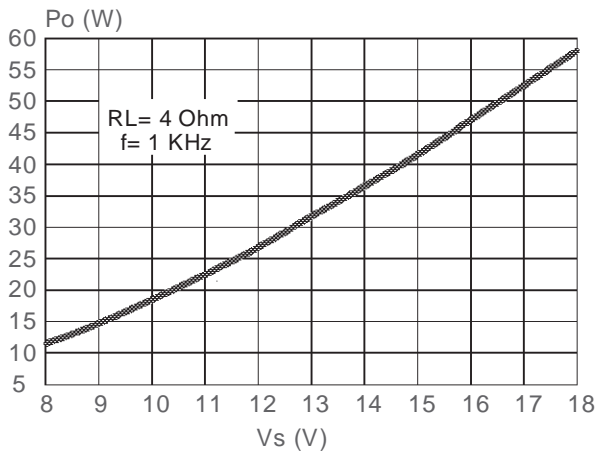

Figure 6: Output Power vs. Supply Voltage

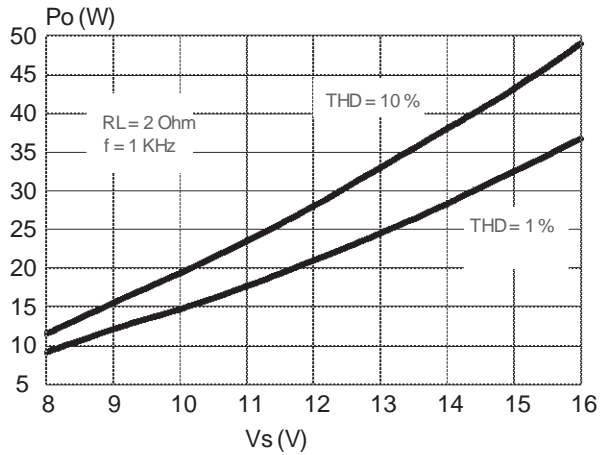

Figure 7: Max. Output Power vs. Supply Voltage

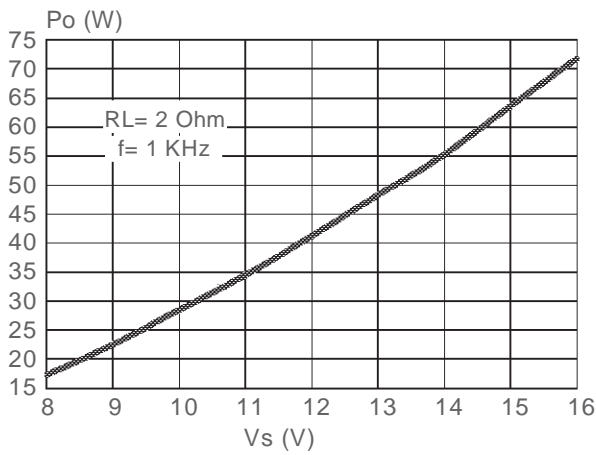

Figure 8: THD vs. Output Power

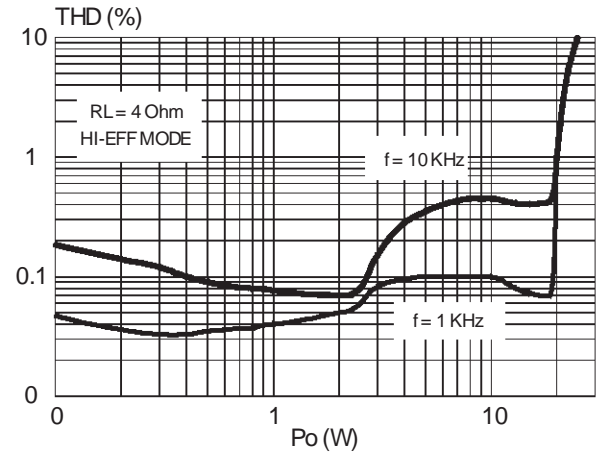

Figure 9: THD vs. Output Power

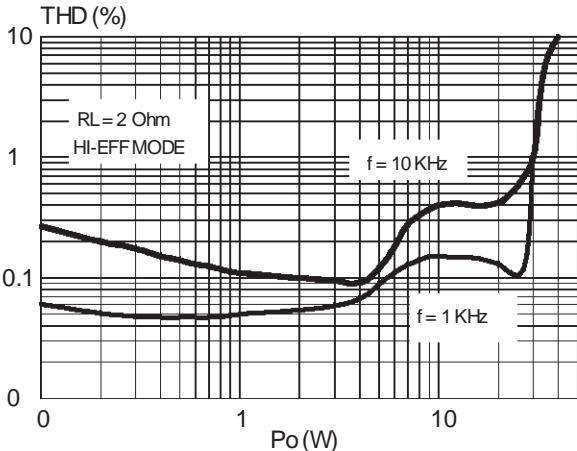

Figure 10: Muting Attenuation vs. Vpin 22

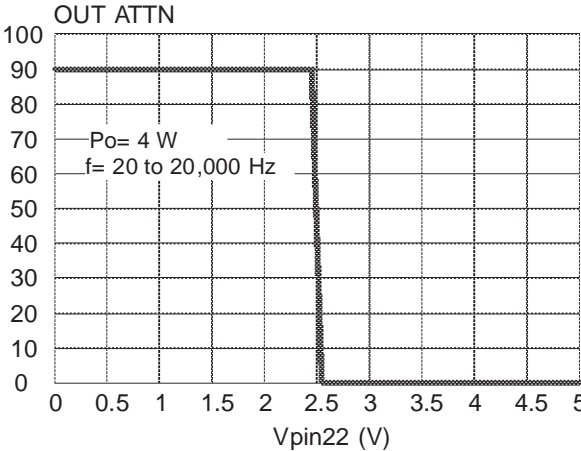

Figure 11: THD vs. Frequency

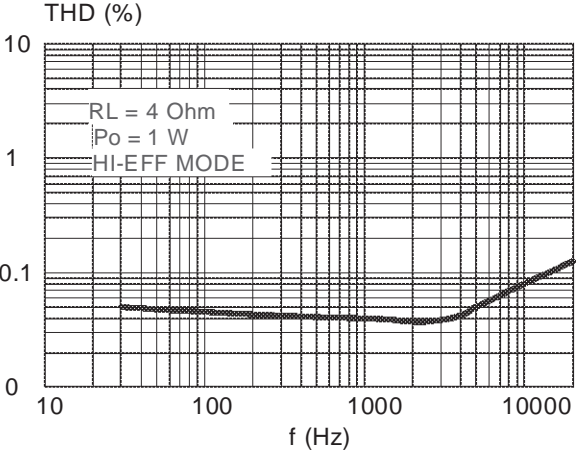

Figure 12: Supply Voltage Rejection vs. Frequency

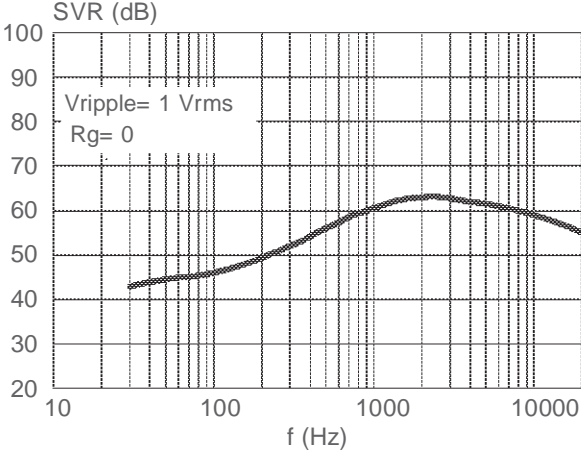

Figure 13: Cross-Talk vs. Frequency

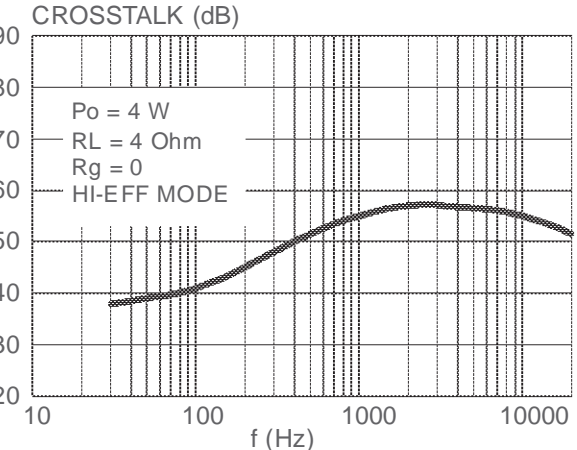
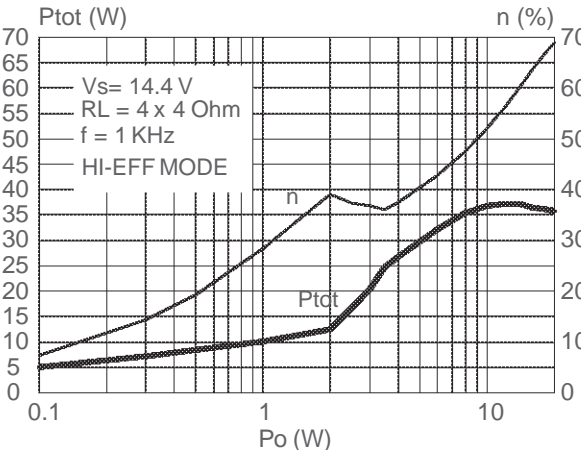

Figure 14: Power Dissipation and Efficiency vs. Output Power



OPERATING PRINCIPLE.

Thanks to its unique operating principle, the TDA7454 obtains a substantial reduction of power dissipation from traditional class-AB amplifiers without being affected by the massive radiation effects and complex circuitry normally associated with class-D solutions.

Its is composed of 8 amplifier blocks, making up 4 bridge-equivalent channels. Half of this structure is drafted in fig 15. These blocks continuously change their connections during every single signal event, according to the instantaneous power demand. This means that at low volumes (output power steadily lower than 2.5 W) the TDA7454 acts as a Single Ended amplifier, condition where block "C" remains disabled and the block "D" behaves like a buffer, which, by furnishing the correct DC biasing (half-Vcc) to each pair of speakers, eliminate the needs of otherwise required output-decoupling capacitors. At the same time, SW1 keeps closed, thus ensuring a common biasing point for L-R front / L-R rear speakers couples. As a result, the equivalent circuit becomes that of fig. 16.

The internal switches (SW1) are high-speed, dissipation-free power MOS types, whose realization has been made possible by the ST- exclusive By-polar-CMOS-DMOS mixed technology process (BCD). From fig. 16 it can be observed that "A" and "B" amplifiers work in phase opposition. Supposing their output have the same signal (equal shape/amplitude), the current sourced by "B" will be entirely sunk by "A", while no current will flow into "D", causing no power dissipation in the latter.

"A" and "B" are practically configured as a bridge whose load is constituted by $R_a + R_b$ (= 8 Ohm, if 4 Ohm speakers are used), with considerable advantages in terms of power dissipation. Designating "A" and "B" for the reproduction of either FRONT or REAR sections of the same channel (LEFT or RIGHT), keeping the fader in centre position (same amplitude for FRONT and REAR sections) and using the same speakers, as it happens during most of the time, will transpose this best-case dissipation condition into practical applications.

To fully take advantage of the TDA7454's low-dissipation feature, it is then especially important to adopt some criteria in the channels assignment, using the schematic of fig. 1 as a reference. When the power demand increases to more than 2.5 W, all the blocks will operate as amplifiers, SW1 is opened, leading to the seemingly conventional bridge configuration of fig. 17.

The efficiency enhancement is based upon the concept that the average output power during the reproduction of normal music/speech programs will stand anywhere between 10 % and 15 % of the rated power (@ THD= 10 %) that the amplifier

can deliver. This holds true even at high volumes and frequent clipping occurrence.

Applied to the TDA7454 (rated power= 25 W), this will result into an average output level of 2.5 - 3 W in sine-wave operation, region where the dissipated power is about 50 % less than that of a traditional amplifier of equivalent power class (see TDA7454 vs. CLASS-AB characteristics, fig. 18). Equally favourable is the case shown by fig. 19, when gaussian-distributed signal amplitudes, which best simulates the amplifier's real working conditions, are used.

APPLICATION HINTS (ref. to the circuit of fig. 1)

STAND-BY and MUTING (pins 4 & 22)

Both STAND-BY and MUTING pins are CMOS-compatible. The current sunk by each of them is about 1 μ A. For pop prevention it is essential that during TURN ON/OFF sequences the muting be preventively inserted before making stand-by transitions. But, if for any reason, either muting or stand-by are not used, they have to be connected to Vcc through a 100 Kohm (minimum) resistance.

The R-C networks values in fig. 1 (R1-C6 and R2-C7) are meant to be the minimum-necessary for obtaining the lowest pop levels possible. Any reductions (especially for R2-C7) will inevitably impair this parameter.

SVR (pin 10)

The duty of the SVR capacitor (C5) is double: assuring adequate supply-ripple rejection and controlling turn ON/OFF operations. Its indicated value (100 μ F) is the minimum-recommended to correctly serve both the purposes.

INPUTS (pins 11-12-13-14)

The inputs are internally biased at half-Vcc level. The typical input impedance is 15 KOhm, which implies using C_{in} (C1-C2-C3-C4) = 220 nF for obtaining a theoretical minimum-reproducible frequency of 48 Hz (-3 dB). In any case, C_{in} values can be enlarged if a lower frequency bound is desired, but, at any C_{in} enlargement must correspond a proportional increase of C_{svr} (C5), to safeguard the on/off pop aspect.

The following table indicates the right values to be used for C_{in} and C_{svr} , whose operating voltage can be 10 V.

LOW FREQUENCY ROLL-OFF (-3dB)	C_{in} (μ F)	C_{svr} (μ F)
48	0.22	100
22	0.47	220
16	0.68	330
11	1	470

Table 1: MODE SELECTION TABLE OPERATION OF THE DEVICE

1) STD/HI-EFF (pin 16 = OPEN)

STANDARD QUAD BRIDGE MODE	HIGH-EFF QUAD BRIDGE MODE	STANDARD QUAD SINGLE-ENDED MODE	ST-BY MODE	→ Tchip (deg)
100	150	170		

2) STD/HI-EFF (pin 16 = GND)

HIGH-EFF QUAD BRIDGE MODE	STANDARD QUAD SINGLE-ENDED MODE	ST-BY MODE	→ Tchip (deg)
150	170		

3) STD/HI-EFF (pin 16 connected as shown in the figure below.)

STANDARD QUAD BRIDGE MODE OR HIGH-EFF MODE (Theatsink dependent)	HIGH-EFF QUAD BRIDGE MODE	STANDARD QUAD SINGLE-ENDED MODE	ST-BY MODE	→ Tchip (deg)
100	150	170		

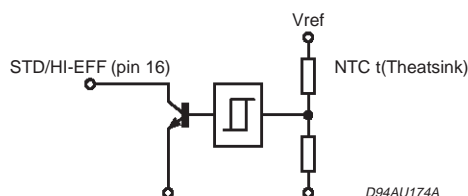

OUTPUT STAGE STABILITY

The TDA7454's is intrinsically stable and will properly drive any kind of conventional car-radio speakers without the need of supplementary output compensation (e.g. Boucherot cells), thus allowing a drastic reduction of the external parts whose number, abated to the essentials, reflects that of traditional amplifiers. In this respect, perfect pin-to-pin compatibility with the entire Sgs-Thomson's 4-BTL family (TDA738X) exists.

STANDARD / HIGH-EFFICIENCY OPERATION (pin 16)

The TDA7454's operating mode can be selected by changing the connection of pin 16, according to table 1.

At low battery levels (<10 V), the device will automatically turn into STANDARD BRIDGE mode, independently from the status of pin 16.

Condition # 3 in table 1 is particularly useful when the TDA7454's operation has to be conditioned by the temperature in other more heat-sensitive devices in the same environment. The NTC resistor is a temperature sensor, to be situated near the critical part(s), will appropriately drive pin 16 through a low-power transistor. Initially the

TDA7454 can be set to operate as a STANDARD BRIDGE, turning into HIGH EFFICIENCY mode only if overheating is recognised in the critical spot, thus reducing the overall temperature in the circuit.

CLIPPING DETECTOR / DIAGNOSTIC (pin 25)

The TDA7454 is equipped with a diagnostic function whose output is available at pin 25. This pin requires a pull-up resistor (10 KOhm min.) to a DC source that may range from 5 V to Vcc. The following events will be recognized and signaled out:

Clipping

A train of negative-going pulses will appear, each of them synchronized with every single clipping event taking place in ant of the outputs.

A possible application consists of filtering / integrating the pulses and implement a routine for automatically reducing / restoring the volume using microprocessor - driven audioprocessors, to counteract the clipping sound-damaging effects.

Overheating

Chip temperatures above 150 oC will be signaled out at pin 25 in the form of longer-lasting pulses, as the stepping back into the operating temperature requires some time.

This constitutes a substantial difference from the “clipping” situation, making the two information unmistakable. Associated to a suitable external circuitry, this “warning” signal could be used to mute some portions of the I.C. (e.g. the rear channels) or to attenuate the volume.

Short Circuit

Some kinds of short circuit (OUT - GND, OUT-Vcc), either present before the power-on or made afterwards, will cause pin 25 to remain steadily low as long as the faulty condition persists. Short-circuits across the speakers will give intermittent (pulsed) signalling, proportional to the output voltage amplitude.

External Layout Grounding

The 4 bridge structures have independent power ground accesses (pins 2,8,18,24), while the signal ground is common to all of them (pin 13). The

TAB (pin 1) is connected to the chip substrate and has to be grounded to the best-filtered ground spot (usually nearby the minus terminal of the Vcc-filtering electrolytic capacitor). This same point should be used as the centre of a multi-track star-like configuration, or, alternatively, as the origin of only two separate tracks, one for P-GND, one for S-GND, each of them routed to their specific ground pin(s).

This will provide the right degree of separation between P-GND and S-GND yet assuring the (necessary) electrical connection between them. The correct ground assignment for the each element of the circuit will then be:

POWER GND:

Battery (-), Supply filters (C8, C9), TAB (pin 1).

SIGNAL GND:

Pre-amplifier (Audiprocessor) ground, SVR capacitor (C5), muting/st-by capacitors (C6, C7).

Figure 15: TDA7454's Half Structure

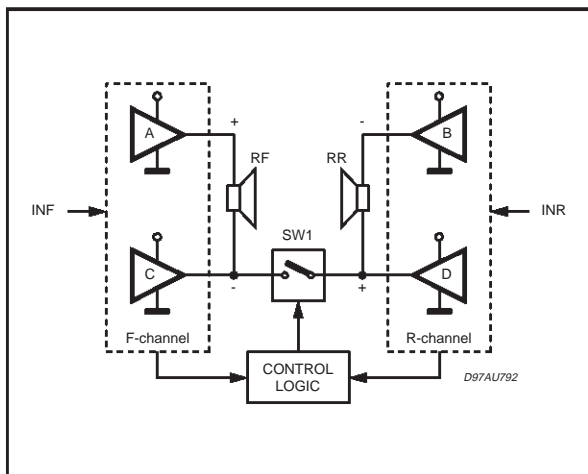

Figure 16: Single Ended Operation (Po < 2.5W)

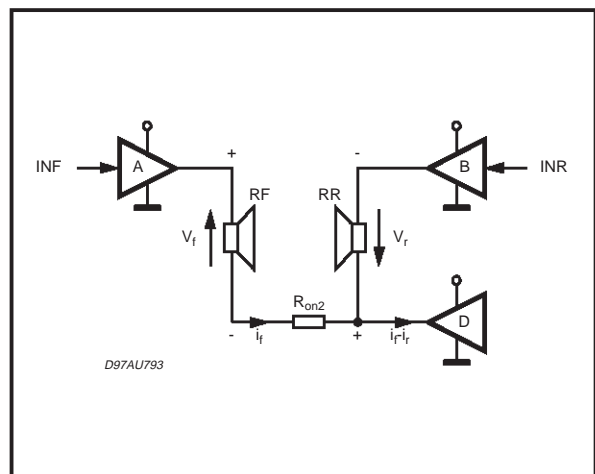

Figure 17: He Bridge Operation (Po < 2.5W)

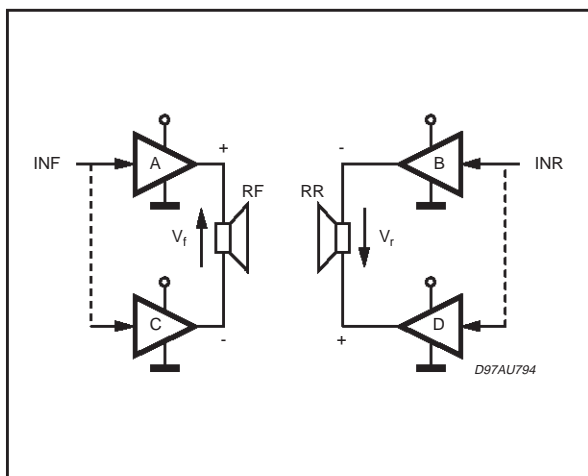

Figure 18: Power Dissipation (Sine-Wave)

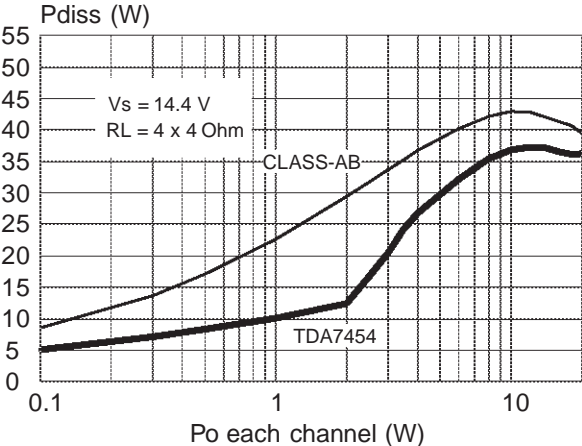
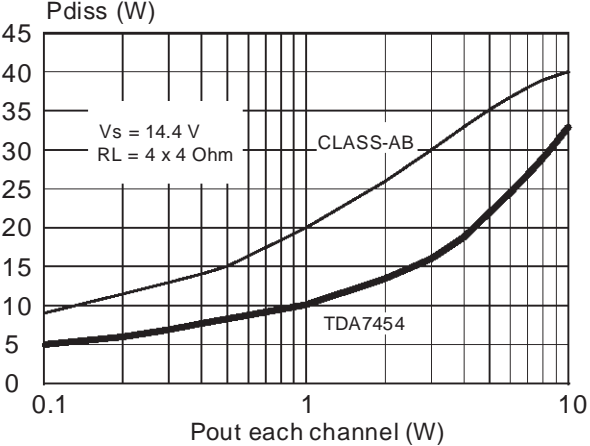
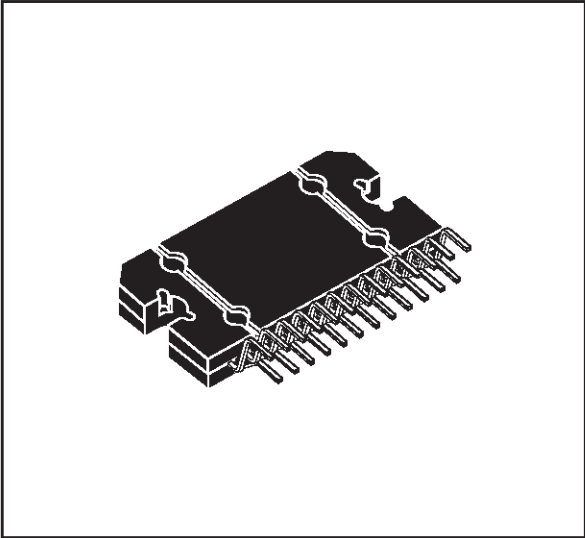

Figure 19: Power Dissipation (Gaussian Signals)



DIM.	mm			inch		
	MIN.	TYP.	MAX.	MIN.	TYP.	MAX.
A	4.45		4.65	0.175		0.183
B	1.80	1.90	2.00	0.070	0.074	0.079
C		1.40			0.055	
D	0.75	0.90	1.05	0.029	0.035	0.041
E	0.37	0.39	0.42	0.014	0.015	0.016
F			0.57			0.022
G	0.80	1.00	1.20	0.031	0.040	0.047
G1	23.75	24.00	24.25	0.935	0.945	0.955
H	28.90	29.23	29.30	1.138	1.150	1.153
H1		17.00			0.669	
H2		12.80			0.503	
H3		0.80			0.031	
L	21.57	21.97	22.37	0.849	0.865	0.880
L1	18.57	18.97	19.37	0.731	0.786	0.762
L2	15.50	15.70	15.90	0.610	0.618	0.626
L3	7.70	7.85	7.95	0.303	0.309	0.313
M	3.70	4.00	4.30	0.145	0.157	0.169
M1	3.60	4.00	4.40	0.142	0.157	0.173
N		2.20			0.086	
O		2			0.079	
R		1.70			0.067	
R4		0.50			0.019	
V2				20°		
V3				45°		

OUTLINE AND MECHANICAL DATA



Flexiwatt25

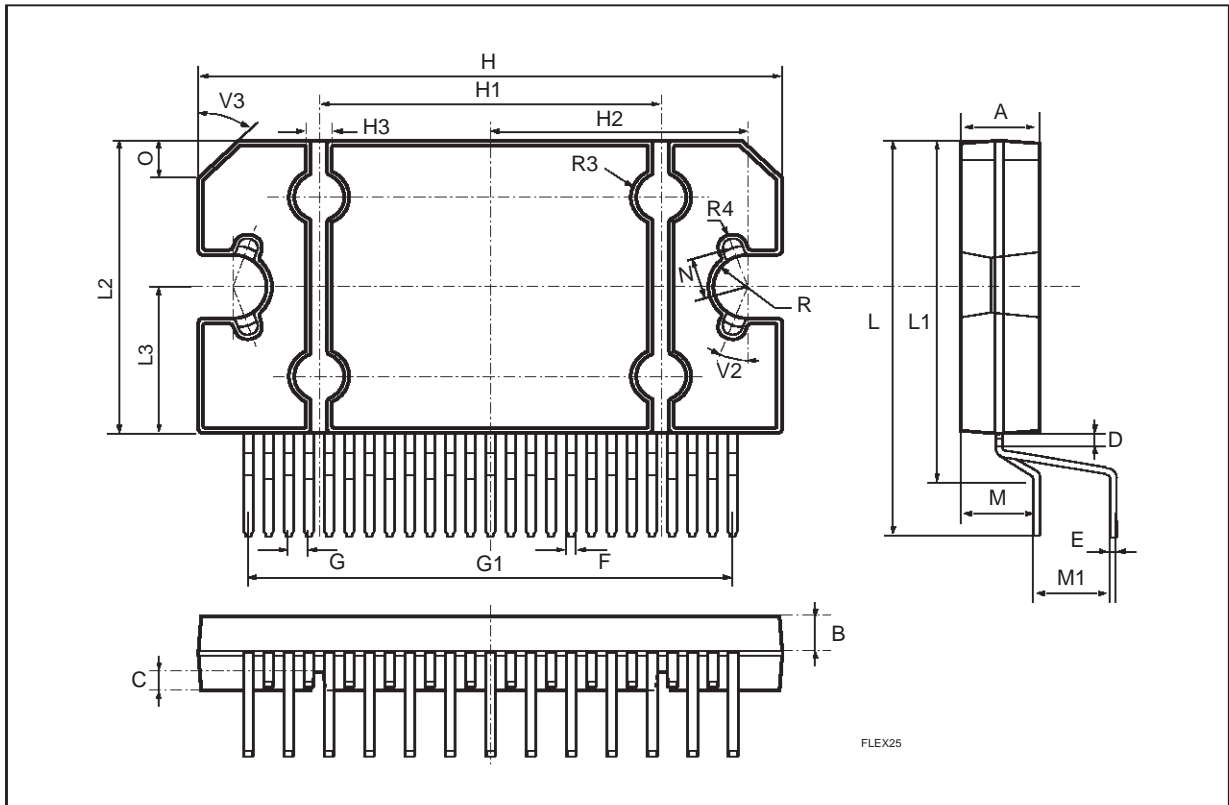

Information furnished is believed to be accurate and reliable. However, STMicroelectronics assumes no responsibility for the consequences of use of such information nor for any infringement of patents or other rights of third parties which may result from its use. No license is granted by implication or otherwise under any patent or patent rights of STMicroelectronics. Specification mentioned in this publication are subject to change without notice. This publication supersedes and replaces all information previously supplied. STMicroelectronics products are not authorized for use as critical components in life support devices or systems without express written approval of STMicroelectronics.

The ST logo is a registered trademark of STMicroelectronics

© 1998 STMicroelectronics – Printed in Italy – All Rights Reserved

STMicroelectronics GROUP OF COMPANIES

Australia - Brazil - Canada - China - France - Germany - Italy - Japan - Korea - Malaysia - Malta - Mexico - Morocco - The Netherlands - Singapore - Spain - Sweden - Switzerland - Taiwan - Thailand - United Kingdom - U.S.A.

<http://www.st.com>