

DATA SHEET

TDA8551

1 W BTL audio amplifier with digital volume control

Product specification
Supersedes data of 1997 May 07
File under Integrated Circuits, IC01

1998 Feb 23

1 W BTL audio amplifier with digital volume control**TDA8551****FEATURES**

- One pin digital volume control
- Volume setting with UP/DOWN pulses
- Flexibility in use
- Few external components
- Low saturation voltage of output stage
- standby mode controlled by CMOS compatible levels
- Low standby current
- No switch-on/switch-off plops
- High supply voltage ripple rejection
- Protected against electrostatic discharge
- Outputs short circuit safe to ground, V_P and across the load
- Thermally protected.

GENERAL DESCRIPTION

The TDA8551; TDA8551T is a one channel 1 W Bridge-Tied Load (BTL) audio power amplifier capable of delivering 1 W output power to an 8 Ω load at THD = 10% using a 5 V power supply. The circuit contains a BTL power amplifier, a digital volume control and standby/mute logic. The TDA8551T comes in an 8 pin SO package and the TDA8551 in a 8 pin DIP package.

APPLICATIONS

- Portable consumer products
- Personal computers
- Telephony.

QUICK REFERENCE DATA

SYMBOL	PARAMETER	CONDITIONS	MIN.	TYP.	MAX.	UNIT
V_P	supply voltage		2.7	5	5.5	V
I_q	quiescent current	$V_P = 5\text{ V}$	–	6	10	mA
I_{stb}	standby current		–	–	10	μA
P_o	output power	THD = 10%; $R_L = 8\ \Omega$; $V_P = 5\text{ V}$	1	1.4	–	W
G_v	voltage gain		–60	–	+20	dB
n_{vol}	number of volume steps		–	64	–	
THD	total harmonic distortion	$P_o = 0.5\text{ W}$	–	0.15	–	%
SVRR	supply voltage ripple rejection		48	–	–	dB

ORDERING INFORMATION

TYPE NUMBER	PACKAGE		
	NAME	DESCRIPTION	VERSION
TDA8551T	SO8	plastic small outline package; 8 leads; body width 3.9 mm	SOT96-1
TDA8551	DIP8	plastic dual in-line package; 8 leads (300 mil)	SOT97-1

1 W BTL audio amplifier with digital volume control

TDA8551

BLOCK DIAGRAM

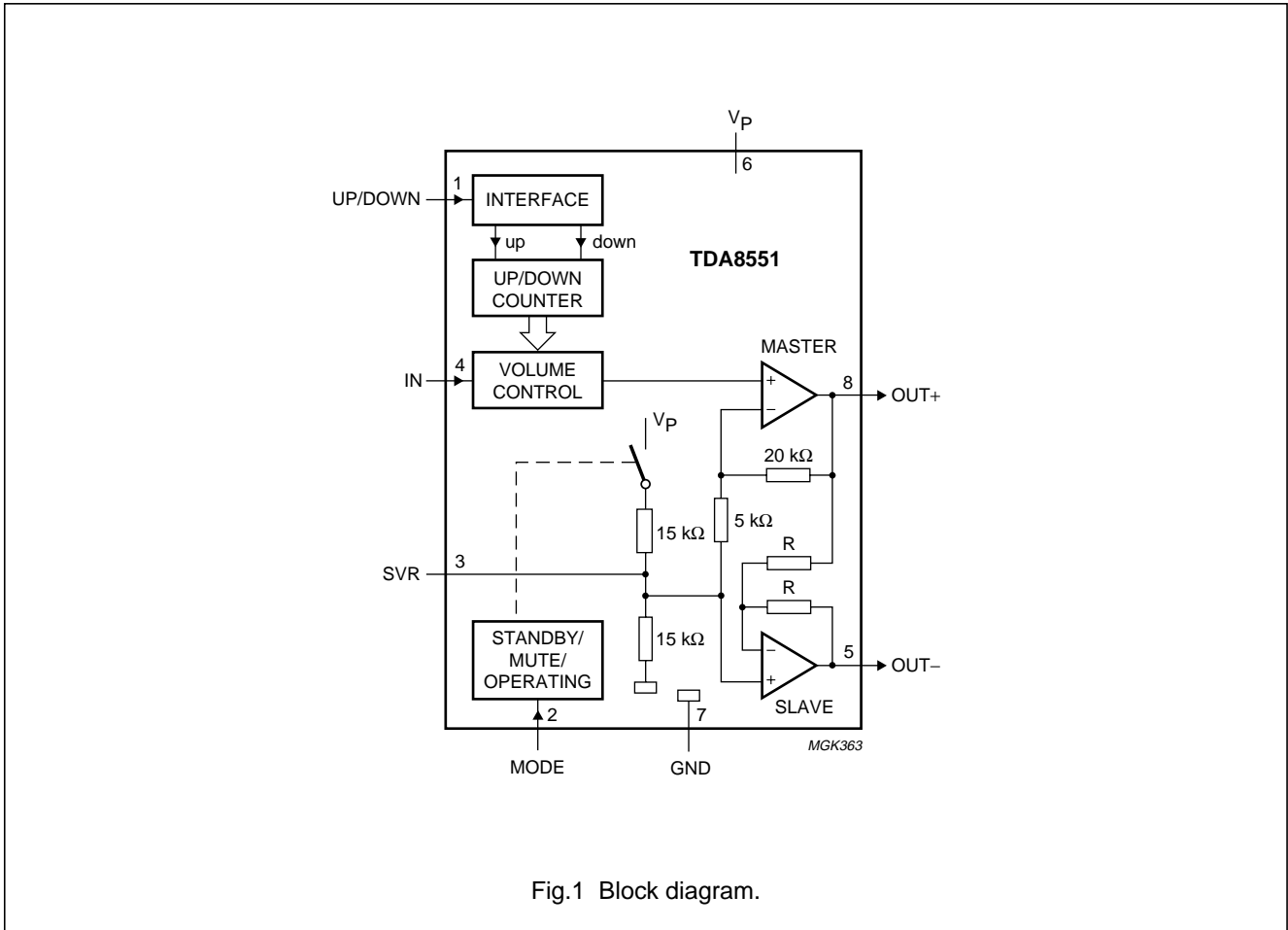

PINNING

SYMBOL	PIN	DESCRIPTION
UP/DOWN	1	digital trinary input for volume control
MODE	2	digital trinary input for mode selection (standby, mute, operating)
SVR	3	half supply voltage, decoupling ripple rejection
IN	4	audio input
OUT-	5	negative loudspeaker output terminal
VP	6	supply voltage
GND	7	ground
OUT+	8	positive loudspeaker output terminal

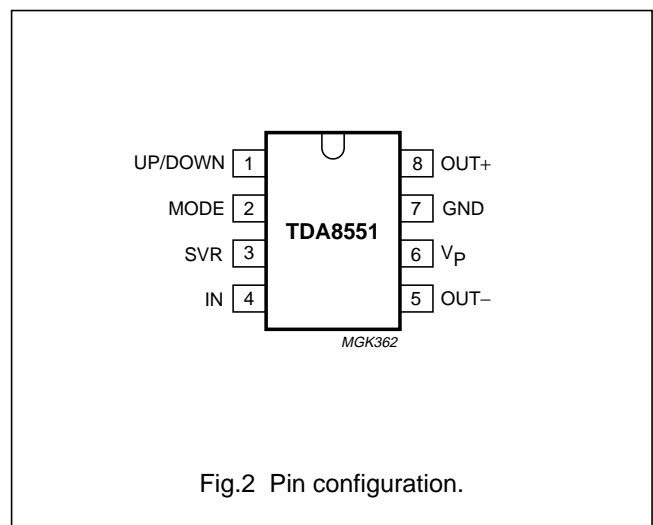

1 W BTL audio amplifier with digital volume control

TDA8551

FUNCTIONAL DESCRIPTION

The TDA8551; TDA8551T is a 1 W BTL audio power amplifier capable of delivering 1 W output power to an 8 Ω load at THD = 10% using a 5 V power supply. The gain of the amplifier can be set by the digital volume control. In the maximum volume setting the gain is 20 dB. Using the MODE pin the device can be switched to the standby condition, the mute condition and the normal operating condition. The device is protected by an internal thermal shutdown protection mechanism.

Power amplifier

The power amplifier is a Bridge Tied Load (BTL) amplifier with a complementary CMOS output stage. The total voltage loss for both output power MOS transistors is within 1 V and with a 5 V supply and an 8 Ω loudspeaker an output power of 1 W can be delivered. The total gain of this power amplifier is internally fixed at 20 dB.

Volume control

The volume control operates as a digital controlled attenuator between the audio input pin and the power amplifier. In the maximum volume control setting the attenuation is 0 dB and in the minimum volume control setting the typical attenuation is 80 dB. The attenuation can be set in 64 steps by the UP/DOWN pin.

This UP/DOWN pin is a trinary input:

- Floating UP/DOWN pin: volume remains unchanged
- Negative pulses: setting volume towards minimum
- Positive pulses: setting volume towards maximum.

Each pulse on the UP/DOWN pin results in a change in gain of $80/64 = 1.25$ dB (typical value). In the basic application the UP/DOWN pin is switched to ground or V_P by a double push-button. When the supply voltage is initially connected, after a complete removal of the supply, the initial state of the volume control is an attenuation of 40 dB (low volume), so the gain of the total amplifier is -20 dB. After powering-up, some positive pulses have to be applied to the UP/DOWN pin for turning up to listening volume. When the device is switched with the MODE select pin to the mute or the standby condition, the volume control attenuation setting remains on its value, assumed that the voltage on pin V_P does not fall below the minimum supply voltage. After switching the device back to the operation mode, the previous volume setting is maintained.

Mode select pin

The device is in the standby mode (with a very low current consumption) if the voltage at the MODE pin is between V_P and $V_P - 0.5$ V. At a mode select voltage level of less than 0.5 V the amplifier is fully operational. In the range between 1 V and $V_P - 1.4$ V the amplifier is in the mute condition. The mute condition is useful for using it as a 'fast mute'; in this mode output signal is suppressed, while the volume setting remains at its value. It is advised to keep the device in the mute condition while the input capacitor is being charged. This can be done by holding the MODE pin at a level of $0.5V_P$, or by waiting approximately 100 ms before giving the first volume-UP pulses.

1 W BTL audio amplifier with digital volume control

TDA8551

LIMITING VALUES

In accordance with the Absolute Maximum Rating System (IEC 134).

SYMBOL	PARAMETER	CONDITIONS	MIN.	MAX.	UNIT
V_P	supply voltage		-0.3	+5.5	V
V_I	input voltage		-0.3	$V_P + 0.3$	V
I_{ORM}	repetitive peak output current		-	1	A
T_{stg}	storage temperature		-55	+150	°C
T_{amb}	operating temperature		-40	+85	°C
V_{sc}	AC and DC short-circuit safe voltage		-	5.5	V
P_{tot}	maximum power dissipation	SO8	-	0.8	W
		DIP8	-	1.2	W

QUALITY SPECIFICATION

Quality according to "SNW-FQ-611 part E", if this type is used as an audio amplifier. Quality specifications are listed in the "Quality reference handbook", order number 9397 750 00192.

THERMAL CHARACTERISTICS

SYMBOL	PARAMETER	CONDITIONS	VALUE	UNIT
$R_{th\ j-a}$	thermal resistance from junction to ambient	in free air		
	SO8		160	K/W
	DIP8		100	K/W

1 W BTL audio amplifier with digital volume control

TDA8551

CHARACTERISTICS

$V_P = 5\text{ V}$; $T_{\text{amb}} = 25\text{ °C}$; $R_L = 8\text{ }\Omega$; $V_{\text{MODE}} = 0\text{ V}$; total gain setting at +7 dB (unless otherwise specified); measured in test circuit of Fig.4.

SYMBOL	PARAMETER	CONDITIONS	MIN.	TYP.	MAX.	UNIT
DC characteristics						
V_P	supply voltage		2.7	5	5.5	V
I_q	quiescent current	$R_L = \infty$; note 1	–	6	10	mA
I_{stb}	standby current	$V_{\text{MODE}} = V_P$	–	–	10	μA
V_O	DC output voltage	note 2	–	2.5	–	V
$ V_{\text{OUT}+} - V_{\text{OUT}-} $	differential output offset		–	–	50	mV
Mode select pin						
V_{MODE}	input voltage	standby mode	$V_P - 0.5$	–	V_P	V
		mute mode	1	–	$V_P - 1.4$	V
		operating mode	0	–	0.5	V
I_{MODE}	input current	$0 < V_{\text{MODE}} < V_P$	–	–	100	nA
α	mute attenuation	note 3	80	90	–	dB
Volume control						
t_{rep}	pulse repetition time		100	–	–	ns
$V_{\text{th(UP)}}$	UP/DOWN pin up threshold level		4.2	–	V_P	V
$V_{\text{float(max)}}$	UP/DOWN pin floating high level		–	–	3.4	V
$V_{\text{float(min)}}$	UP/DOWN pin floating low level		1.0	–	–	V
$V_{\text{th(DOWN)}}$	UP/DOWN pin down threshold level		0	–	0.6	V
$I_{\text{UP/DOWN}}$	input current UP/DOWN pin	$0 < V_{\text{UP/DOWN}} < V_P$	–	–	200	μA
$G_{V(\text{max})}$	maximum voltage gain (including power amplifier)		19	20	21	dB
$G_{V(\text{min})}$	minimum voltage gain (including power amplifier)		–62	–60	–58	dB
n_{vol}	number of volume steps		–	64	–	
ΔG_V	voltage gain variation per step		–	1.25	–	dB
Z_i	input impedance		14	20	–	k Ω
$V_{i(\text{rms})(\text{max})}$	maximum input voltage (RMS value)		–	–	2.0	V
AC characteristics (f = 1 kHz)						
P_o	output power	THD = 10%	1	1.4	–	W
		THD = 0.5%	0.6	1.0	–	W
THD	total harmonic distortion	$P_o = 0.5\text{ W}$; note 4	–	0.15	0.5	%
$V_{n(o)}$	noise output voltage	note 5	–	60	100	μV
SVRR	supply voltage ripple rejection	note 6	48	53	–	dB
$V_{i(\text{IN})(\text{max})}$	maximum input voltage on pin IN	THD = 1%; $G_V = -50\text{ dB}$ to 0 dB	–	–	2.0	V

1 W BTL audio amplifier with digital volume control

TDA8551

Notes to the Characteristics

1. With a load connected at the outputs the quiescent current will increase, the maximum of this increase being equal to the DC output offset voltage divided by R_L .
2. The DC output voltage with respect to ground is approximately $0.5V_P$.
3. Output voltage in mute position is measured with an input of 1 V (RMS), including noise, in a bandwidth of 20 kHz.
4. Total gain setting at +20 dB.
5. The noise output voltage is measured at the output in a frequency band from 20 Hz to 20 kHz (unweighted), input source impedance $R_{source} = 0 \Omega$.
6. Supply voltage ripple rejection is measured at the output, with a source impedance of $R_{source} = 0 \Omega$ at the input. The ripple voltage is a sine wave with frequency of 1 kHz and an amplitude of 100 mV (RMS) is applied to the positive supply rail.

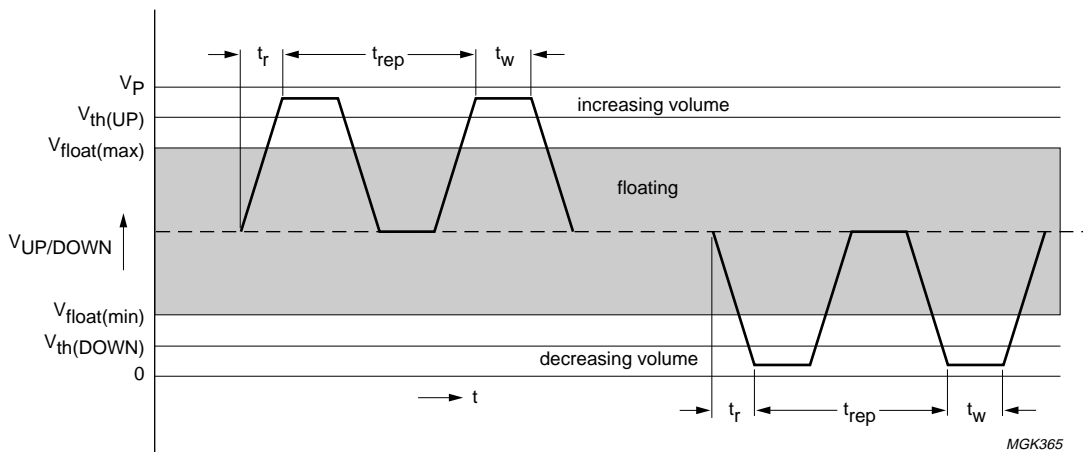

The rise time (t_r) and the width of the pulse (t_w) are not critical.

Fig.3 Timing UP/DOWN pin.

1 W BTL audio amplifier with digital volume control

TDA8551

TEST AND APPLICATION INFORMATION

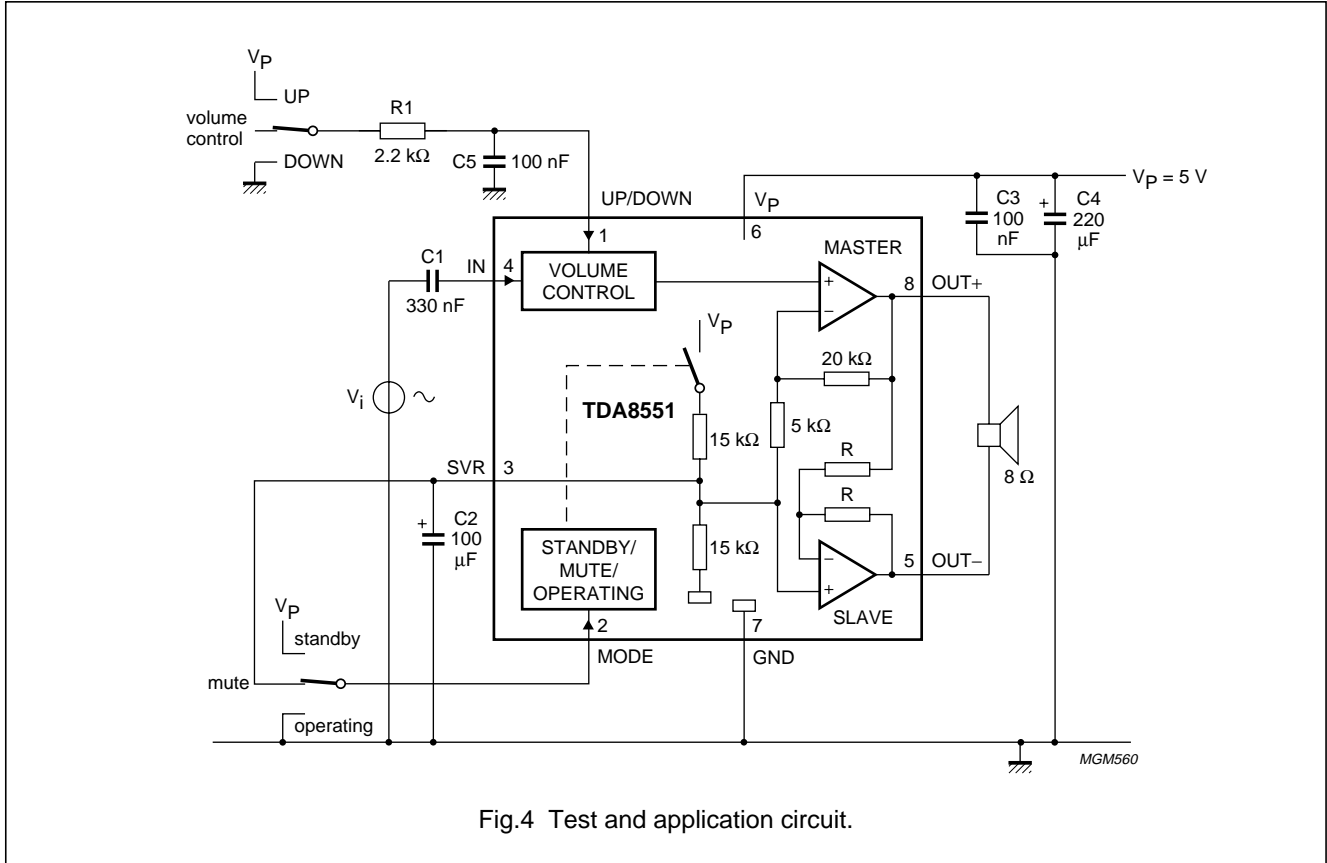

Fig.4 Test and application circuit.

Reduction of the value of capacitor C2 results in a decrease of the SVRR performance at low frequencies (see Fig.9).

The UP/DOWN pin can be driven by a 3-state logic output stage (microcontroller) without extra external components. If the UP/DOWN pin is driven by push-buttons, then it is advised to have an RC filter between the buttons and the UP/DOWN pin. Advised values for the RC filter are 2.2 kΩ and 100 nF.

The volume control circuit responds to the trailing edge of the pulse on the volume pin; connecting to V_P results in a one step (1.25 dB) higher gain; connecting to ground results in a one step lower gain.

To avoid audible plops while switching the supply voltage on and off pin MODE has to be connected to V_P (standby condition) during charge or discharge of the input and SVRR capacitors.

The measured thermal resistance of the IC package is highly dependent on the configuration and size of the application board. Data may not be comparable between different semiconductor manufacturers because the application boards and test methods are not standardized yet. In addition, the thermal performance of packages for a specific application may be different than presented here, because the configuration of the application boards (copper area) may be different. Philips Semiconductors uses FR-4 type application boards with 1 oz. copper traces with solder coating. The measurements have been carried out with vertical placed boards.

1 W BTL audio amplifier with digital volume control

TDA8551

When a practical PCB layout is used with wider copper tracks and some extra copper added both to the IC pin connections and underneath the IC, the thermal resistance from junction to ambient can be reduced. Without these measures $R_{th\ j-a} = 160\ K/W$ for the SO8 package; see Chapter "Thermal characteristics". The power dissipation can be calculated as follows:

$$P = \frac{T_{amb}}{R_{th\ j-a}}$$

For a maximum ambient temperature of 50 °C, $V_P = 5\ V$ and $R_L = 8\ \Omega$ this results in a worst case sine wave dissipation of 0.63 W.

Figures 5 to 15 represent test results obtained while using the test circuit given in Fig.4. The following test conditions apply: $T_{amb} = 25\ ^\circ C$; $V_P = 5\ V$; $f = 1\ kHz$; $R_L = 8\ \Omega$; $G_v = 20\ dB$; audio bandwidth from 22 Hz to 22 kHz (except for Figs 8 and 9); unless otherwise specified.

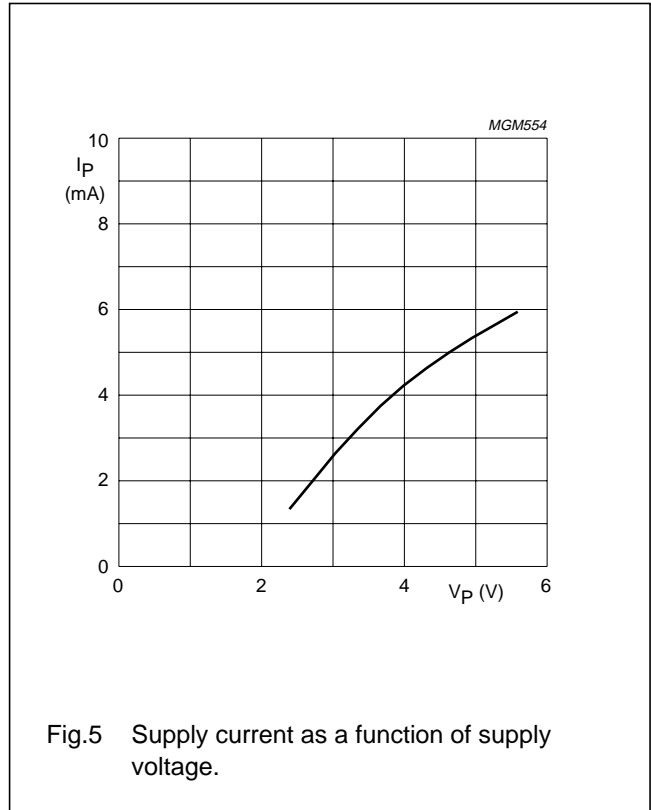
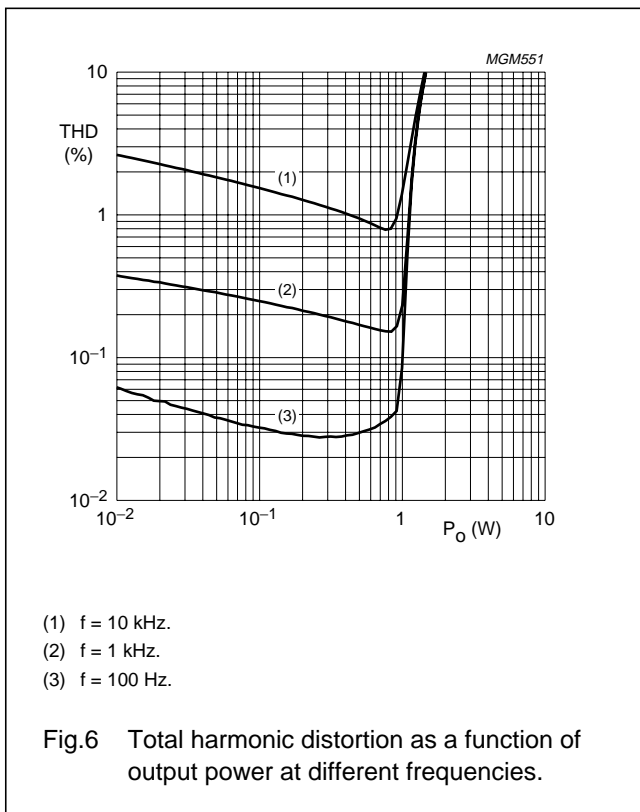
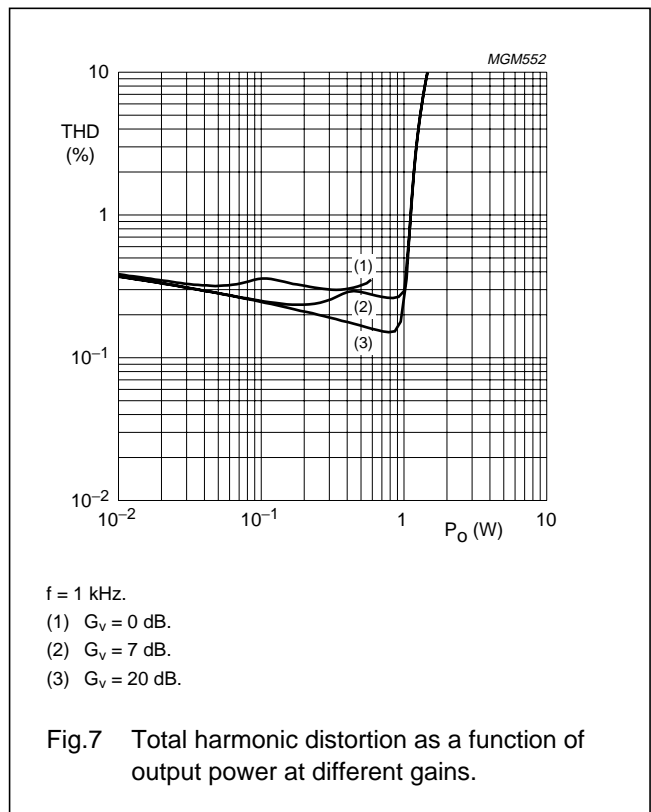

Fig.5 Supply current as a function of supply voltage.



- (1) $f = 10\ kHz.$
- (2) $f = 1\ kHz.$
- (3) $f = 100\ Hz.$

Fig.6 Total harmonic distortion as a function of output power at different frequencies.



- $f = 1\ kHz.$
- (1) $G_v = 0\ dB.$
- (2) $G_v = 7\ dB.$
- (3) $G_v = 20\ dB.$

Fig.7 Total harmonic distortion as a function of output power at different gains.

1 W BTL audio amplifier with digital volume control

TDA8551

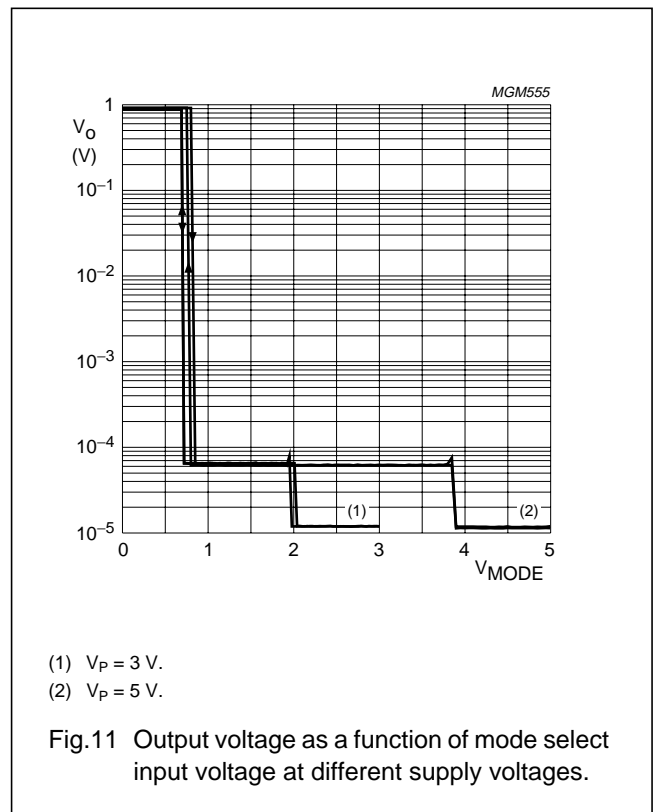
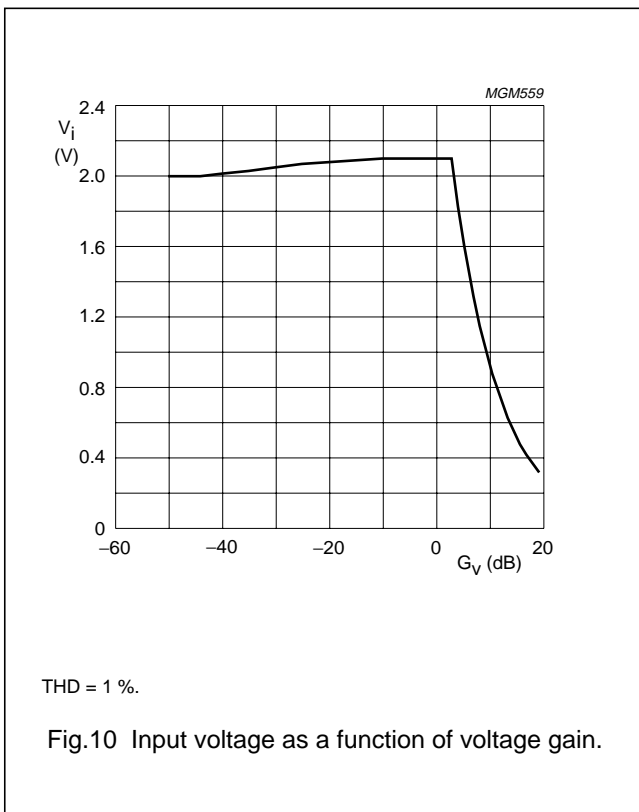
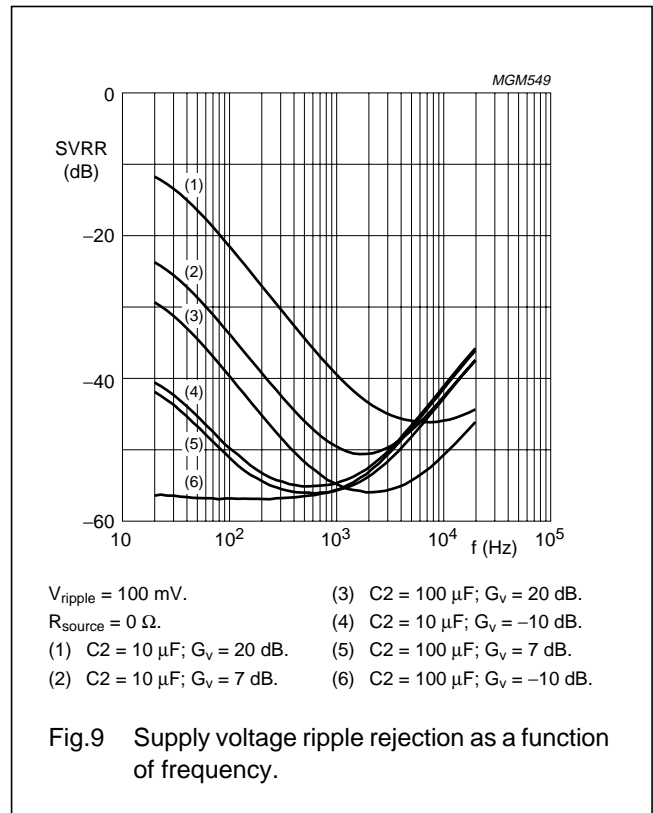
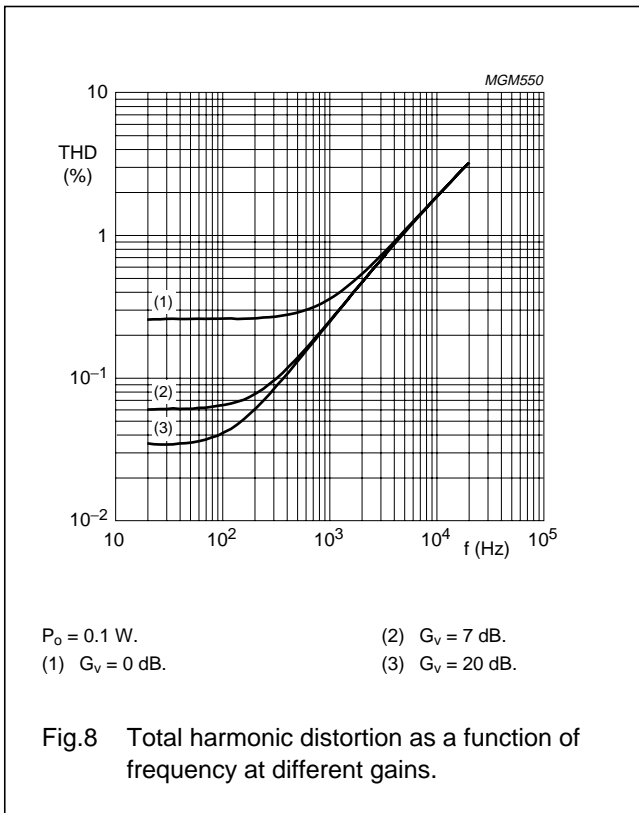

1 W BTL audio amplifier with digital volume control

TDA8551

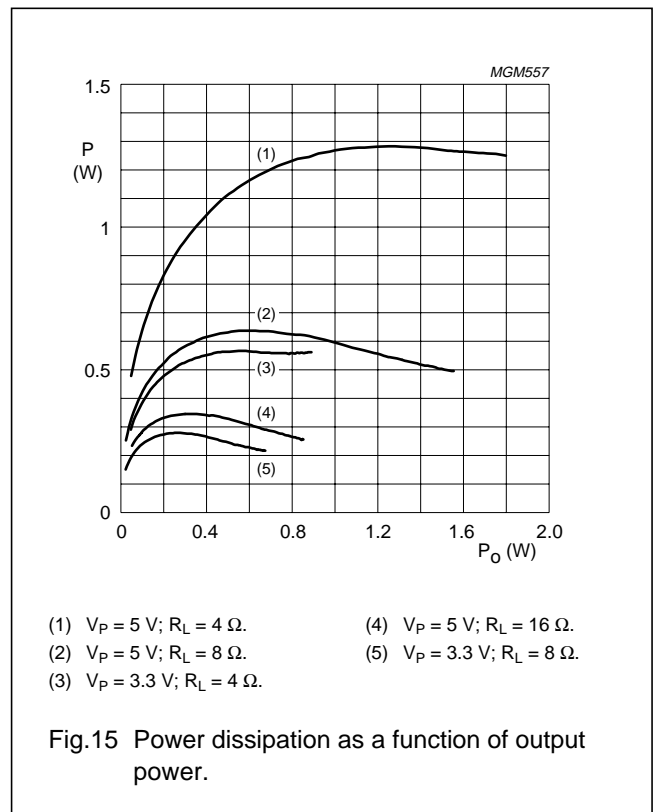
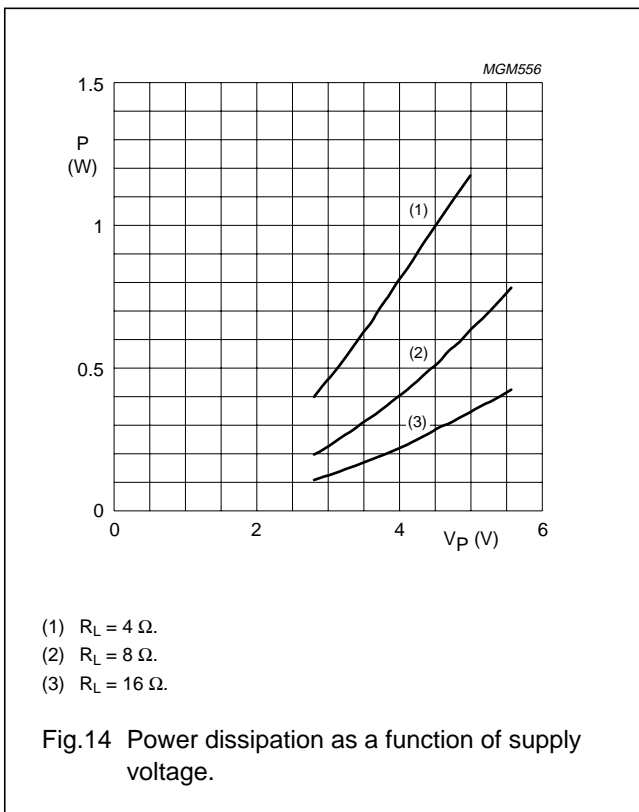
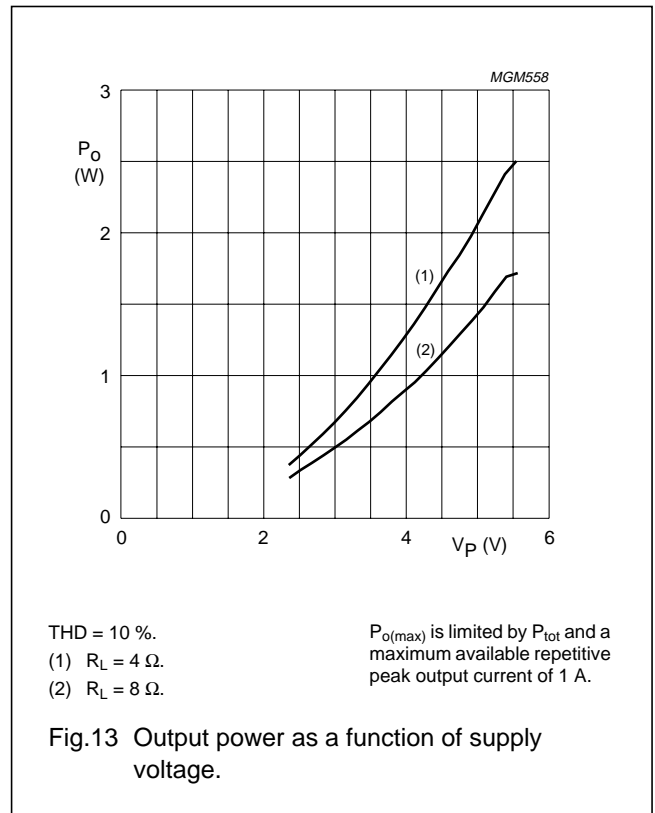
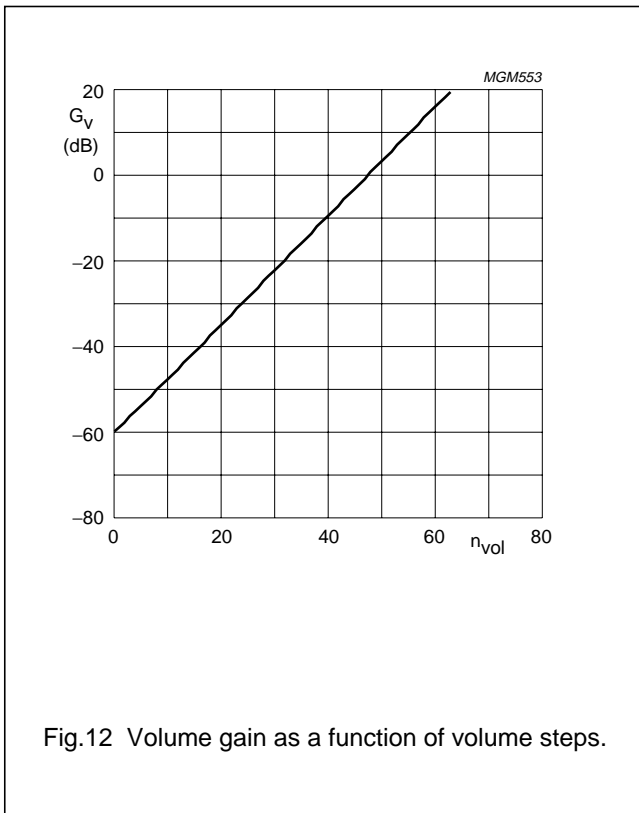

1 W BTL audio amplifier with digital volume control

TDA8551

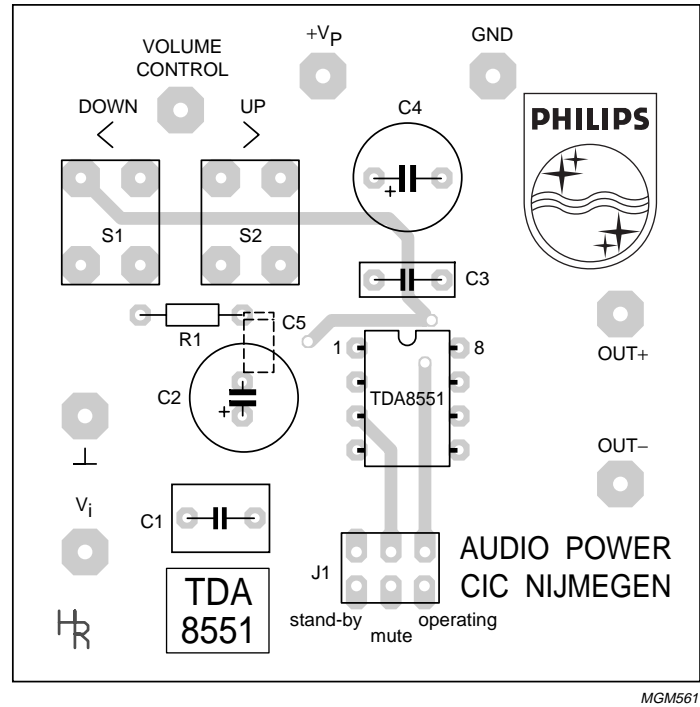
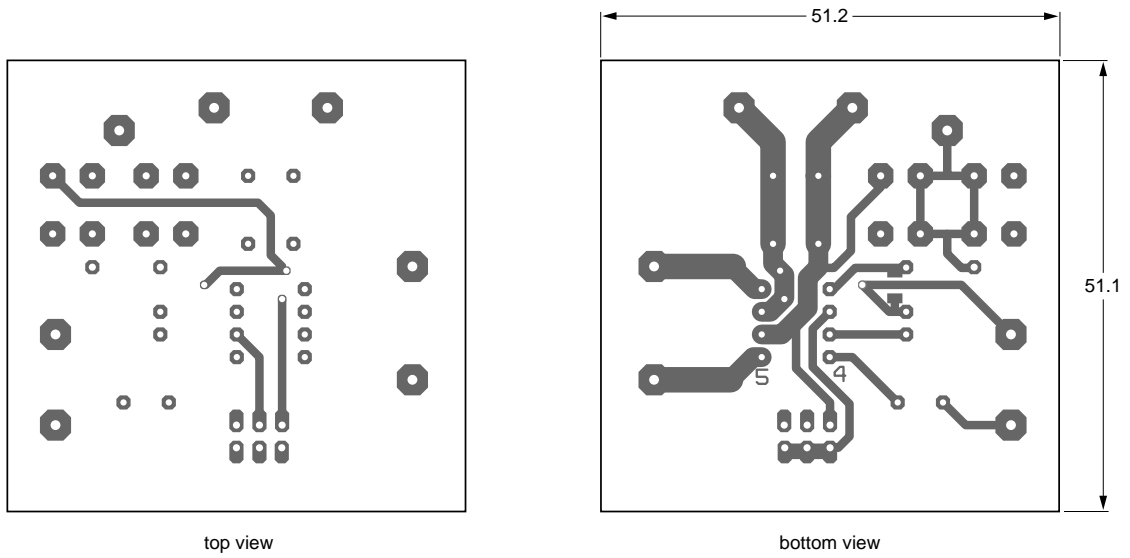

Dimensions in mm.

Fig.16 Layout of printed-circuit board.

1 W BTL audio amplifier with digital volume control

TDA8551

PACKAGE OUTLINES

S08: plastic small outline package; 8 leads; body width 3.9 mm

SOT96-1

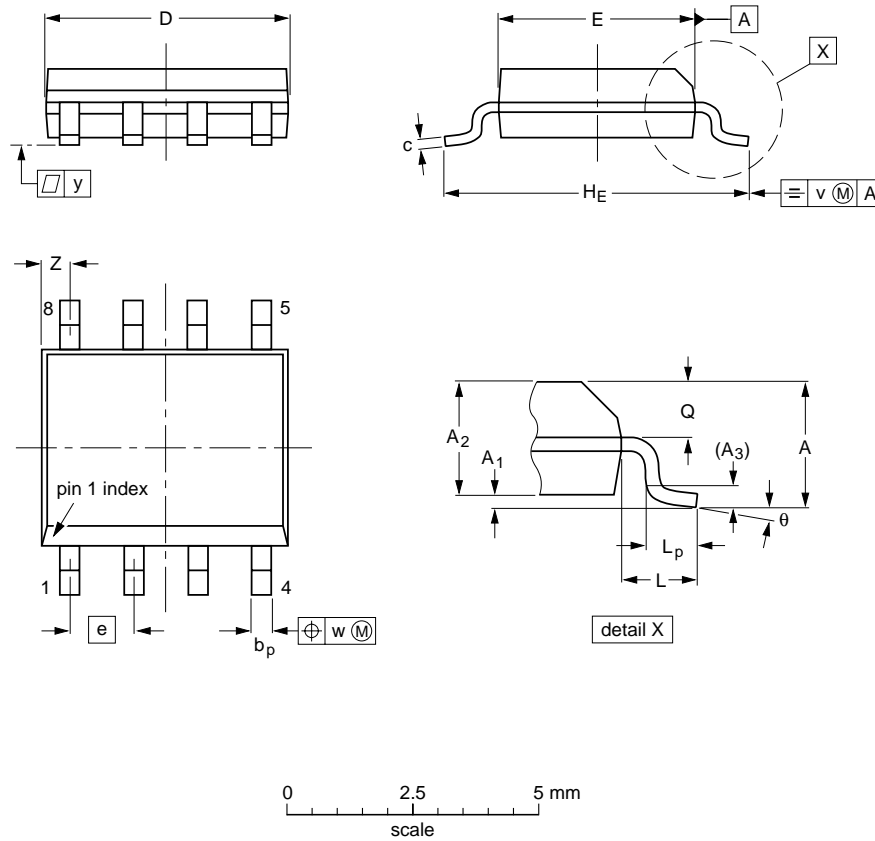

DIMENSIONS (inch dimensions are derived from the original mm dimensions)

UNIT	A max.	A ₁	A ₂	A ₃	b _p	c	D ⁽¹⁾	E ⁽²⁾	e	H _E	L	L _p	Q	v	w	y	Z ⁽¹⁾	θ
mm	1.75	0.25 0.10	1.45 1.25	0.25	0.49 0.36	0.25 0.19	5.0 4.8	4.0 3.8	1.27	6.2 5.8	1.05	1.0 0.4	0.7 0.6	0.25	0.25	0.1	0.7 0.3	8° 0°
inches	0.069	0.010 0.004	0.057 0.049	0.01	0.019 0.014	0.0100 0.0075	0.20 0.19	0.16 0.15	0.050	0.244 0.228	0.041	0.039 0.016	0.028 0.024	0.01	0.01	0.004	0.028 0.012	

Notes

1. Plastic or metal protrusions of 0.15 mm maximum per side are not included.
2. Plastic or metal protrusions of 0.25 mm maximum per side are not included.

OUTLINE VERSION	REFERENCES				EUROPEAN PROJECTION	ISSUE DATE
	IEC	JEDEC	EIAJ			
SOT96-1	076E03S	MS-012AA				95-02-04 97-05-22

1 W BTL audio amplifier with digital volume control

TDA8551

DIP8: plastic dual in-line package; 8 leads (300 mil)

SOT97-1

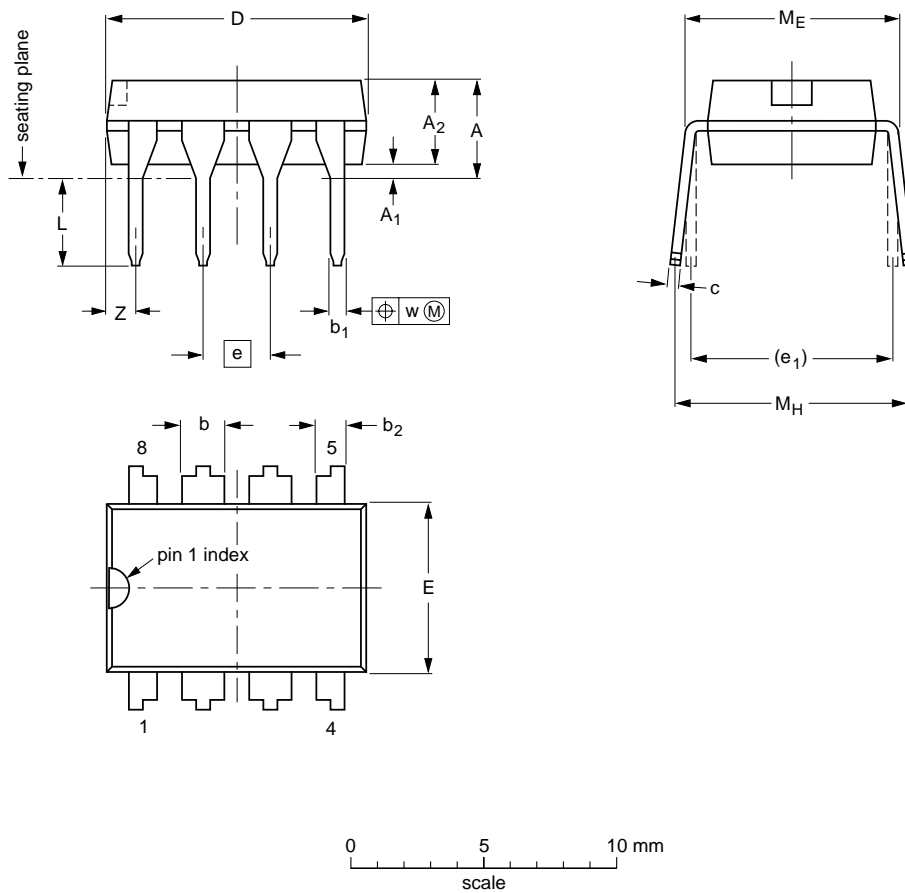

DIMENSIONS (inch dimensions are derived from the original mm dimensions)

UNIT	A max.	A ₁ min.	A ₂ max.	b	b ₁	b ₂	c	D ⁽¹⁾	E ⁽¹⁾	e	e ₁	L	M _E	M _H	w	Z ⁽¹⁾ max.
mm	4.2	0.51	3.2	1.73 1.14	0.53 0.38	1.07 0.89	0.36 0.23	9.8 9.2	6.48 6.20	2.54	7.62	3.60 3.05	8.25 7.80	10.0 8.3	0.254	1.15
inches	0.17	0.020	0.13	0.068 0.045	0.021 0.015	0.042 0.035	0.014 0.009	0.39 0.36	0.26 0.24	0.10	0.30	0.14 0.12	0.32 0.31	0.39 0.33	0.01	0.045

Note

1. Plastic or metal protrusions of 0.25 mm maximum per side are not included.

OUTLINE VERSION	REFERENCES			EUROPEAN PROJECTION	ISSUE DATE
	IEC	JEDEC	EIAJ		
SOT97-1	050G01	MO-001AN			92-11-17 95-02-04

1 W BTL audio amplifier with digital volume control

TDA8551

SOLDERING

Introduction

There is no soldering method that is ideal for all IC packages. Wave soldering is often preferred when through-hole and surface mounted components are mixed on one printed-circuit board. However, wave soldering is not always suitable for surface mounted ICs, or for printed-circuits with high population densities. In these situations reflow soldering is often used.

This text gives a very brief insight to a complex technology. A more in-depth account of soldering ICs can be found in our "IC Package Databook" (order code 9398 652 90011).

DIP

SOLDERING BY DIPPING OR BY WAVE

The maximum permissible temperature of the solder is 260 °C; solder at this temperature must not be in contact with the joint for more than 5 seconds. The total contact time of successive solder waves must not exceed 5 seconds.

The device may be mounted up to the seating plane, but the temperature of the plastic body must not exceed the specified maximum storage temperature ($T_{stg\ max}$). If the printed-circuit board has been pre-heated, forced cooling may be necessary immediately after soldering to keep the temperature within the permissible limit.

REPAIRING SOLDERED JOINTS

Apply a low voltage soldering iron (less than 24 V) to the lead(s) of the package, below the seating plane or not more than 2 mm above it. If the temperature of the soldering iron bit is less than 300 °C it may remain in contact for up to 10 seconds. If the bit temperature is between 300 and 400 °C, contact may be up to 5 seconds.

SO

REFLOW SOLDERING

Reflow soldering techniques are suitable for all SO packages.

Reflow soldering requires solder paste (a suspension of fine solder particles, flux and binding agent) to be applied to the printed-circuit board by screen printing, stencilling or pressure-syringe dispensing before package placement.

Several techniques exist for reflowing; for example, thermal conduction by heated belt. Dwell times vary between 50 and 300 seconds depending on heating method. Typical reflow temperatures range from 215 to 250 °C.

Preheating is necessary to dry the paste and evaporate the binding agent. Preheating duration: 45 minutes at 45 °C.

WAVE SOLDERING

Wave soldering techniques can be used for all SO packages if the following conditions are observed:

- A double-wave (a turbulent wave with high upward pressure followed by a smooth laminar wave) soldering technique should be used.
- The longitudinal axis of the package footprint must be parallel to the solder flow.
- The package footprint must incorporate solder thieves at the downstream end.

During placement and before soldering, the package must be fixed with a droplet of adhesive. The adhesive can be applied by screen printing, pin transfer or syringe dispensing. The package can be soldered after the adhesive is cured.

Maximum permissible solder temperature is 260 °C, and maximum duration of package immersion in solder is 10 seconds, if cooled to less than 150 °C within 6 seconds. Typical dwell time is 4 seconds at 250 °C.

A mildly-activated flux will eliminate the need for removal of corrosive residues in most applications.

REPAIRING SOLDERED JOINTS

Fix the component by first soldering two diagonally-opposite end leads. Use only a low voltage soldering iron (less than 24 V) applied to the flat part of the lead. Contact time must be limited to 10 seconds at up to 300 °C. When using a dedicated tool, all other leads can be soldered in one operation within 2 to 5 seconds between 270 and 320 °C.

1 W BTL audio amplifier with digital volume control

TDA8551

DEFINITIONS

Data sheet status	
Objective specification	This data sheet contains target or goal specifications for product development.
Preliminary specification	This data sheet contains preliminary data; supplementary data may be published later.
Product specification	This data sheet contains final product specifications.
Limiting values	
Limiting values given are in accordance with the Absolute Maximum Rating System (IEC 134). Stress above one or more of the limiting values may cause permanent damage to the device. These are stress ratings only and operation of the device at these or at any other conditions above those given in the Characteristics sections of the specification is not implied. Exposure to limiting values for extended periods may affect device reliability.	
Application information	
Where application information is given, it is advisory and does not form part of the specification.	

LIFE SUPPORT APPLICATIONS

These products are not designed for use in life support appliances, devices, or systems where malfunction of these products can reasonably be expected to result in personal injury. Philips customers using or selling these products for use in such applications do so at their own risk and agree to fully indemnify Philips for any damages resulting from such improper use or sale.

1 W BTL audio amplifier with digital volume control

TDA8551

NOTES

1 W BTL audio amplifier with digital volume control

TDA8551

NOTES

1 W BTL audio amplifier with digital volume control

TDA8551

NOTES

Philips Semiconductors – a worldwide company

Argentina: see South America

Australia: 34 Waterloo Road, NORTH RYDE, NSW 2113,
Tel. +61 2 9805 4455, Fax. +61 2 9805 4466

Austria: Computerstr. 6, A-1101 WIEN, P.O. Box 213, Tel. +43 160 1010,
Fax. +43 160 101 1210

Belarus: Hotel Minsk Business Center, Bld. 3, r. 1211, Volodarski Str. 6,
220050 MINSK, Tel. +375 172 200 733, Fax. +375 172 200 773

Belgium: see The Netherlands

Brazil: see South America

Bulgaria: Philips Bulgaria Ltd., Energoproject, 15th floor,
51 James Bourchier Blvd., 1407 SOFIA,
Tel. +359 2 689 211, Fax. +359 2 689 102

Canada: PHILIPS SEMICONDUCTORS/COMPONENTS,
Tel. +1 800 234 7381

China/Hong Kong: 501 Hong Kong Industrial Technology Centre,
72 Tat Chee Avenue, Kowloon Tong, HONG KONG,
Tel. +852 2319 7888, Fax. +852 2319 7700

Colombia: see South America

Czech Republic: see Austria

Denmark: Prags Boulevard 80, PB 1919, DK-2300 COPENHAGEN S,
Tel. +45 32 88 2636, Fax. +45 31 57 0044

Finland: Sinikalliontie 3, FIN-02630 ESPOO,
Tel. +358 9 615800, Fax. +358 9 61580920

France: 51 Rue Carnot, BP317, 92156 SURESNES Cedex,
Tel. +33 1 40 99 6161, Fax. +33 1 40 99 6427

Germany: Hammerbrookstraße 69, D-20097 HAMBURG,
Tel. +49 40 23 53 60, Fax. +49 40 23 536 300

Greece: No. 15, 25th March Street, GR 17778 TAVROS/ATHENS,
Tel. +30 1 4894 339/239, Fax. +30 1 4814 240

Hungary: see Austria

India: Philips INDIA Ltd, Band Box Building, 2nd floor,
254-D, Dr. Annie Besant Road, Worli, MUMBAI 400 025,
Tel. +91 22 493 8541, Fax. +91 22 493 0966

Indonesia: see Singapore

Ireland: Newstead, Clonskeagh, DUBLIN 14,
Tel. +353 1 7640 000, Fax. +353 1 7640 200

Israel: RAPAC Electronics, 7 Kehilat Saloniki St, PO Box 18053,
TEL AVIV 61180, Tel. +972 3 645 0444, Fax. +972 3 649 1007

Italy: PHILIPS SEMICONDUCTORS, Piazza IV Novembre 3,
20124 MILANO, Tel. +39 2 6752 2531, Fax. +39 2 6752 2557

Japan: Philips Bldg 13-37, Kohnan 2-chome, Minato-ku, TOKYO 108,
Tel. +81 3 3740 5130, Fax. +81 3 3740 5077

Korea: Philips House, 260-199 Itaewon-dong, Yongsan-ku, SEOUL,
Tel. +82 2 709 1412, Fax. +82 2 709 1415

Malaysia: No. 76 Jalan Universiti, 46200 PETALING JAYA, SELANGOR,
Tel. +60 3 750 5214, Fax. +60 3 757 4880

Mexico: 5900 Gateway East, Suite 200, EL PASO, TEXAS 79905,
Tel. +9-5 800 234 7381

Middle East: see Italy

Netherlands: Postbus 90050, 5600 PB EINDHOVEN, Bldg. VB,
Tel. +31 40 27 82785, Fax. +31 40 27 88399

New Zealand: 2 Wagener Place, C.P.O. Box 1041, AUCKLAND,
Tel. +64 9 849 4160, Fax. +64 9 849 7811

Norway: Box 1, Manglerud 0612, OSLO,
Tel. +47 22 74 8000, Fax. +47 22 74 8341

Philippines: Philips Semiconductors Philippines Inc.,
106 Valero St. Salcedo Village, P.O. Box 2108 MCC, MAKATI,
Metro MANILA, Tel. +63 2 816 6380, Fax. +63 2 817 3474

Poland: Ul. Lukiska 10, PL 04-123 WARSZAWA,
Tel. +48 22 612 2831, Fax. +48 22 612 2327

Portugal: see Spain

Romania: see Italy

Russia: Philips Russia, Ul. Usatcheva 35A, 119048 MOSCOW,
Tel. +7 095 755 6918, Fax. +7 095 755 6919

Singapore: Lorong 1, Toa Payoh, SINGAPORE 1231,
Tel. +65 350 2538, Fax. +65 251 6500

Slovakia: see Austria

Slovenia: see Italy

South Africa: S.A. PHILIPS Pty Ltd., 195-215 Main Road Martindale,
2092 JOHANNESBURG, P.O. Box 7430 Johannesburg 2000,
Tel. +27 11 470 5911, Fax. +27 11 470 5494

South America: Al. Vicente Pinzon, 173, 6th floor,
04547-130 SÃO PAULO, SP, Brazil,
Tel. +55 11 821 2333, Fax. +55 11 821 2382

Spain: Balmes 22, 08007 BARCELONA,
Tel. +34 3 301 6312, Fax. +34 3 301 4107

Sweden: Kottbygatan 7, Akalla, S-16485 STOCKHOLM,
Tel. +46 8 632 2000, Fax. +46 8 632 2745

Switzerland: Allmendstrasse 140, CH-8027 ZÜRICH,
Tel. +41 1 488 2686, Fax. +41 1 488 3263

Taiwan: Philips Semiconductors, 6F, No. 96, Chien Kuo N. Rd., Sec. 1,
TAIPEI, Taiwan Tel. +886 2 2134 2865, Fax. +886 2 2134 2874

Thailand: PHILIPS ELECTRONICS (THAILAND) Ltd.,
209/2 Sanpavuth-Bangna Road Prakanong, BANGKOK 10260,
Tel. +66 2 745 4090, Fax. +66 2 398 0793

Turkey: Talatpasa Cad. No. 5, 80640 GÜLTEPE/ISTANBUL,
Tel. +90 212 279 2770, Fax. +90 212 282 6707

Ukraine: PHILIPS UKRAINE, 4 Patrice Lumumba str., Building B, Floor 7,
252042 KIEV, Tel. +380 44 264 2776, Fax. +380 44 268 0461

United Kingdom: Philips Semiconductors Ltd., 276 Bath Road, Hayes,
MIDDLESEX UB3 5BX, Tel. +44 181 730 5000, Fax. +44 181 754 8421

United States: 811 East Arques Avenue, SUNNYVALE, CA 94088-3409,
Tel. +1 800 234 7381

Uruguay: see South America

Vietnam: see Singapore

Yugoslavia: PHILIPS, Trg N. Pasica 5/v, 11000 BEOGRAD,
Tel. +381 11 625 344, Fax. +381 11 635 777

For all other countries apply to: Philips Semiconductors,
International Marketing & Sales Communications, Building BE-p, P.O. Box 218,
5600 MD EINDHOVEN, The Netherlands, Fax. +31 40 27 24825

Internet: <http://www.semiconductors.philips.com>

© Philips Electronics N.V. 1998

SCA57

All rights are reserved. Reproduction in whole or in part is prohibited without the prior written consent of the copyright owner.

The information presented in this document does not form part of any quotation or contract, is believed to be accurate and reliable and may be changed without notice. No liability will be accepted by the publisher for any consequence of its use. Publication thereof does not convey nor imply any license under patent- or other industrial or intellectual property rights.

Printed in The Netherlands

545102/25/02/pp20

Date of release: 1998 Feb 23

Document order number: 9397 750 03173

Let's make things better.

**Philips
Semiconductors**



PHILIPS