

TriQuint Recommends the TGA4507 be used for New Designs

Ka Band Low Noise Amplifier

TGA1307

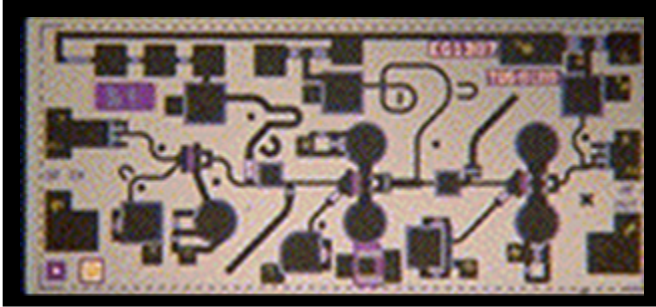

Chip Dimensions 2.54 mm x 1.15 mm

Key Features and Performance

- 0.25um pHEMT Technology
- 23-29 GHz Frequency Range
- 3.1 dB Nominal Noise Figure 28GHz
- 17 dB Nominal Gain
- OTOI > 22dBm
- 5V, 50 mA Self-Bias

Primary Applications

- Point-to-Point Radio
- Point-to-Multipoint Communications

Typical NF @ 25C

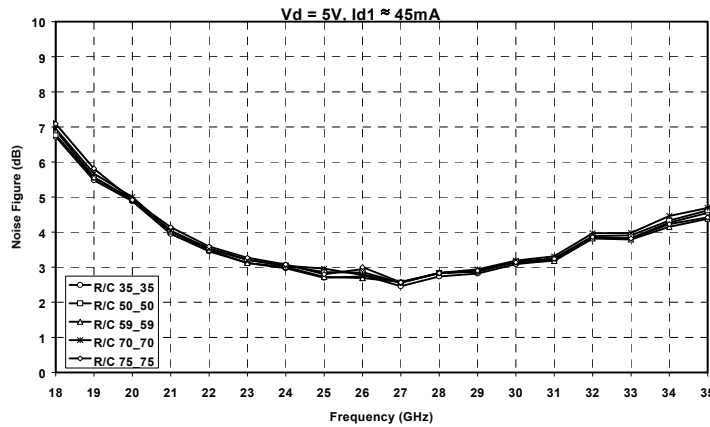

Typical Gain @ 25C

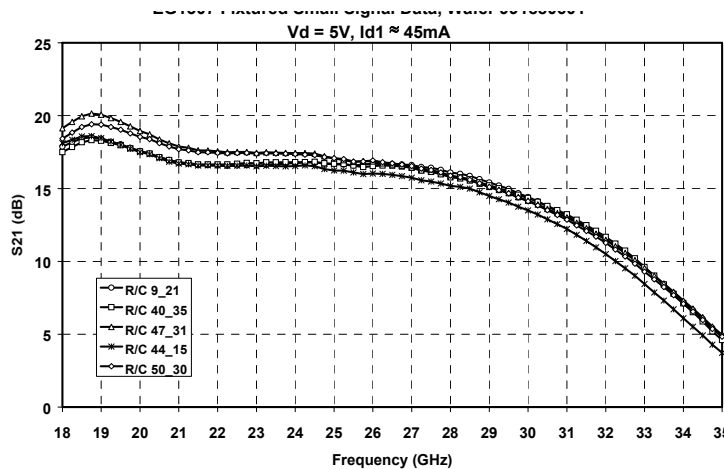

Note: Datasheet is subject to change without notice.

MAXIMUM RATINGS

Symbol	Parameter 4/	Value	Notes
V ⁺	Positive Supply Voltage	8 V	
I ⁺	Positive Supply Current	120 mA	3/
P _D	Power Dissipation	0.96 W	
P _{IN}	Input Continuous Wave Power	15.2 dBm	
T _{CH}	Operating Channel Temperature	150 °C	1/, 2/
T _M	Mounting Temperature (30 seconds)	320 °C	
T _{STG}	Storage Temperature	-65 °C to 150 °C	

- 1/ These ratings apply to each individual FET
- 2/ Junction operating temperature will directly affect the device mean time to failure (MTTF). For maximum life it is recommended that junction temperatures be maintained at the lowest possible levels.
- 3/ Total current for the entire MMIC
- 4/ These values represent the maximum operable values for this device

DC PROBE TESTS

(T_A = 25 °C ± 5°C)

Symbol	Parameter	Minimum	Maximum	Value
I _{SS}	Saturated Drain Current	30	141	mA
V _P	Pinch-off Voltage	-1.5	-0.5	V
BV _{GS}	Breakdown Voltage gate-source	-30	-8	V
BV _{GD}	Breakdown Voltage gate-drain	-30	-8	V

ON-WAFER RF PROBE CHARACTERISTICS

(T_A = 25 °C ± 5°C)

V_d = 5 V

Symbol	Parameter	Test Condition	Limit			Units
			Min	Typ	Max	
Gain	Small Signal Gain	F = 23 – 29 GHz	15		---	dB
IRL	Input Return Loss	F = 23 – 29 GHz	---		-4.5	dB
ORL	Output Return Loss	F = 23 – 29 GHz	---		-5	dB
PWR	Output Power @ P1dB	F = 28 GHz	14		---	dBm
NF	Noise Figure	F = 28 GHz	---		3.5	dB

EG1307 Fixtured Small Signal Data, Wafer 991880603
Vd = 5V, Id1 ≈ 45mA

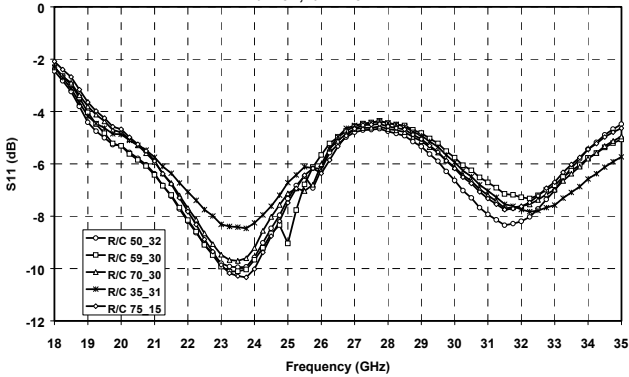

EG1307 Fixtured Small Signal Data, Wafer 991880603
Vd = 5V, Id1 ≈ 45mA

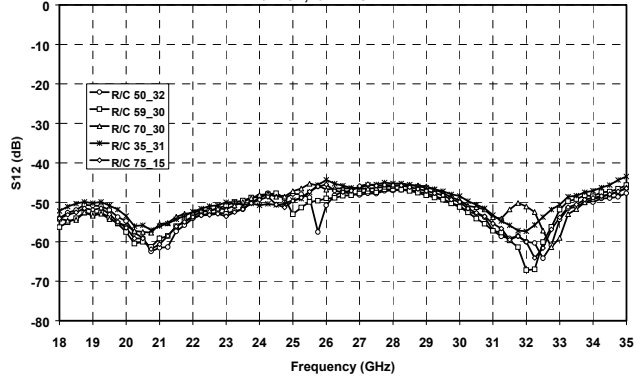

EG1307 Fixtured Small Signal Data, Wafer 991880603
Vd = 5V, Id1 ≈ 45mA

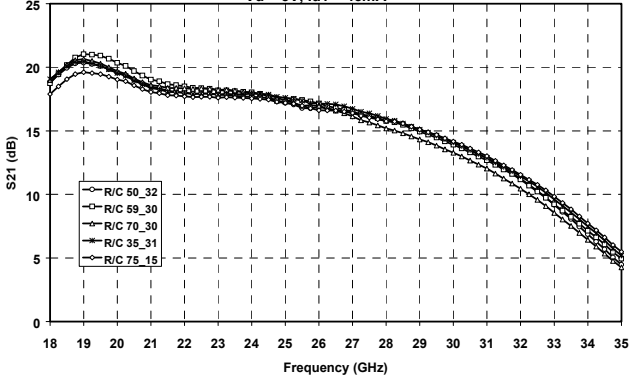

EG1307 Fixtured Small Signal Data, Wafer 991880603
Vd = 5V, Id1 ≈ 45mA

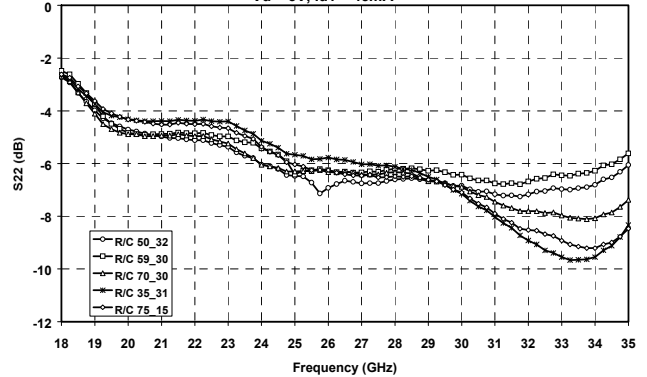

Typical Small Signal S-parameters at 25C.

TriQuint Recommends the TGA4507 be used for New Designs

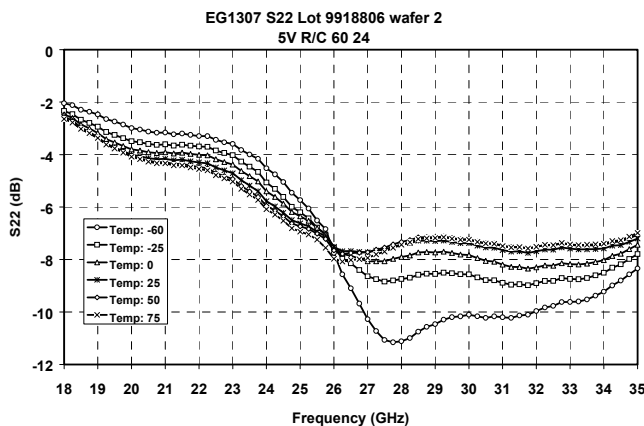
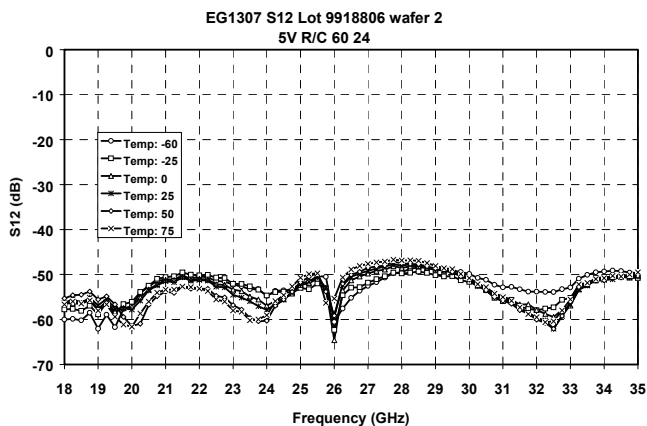
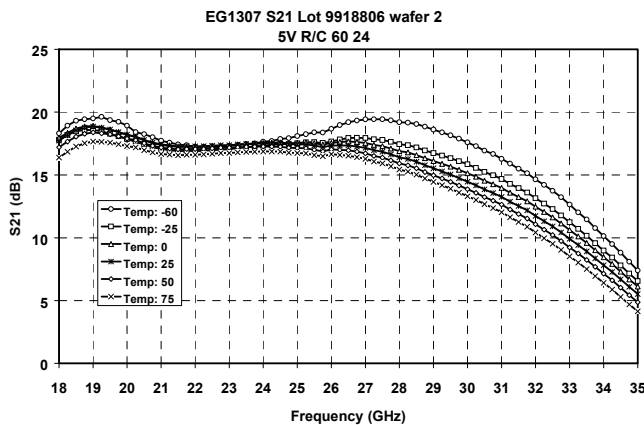
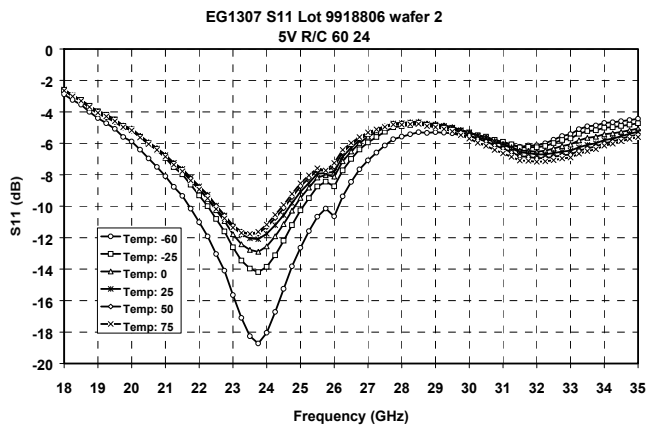

Small Signal S-parameters over temperature.

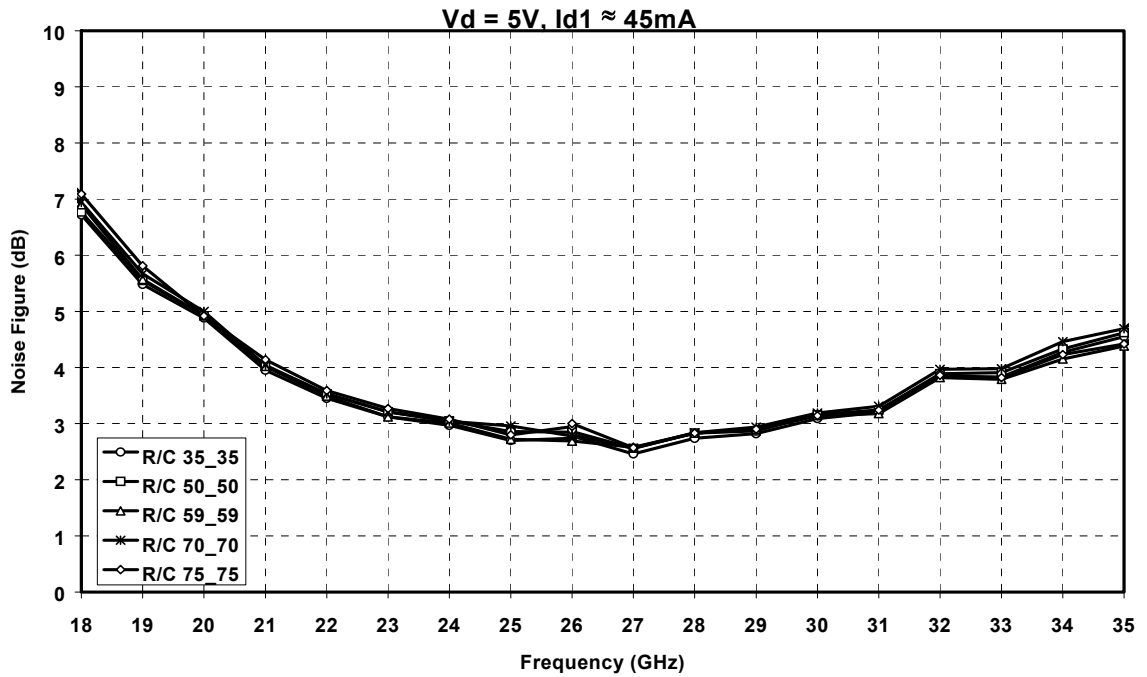

Typical Noise Figure - 5 devices

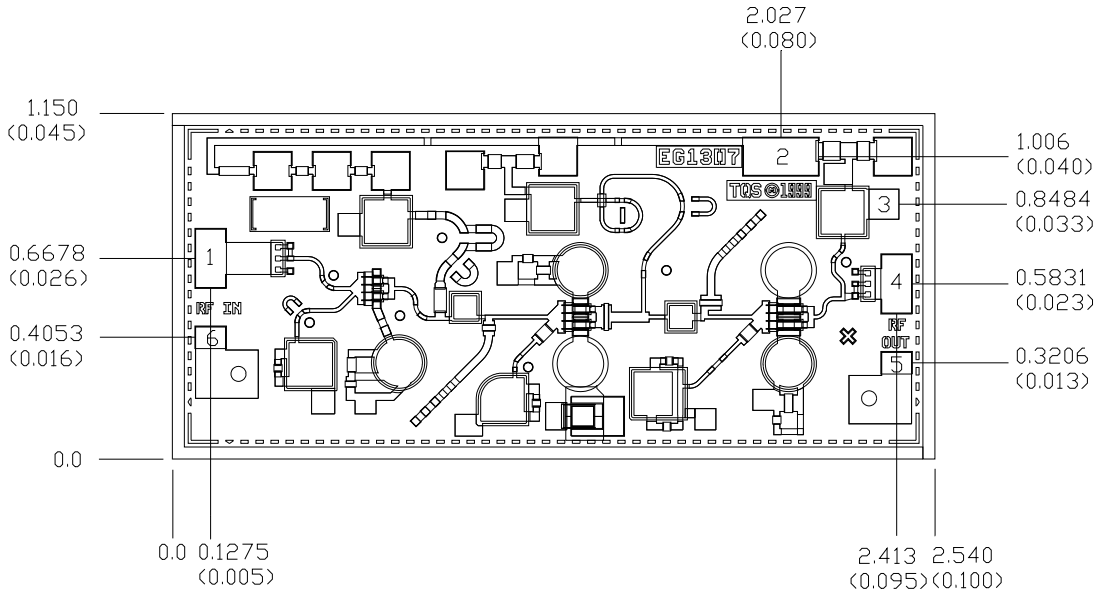

Units: millimeters (inches)

Thickness: 0.1016 (0.004) (reference only)

Chip to bond pad dimensions are shown to center of bond pad

Chip size tolerance: +/- 0.051 (0.002)

Bond Pad #1 (RF Input)	0.105 x 0.200 (0.004 x 0.008)
Bond Pad #2 (Vd)	0.130 x 0.253 (0.005 x 0.010)
Bond Pad #3 (GND)	0.100 x 0.100 (0.004 x 0.004)
Bond Pad #4 (RF Output)	0.105 x 0.200 (0.004 x 0.008)
Bond Pad #5 (GND)	0.075 x 0.105 (0.003 x 0.004)
Bond Pad #6 (GND)	0.075 x 0.105 (0.003 x 0.004)

TGA1307 - Mechanical Drawing

Not Recommended for New Designs

TriQuint Recommends the TGA4507 be used for New Designs

TGA1307

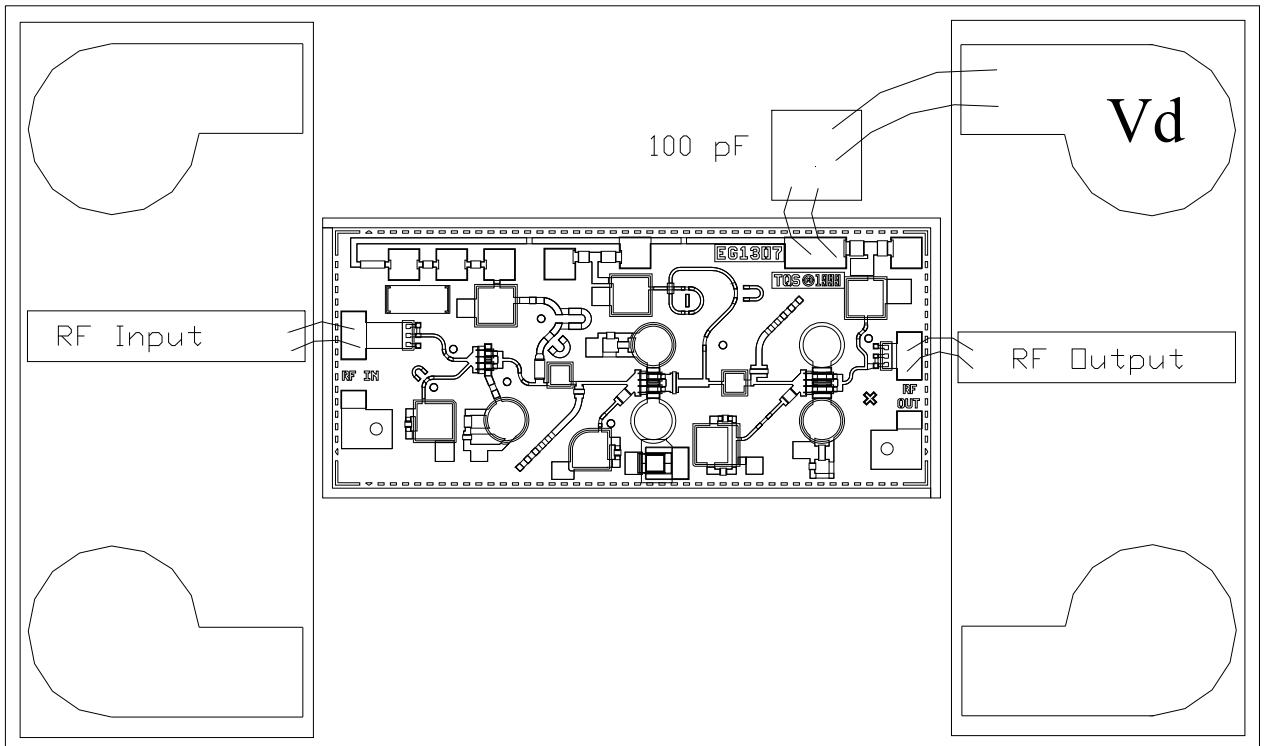

TGA1307 - Recommended Assembly Drawing

Assembly Process Notes

Reflow process assembly notes:

- Use AuSn (80/20) solder with limited exposure to temperatures at or above 300°C.
- An alloy station or conveyor furnace with reducing atmosphere should be used.
- No fluxes should be utilized.
- Coefficient of thermal expansion matching is critical for long-term reliability.
- Devices must be stored in a dry nitrogen atmosphere.

Component placement and adhesive attachment assembly notes:

- Vacuum pencils and/or vacuum collets are the preferred method of pick up.
- Air bridges must be avoided during placement.
- The force impact is critical during auto placement.
- Organic attachment can be used in low-power applications.
- Curing should be done in a convection oven; proper exhaust is a safety concern.
- Microwave or radiant curing should not be used because of differential heating.
- Coefficient of thermal expansion matching is critical.

Interconnect process assembly notes:

- Thermosonic ball bonding is the preferred interconnect technique.
- Force, time, and ultrasonics are critical parameters.
- Aluminum wire should not be used.
- Discrete FET devices with small pad sizes should be bonded with 0.0007-inch wire.
- Maximum stage temperature is 200°C.

GaAs MMIC devices are susceptible to damage from Electrostatic Discharge. Proper precautions should be observed during handling, assembly and test.