

Features and Benefits

- ❑ K-Bus Transceiver:
 - PNP-open emitter driver with slew rate control and current limitation
 - BUS input voltage -24V ... 30V (independently of V_S)
 - ISO 9141 and OBDII compliant
 - Possibility of BUS wake up
- ❑ Operating voltage $V_S = 5.5 \dots 16 \text{ V}$
- ❑ Very low standby current consumption $< 100 \mu\text{A}$ in normal mode ($< 50 \mu\text{A}$ in sleep mode)
- ❑ Linear low drop voltage regulator:
 - Output voltage $5\text{V} \pm 2\%$
 - Output current max. 100mA
 - Output current limitation
- ❑ Overtemperature shutdown
- ❑ Configurable reset time (15ms/100ms) and reset threshold voltage (3.15V / 4.65V)
- ❑ Low voltage detection at V_S
- ❑ Wake-up by K-BUS traffic and start-up capable independent of EN voltage level
- ❑ Universal comparator with an input voltage range $-24\text{V} \dots 30\text{V}$ and digital output
- ❑ Load dump protected (40V)

Pin Diagram

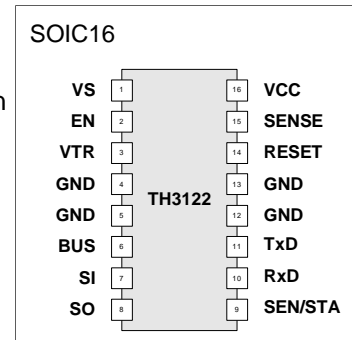

Ordering Information

Part No.	Temperature Code	Package Code
TH3122	K (-40°C to 125°C)	DF (SOIC16, 300mil)

General Description

The TH3122 consists of a low drop voltage regulator 5V/100mA and a K-Bus transceiver. The transceiver is suitable for K-Bus systems conform to ISO 9141.

The combination of voltage regulator and bus transceiver in combination with the monitoring

functions make it possible to develop simple, but powerful and cheap nodes in K-Bus systems.

The wide output current area and the configurable reset time and reset voltage works together with many different microcontrollers.

Functional Diagram

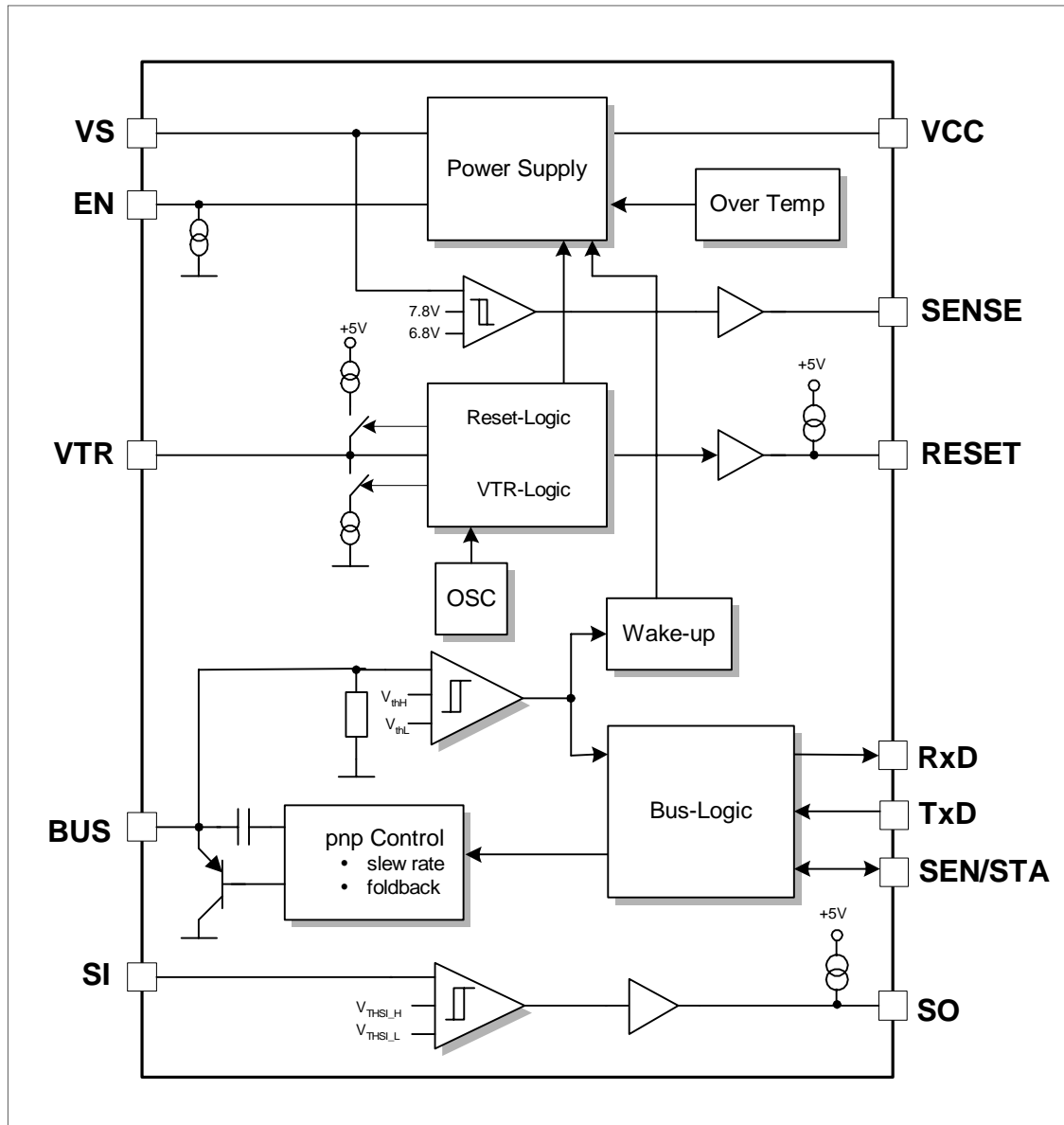

Figure 1 - Block Diagram

Functional Description

The TH3122 consists of a voltage regulator 5V/100mA and a K-Bus transceiver, which is a bi-directional bus interface device for data transfer between K-Bus and the K-Bus protocol controller.

Also integrated into the transceiver are a voltage and time controlled reset management, power down, wake up function and a universal comparator for extended applications.

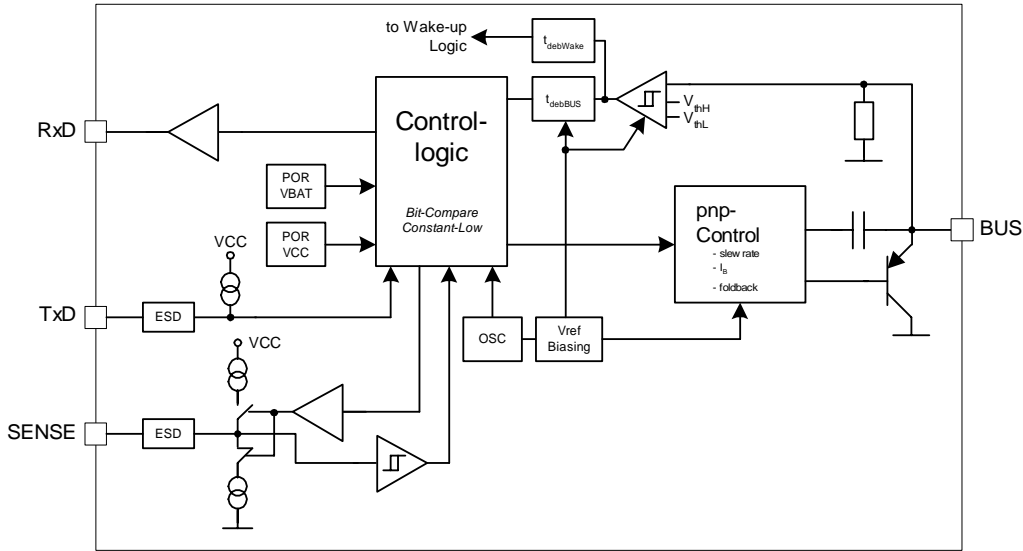

Figure 2 - Block Diagram K-Bus Transceiver

K-BUS Interface

The BUS Interface builds the connection between the serial 5V bus line of the protocol controller and the 12V K-Bus line.

The transceiver consists of a pnp-driver with slew rate control and fold-back characteristic and contains also in the receiver a high voltage comparator followed by a debouncing unit.

electromagnetic emission of the bus line, the TH3122 has an integrated slew rate control.

Receive Mode

The data at the pin BUS will be transferred to the pin RxD. Short spikes on the bus signal are suppressed by the implemented debouncing circuit.

Transmit Mode

During the transmission the data at the pin TxD will be transferred to the pin BUS. To minimize the

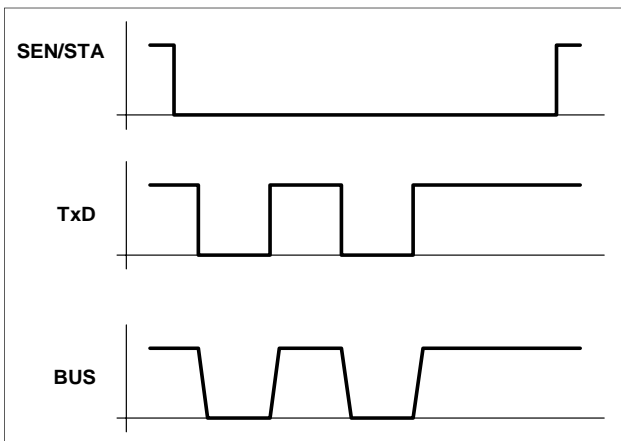

Figure 3 - Transmit Mode Pulse Diagram

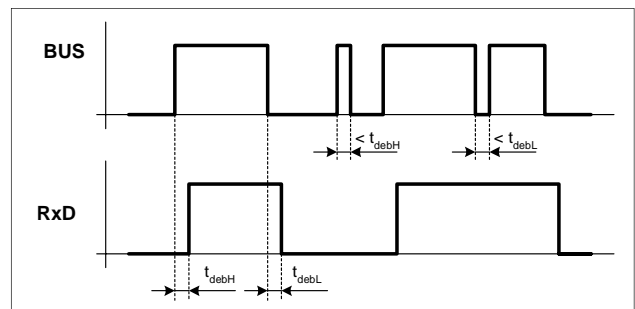

Figure 4 - Receive Mode Pulse Diagram

Bit Compare

If the signals at the pin TxD and the pin BUS within a specified time t_{bc} are not identical, the transmission will be interrupted.

If both signals at TxD and BUS are "High" within the time t_{ena} the transmission will be enabled. The bit-compare-function is active when the pin SEN/STA is open (not overwritten).

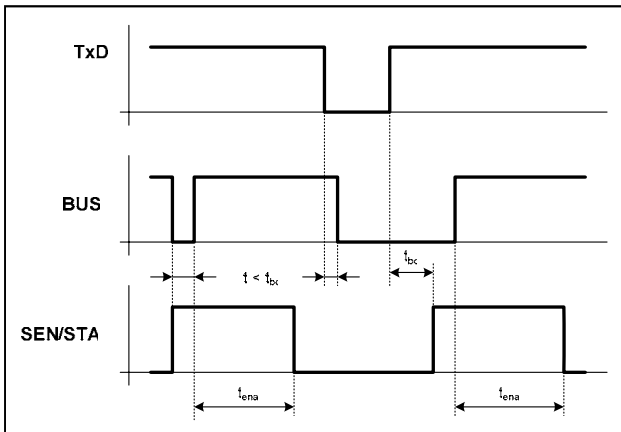

Figure 5 - Bit Compare Pulse Diagram

SEN/STA

The pin SEN/STA is bidirectional. Used as an output the pin indicates whether the transmit-path is enabled or disabled:

- SEN/STA = "0"
transmission path is enabled
- SEN/STA = "1"
transmission path is disabled

Using this pin as an input the transmission path can be overwritten (independent of bit-compare and constant-low function):

- SEN/STA="0"
forcing the transmission path free
- SEN/STA="1"
disable the transmission path

Constant Low Switch Off

A falling edge at pin TxD (from "1" to "0") starts the internal constant low timer (SEN/STA open).

If the low level "0" is valid for the time t_{low} the transmission unit of the TH3122 will be disabled.

The receive unit is still active. A high level "1" at TxD with a minimum pulse width of t_{rec} resets the constant low timer.

Transmitting is not possible until TxD and BUS is High for the time t_{ena} .

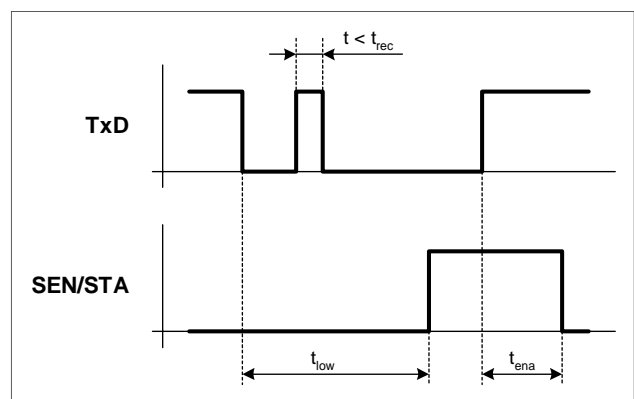

Figure 6 - Constant Low Pulse Diagram

Linear Regulator and Controlling Functions

Regulator

The TH3122 has an integrated linear regulator with an output voltage of $5V \pm 2\%$ and an output current of max. 100mA. The regulator is switched on or off with a signal on the EN pin or wakes up with a BUS signal.

Initialization

The initialization is started if the power supply is switched on, or after the temperature limitation has switched off the regulator or in case of BUS traffic (wake up).

If the V_{CC} voltage level is higher than V_{RESEIN} , the reset time t_{RES} is started. This reset time is determined by the

voltage level on the VTR pin (see table VTR Programming). After t_{RES} a rising edge on the RESET output is generated (see figure 7 - Initialization).

The regulator is active and can only be switched off with a falling edge on EN. The regulator remains with EN=high in active mode and therefore the V_{CC} voltage is also active.

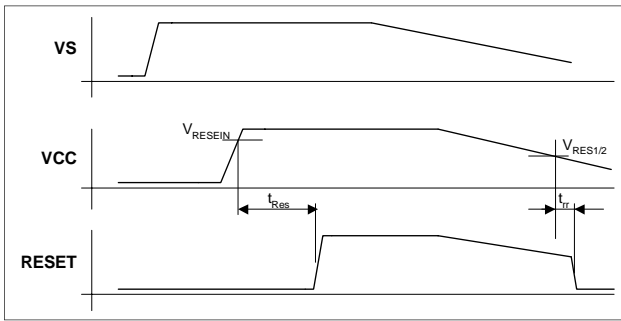

Figure 7 - Initialization

The input EN has an internal pull down resistor. If EN=high, the internal pull down current is switched off to minimize the quiescent current.

RESET Output

The RESET output is switched from low to high if V_S is switched on and $V_{CC} > V_{RESEIN}$ after the time t_{RES} .

If the voltage V_{CC} drops below V_{RES1} or V_{RES2} then the RESET output is switched from high to low after the time t_{tr} has been reached.

The voltage level for V_{RES1} and V_{RES2} and the corresponding times t_{RES} can be programmed via the analogue input VTR.

Wake up with BUS traffic

If the regulator is put in standby mode it can be woken up with the BUS interface. Every pulse on the BUS (high pulse or low pulse) with a pulse width of min. 45 μ s will switch on the regulator.

After the BUS has woken up the regulator, it can only be switched off with a high level followed by a low level on the EN pin.

Reset Programming on VTR

With the VTR pin the reset switches off levels and delay time can be programmed.

The voltage on VCC influences the reset function.

VTR-Mode	V_{RES}	t_{RES}
VTR = GND	$V_{RES} = V_{RES1} = 3.15V$	100ms
VTR = VCC	$V_{RES} = V_{RES2} = 4.65V$	100ms
VTR with $R \geq 50k \Omega$ to GND	$V_{RES} = V_{RES1} = 3.15V$	15ms
VTR with $R \geq 50k \Omega$ to VCC	$V_{RES} = V_{RES2} = 4.65V$	15ms

VTR-Programming

The voltage on VTR input is read out if the voltage at this pin is higher than V_{RESEIN} . This value defines the reset switch off voltage V_{RES} . With the next oscillator cycle it switches on the pull up current source if VTR=low or the pull down current source if VTR=high. The sources are active for one oscillator cycle. The level changes during this procedure on VTR, which depends on the external pull up or pull down resistors control the reset time t_{RES} .

Temperature Limitation

If the junction temperature $150^\circ C < T_j < 170^\circ C$ the over temperature recognition will be active and the regulator voltage and the BUS driver will be switched off. After T_j falls below $140^\circ C$ the TH3122 will be initialized, independently of the voltage levels on EN and BUS.

The function of the TH3122 is possible between T_{Amax} and the switch off temperature, but small parameter differences can appear.

Low Voltage Detection V_S

Low voltage on V_S is monitored on SENSE output.

If V_S has reached the level of $V_S = 6.8V$ then the SENSE output generates low level. The normal operating range is $V_S > 7.8V$ and the SENSE output generates a high level.

Universal Comparator

The TH3122 consist of a universal comparator for general use. The positive input of this comparator is connected to the pin SI. The input voltage range of SI is $0V \dots V_S$. The input voltage is compared with a fixed reference voltage at high or low level and the comparator output SO drives a 5V digital signal.

Application Hints

Operating during Disturbances

The absence of V_S , V_{CC} or GND connection or ground shift either alone or in any combination, do not influence or disturb the communication between other bus nodes.

Undervoltage

The reset unit secures the correct behavior of the driver during undervoltage. The inputs have pull-up or pull-down characteristics and have therefore defined voltage levels.

With $4.5V \leq V_{CC} \leq 5.25V$ the bus connection operates within the correct parameters .

If $V_{RES1} \leq V_{CC} \leq 4.5V$ the TxD signal is transmitted to the bus. The receive mode is also active.

If $V_{CC} < V_{RES1}$ the bus driver is tristate.

SENSE and SO output the correct signal if $V_{CC} > V_{RES}$. The specified values of the input voltages on SO can't guaranteed.

Regulator Circuitry

The choice and dimension of the capacitor on VCC is determined by application point of view. Important parameters are the current difference on load changes and the maximum short time voltage drop.

The VCC pin must be connected to a min. $2\mu F$ capacitor for stable operating of the regulator in the whole operating range.

Short Circuit Proof

All in- and outputs are short circuit proof to battery and ground. A thermal shut down circuit prevents VCC and BUS from any damage.

Baud Rate

The TH3122 has a maximum Baud rate of 9600 Baud ($C_{BUS} < 25nF$, $R_{PU} > 400\Omega$).

Application Circuitry

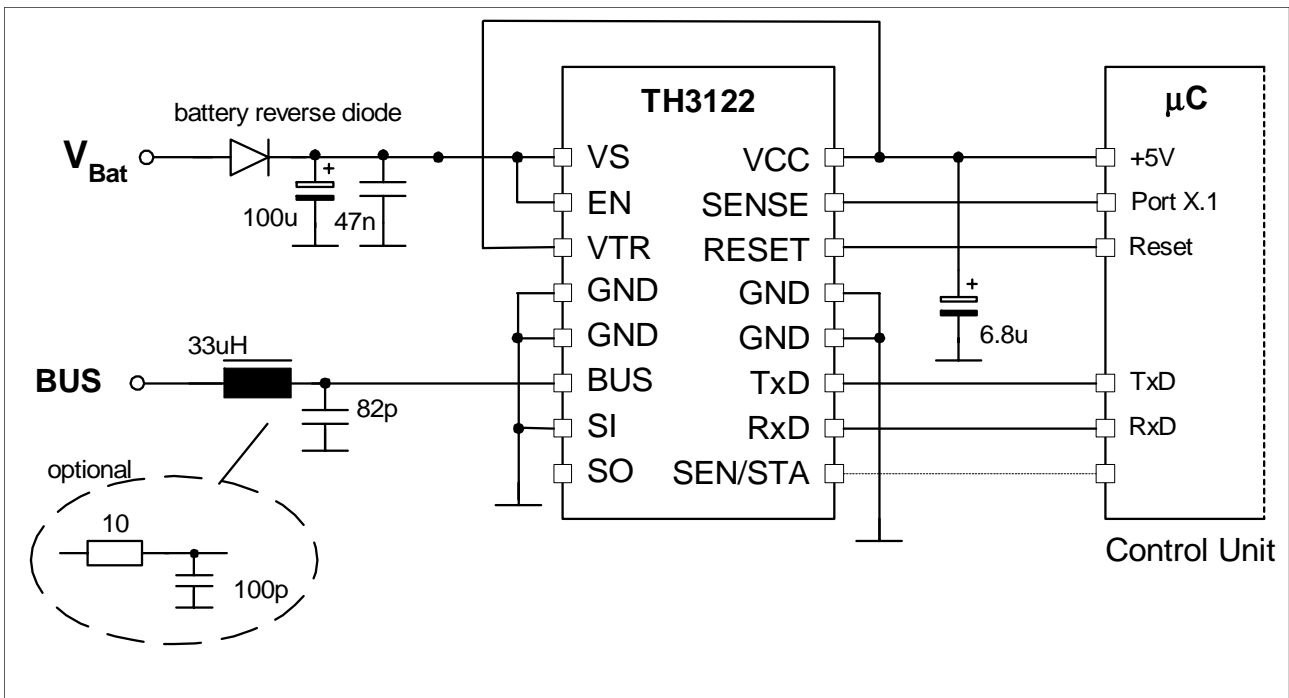

Figure 8 - Application Circuit

There should be used an LC-Filter to minimize the influence of EMI on the BUS lines.

Electrical Specification

All voltages are referenced to ground (GND). Positive currents flow into the IC. The absolute maximum ratings given in the table below are limiting values that do not lead to a permanent damage of the device but exceeding

any of these limits may do so. Long term exposure to limiting values may affect the reliability of the device. Reliable operation of the TH3122 is only specified within the limits shown in "Operating conditions".

Operating Conditions

Parameter	Symbol	Min	Max	Unit
Battery voltage	V_S	5.25	16	V
Supply voltage	V_{CC}	4.75	5.25	V
Operating ambient temperature	T_A	-40	+125	°C
Junction temperature ^[1]	T_J		+150	°C

Absolute Maximum Ratings

Parameter	Symbol	Condition	Min	Max	Unit
Supply voltage at V_S ^[2]	V_S		-1.0	16	V
		$T \leq 1\text{min}$	-	30	
		$T \leq 500\text{ms}$	-	40	
Input voltage at pin BUS ^[2]	V_{INBUS}		-24	30	V
		$T \leq 500\text{ms}$	-	40	
Difference V_S-V_{CC}	V_{S-VCC}		-0.3	40	V
Input voltage at pin EN and SI	V_{INENSI}		-0.3	$V_S+0.3$	V
Input voltage at pin VTR, TxD, SEN/STA, SO, RESET, SENSE	V_{IN}		-0.3	$V_{CC}+0.3$	V
Input current at pin EN, VTR, SI, SO, SEN/STA, TxD, RxD, RESET, SENSE	I_{IN}		-25	25	mA
Input current for short circuit of pin V_S and V_{CC}	I_{Short}		-500	500	mA
Power dissipation	P_0	Internal limited ^[3] ^[4]			mW
Thermal resistance from junction to ambient	R_{THJA}			50	K/W
Junction temperature ^[4]	T_J			150	°C
Storage temperature	T_{STG}		-55	150	°C

^[1] Junction temperature is defined in IEC 747-1

^[2] The current and voltage values are valid independent from each other.

^[3] The maximum power dissipation is defined by the ambient temperature and the thermal resistance. It can be calculated with

$P_0 = (V_S - V_{CC}) \cdot I_{VCC} + P_{BUS}$. P_{BUS} is the BUS driver output with normally $\leq 25\text{mW}$

^[4] see over temperature protection

Static Characteristics

($V_S = 5.25$ to $16V$, $V_{CC} = 4.75$ to $5.25V$, $T_A = -40$ to $+125^\circ C$, unless otherwise specified)

Parameter	Symbol	Condition	Min	Typ	Max	Unit
Linear Regulator						
Output voltage VCC	V_{CCn}	$5.5V \leq V_S \leq 16V$ $T_A = 25^\circ C$	4.95	5.0	5.05	V
	V_{CCt}	$5.5V \leq V_S \leq 16V$	4.90	5.0	5.10	V
	V_{CCh}	$V_{SUP} > 16V$	4.95	5.0	5.25	V
	V_{CCl}	$3.3V < V_S < 5.5V$	$V_S - V_D$		5.1	V
Supply current, „normal mode“	I_{Snl}	$V_{EN} = V_S = 12V$, Pins 8-11, 14-16 open			100	μA
Supply current, „sleep mode“	I_{Ssleep}	$V_{EN} = 0V$, V_{CC} switched off		35	50	μA
Drop-out voltage	V_D	$V_S \geq 4.0V$, $I_{VCC} = 25mA$			200	mV
		$V_S \geq 4.0V$, $I_{VCC} = 100mA$			400	mV
		$V_S \geq 3.3V$, $I_{VCC} = 20mA$			600	mV
Output current VCC	I_{VCC}	$V_S \geq 3.0V$	100			mA
Current limitation VCC	I_{LVCC}	$V_S > 0V$			300	mA
Load capacity	C_{load}	$ESR \leq 5\Omega$	2			μF
Power-on-reset threshold “V _{CC} on”	V_{RESEIN}	referred to V_{CC} , $V_S > 4.6V$	4.5	4.65	4.8	V
Power-on-reset threshold “V _{CC} off”	V_{RES2}	$V_{TR} = High$, $V_S > 0V$	4.5	4.65	4.8	V
	V_{RES1}	$V_{TR} = Low$, $V_S > 0V$	3.0	3.15	3.3	
SENSE-Output						
VS - threshold low at SENSE	V_{SENL}		6.8			V
VS - threshold high an SENSE	V_{SENH}				7.8	V
Hysteresis SENSE	V_{SENHYS}		100			mV
Output voltage low	V_{OL}	$I_{OUT} = 1mA$			0.8	V
Output voltage high	V_{OH}	$I_{OUT} = -1mA$	$V_{CC} - 0.8$			V
Enable-Input EN						
Input voltage low	V_{ENL}		-0.3		1.75	V
Input voltage high	V_{ENH}		2.5		$V_S + 0.3$	V
Hysteresis	V_{ENHYS}		100			mV
Pull-down current EN	I_{pdEN}	$V_{EN} > V_{ENH}$	1.8	4.0	7.5	μA
		$V_{EN} < V_{ENL}$	70	100	130	μA
Output RESET						
Output voltage low	V_{OL}	$I_{OUT} = 1mA$, $V_{SUP} > 5.5V$			0.8	V
		10 k Ω RESET to VCC			0.2	V
Pull-up current	I_{pu}		-500	-375	-250	μA

Static Characteristics (continued)

Parameter	Symbol	Condition	Min	Typ	Max	Unit
Comparator SI, SO						
Threshold low SI	V_{IL}		1.05	1.16		V
Threshold High SI	V_{IH}			1.21	1.4	V
Hysteresis	V_{HYS}		30			mV
Output voltage low at SO	V_{OL}	$I_{OUT} = 1 \text{ mA}, V_S > 5.5 \text{ V}$			0.8	V
		$10 \text{ k}\Omega \text{ SO to VCC}, V_{CC} > 3.3\text{V}$			0.4	V
Pull-up current at SO	I_{pu}		-500	-375	-250	μA
Input VTR						
Threshold low	V_{TRL}		0.15	0.25		V_{CC}
Threshold high	V_{TRH}			0.75	0.85	V_{CC}
Output current low	I_{OL}	$V_{CC} > 3.3 \text{ V}$	160	230	300	μA
Output current high	I_{OH}		-300	-230	-160	μA
K-Bus-Interface						
Power-on-reset threshold	V_{POR}	$V_{POR} = V_{RES1}$	3.0	3.15	3.3	V
Pull-up current TxD	I_{pu}		-500	-375	-250	μA
Pull-down current SEN/STA	I_{pdSEN}		250	375	500	μA
Pull-up current SEN/STA	I_{puSEN}		-500	-375	-250	μA
Input voltage low TxD, SEN/STA	V_{IL}				0.25	V_{CC}
Input voltage high TxD, SEN/STA	V_{IH}		0.75			V_{CC}
Input voltage low BUS	V_{IL}				0.45	V_S
Input voltage high BUS	V_{IH}		0.55			V_S
Hysteresis BUS	V_{HYS}			50		mV
Input resistance BUS	R_{INBUS}	$0 \leq V_{BUS} \leq 40 \text{ V}$	400	600	1500	k Ω
		$0 \leq V_{BUS} \leq 40 \text{ V}$ $T_A \leq 125 \text{ }^\circ\text{C}$			1300	
		$V_{BUS} = -25\text{V}$ $T_A \leq 125 \text{ }^\circ\text{C}$	60			
Output voltage BUS	V_{BUS}	$V_S = 12\text{V}, \text{SENSE} = \text{low}$ $I_{OUT} = 40 \text{ mA}$			1.2	V
		$V_S = 12\text{V}, \text{SENSE} = \text{low}$ $I_{OUT} = 25 \text{ mA}$			1.0	
Current limitation BUS	I_{LIM}	$V_{BUS} > 2.5\text{V}$	40		100	mA
Output voltage low RxD	V_{OL}	$I_{OUT} = 1 \text{ mA}$			0.8	V
Output voltage high RxD	V_{OH}	$I_{OUT} = -1\text{mA}$	$V_{CC}-0.8$			V

Dynamic Characteristics

($5.25V \leq V_S \leq 16V$, $4.75V \leq V_{CC} \leq 5.25V$, $-40^\circ C \leq T_A \leq 125^\circ C$, unless otherwise specified)

Parameter	Symbol	Condition	Min	Typ	Max	Unit
RESET						
Reset time	t_{Res}	$R_{VTR} < 1\text{ k}\Omega$	70	100	140	ms
		$R_{VTR} > 45\text{ k}\Omega$	10	15	20	ms
Reset rising time	t_{rr}		3.0	6.5	10	$\mu\text{ s}$
K-Bus-Interface						
Slew rate BUS falling edge	dV/dT_{fall}		-2.2	-1.6	-1.0	$V/\mu\text{ s}$
Slew rate BUS rising edge	dV/dT_{rise}		1.0	1.6	2.2	
Symmetry of Slew rate BUS	dV/dT_{sym}				0.3	$V/\mu\text{ s}$
Debouncing time BUS	t_{debBUS}	High pulse or low pulse	1.5	2.8	4.0	$\mu\text{ s}$
Symmetry of debouncing BUS	t_{debsym}				0.5	$\mu\text{ s}$
Propagation delay TxD -> RxD	t_{pd}				20	$\mu\text{ s}$
Symmetry of propagation delay TxD -> RxD	t_{pdsym}				3.5	$\mu\text{ s}$
Bit compare time BUS, SENSE, TxD	t_{bc}		35	52	70	$\mu\text{ s}$
Recovery time BUS, TxD	t_{rec}		30	50	75	$\mu\text{ s}$
Inhibit time for transmit BUS, TxD	t_{ena}		0.92	1.33	1.8	ms
Constant low switch off BUS, TxD	t_{low}		3	6	12	ms
Oscillator frequency	f_{OSC}		8	12	15	kHz
Debouncing time TxD	t_{deb}		0.6	1.0	1.5	$\mu\text{ s}$
Debouncing time EN	t_{deb}		200			ns
Wake-up debouncing BUS	$t_{debWake}$		25	45	90	$\mu\text{ s}$
Propagation delay SI -> SO	t_{pdcomp}		4		11	$\mu\text{ s}$
Debouncing VS-SENSE	t_{deb}		10	17	25	$\mu\text{ s}$

Pin Description

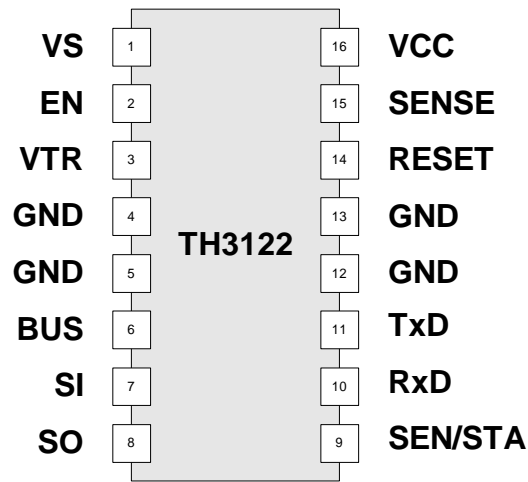

Pin	Name	I/O	Function
1	VS		Supply voltage
2	EN	I	Enable Input voltage regulator, HV-pull-down-Input, High-active
3	VTR	I	Analogue Input - definition of reset time und Reset voltage level
4	GND		Ground
5	GND		Ground
6	BUS	I/O	Bi-directional bus line
7	SI	I	Comparator Input, HV-Input
8	SO	O	5V-Comparator Output
9	SEN/STA	I/O	Send status
10	RxD	O	Receive Output, 5V-push-pull
11	TxD	I	5V-Transmit Input, pull-up-Input
12	GND		Ground
13	GND		Ground
14	RESET	O	5V-output reset, active low
15	SENSE	O	5V-output of VS-Monitoring
16	VCC	O	Regulator output 5V/100mA

Mechanical Specifications

DF (SOIC16) Package Dimensions

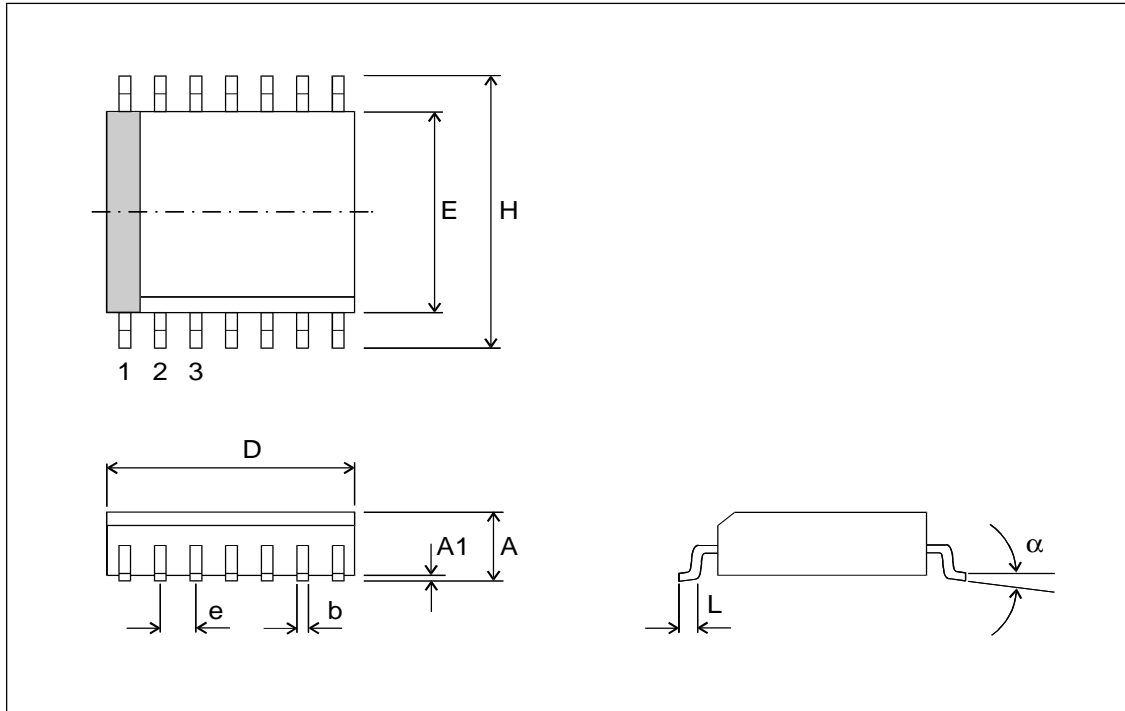

Small Outline Integrated Circuit (SOIC), DF (SOIC 16, 300 mil)

All Dimension in mm, coplanarity < 0.1 mm									
	D	E	H	A	A1	e	b	L	α
min	10.1	7.40	10.00	2.35	0.10	1.27	0.33	0.40	0°
max	10.5	7.60	10.65	2.65	0.30	1.27	0.51	1.27	8°
All Dimension in inch, coplanarity < 0.004"									
min	0.398	0.291	0.394	0.093	0.004	0.050	0.013	0.016	0°
max	0.413	0.299	0.419	0.104	0.012	0.050	0.020	0.050	8°

Assembly Information

This Melexis device is classified and qualified regarding soldering technology, solderability and moisture sensitivity level, as defined in this specification, according to following test methods:

IPC/JEDEC J-STD-020

Moisture/Reflow Sensitivity Classification For Nonhermetic Solid State Surface Mount Devices
(classification reflow profiles according to table 5-2)

EIA/JEDEC JESD22-A113

Preconditioning of Nonhermetic Surface Mount Devices Prior to Reliability Testing
(reflow profiles according to table 2)

CECC00802

Standard Method For The Specification of Surface Mounting Components (SMDs) of Assessed Quality

EIA/JEDEC JESD22-B106

Resistance to soldering temperature for through-hole mounted devices

EN60749-15

Resistance to soldering temperature for through-hole mounted devices

MIL 883 Method 2003 / EIA/JEDEC JESD22-B102

Solderability

For all soldering technologies deviating from above mentioned standard conditions (regarding peak temperature, temperature gradient, temperature profile etc) additional classification and qualification tests have to be agreed upon with Melexis.

The application of Wave Soldering for SMD's is allowed only after consulting Melexis regarding assurance of adhesive strength between device and board.

Based on Melexis commitment to environmental responsibility, European legislation (Directive on the Restriction of the Use of Certain Hazardous substances, RoHS) and customer requests, Melexis has installed a roadmap to qualify their package families for lead free processes also.

Various lead free generic qualifications are running, current results on request.

For more information on Melexis lead free statement see quality page at our website:
<http://www.melexis.com/html/pdf/MLXleadfree-statement.pdf>

ESD Precautions

Electronic semiconductor products are sensitive to Electro Static Discharge (ESD).

Always observe Electro Static Discharge control procedures whenever handling semiconductor products.

Disclaimer

Devices sold by Melexis are covered by the warranty and patent indemnification provisions appearing in its Term of Sale. Melexis makes no warranty, express, statutory, implied, or by description regarding the information set forth herein or regarding the freedom of the described devices from patent infringement. Melexis reserves the right to change specifications and prices at any time and without notice. Therefore, prior to designing this product into a system, it is necessary to check with Melexis for current information. This product is intended for use in normal commercial applications. Applications requiring extended temperature range, unusual environmental requirements, or high reliability applications, such as military, medical life-support or life-sustaining equipment are specifically not recommended without additional processing by Melexis for each application.

The information furnished by Melexis is believed to be correct and accurate. However, Melexis shall not be liable to recipient or any third party for any damages, including but not limited to personal injury, property damage, loss of profits, loss of use, interrupt of business or indirect, special incidental or consequential damages, of any kind, in connection with or arising out of the furnishing, performance or use of the technical data herein. No obligation or liability to recipient or any third party shall arise or flow out of Melexis' rendering of technical or other services.

© 2002 Melexis NV. All rights reserved.

For the latest version of this document, go to our website at:

www.melexis.com

Or for additional information contact Melexis Direct:

Europe and Japan:

Phone: +32 13 67 04 95
E-mail: sales_europe@melexis.com

All other locations:

Phone: +1 603 223 2362
E-mail: sales_usa@melexis.com

ISO/TS 16949 and ISO14001 Certified