

TIP140-141-142
TIP145-146-147

POWER DARLINGTONS

DESCRIPTION

The TIP140, TIP141, TIP142 are silicon epitaxial-base NPN transistors in monolithic Darlington configuration and are mounted in SOT-93 plastic package. They are intended for use in power linear and switching applications. The complementary PNP types are the TIP145, TIP146, TIP147 respectively.

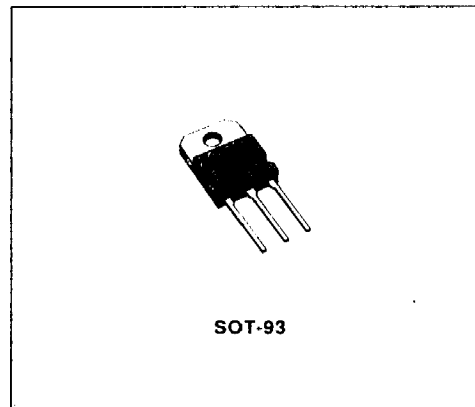

INTERNAL SCHEMATIC DIAGRAMS

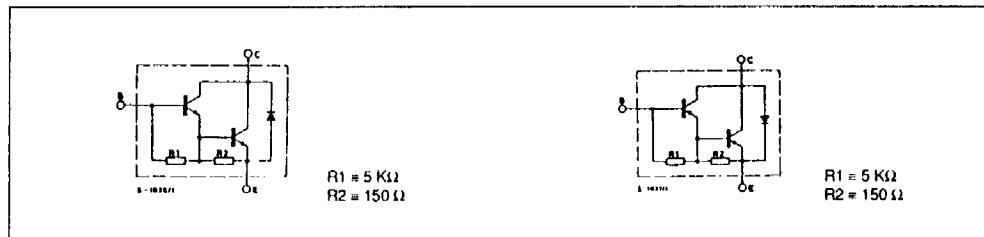

ABSOLUTE MAXIMUM RATINGS

Symbol	Parameter	NPN *PNP	Value			Unit
			TIP140 TIP145	TIP141 TIP146	TIP142 TIP147	
V _{CB0}	Collector-base Voltage (I _E = 0)		60	80	100	V
V _{CE0}	Collector-emitter Voltage (I _B = 0)		60	80	100	V
V _{EB0}	Emitter-base Voltage (I _C = 0)		5			V
I _C	Collector Current		10			A
I _{CM}	Collector Peak Current (repetitive)		20			A
I _B	Base Current		0.5			A
P _{tot}	Total Power Dissipation at T _{case} ≤ 25 °C		125			W
T _{stg}	Storage Temperature		- 65 to 150			°C
T _j	Junction Temperature		150			°C

*For PNP types voltage and current values are negative.

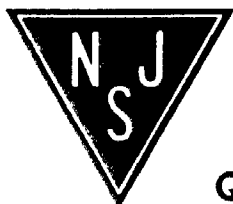

NJ Semi-Conductors reserves the right to change test conditions, parameter limits and package dimensions without notice. Information furnished by NJ Semi-Conductors is believed to be both accurate and reliable at the time of going to press. However, NJ Semi-Conductors assumes no responsibility for any errors or omissions discovered in its use. NJ Semi-Conductors encourages customers to verify that datasheets are current before placing orders.

THERMAL DATA

$R_{th(j-case)}$	Thermal Resistance Junction-case	Max	1	°C/W
------------------	----------------------------------	-----	---	------

ELECTRICAL CHARACTERISTICS ($T_{case} = 25\text{ °C}$ unless otherwise specified)

Symbol	Parameter	Test Conditions	Min.	Typ.	Max.	Unit
I_{CBO}	Collector Cutoff Current ($I_E = 0$)	for TIP140/5 $V_{CB} = 60\text{ V}$ for TIP141/6 $V_{CB} = 80\text{ V}$ for TIP142/7 $V_{CB} = 100\text{ V}$			1 1 1	mA mA mA
I_{CEO}	Collector Cutoff Current ($I_B = 0$)	for TIP140/5 $V_{CB} = 30\text{ V}$ for TIP141/6 $V_{CE} = 40\text{ V}$ for TIP142/7 $V_{CE} = 50\text{ V}$			2 2 2	mA mA mA
I_{EBO}	Emitter Cutoff Current ($I_C = 0$)	$V_{EBO} = 5\text{ V}$			2	mA
$V_{CE(sus)}$ *	Collector-emitter Sustaining Voltage ($I_B = 0$)	$I_C = 30\text{ mA}$	for TIP140/5 60 for TIP141/6 80 for TIP142/7 100			V V V
$V_{CE(sat)}$ *	Collector-emitter Saturation Voltage	$I_C = 5\text{ A}$ $I_C = 10\text{ A}$	$I_B = 10\text{ mA}$ $I_B = 40\text{ mA}$		2 3	V V
V_{BE} *	Base-emitter Voltage	$I_C = 10\text{ A}$	$V_{CE} = 4\text{ V}$		3	V
h_{FE} *	DC current Gain	$I_C = 5\text{ A}$ $I_C = 10\text{ A}$	$V_{CE} = 4\text{ V}$ $V_{CE} = 4\text{ V}$	1000 500		
t_{on}	Turn-on Time	$I_C = 10\text{ A}$	$I_{B1} = 40\text{ mA}$		0.9	μs
t_{off}	Turn-off Time	$I_{B2} = -40\text{ mA}$	$R_L = 3\ \Omega$		4	μs

* Pulsed : pulse duration - 200 μs , duty cycle - 1.5 %.
For PNP devices voltage and current values are negative.

MECHANICAL DATA

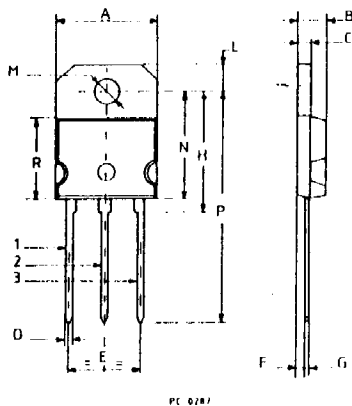

	DIMENSIONS			
	mm		inches	
	min	max	min	max
A	14.7	15.2	0.578	0.598
B	4.7	4.9	0.185	0.193
C	1.9	2.1	0.075	0.082
D	1.1	1.3	0.043	0.051
E	10.8	11.1	0.425	0.437
F	2.5 typ		0.098 typ	
G	0.5	0.78	0.019	0.030
H	18 typ		0.708 typ	
L	3.95	4.15	0.155	0.163
M	4	4.1	0.157	0.161
N	—	16.2	—	0.637
P	31 typ		1.220 typ	
R	—	12.2	—	0.480

pin 1: Base - pin 2: Collector - pin 3: Emitter

