

**SPTECH Silicon NPN Darlington Power Transistor**

**TIP142**

**DESCRIPTION**

- High DC Current Gain-  
:  $h_{FE} = 1000(\text{Min}) @ I_C = 5A$
- Collector-Emitter Sustaining Voltage-  
:  $V_{CEO(\text{SUS})} = 100V(\text{Min})$
- Complement to Type TIP147

**APPLICATIONS**

- Designed for general purpose amplifier and low frequency switching applications.

**ABSOLUTE MAXIMUM RATINGS( $T_a=25^\circ\text{C}$ )**

SYMBOL	PARAMETER	VALUE	UNIT
$V_{CBO}$	Collector-Base Voltage	100	V
$V_{CEO}$	Collector-Emitter Voltage	100	V
$V_{EBO}$	Emitter-Base Voltage	5	V
$I_C$	Collector Current-Continuous	10	A
$I_{CM}$	Collector Current-Peak	15	A
$I_B$	Base Current- Continuous	0.5	A
$P_C$	Collector Power Dissipation @ $T_C=25^\circ\text{C}$	125	W
$T_j$	Junction Temperature	150	$^\circ\text{C}$
$T_{stg}$	Storage Temperature Range	-65~150	$^\circ\text{C}$

**THERMAL CHARACTERISTICS**

SYMBOL	PARAMETER	MAX	UNIT
$R_{th\ j-c}$	Thermal Resistance, Junction to Case	1.0	$^\circ\text{C}/\text{W}$
$R_{th\ j-a}$	Thermal Resistance, Junction to Ambient	35.7	$^\circ\text{C}/\text{W}$

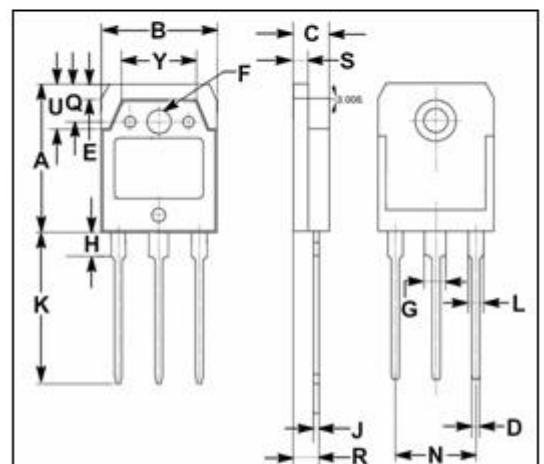
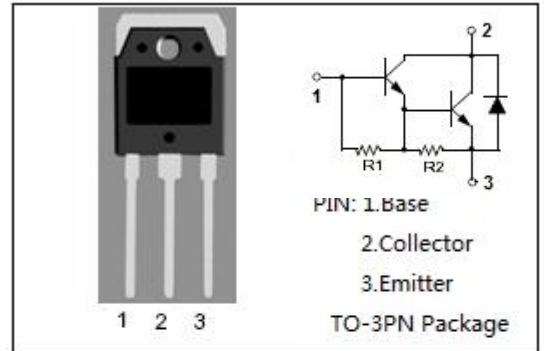

DIM	mm	
	MIN	MAX
A	19.60	20.30
B	15.50	15.70
C	4.70	4.90
D	0.90	1.10
E	1.90	2.10
F	3.40	3.60
G	2.90	3.20
H	3.20	3.40
J	0.595	0.605
K	19.80	20.70
L	1.90	2.20
N	10.89	10.91
Q	4.90	5.10
R	3.35	3.45
S	1.995	2.100
U	5.90	6.20
Y	9.90	10.10

**ELECTRICAL CHARACTERISTICS**

$T_C=25^{\circ}\text{C}$  unless otherwise specified

SYMBOL	PARAMETER	CONDITIONS	MIN	TYP.	MAX	UNIT
$V_{CE(sus)}$	Collector-Emitter Sustaining Voltage	$I_C = 30\text{mA}, I_B = 0$	100			V
$V_{CE(sat)-1}$	Collector-Emitter Saturation Voltage	$I_C = 5\text{A}, I_B = 10\text{mA}$			2.0	V
$V_{CE(sat)-2}$	Collector-Emitter Saturation Voltage	$I_C = 10\text{A}, I_B = 40\text{mA}$			3.0	V
$V_{BE(sat)}$	Base-Emitter Saturation Voltage	$I_C = 10\text{A}, I_B = 40\text{mA}$			3.5	V
$V_{BE(on)}$	Base-Emitter On Voltage	$I_C = 10\text{A}; V_{CE} = 4\text{V}$			3.0	V
$I_{CBO}$	Collector Cutoff current	$V_{CB} = 100\text{V}, I_E = 0$			1	mA
$I_{CEO}$	Collector Cutoff current	$V_{CE} = 50\text{V}, I_B = 0$			2	mA
$I_{EBO}$	Emitter Cutoff Current	$V_{EB} = 5\text{V}; I_C = 0$			2	mA
$h_{FE-1}$	DC Current Gain	$I_C = 5\text{A}; V_{CE} = 4\text{V}$	1000			
$h_{FE-2}$	DC Current Gain	$I_C = 10\text{A}; V_{CE} = 4\text{V}$	500			

Switching Times

$t_d$	Delay Time	$V_{CC} = 30\text{V}, I_C = 5.0\text{A},$ $I_B = 20\text{mA};$ Duty Cycle $\leq 20\%$ $I_{B1} = I_{B2},$ $R_C \text{ \& } R_B \text{ Varied},$ $T_J = 25^{\circ}\text{C}$		0.15		$\mu\text{s}$
$t_r$	Rise Time			0.55		$\mu\text{s}$
$t_{stg}$	Storage Time			2.5		$\mu\text{s}$
$t_f$	Fall Time			2.5		$\mu\text{s}$

**SPTECH Silicon NPN Darlington Power Transistor TIP142**

