

LOW DROPOUT VOLTAGE REGULATOR

FEATURES

- High Precision Output Voltage ($\pm 1.5\%$ or ± 50 mV)
- Active High On/Off Control
- Very Low Dropout Voltage ($V_{\text{DROP}} = 103$ mV at 100 mA)
- Very Good Stability: $CL = 0.22 \mu\text{F}$ is Stable For Any Type Capacitor with $V_{\text{OUT}} \geq 1.8$ V ($I_{\text{OUT}} > 0.5$ mA)
- Excellent Ripple Rejection Ratio (80 dB @ 1 kHz)
- Very Low Quiescent Current ($I_{\text{Q}} = 72 \mu\text{A}$ at $I_{\text{OUT}} = 0$ mA)
- Peak Output Current is 370 mA
- SOT23-5 Package
- Very Low Noise
- Wide Operating Voltage Range (1.8 V ~ 14 V)
- Reverse Bias and Overcurrent Protection
- Built-in Thermal Shutdown
- Short Circuit Protection

DESCRIPTION

The TK717xxS is a low dropout linear regulator with a built-in electronic switch. The internal switch can be controlled by TTL or CMOS logic levels. The device is in the "on" state when the control pin is pulled to a logic high level. An external capacitor can be connected to the noise bypass pin to lower the output noise level to $30 \mu\text{V}_{\text{RMS}}$.

An internal PNP pass transistor is used to achieve a low dropout voltage of 65 mV (typ.) at 50 mA load current. The TK717xxS has a low quiescent current of $72 \mu\text{A}$ (typ.) at no load and 0.8 mA at 50 mA load. In the "off" state, the output impedance becomes very low, quickly discharging the output capacitor. The internal thermal shutdown circuitry limits the junction temperature to 150 °C. The load current is internally monitored and the device will shut down in the presence of a short circuit or overcurrent condition at the output.

APPLICATIONS

- Battery Powered Systems
- Measurement Systems
- Mobile Communications Systems
- Cordless Phone, PHS, GSM, CDMA
- Industrial Equipment
- Personal Computers, Barcode Readers

The TK717xxS circuit features very high stability in both DC and AC. An output capacitor of $0.22 \mu\text{F}$ provides stable operation for $V_{\text{OUT}} \geq 2.0$ V. Any type of capacitor can be used; however, the larger this capacitor is, the better the overall characteristics are. The ripple rejection ratio is 84 dB at 400 Hz, and 80 dB at 1 kHz.

The TK717xxS is available in a SOT23-5 surface mount package.

ORDERING INFORMATION

TK717 □□ S □ L

Voltage Code	Tape/Reel Code
Package Code	Temp. Code

VOLTAGE CODE: Refer to Table 1	PACKAGE CODE: S: SOT23-5	TAPE/REEL CODE: L: Tape Left Reel Size = 3000 pcs.
TEMP. CODE: C: -30 to +80°C		

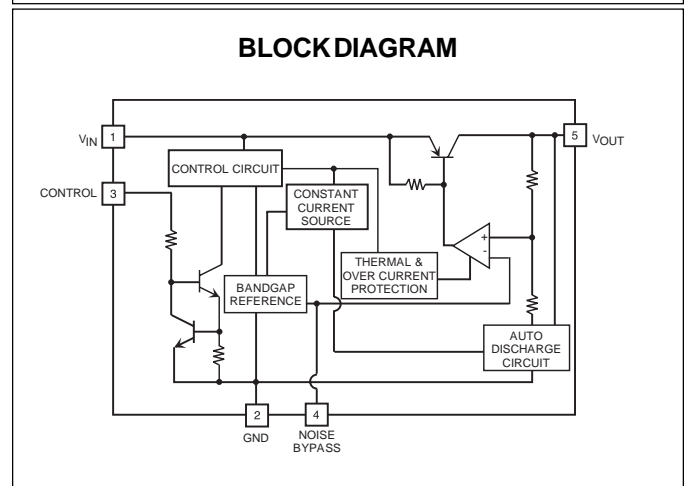
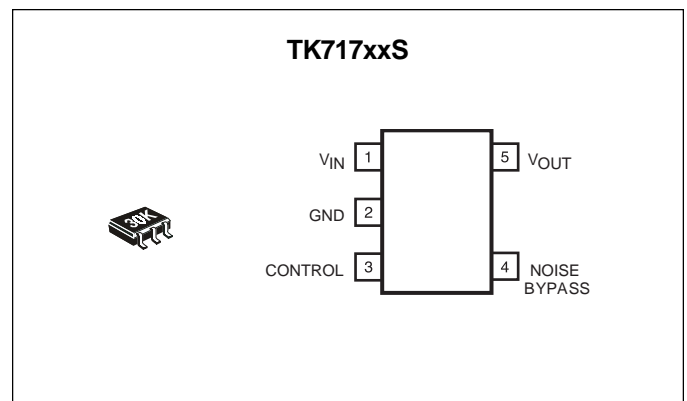

TK717xxS

ABSOLUTE MAXIMUM RATINGS

Supply Voltage	-0.4 to 16 V	Operating Temperature Range	-30 to +80 °C
Power Dissipation (Note 1)	500 mW	Noise Bypass Pin Voltage	-0.4 to 5 V
Reverse Bias Voltage	-0.4 to 6 V	Control Pin Voltage	-0.4 to 16 V
Operating Voltage Range	1.8 to 14 V	Short Circuit Current	410 mA
Storage Temperature Range	-55 to +150 °C		

TK717xxSCL ELECTRICAL CHARACTERISTICS

Test conditions: $T_A = 25\text{ °C}$, $V_{IN} = V_{OUT(TYP)} + 1\text{ V}$, $V_{CONT} \geq 1.8\text{ V}$, unless otherwise specified.

SYMBOL	PARAMETER	TEST CONDITIONS	MIN	TYP	MAX	UNITS
V_{OUT}	Output Voltage		See Table 1			
Line Reg	Line Regulation	$V_{IN} = V_{OUT(TYP)} + 1\text{ V}$ to $V_{OUT(TYP)} + 6\text{ V}$, $\Delta V = 5\text{ V}$		0.3	5	mV
Load Reg	Load Regulation	$5\text{ mA} < I_{OUT} < 100\text{ mA}$, Note 2		8	24	mV
		$5\text{ mA} < I_{OUT} < 200\text{ mA}$, Note 2		27	61	mV
V_{DROP}	Dropout Voltage (Note 5)	$I_{OUT} = 50\text{ mA}$		65	130	mV
		$I_{OUT} = 100\text{ mA}$		103	200	mV
		$I_{OUT} = 200\text{ mA}$ ($V_{OUT} \geq 2.4\text{ V}$)		163	300	mV
		$I_{OUT} = 180\text{ mA}$ ($2.1\text{ V} \leq V_{OUT} < 2.4\text{ V}$)		163	300	mV
$I_{OUT(MAX)}$	Maximum Output Current	$V_{OUT} = V_{OUT(TYP)} \times 0.9$ (Note 2)	280	370		mA
		$1.8\text{ V} \leq V_{IN} \leq 2.1\text{ V}$, Reference Value		250		mA
I_Q	Quiescent Current	$I_{OUT} = 0\text{ mA}$ Excluding I_{CONT}		72	110	μA
I_{STBY}	Standby Current	$V_{CC} = 8\text{ V}$, $V_{CONT} \leq 0.15\text{ V}$, OFF Mode		0.0	0.1	μA
I_{GND}	GND Pin Current	$I_{OUT} = 50\text{ mA}$		0.8	1.5	mA
I_{dis}	Discharge Current	$V_{REV} = 2\text{ V}$, OFF Mode (71720)	13	29		mA
		$V_{REV} = 3\text{ V}$, OFF Mode (71730)	23	38		mA
		$V_{REV} = 4\text{ V}$, OFF Mode (71740)	25	41		mA
		$V_{REV} = 5\text{ V}$, OFF Mode (71750)	27	44		mA
CONTROL TERMINAL SPECIFICATIONS (See Note 3 and 4)						
I_{CONT}	Control Current	$V_{OUT} = 1.8\text{ V}$, ON State		0.86	2.5	μA
V_{CONT}	Control Voltage	ON State	1.6			V
		OFF State			0.6)V

TK717xxSCL ELECTRICAL CHARACTERISTICS (CONT.)

Test conditions: $T_A = 25\text{ }^\circ\text{C}$, $V_{IN} = V_{OUT(TYP)} + 1\text{ V}$, $V_{CONT} \geq 1.8\text{ V}$, unless otherwise specified.

SYMBOL	PARAMETER	TEST CONDITIONS	MIN	TYP	MAX	UNITS
V_{REF}	Noise Bypass Terminal Voltage			1.26		V
$\Delta V_{OUT}/\Delta T_A$	Temperature Coefficient			25		ppm / $^\circ\text{C}$
V_{NO}	Output Noise	$V_{OUT} = 3\text{ V}$, $f = 1\text{ kHz}$, $C_N = 0.1\text{ }\mu\text{F}$		0.20		$\mu\text{V}/\sqrt{\text{Hz}}$
		$V_{OUT} = 3\text{ V}$, at BW 400 Hz to 80 kHz		45		μV_{RMS}
RR	Ripple Rejection	$f = 400\text{ Hz}$, $CL = 1.0\text{ }\mu\text{F}$, $C_N = 0.01\text{ }\mu\text{F}$, $V_{NOISE} = 200\text{ }\mu\text{V}_{RMS}$, $V_{IN} = V_{OUT(TYP)} + 1.5\text{ V}$, $I_{OUT} = 10\text{ mA}$		84		dB
		$f = 1\text{ kHz}$, $CL = 1.0\text{ }\mu\text{F}$, $C_N = 0.01\text{ }\mu\text{F}$, $V_{NOISE} = 200\text{ }\mu\text{V}_{RMS}$, $V_{IN} = V_{OUT(TYP)} + 1.5\text{ V}$, $I_{OUT} = 10\text{ mA}$		80		dB

Note 1: Power dissipation is 150 mW in free air. Power dissipation is 500 mW when mounted as recommended. Derate at 4.0 mW/ $^\circ\text{C}$ for operation above 25 $^\circ\text{C}$.

Note 2: This value depends on the output voltage. This is a reference value for a 3 V output device.

Note 3: The input current decreases to the pA level by connecting the control terminal to GND.

Note 4: The pull-down resistor is not built-in.

Note 5: The minimum operating voltage for V_{IN} can be 1.8 V. Also, the minimum voltage required for V_{IN} is $V_{IN} = V_{DROP} + V_{OUT}$. As a result, operating at $V_{OUT} \leq 2.0\text{ V}$ at the minimum input operating voltage is not preferred.

General Note: Parameters with only typical values are just reference. (Not guaranteed)

General Note: The operation of -30 $^\circ\text{C}$ to 80 $^\circ\text{C}$ is guaranteed by design (verified by sample inspection).

General Note: Exceeding the "Absolute Maximum Rating" may damage the device.

General Note: Connecting a capacitor to the noise by pass pin will decrease the output noise voltage.

TK717xxSCL ELECTRICAL CHARACTERISTICS TABLE 1

Test Conditions: $V_{IN} = V_{OUT(TYP)} + 1\text{ V}$, $I_{OUT} = 5\text{ mA}$, $T_A = 25\text{ °C}$, unless otherwise specified.

Availability	Output Voltage	Voltage Code	Standard Temp. Range Spec. Room Temp ($T_A = 25\text{ °C}$)		Extended Temp. Range Spec. Full Temp ($T_A = -40\text{ to }85\text{ °C}$)	
			$V_{OUT}\text{ Min}$	$V_{OUT}\text{ Max}$	$V_{OUT}\text{ Min}$	$V_{OUT}\text{ Max}$
*	1.5 V	15	1.450 V	1.550 V	1.420 V	1.580 V
	1.6 V	16	1.550 V	1.650 V	1.520 V	1.680 V
	1.7 V	17	1.650 V	1.750 V	1.620 V	1.780 V
*	1.8 V	18	1.750 V	1.850 V	1.720 V	1.880 V
*	1.9 V	19	1.850 V	1.950 V	1.820 V	1.980 V
*	2.0 V	20	1.950 V	2.050 V	1.920 V	2.080 V
	2.1 V	21	2.050 V	2.150 V	2.020 V	2.180 V
*	2.2 V	22	2.150 V	2.250 V	2.120 V	2.280 V
	2.3 V	23	2.250 V	2.350 V	2.220 V	2.380 V
	2.4 V	24	2.350 V	2.450 V	2.320 V	2.480 V
*	2.5 V	25	2.450 V	2.550 V	2.420 V	2.580 V
	2.6 V	26	2.550 V	2.650 V	2.520 V	2.680 V
*	2.7 V	27	2.650 V	2.750 V	2.620 V	2.780 V
*	2.8 V	28	2.750 V	2.850 V	2.720 V	2.880 V
*	2.9 V	29	2.850 V	2.950 V	2.820 V	2.980 V
*	3.0 V	30	2.950 V	3.050 V	2.920 V	3.080 V
*	3.1 V	31	3.050 V	3.150 V	3.020 V	3.180 V
*	3.2 V	32	3.150 V	3.250 V	3.120 V	3.280 V
*	3.3 V	33	3.250 V	3.350 V	3.217 V	3.383 V
	3.4 V	34	3.349 V	3.451 V	3.315 V	3.485 V
*	3.5 V	35	3.447 V	3.553 V	3.412 V	3.588 V

TK717xxSCL ELECTRICAL CHARACTERISTICS TABLE 1 (CONT)

Test Conditions: $V_{IN} = V_{OUT(TYP)} + 1\text{ V}$, $I_{OUT} = 5\text{ mA}$, $T_A = 25\text{ }^\circ\text{C}$, unless otherwise specified.

Availability	Output Voltage	Voltage Code	Standard Temp. Range Spec. Room Temp ($T_A = 25^\circ\text{C}$)		Extended Temp. Range Spec. Full Temp ($T_A = -40\text{ to }85^\circ\text{C}$)	
			$V_{OUT}\text{ Min}$	$V_{OUT}\text{ Max}$	$V_{OUT}\text{ Min}$	$V_{OUT}\text{ Max}$
*	3.6 V	36	3.546 V	3.654 V	3.510 V	3.690 V
	3.7 V	37	3.644 V	3.756 V	3.607 V	3.793 V
*	3.8 V	38	3.743 V	3.857 V	3.705 V	3.895 V
	3.9 V	39	3.841 V	3.959 V	3.802 V	3.998 V
*	4.0 V	40	3.940 V	4.060 V	3.900 V	4.100 V
	4.1 V	41	4.038 V	4.162 V	3.997 V	4.203 V
	4.2 V	42	4.137 V	4.263 V	4.095 V	4.305 V
	4.3 V	43	4.235 V	4.365 V	4.192 V	4.408 V
	4.4 V	44	4.334 V	4.466 V	4.290 V	4.510 V
*	4.5 V	45	4.432 V	4.568 V	4.387 V	4.613 V
	4.6 V	46	4.531 V	4.669 V	4.485 V	4.715 V
*	4.7 V	47	4.629 V	4.771 V	4.582 V	4.818 V
	4.8 V	48	4.728 V	4.872 V	4.680 V	4.920 V
	4.9 V	49	4.826 V	4.974 V	4.777 V	5.023 V
*	5.0 V	50	4.925 V	5.075 V	4.875 V	5.125 V

Note: * Denotes voltage presently available.
Consult factory for availability of other voltages.

TEST CIRCUIT

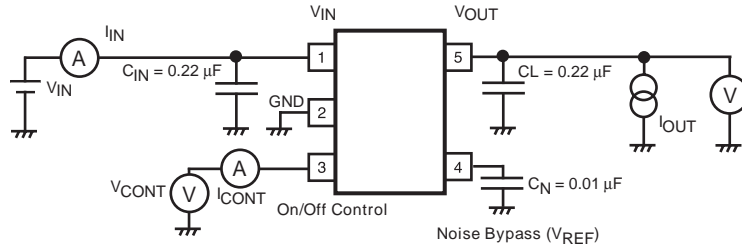

TYPICAL PERFORMANCE CHARACTERISTICS

Noise Performance

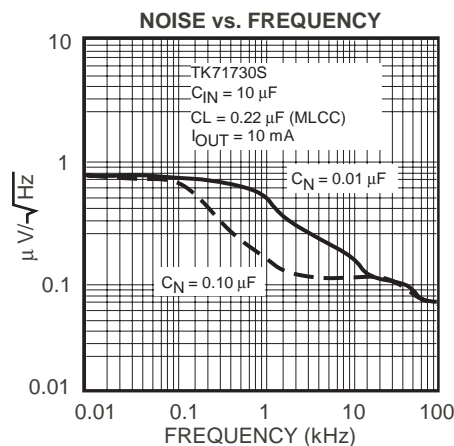
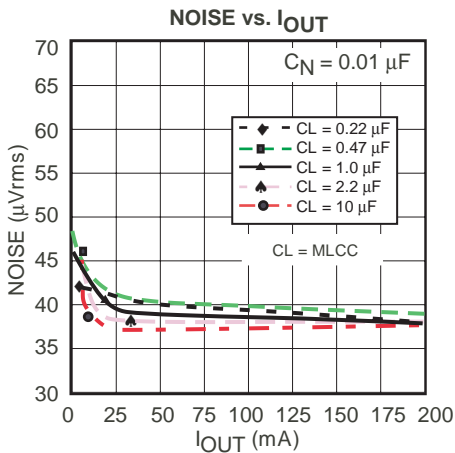
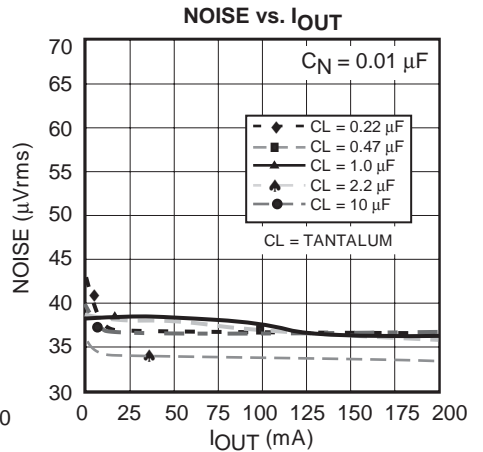
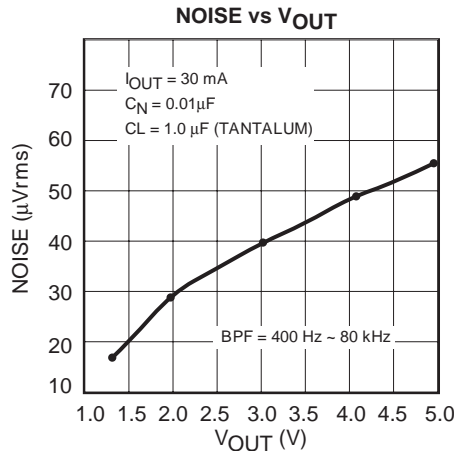
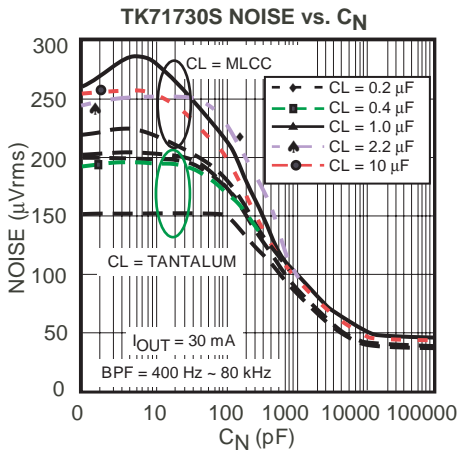

For better noise reduction it is more effective to increase C_N without increasing CL . The recommended C_N capacitance is 6800 pF or 0.01 μF . As the output voltage increases, the noise will also increase.

TYPICAL PERFORMANCE CHARACTERISTICS (CONT.)

Ripple Rejection

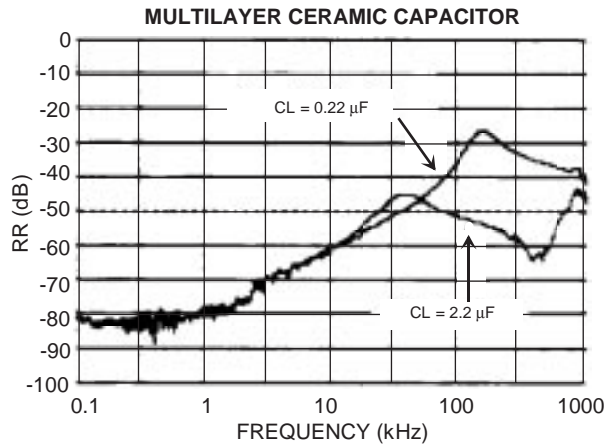

Conditions:
 $V_{IN} = 5.0\text{ V}$
 $V_{OUT} = 3.0\text{ V}$
 $I_{OUT} = 10\text{ mA}$
 $V_{RIPPLE} = 500\text{ mVp-p}$
 $f = 100\text{ Hz to }1\text{ MHz}$
 $C_{IN} = 0\text{ pF}$
 $C_N = 0.01\text{ }\mu\text{F}$

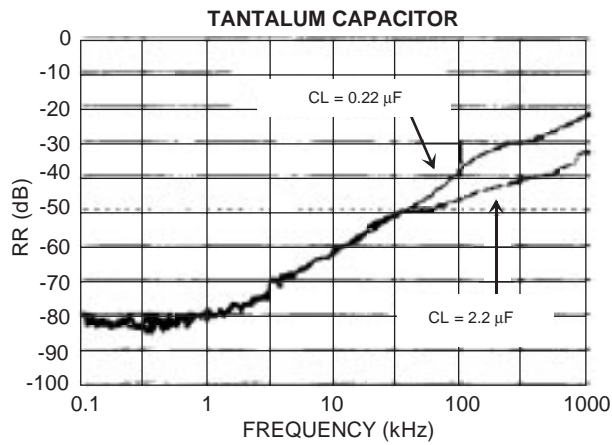
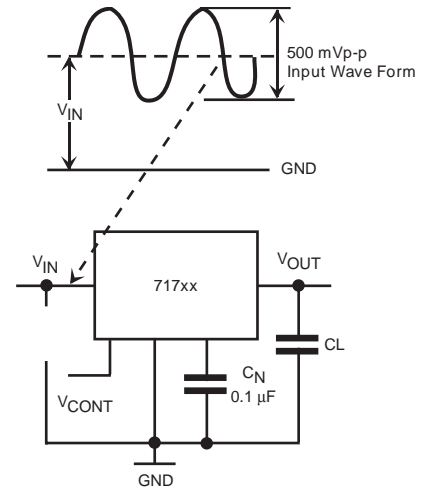

The ripple rejection characteristic depends on the characteristic and the capacitance value of the capacitor connected to the output side. The RR characteristic of 50 kHz or more varies greatly with the capacitor on the output side and the PCB. Please confirm your expectations with your actual design, if necessary.

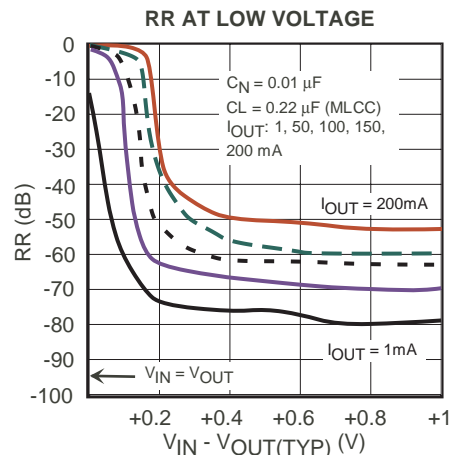
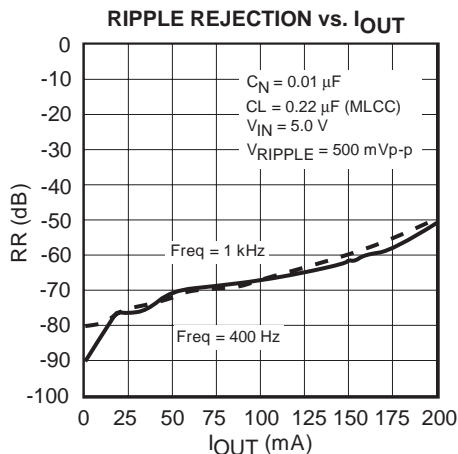

TYPICAL PERFORMANCE CHARACTERISTICS (CONT.)

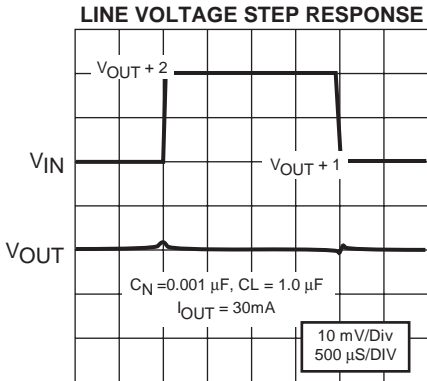
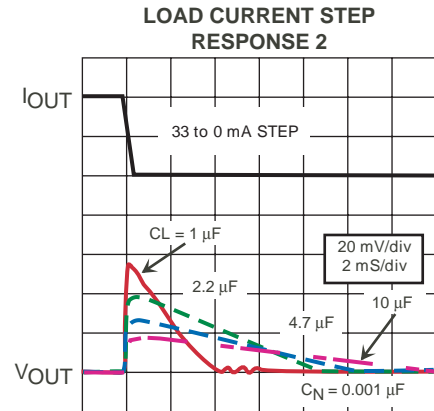
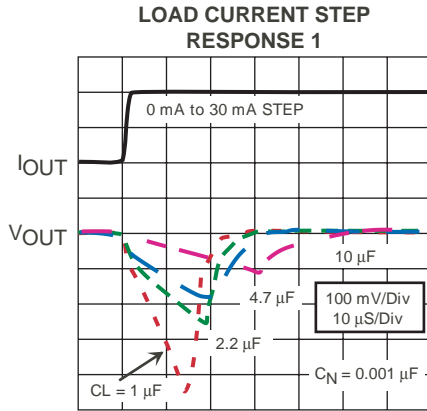

ON/OFF Speed

The ON/OFF switching speed greatly depends on the values of the output and the noise bypass capacitors. The ON/OFF switching speed improves when these capacitances are reduced. However, the Load transient and Line transient responses deteriorate when C_N and C_L capacitances are small. In addition, the output noise increases. Toko recommends setting $C_L = 0.22 \mu F$ and $C_N = 1000 pF$ when fast switching speeds are needed. Please increase each capacitance when low noise is desired. Refer to the figures below.

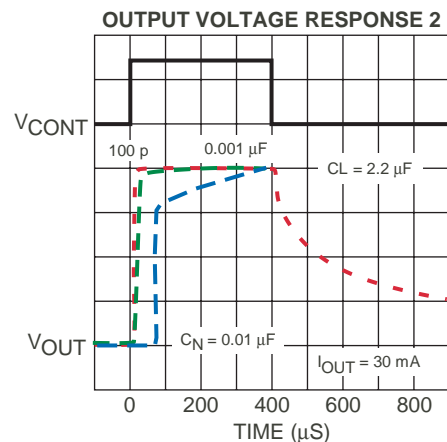
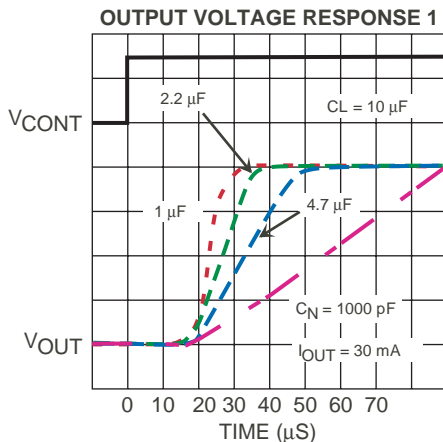

TYPICAL PERFORMANCE CHARACTERISTICS (CONT.)

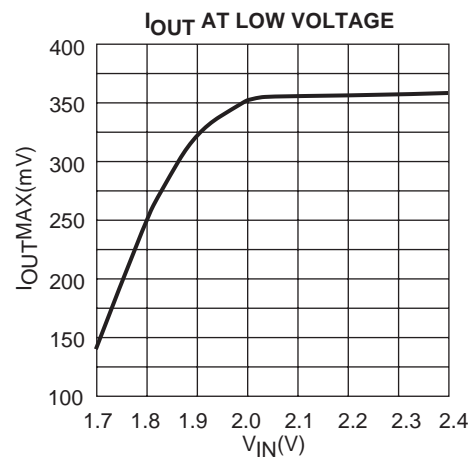
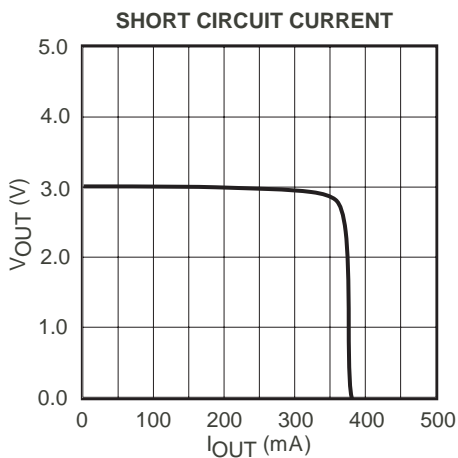
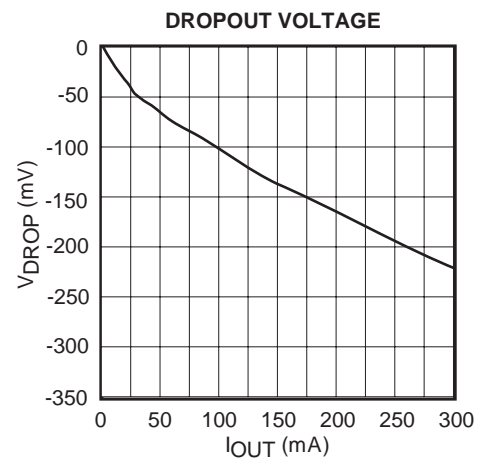
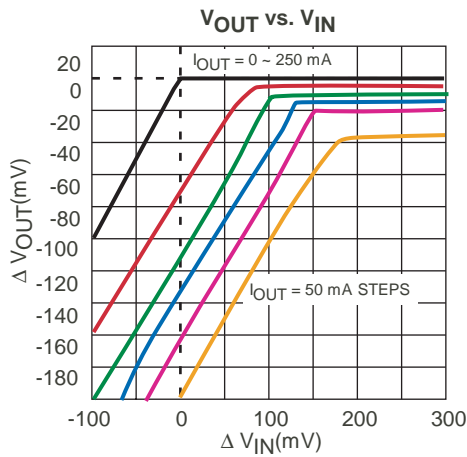
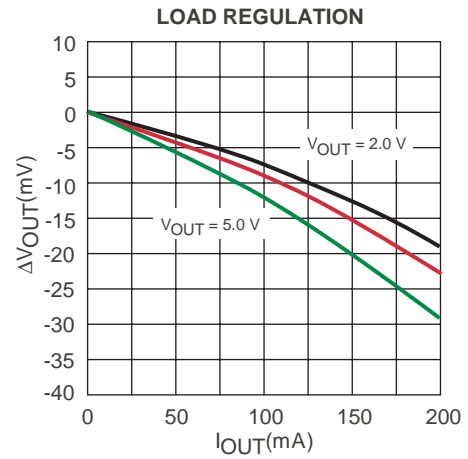
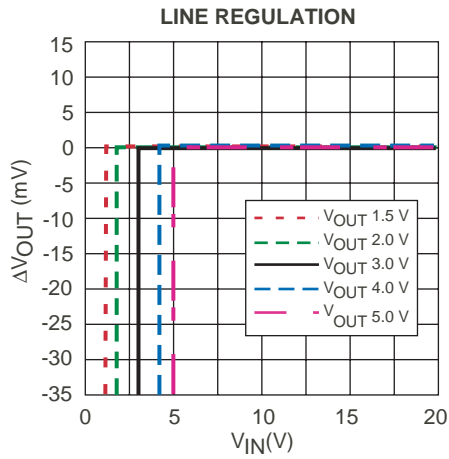

TYPICAL PERFORMANCE CHARACTERISTICS (CONT.)

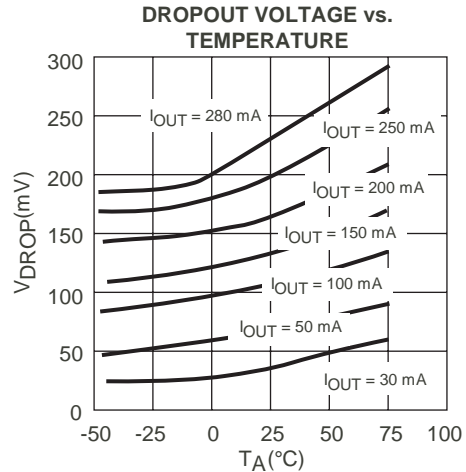
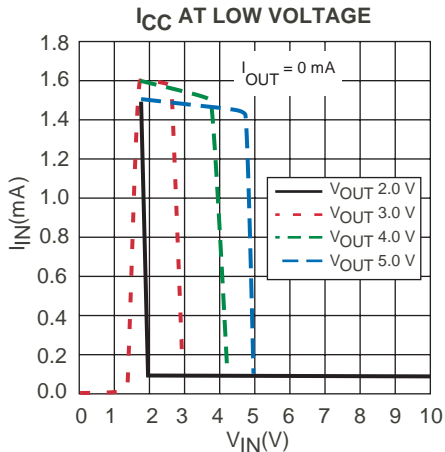
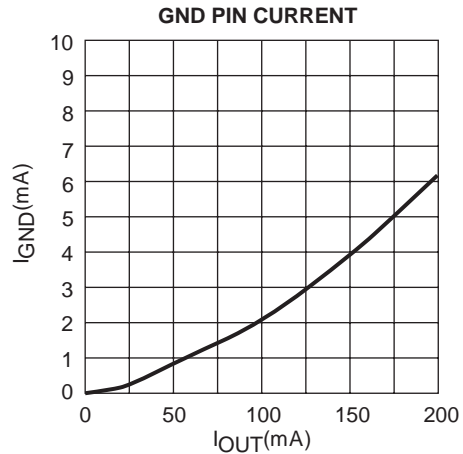
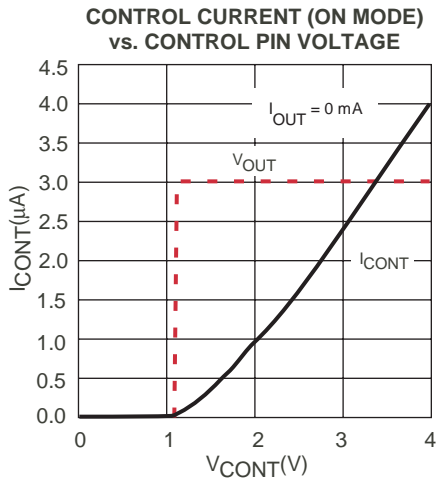
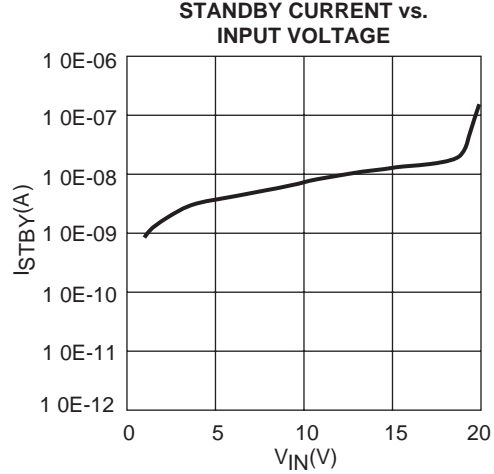
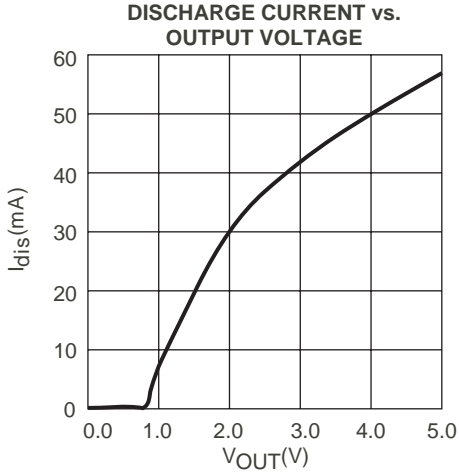

TYPICAL PERFORMANCE CHARACTERISTICS (CONT.)

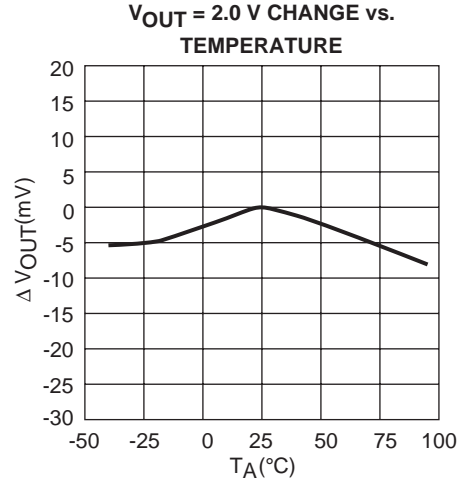
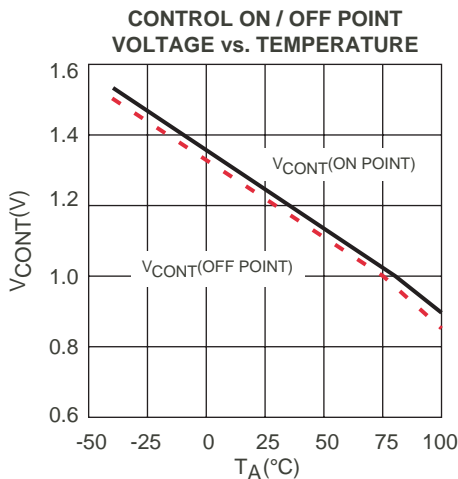
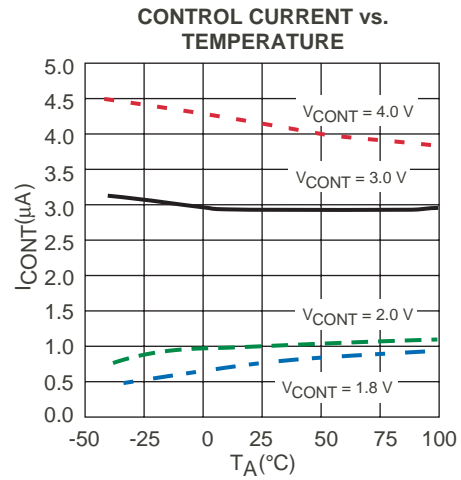
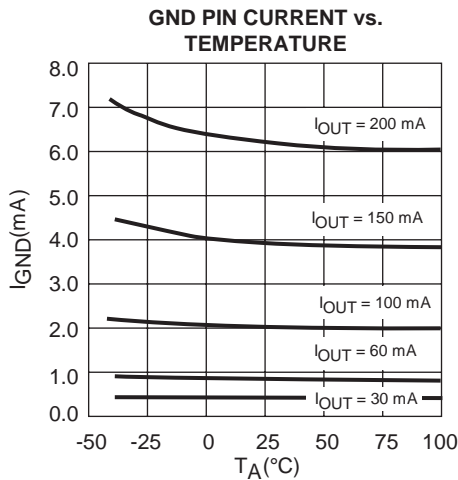
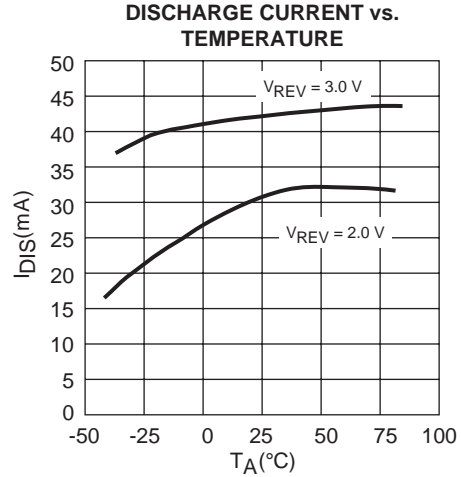
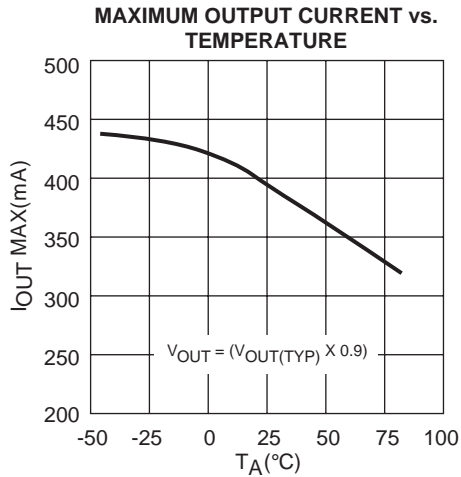

TYPICAL PERFORMANCE CHARACTERISTICS (CONT.)

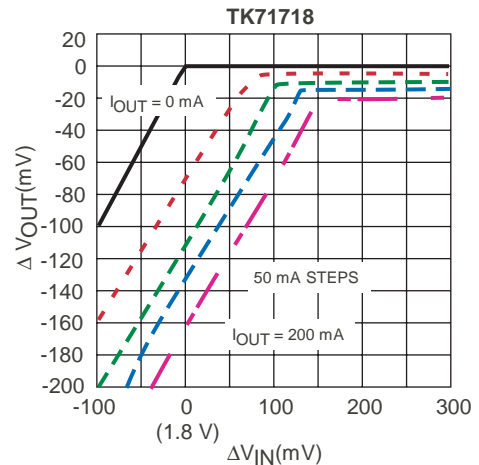
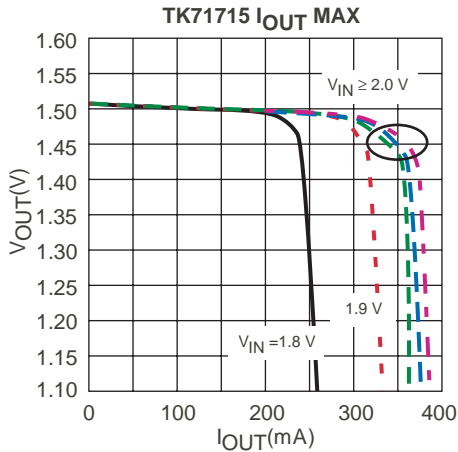
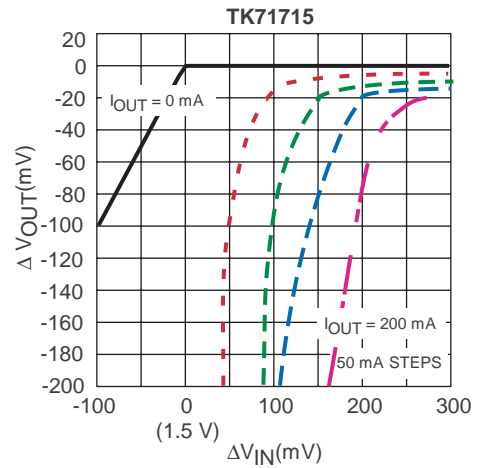
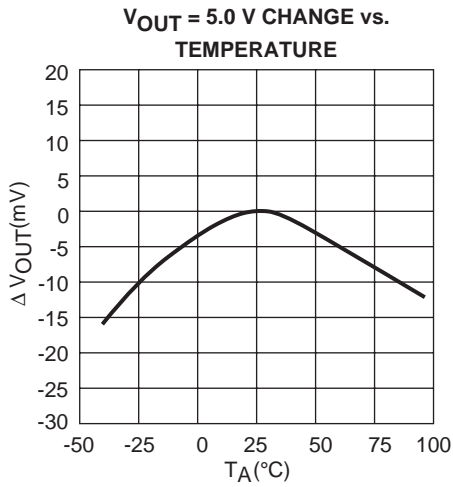
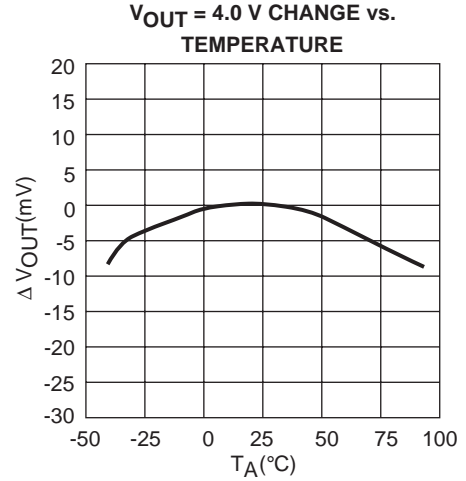
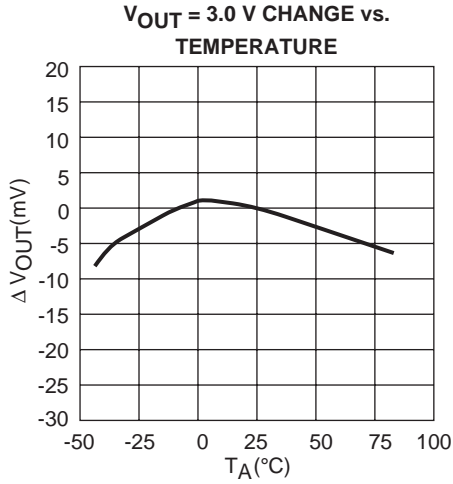

TYPICAL PERFORMANCE CHARACTERISTICS (CONT.)

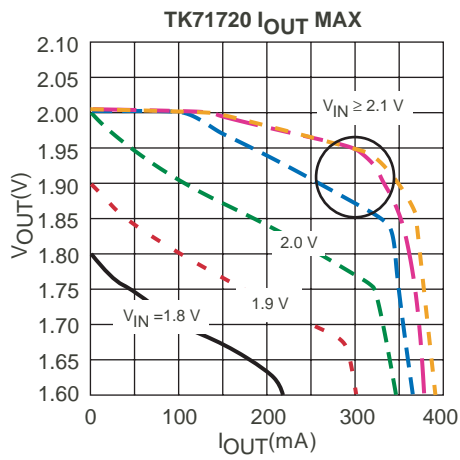
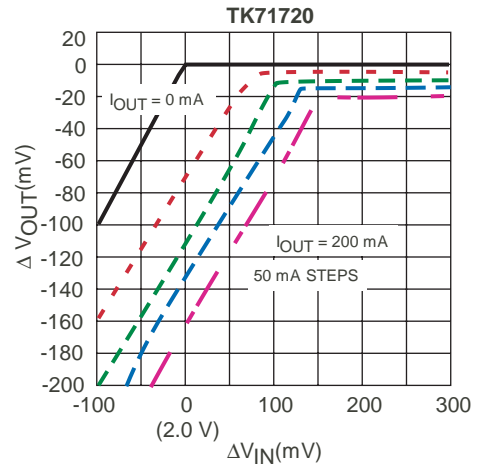
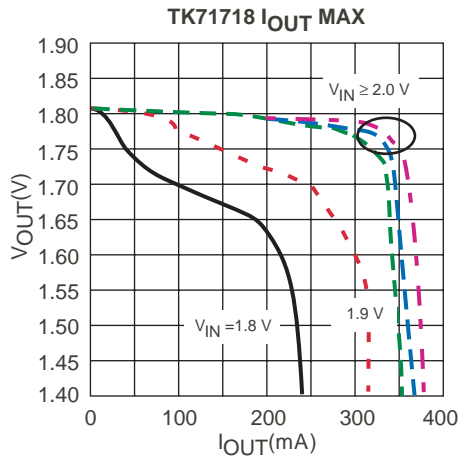

DEFINITION AND EXPLANATION OF TECHNICAL TERMS

OUTPUT VOLTAGE (V_{OUT})

The output voltage is specified with $V_{IN} = (V_{OUT(TYP)} + 1 \text{ V})$ and $I_{OUT} = 5 \text{ mA}$.

MAXIMUM OUTPUT CURRENT ($I_{OUT(MAX)}$)

The rated output current is specified under the condition where the output voltage drops 0.9 times the value specified with $I_{OUT} = 5 \text{ mA}$. This input voltage is set to $V_{OUT(TYP)} + 1 \text{ V}$, and the current is pulsed to minimize temperature effect. The output current decreases during low voltage operation.

DROPOUT VOLTAGE (V_{DROP})

The dropout voltage is the difference between the input voltage and the output voltage at which point the regulator starts to fall out of regulation (this is the point when the output voltage decreases by 100 mV). Below this value, the output voltage will fall as the input voltage is reduced. It is dependent upon the load current and the junction temperature.

LINE REGULATION (Line Reg)

Line regulation is the ability of the regulator to maintain a constant output voltage as the input voltage changes. The line regulation is specified as the input voltage is changed from $V_{IN} = V_{OUT} + 1 \text{ V}$ to $V_{IN} = V_{OUT} + 6 \text{ V}$. It is a pulsed measurement to minimize temperature effects.

LOAD REGULATION (Load Reg)

Load regulation is the ability of the regulator to maintain a constant output voltage as the load current changes. It is a pulsed measurement to minimize temperature effects with the input voltage set to $V_{IN} = V_{OUT} + 1 \text{ V}$. The load regulation is specified under two output current step conditions of 5 mA to 100 mA and 5 mA to 200 mA.

QUIESCENT CURRENT (I_Q)

The quiescent current is the current which flows through the ground terminal under no load conditions ($I_{OUT} = 0 \text{ mA}$).

GROUND PIN CURRENT (I_{GND})

The ground pin current is the current which flows through the GND terminal according to load current. It is measured by (input current-output current).

RIPPLE REJECTION RATIO (RR)

Ripple rejection is the ability of the regulator to attenuate the ripple content of the input voltage at the output. It is specified with 500 mV_{RMS}, 100 Hz and 1 MHz signal

superimposed on the input voltage, where $V_{IN} = V_{OUT} + 1.5 \text{ V}$. The output decoupling capacitor is set to 1.0 μF , the noise bypass capacitor is set to 0.01 μF , and the load current is set to 10 mA. Ripple rejection is the ratio of the ripple content of the output vs. the input and is expressed in dB. Ripple rejection can be improved by increasing the noise bypass capacitor (However, the on/off response time will increase).

STANDBY CURRENT (I_{STBY})

Standby current is the current into the regulator when the output is turned off by the control function. It is measured with an input voltage of 8 V.

OVER CURRENT SENSOR

The overcurrent sensor protects the device when there is excessive output current. It also protects the device if the output is accidentally shorted to ground.

THERMAL SENSOR

The thermal sensor protects the device if the junction temperature exceeds the safe value ($T_j = 150 \text{ }^\circ\text{C}$). This temperature rise can be caused by extreme heat, excessive power dissipation caused by large output voltage drops, or excessive output current. The regulator will shut off when the temperature exceeds the safe value. As the junction temperature decreases, the regulator will begin to operate again. Under sustained fault conditions, the regulator output will oscillate as the device turns off then resets. Damage may occur to the device under extreme fault conditions.

REVERSE VOLTAGE PROTECTION

Reverse voltage protection prevents damage due to the output voltage being higher than the input voltage. This fault condition can occur when the output capacitor remains charged and the input is reduced to zero, or when an external voltage higher than the input voltage is applied to the output side. Toko's regulators do not need an inherent diode connected between the input and output. The maximum reverse bias voltage is 6 V.

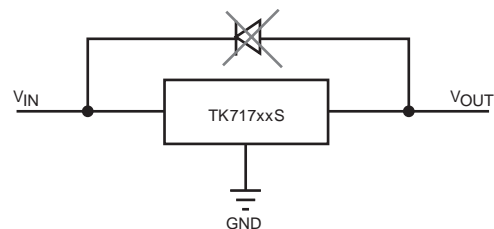

DEFINITION AND EXPLANATION OF TECHNICAL TERMS (CONT.)

PACKAGE POWER DISSIPATION (P_D)

This is the power dissipation level at which the thermal sensor is activated. The IC contains an internal thermal sensor which monitors the junction temperature. When the junction temperature exceeds the monitor threshold of 150 °C, the IC is shut down. The junction temperature rises as the difference between the input power ($V_{IN} \times I_{IN}$) and the output power ($V_{OUT} \times I_{OUT}$) increases. The rate of temperature rise is greatly affected by the mounting pad configuration on the PCB, the board material, and the ambient temperature. When the IC mounting has good thermal conductivity, the junction temperature will be low even if the power dissipation is large. When mounted on the recommended mounting pad, the power dissipation of the SOT23-5 is increased to 500 mW. For operation at ambient temperatures over 25 °C, the power dissipation of the SOT23-5 device should be derated at 4.0 mW/°C. To determine the power dissipation for shutdown when mounted, attach the device on the actual PCB and deliberately increase the output current (or raise the input voltage) until the thermal protection circuit is activated. Calculate the power dissipation of the device by subtracting the output power from the input power. These measurements should allow for the ambient temperature of the PCB. The value obtained from $P_D / (150 \text{ °C} - T_A)$ is the derating factor. The PCB mounting pad should provide maximum thermal conductivity in order to maintain low device temperatures. As a general rule, the lower the temperature, the better the reliability of the device. The thermal resistance when mounted is expressed as follows:

$$T_j = \theta_{jA} \times P_D + T_A$$

For Toko ICs, the internal limit for junction temperature is 150 °C. If the ambient temperature (T_A) is 25 °C, then:

$$\begin{aligned} 150 \text{ °C} &= \theta_{jA} \times P_D + 25 \text{ °C} \\ \theta_{jA} &= 125 \text{ °C} / P_D \\ \theta_{jA} &= 125 \text{ °C} / P_D \text{ (°C / mW)} \end{aligned}$$

P_D is the value when the thermal protection circuit is activated. A simple way to determine P_D is to calculate $V_{IN} \times I_{IN}$ when the output side is shorted. Input current gradually falls as temperature rises. You should use the value when thermal equilibrium is reached.

The range of usable currents can also be found from the graph below.

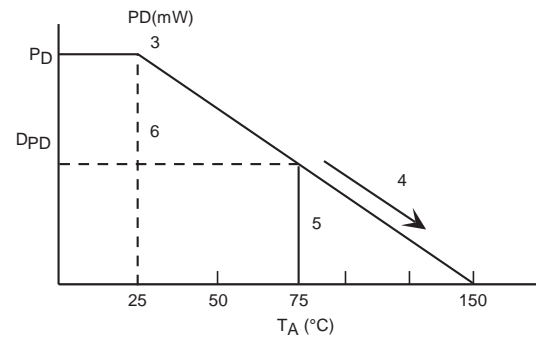

Procedure:

- 1) Find P_D
- 2) P_{D1} is taken to be $P_D \times (\sim 0.8 - 0.9)$
- 3) Plot P_{D1} against 25 °C
- 4) Connect P_{D1} to the point corresponding to the 150 °C with a straight line.
- 5) In design, take a vertical line from the maximum operating temperature (e.g., 75 °C) to the derating curve.
- 6) Read off the value of P_D against the point at which the vertical line intersects the derating curve. This is taken as the maximum power dissipation, D_{PD} .

The maximum operating current is:

$$I_{OUT} = (D_{PD} / (V_{IN(MAX)} - V_{OUT}))$$

APPLICATION INFORMATION (CONT.)

BOARDLAYOUT

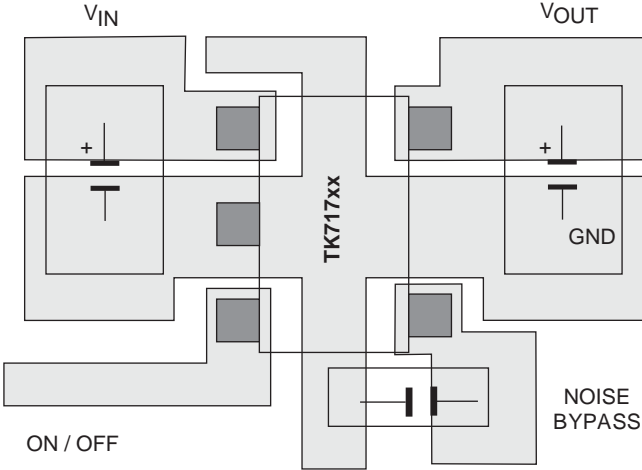

SOT23-5 BOARDLAYOUT

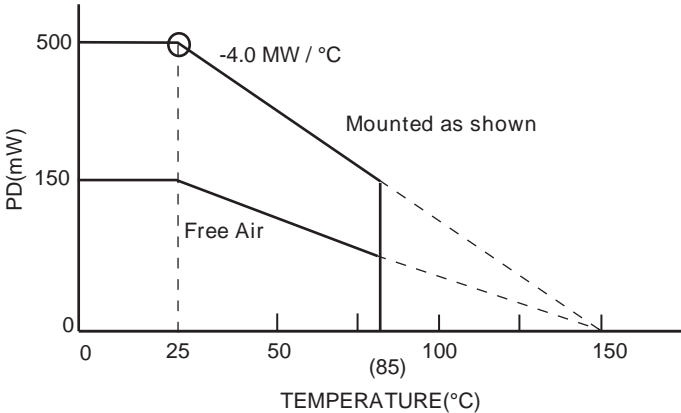

APPLICATION INFORMATION (CONT.)

INPUT-OUTPUT CAPACITORS

Linear regulators require input and output capacitors in order to maintain the regulator's loop stability. The equivalent series resistance (ESR) of the output capacitor must be in the stable operation area. However, it is recommended to use as large a value of capacitance as is practical. The output noise and the ripple noise decrease as the capacitance value increases. The IC is never damaged by enlarging the capacitance.

ESR values vary widely between ceramic and tantalum capacitors. However, tantalum capacitors are assumed to provide more ESR damping resistance, which provides greater circuit stability. This implies that a higher level of circuit stability can be obtained by using tantalum capacitors when compared to ceramic capacitors with similar values. The IC provides stable operation with an output side capacitor of $0.22\mu\text{F}$ ($V_{\text{OUT}} \geq 2.0\text{ V}$). If the capacitor is $0.1\mu\text{F}$ or more over its full range of temperature, either a ceramic capacitor or tantalum capacitor can be used without considering ESR ($V_{\text{OUT}} \geq 2.0\text{ V}$).

For output voltage device $\geq 2.0\text{ V}$ applications, the recommended value of $C_L \geq 0.22\mu\text{F}$.

For output voltage device $\geq 1.5\text{ V}$ applications, the recommended value of $C_L \geq 0.47\mu\text{F}$.

For load current $\leq 0.5\text{ mA}$, increase the output capacitor to $1\mu\text{F}$.

The input capacitor is necessary when the battery is discharged, the power supply impedance increases, or the line distance to the power supply is long. This capacitor might be necessary on each individual IC even if two or more regulator ICs are used. It is not possible to determine this indiscriminately. Please confirm the stability while mounted.

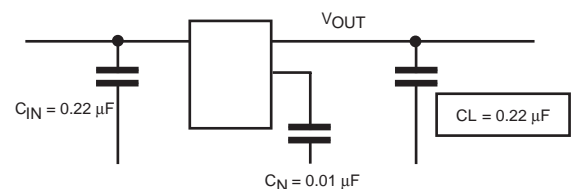

STABLE OPERATION AREA vs. VOLTAGE, CURRENT AND ESR

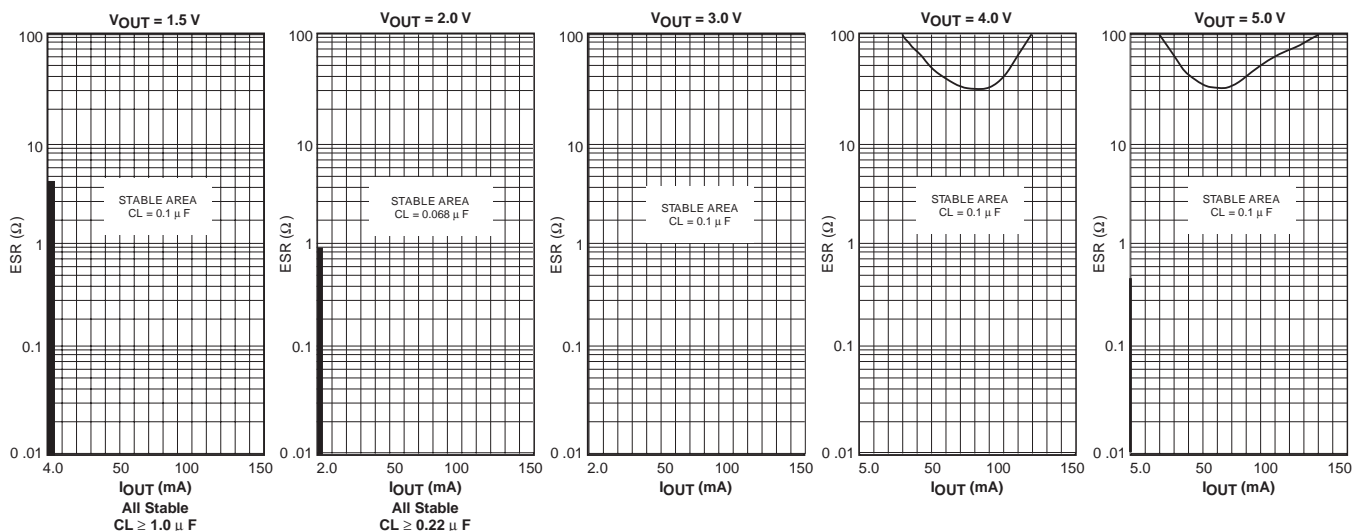

Please increase the output capacitor value when the load current is 0.5 mA or less. The stability of the regulator improves if a big output side capacitor is used (the stable operation area extends).

For evaluation KYOCERA CM05B104K10AB, CM05B224K10AB, CM105B104K16A, CM105B224K16A, CM21B225K10A
MURATA GRM36B104K10, GRM42B104K10, GRM39B104K25, GRM39B224K10, GRM39B105K6.3

APPLICATION INFORMATION (CONT.)

Bias Voltage and Temperature Characteristics of Ceramic Capacitors

Generally, a ceramic capacitor has both a temperature characteristic and a voltage characteristic. Please consider both characteristics when selecting the part. The B curves are the recommended characteristics.

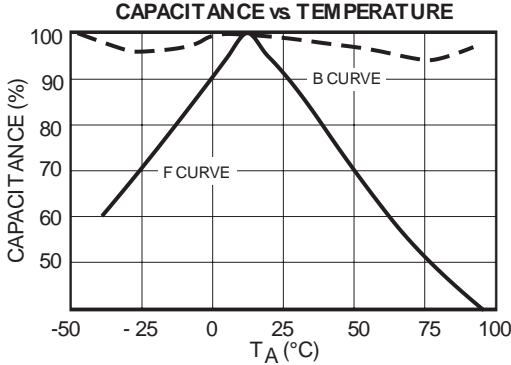
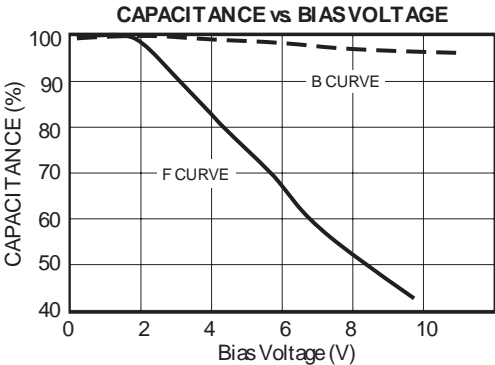

APPLICATION INFORMATION (CONT.)

As shown in the figure below, several components are required to discharge the charge in the output side capacitor in a typical regulator.

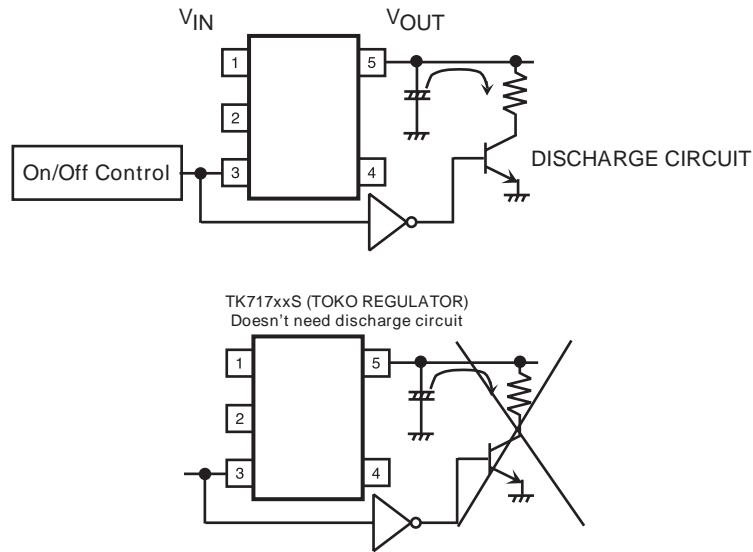

Because the external electrical discharge circuit is unnecessary with the TK717xxS, the application becomes very simple. Turning the regulator off automatically discharges the charge of the output side capacitor.

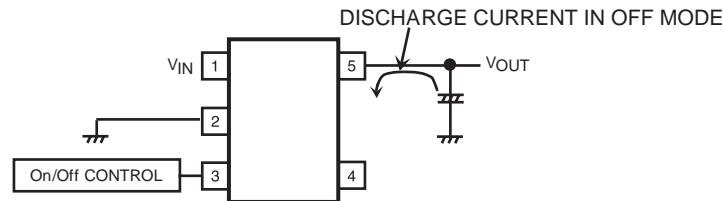

As shown below:

The TK112xxC is a normal regulator.

The TK717xx is built with the automatic discharge circuit during off time.

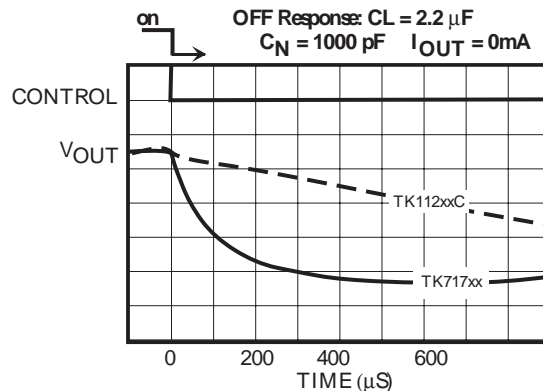

PACKAGE OUTLINE

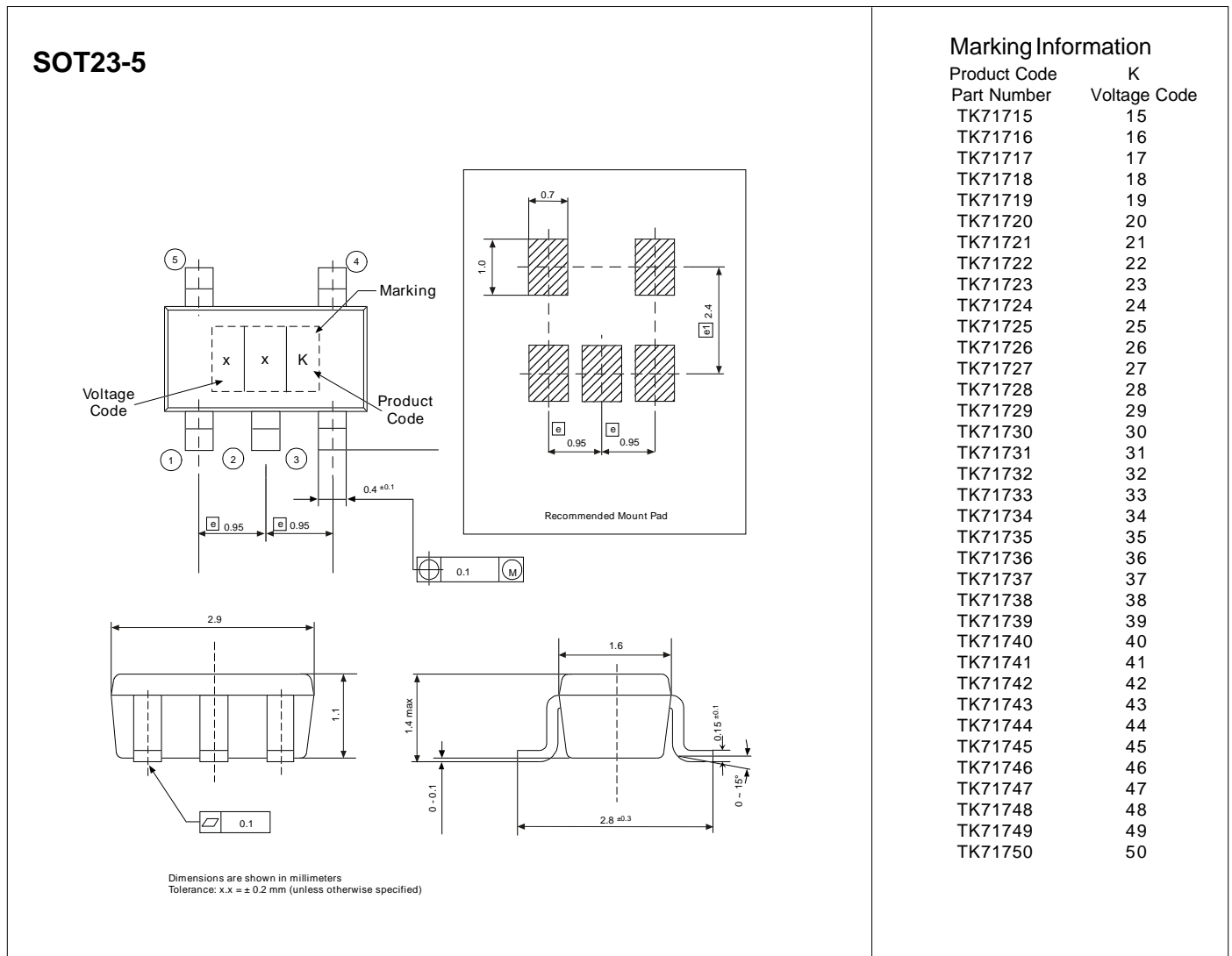

Toko America, Inc. Headquarters
 1250 Feehanville Drive, Mount Prospect, Illinois 60056
 Tel: (847) 297-0070 Fax: (847) 699-7864

TOKO AMERICA REGIONAL OFFICES

Midwest Regional Office
 Toko America, Inc.
 1250 Feehanville Drive
 Mount Prospect, IL 60056
 Tel: (847) 297-0070
 Fax: (847) 699-7864

Semiconductor Technical Support
 Toko Design Center
 4755 Forge Road
 Colorado Springs, CO 80907
 Tel: (719) 528-2200
 Fax: (719) 528-2375

Visit our Internet site at <http://www.tokoam.com>

The information furnished by TOKO, Inc. is believed to be accurate and reliable. However, TOKO reserves the right to make changes or improvements in the design, specification or manufacture of its products without further notice. TOKO does not assume any liability arising from the application or use of any product or circuit described herein, nor for any infringements of patents or other rights of third parties which may result from the use of its products. No license is granted by implication or otherwise under any patent or patent rights of TOKO, Inc. TOKO's products are not authorized for use as critical components in life support devices or systems without the express written approval of the president of Toko, Incorporated.