

TND027MP

Excellent Power Device Lowside Power Switch Lamp / Solenoid / Motor Driving, Single MP



ON Semiconductor®

www.onsemi.com

Features

- N-Channel MOSFET Built in
- Overheat Protection (Self Recovery Type)
- Overcurrent Protection (Self Recovery Type Current Limiting Function)
- Overvoltage Protection

SPECIFICATIONS

ABSOLUTE MAXIMUM RATING at Ta = 25°C (Note 1)

Parameter	Symbol	Value	Unit
Drain to Source Voltage	V _{DS}	60	V
Output Current (DC)	I _O	1.5	A
Input Voltage	V _{IN}	-0.3 to +10	V
Power Dissipation	P _D	1.0	W
Operating Supply Voltage	V _{DS(opr)}	40	V
Operating Temperature	T _{opr}	-40 to +85	°C
Junction Temperature	T _j	150	°C
Storage Temperature	T _{stg}	-55 to +150	°C

Note 1 : Stresses exceeding those listed in the Maximum Ratings table may damage the device. If any of these limits are exceeded, device functionality should not be assumed, damage may occur and reliability may be affected.

MARKING

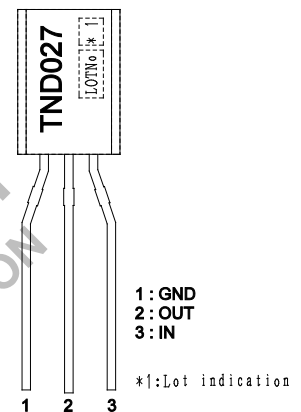

ORDERING INFORMATION

See detailed ordering and shipping information on page 5 of this data sheet.

BLOCK DIAGRAM

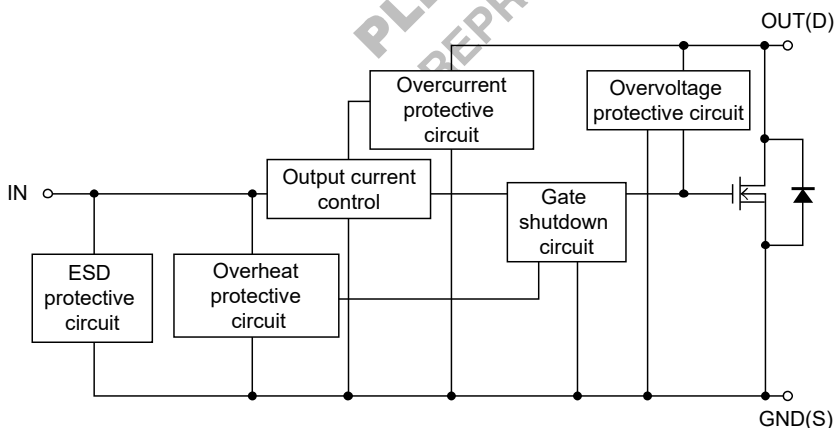

TND027MP

ELECTRICAL CHARACTERISTICS at Ta = 25°C (Note 2, 3, 4)

Parameter	Symbol	Conditions	Value			Unit
			min	typ	max	
Drain to Source Clamp Voltage	$V_{DS, \text{clamp}}$	$V_{IN}=0V, I_O=1mA$	60			V
Output-OFF Current	$I_{DSS(1)}$	$V_{IN}=0V, V_{DS}=50V$			10	μA
	$I_{DSS(2)}$	$V_{IN}=0V, V_{DS}=12V$			5	μA
Input Threshold Voltage	$V_{IN(th)}$	$V_{DS}=5V, I_O=1mA$	1.0	1.5	2.0	V
Protection Circuit Operating Input Voltage	$V_{IN(opr)}$		4		10	V
Drain to Source ON Resistance	$R_{DS(on)}$	$V_{IN}=5V, I_O=1A$		0.3	0.4	Ω
Input Current (Output On)	I_{IN}	$V_{IN}=5V$			0.6	mA
Over-Heat Detecting Temperature	$T_j(sd)$	$V_{IN}=5V, I_O=1A$	120	150	190	$^{\circ}C$
Over-Curret Detecting Current	I_s	$V_{IN}=5V$	3.0	6.0	9.0	A
Over-Curret Limit (Peak)	I_{LMT}	$V_{IN}=5V$	3.0	6.0	9.0	A
Input Clamp Voltage	$V_{IN, \text{clamp}}$	$I_{IN}=1mA$	10			V

Note 2 :Overcurrent protection circuit limits the output current to the range of overcurrent limit value.

Note 3 :During overheating operation, output current is turned off.

Note 4 : Product parametric performance is indicated in the Electrical Characteristics for the listed test conditions, unless otherwise noted. Product performance may not be indicated by the Electrical Characteristics if operated under different conditions.

Sample Application Circuit

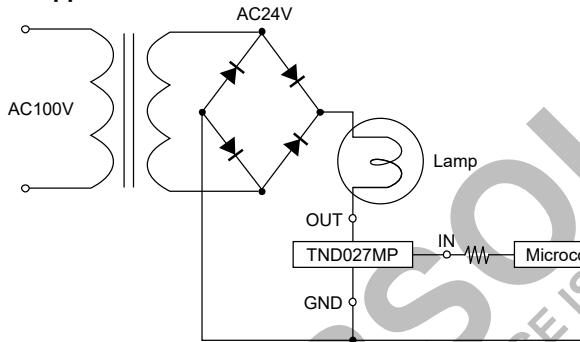

Another Sample Application Circuit (Solenoid drive)

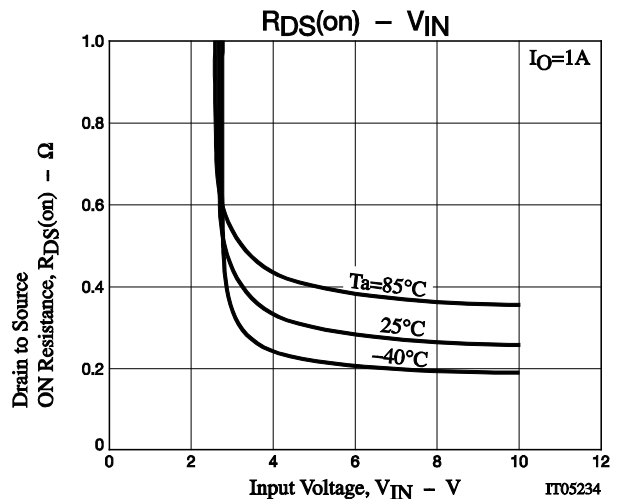
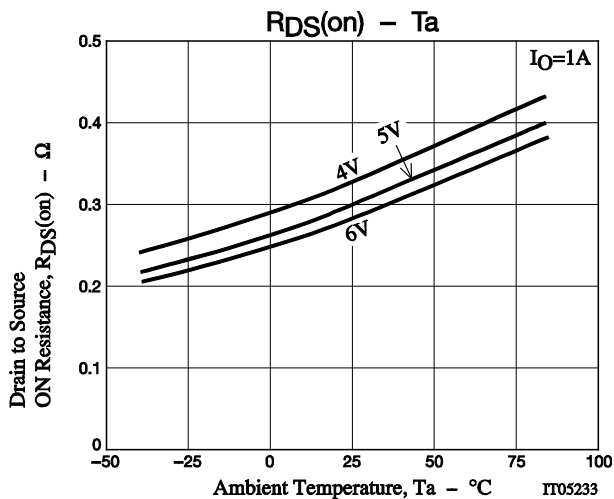
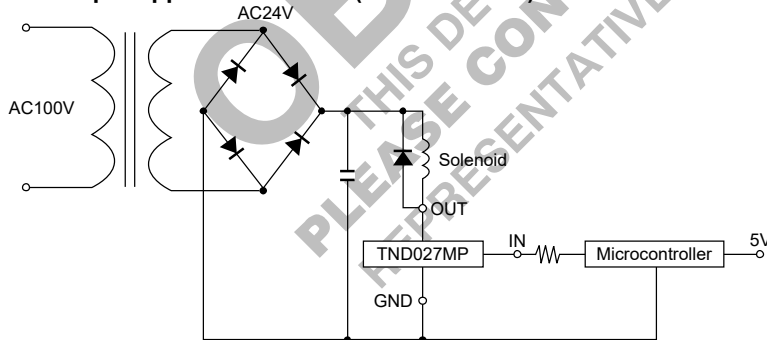

TND027MP

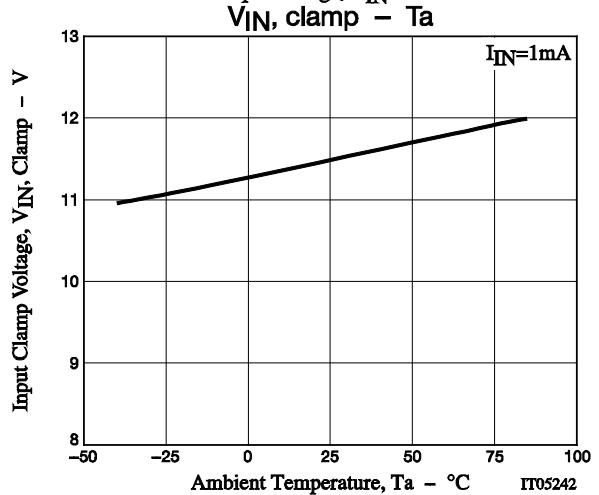
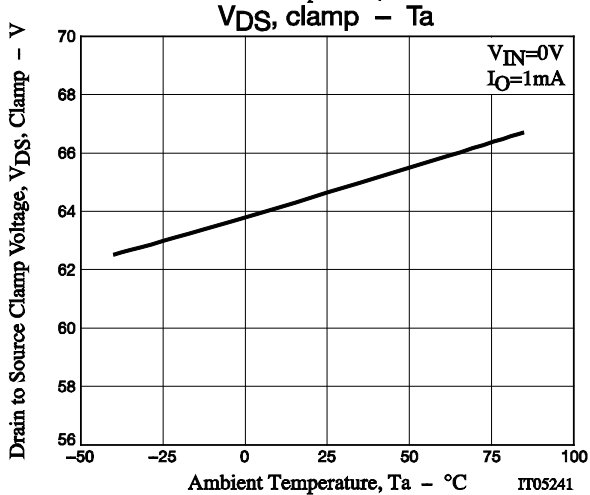
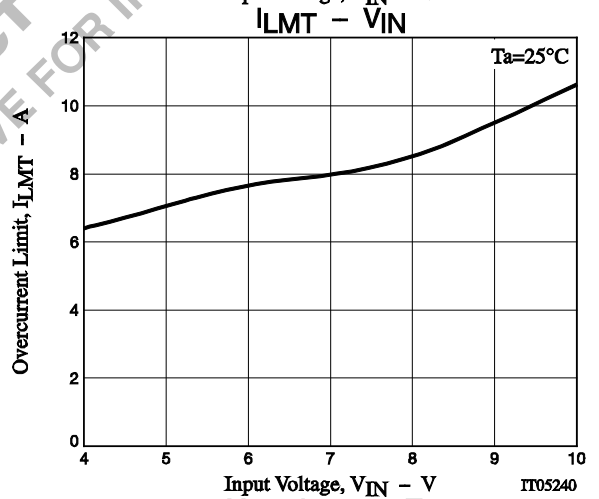
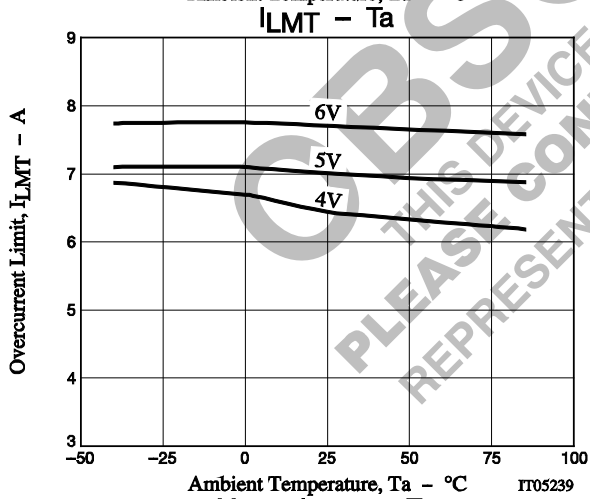
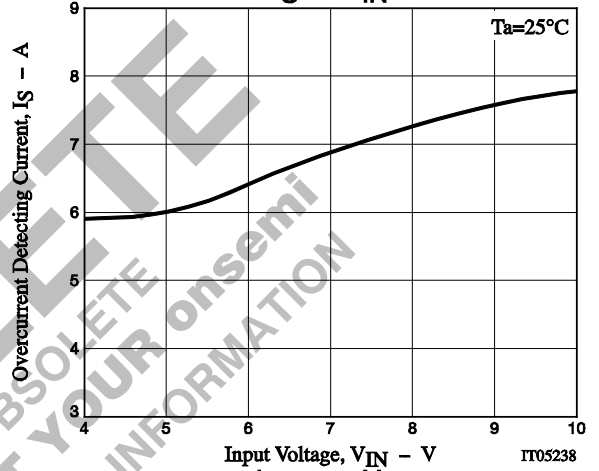
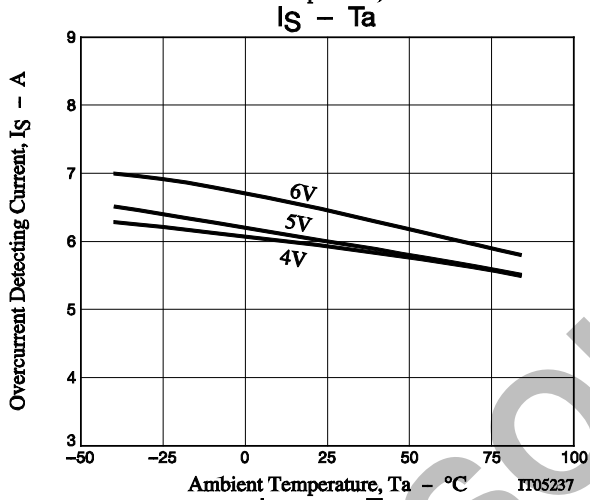
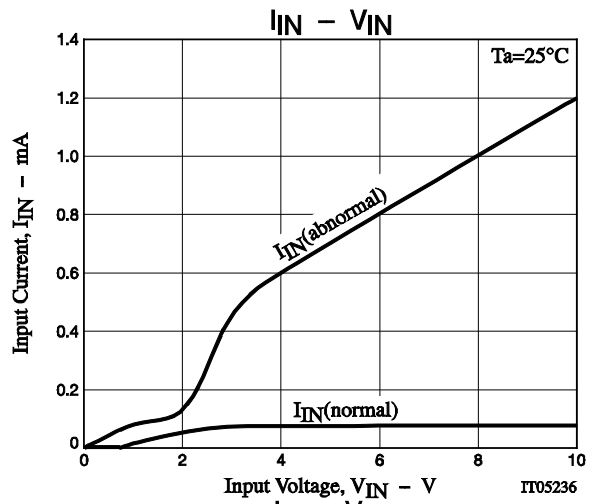
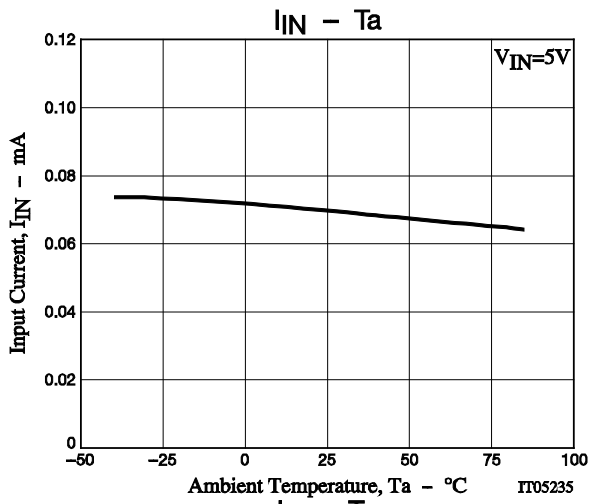

TND027MP

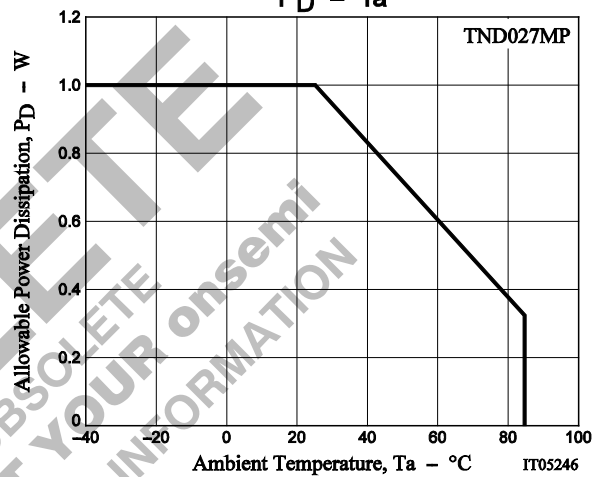
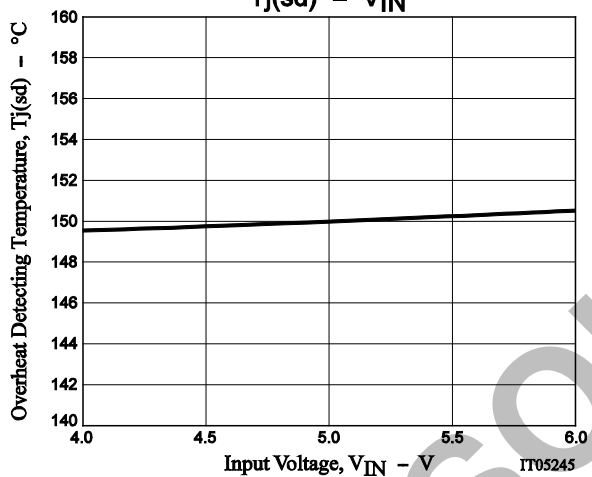
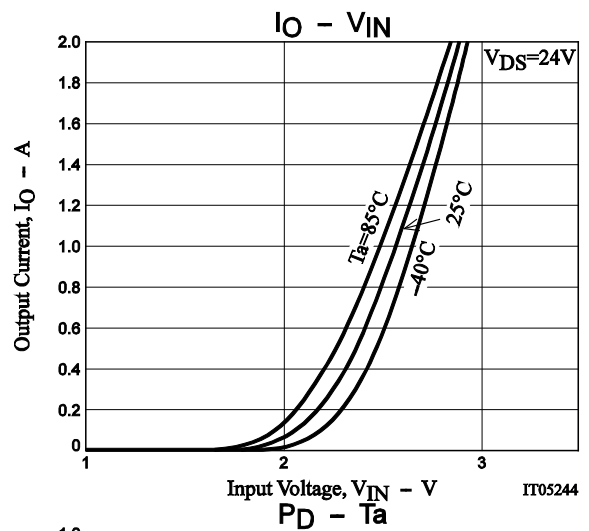
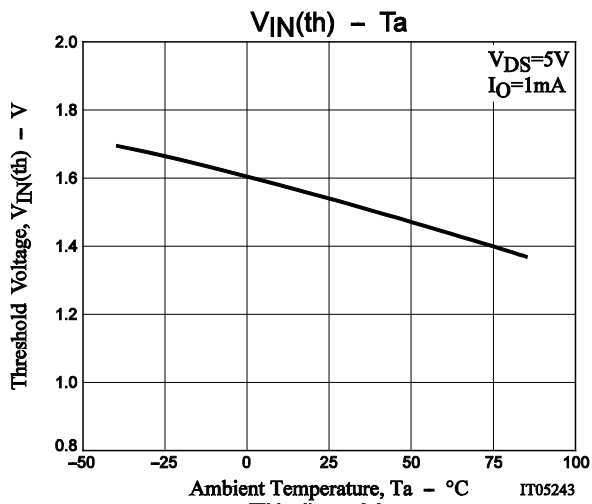

OPERATION DESCRIPTION

- The output power MOSFET will be turned on when the input voltage exceeds the input threshold voltage(4 to 6V is recommended), and then the lamp will be turned on by the current flowing to the lamp. Conversely, the output power MOSFET will be turned off when the input voltage goes below the input threshold voltage, and the lamp will be turned off.
- The inrush current that occurs during normal lamp operation is limited to a preset value by the built-in overcurrent protecting circuit, which makes the lamp life longer.
- The internal overcurrent protection function limits the current of output power MOSFET when output current of at least the overcurrent detecting current value flows at load short. Besides, if the device temperature exceeds the allowable power dissipation, overheat protection function protects the power switch from being broken down by turning off the current of output power MOSFET when T_J comes to 150°C(typical).
- As an example of application circuit, DC voltage can also be controlled as a solenoid drive.

ADDITION

- The diode between OUT and GND in the block diagram is parasitic diode of the MOSFET.
- Not apply a voltage on IN terminal during the period when OUT voltage is lower than GND voltage when driving a solenoid or a motor.
- Be sure connect a diode between OUT terminal and GND terminal when you want to apply a voltage on IN terminal under the above-stated state (that is, OUT Voltage < GND Voltage).

TND027MP

PACKAGE DIMENSIONS

unit : mm

TO-92 3 8.5x6.0 / MP-WA
CASE 135AG
ISSUE O

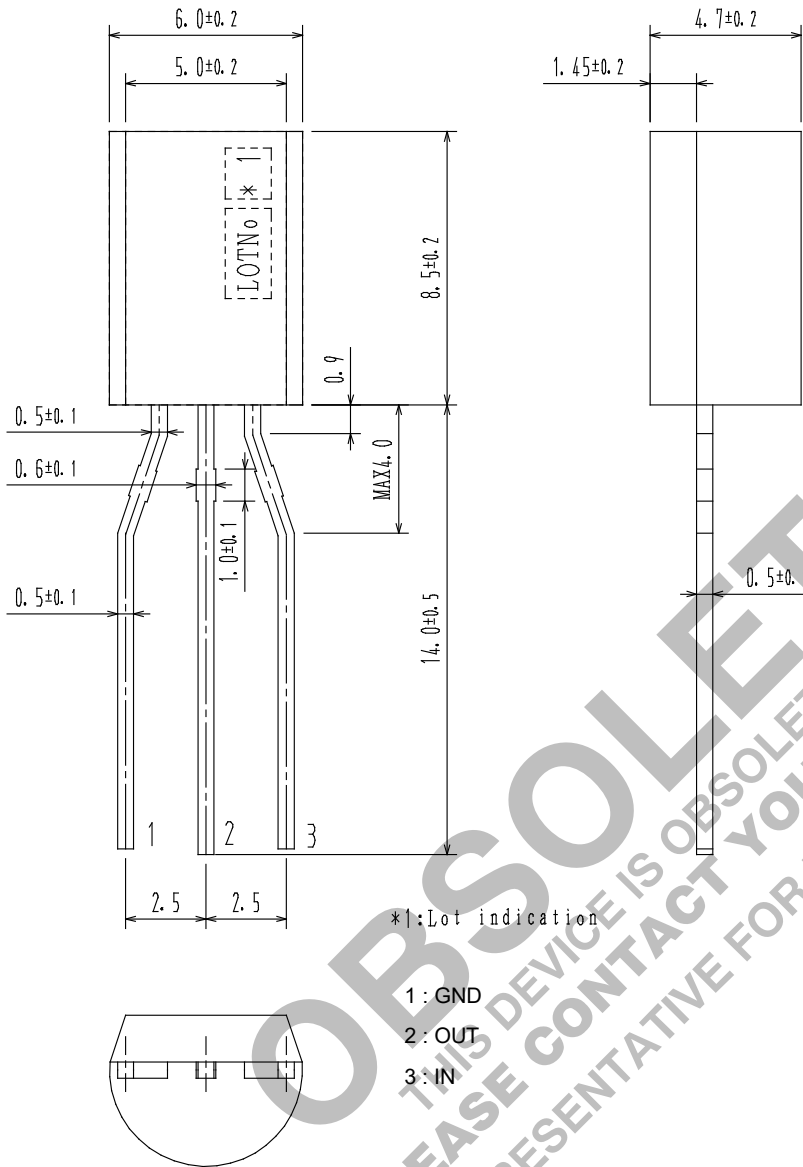

ORDERING INFORMATION

Device	Marking	Package	Shipping (Qty / Packing)
TND027MP-AZ	TND027	TO-92 3 8.5X6.0 / MP-WA (Pb-Free)	1,000 / Tape & Reel

† For information on tape and reel specifications, including part orientation and tape sizes, please refer to our Tape and Reel Packaging Specifications Brochure, BRD8011/D. http://www.onsemi.com/pub_link/Collateral/BRD8011-D.PDF

ON Semiconductor and the ON logo are registered trademarks of Semiconductor Components Industries, LLC (SCILLC) or its subsidiaries in the United States and/or other countries. SCILLC owns the rights to a number of patents, trademarks, copyrights, trade secrets, and other intellectual property. A listing of SCILLC's product/patent coverage may be accessed at www.onsemi.com/site/pdf/Patent-Marking.pdf. SCILLC reserves the right to make changes without further notice to any products herein. SCILLC makes no warranty, representation or guarantee regarding the suitability of its products for any particular purpose, nor does SCILLC assume any liability arising out of the application or use of any product or circuit, and specifically disclaims any and all liability, including without limitation special, consequential or incidental damages. "Typical" parameters which may be provided in SCILLC data sheets and/or specifications can and do vary in different applications and actual performance may vary over time. All operating parameters, including "Typicals" must be validated for each customer application by customer's technical experts. SCILLC does not convey any license under its patent rights nor the rights of others. SCILLC products are not designed, intended, or authorized for use as components in systems intended for surgical implant into the body, or other applications intended to support or sustain life, or for any other application in which the failure of the SCILLC product could create a situation where personal injury or death may occur. Should Buyer purchase or use SCILLC products for any such unintended or unauthorized application, Buyer shall indemnify and hold SCILLC and its officers, employees, subsidiaries, affiliates, and distributors harmless against all claims, costs, damages, and expenses, and reasonable attorney fees arising out of, directly or indirectly, any claim of personal injury or death associated with such unintended or unauthorized use, even if such claim alleges that SCILLC was negligent regarding the design or manufacture of the part. SCILLC is an Equal Opportunity/Affirmative Action Employer. This literature is subject to all applicable copyright laws and is not for resale in any manner.