

High Precision Rail-to-Rail Operational Amplifier

PRELIMINARY DATA

- Ultra low offset voltage: 60 μ V max
- Rail-to rail input/output voltage swing
- Operating from 2.7V to 5.5V
- High-speed: 2.2MHz
- Low consumption: 0.85mA
- Supply voltage rejection ratio: 85dB
- ESD protection 2kV
- Latch-up immunity
- Available in SOT23-5 micropackage

Description

The TS507 is a high performance rail-to-rail output amplifier with very low offset voltage. This amplifier uses a new trimming technique that yields ultra low offset voltages without any need for external nulling.

The circuit presents very stable electrical characteristics over the entire supply voltage range, and is particularly intended for professional and telecom applications.

The TS507 is housed in the space-saving 5 pins SOT23 package that makes it well suited for battery-powered systems. This micropackage simplifies the PC board design because of its ability to be placed in tight spaces (outside dimensions are: 2.8mm x 2.9mm)

Pin Connections (top view)

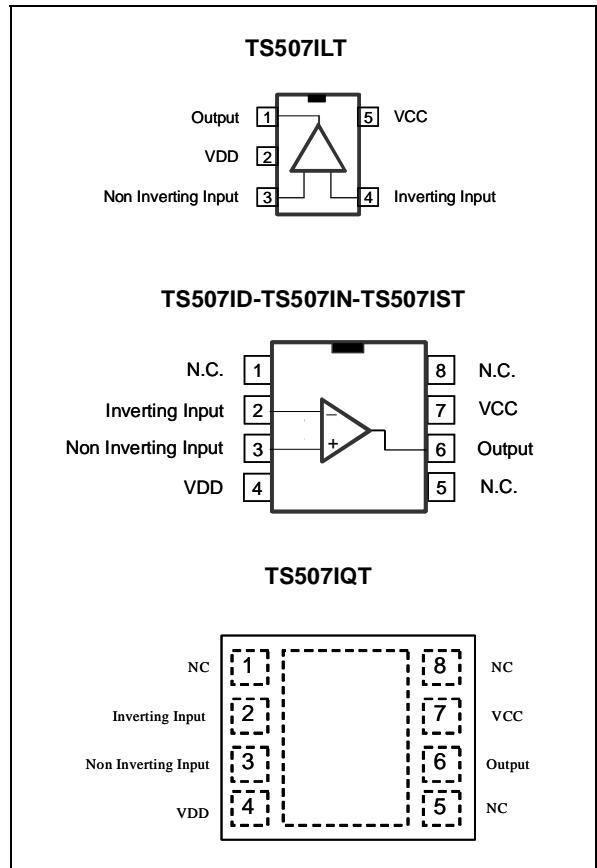

Applications

- Precision filters
- Transformer/line drivers
- Personal entertainments (CD players)
- Portable communication (cell phones, pagers)
- Instrumentation & sensing

Order Codes

Part Number	Temperature Range	Package	Packaging	Marking
TS507IN	-40, +125°C	DIP	Tube	
TS507ID/TS507IDT		DIP	Tube or Tape & Reel	
TS507IST		mini SO	Tape & Reel	
TS507ILT		SOT23-5	Tape & Reel	TBD
TS507IQT		DFN	Tape & Reel	

1 Absolute Maximum Ratings

Table 1: Key parameters and their absolute maximum ratings

Symbol	Parameter	Value	Unit
V _{CC}	Supply voltage ¹	6	V
V _{id}	Differential Input Voltage ²	±5.5	V
V _{in}	Input Voltage ³	Gnd to V _{CC}	V
T _{oper}	Operating Free Air Temperature Range	-40 to +125	°C
T _{stg}	Storage Temperature Range	-65 to +150	
T _j	Maximum Junction Temperature	150	°C
R _{thjc}	Thermal Resistance Junction to Case ⁴		°C/W
	SOT23-5	81	
	SO8	28	
	DIP8	80	
R _{thja}	Thermal Resistance Junction to Ambient - SOT23-5	256	°C/W
ESD	Human Body Model	2	kV
	Lead Temperature (soldering, 10sec)	260	°C

1) All voltage values, except differential voltage are with respect to network ground terminal.

2) Differential voltages are the non-inverting input terminal with respect to the inverting input terminal.

3) The magnitude of input and output voltages must never exceed V_{CC} +0.3V.

4) Short-circuits can cause excessive heating and destructive dissipation.

Table 2: Operating Conditions

Symbol	Parameter	Value	Unit
V _{CC}	Supply voltage	2.7 to 5.5	V
V _{icm}	Common Mode Input Voltage Range	V _{DD} -0.2 to V _{CC} +0.1	V

2 Electrical Characteristics

Table 3: $V_{CC}^+ = +5V$, $V_{DD}^- = 0V$, $T_{amb} = 25^\circ C$ (unless otherwise specified) - Operational Amplifier

Symbol	Parameter	Min.	Typ.	Max.	Unit
I_{CC}	Supply Current		0.85		mA
I_{ib}	Input Bias Current $T_{min} \leq T_{op} \leq T_{max}$		50 TBD	150	nA
R_i	Input Resistance, $f = 1kHz$		1		M Ω
V_{io}	Input Offset Voltage $0V \leq V_{CM} \leq 3.5V$ $T_{min} \leq T_{op} \leq T_{max}$ $0V \leq V_{CM} \leq 5V$ $T_{min} \leq T_{op} \leq T_{max}$		0	60 100 300 350	μV
ΔV_{io}	Input Offset Voltage Drift $T_{min} \leq T_{op} \leq T_{max}$		0.3		$\mu V/^\circ C$
I_{io}	Input Offset Current $T_{min} \leq T_{op} \leq T_{max}$		5	TBD TBD	nA
ΔI_{io}	Input Offset Current Drift $T_{min} \leq T_{op} \leq T_{max}$		0.08		$\frac{nA}{^\circ C}$
I_{os}	Output Short Circuit Current		50		mA
A_{vd}	Large Signal Voltage Gain $R_L = 2k\Omega$ $1V \leq V_{out} \leq 4V$		125		dB
GBP	Gain-bandwidth Product, $f = 100kHz$		2.2		MHz
e_n	Equivalent Input Noise Voltage, $f = 1kHz$ $R_s = 1k\Omega$		12		$\frac{nV}{\sqrt{Hz}}$
THD	Total Harmonic Distortion $A_v = 20dB$ $R_L = 2k\Omega$ $V_o = 2V_{pp}$ $f = 1kHz$		TDB		%
$\pm V_{opp}$	Output Voltage Swing $R_L = 2k\Omega$	TBD			V
V_{opp}	Large Signal Voltage Swing $R_L = 10k\Omega$ $f = 10kHz$		TBD		V_{pp}
SR	Slew Rate Unity Gain, $R_L = 2k\Omega$		0.65		V/ μs
PSRR	Power Supply Rejection Ratio		100		dB
CMRR	Common Mode Rejection Ratio $V_{ic} = 0V$ to $3.5V$ $V_{ic} = 0V$ to $5V$		125 94		dB

3 Package Mechanical Data

3.1 DIP-8 Package

Plastic DIP-8 MECHANICAL DATA						
DIM.	mm.			inch		
	MIN.	TYP	MAX.	MIN.	TYP.	MAX.
A		3.3			0.130	
a1	0.7			0.028		
B	1.39		1.65	0.055		0.065
B1	0.91		1.04	0.036		0.041
b		0.5			0.020	
b1	0.38		0.5	0.015		0.020
D			9.8			0.386
E		8.8			0.346	
e		2.54			0.100	
e3		7.62			0.300	
e4		7.62			0.300	
F			7.1			0.280
I			4.8			0.189
L		3.3			0.130	
Z	0.44		1.6	0.017		0.063

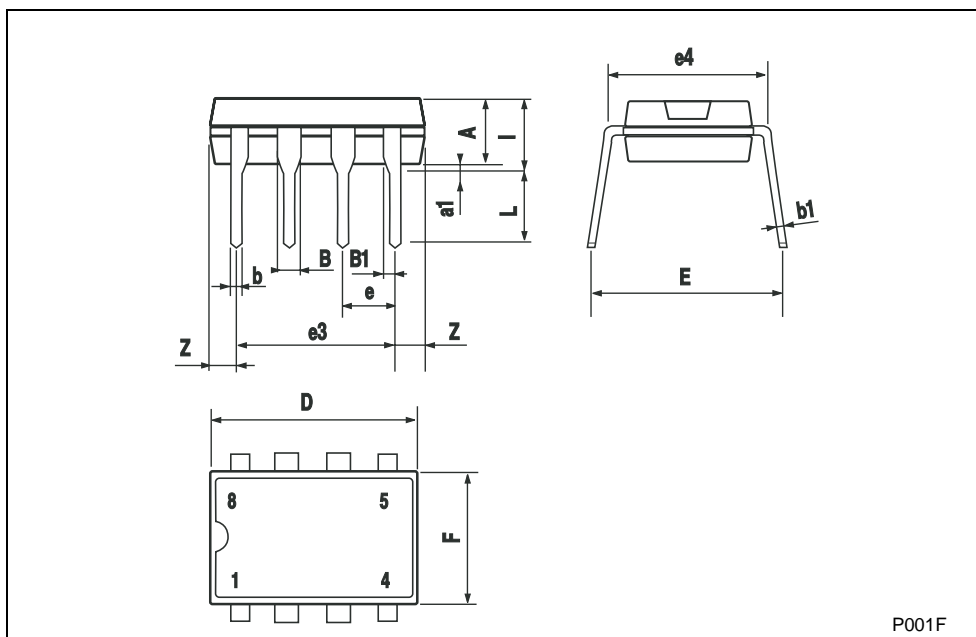

3.2 SO-8 Package

SO-8 MECHANICAL DATA

DIM.	mm.			inch		
	MIN.	TYP.	MAX.	MIN.	TYP.	MAX.
A	1.35		1.75	0.053		0.069
A1	0.10		0.25	0.04		0.010
A2	1.10		1.65	0.043		0.065
B	0.33		0.51	0.013		0.020
C	0.19		0.25	0.007		0.010
D	4.80		5.00	0.189		0.197
E	3.80		4.00	0.150		0.157
e		1.27			0.050	
H	5.80		6.20	0.228		0.244
h	0.25		0.50	0.010		0.020
L	0.40		1.27	0.016		0.050
k	8° (max.)					
ddd			0.1			0.04

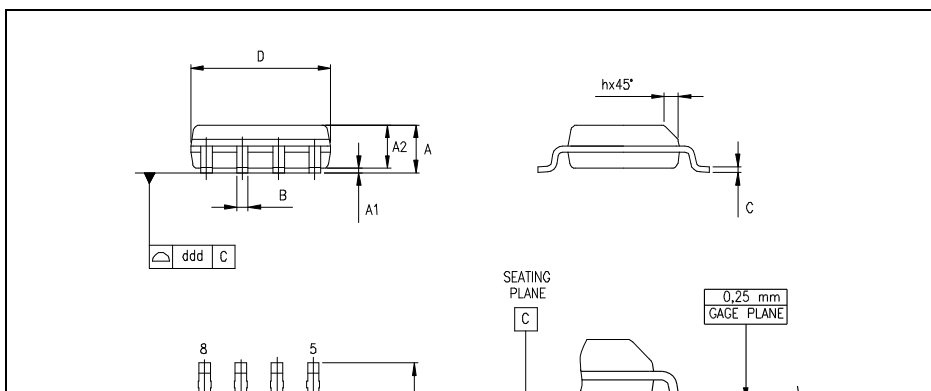

3.3 Mini SO-8 Package

miniSO-8 MECHANICAL DATA

DIM.	mm.			inch		
	MIN.	TYP	MAX.	MIN.	TYP.	MAX.
A			1.1			0.043
A1	0.05	0.10	0.15	0.002	0.004	0.006
A2	0.78	0.86	0.94	0.031	0.031	0.037
b	0.25	0.33	0.40	0.010	0.13	0.013
c	0.13	0.18	0.23	0.005	0.007	0.009
D	2.90	3.00	3.10	0.114	0.118	0.122
E	4.75	4.90	5.05	0.187	0.193	0.199
E1	2.90	3.00	3.10	.0114	0.118	0.122
e		0.65			0.026	
K	0°		6°	0°		6°
L	0.40	0.55	0.70	0.016	0.022	0.028
L1			0.10			0.004

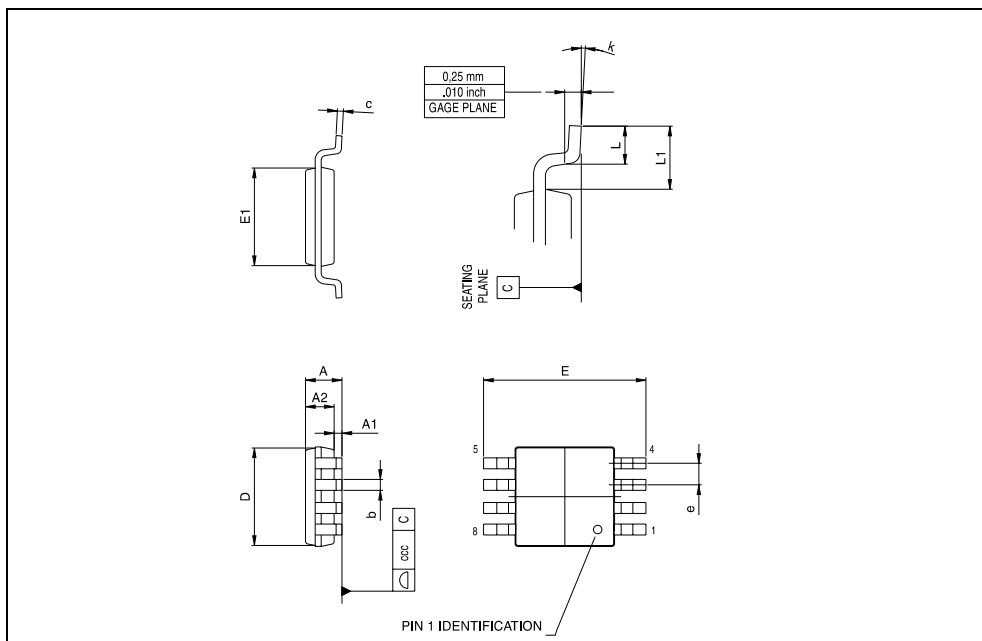

3.4 SOT23-5 Package

SOT23-5L MECHANICAL DATA

DIM.	mm.			mils		
	MIN.	TYP.	MAX.	MIN.	TYP.	MAX.
A	0.90		1.45	35.4		57.1
A1	0.00		0.15	0.0		5.9
A2	0.90		1.30	35.4		51.2
b	0.35		0.50	13.7		19.7
C	0.09		0.20	3.5		7.8
D	2.80		3.00	110.2		118.1
E	2.60		3.00	102.3		118.1
E1	1.50		1.75	59.0		68.8
e		0.95			37.4	
e1		1.9			74.8	
L	0.35		0.55	13.7		21.6

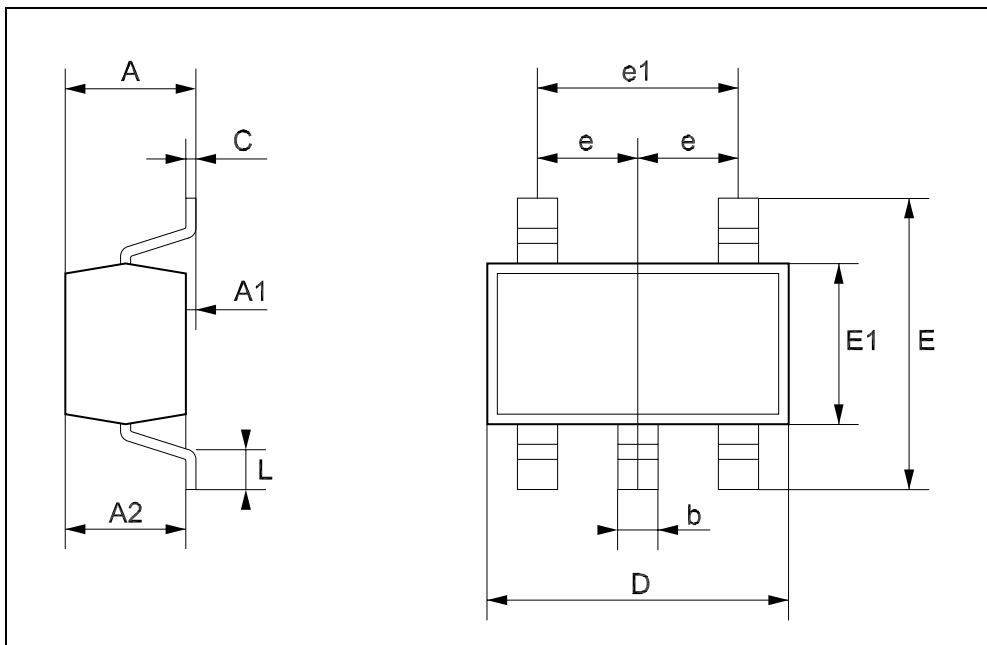

3.5 DFN8 Package

DFN8 (3x3) MECHANICAL DATA

DIM.	mm.			inch		
	MIN.	TYP.	MAX.	MIN.	TYP.	MAX.
A	0.80	0.90	1.00	31.5	35.4	39.4
A1		0.02	0.05		0.8	2.0
A2		0.70			27.6	
A3		0.20			7.9	
b	0.18	0.23	0.30	7.1	9.1	11.8
D	2.875	3.00	3.125		118.1	
D2	2.23	2.38	2.48	87.8	93.7	97.7
E	2.875	3.00	3.125		118.1	
E2	1.49	1.64	1.74	58.7	64.6	68.5
e		0.50			19.7	
L	0.30	0.40	0.50	11.8	15.7	19.7

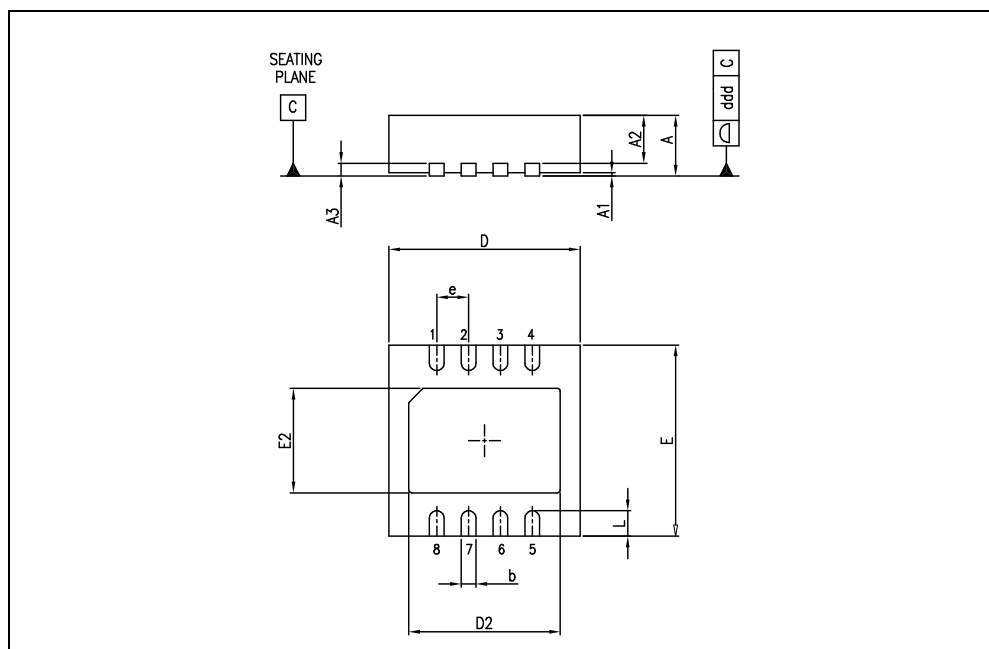

4 Revision History

Date	Revision	Description of Changes
01 Oct 2004	1	First Release

Information furnished is believed to be accurate and reliable. However, STMicroelectronics assumes no responsibility for the consequences of use of such information nor for any infringement of patents or other rights of third parties which may result from its use. No license is granted by implication or otherwise under any patent or patent rights of STMicroelectronics. Specifications mentioned in this publication are subject to change without notice. This publication supersedes and replaces all information previously supplied. STMicroelectronics products are not authorized for use as critical components in life support devices or systems without express written approval of STMicroelectronics.

The ST logo is a registered trademark of STMicroelectronics
All other names are the property of their respective owners

© 2004 STMicroelectronics - All rights reserved

STMicroelectronics group of companies

Australia - Belgium - Brazil - Canada - China - Czech Republic - Finland - France - Germany - Hong Kong - India - Israel - Italy - Japan - Malaysia - Malta - Morocco - Singapore - Spain - Sweden - Switzerland - United Kingdom - United States of America

www.st.com