

## REMOTE CONTROLLER WITH FIVE FUNCTIONS

### DESCRIPTION

The TX-2B/RX-2B is a pair of CMOS LSIs designed for remote controlled car applications. The TX-2B/RX-2B has five control keys for controlling the motions (i.e. forward, backward, rightward, leftward and the turbo function ) of the remote controlled car.

### FEATURES

- \* Wide operating voltage range ( $V_{CC}=1.5\sim 5.0V$ )
- \* Low stand-by current
- \* Auto-power-off function for TX-2B
- \* Few external components are needed

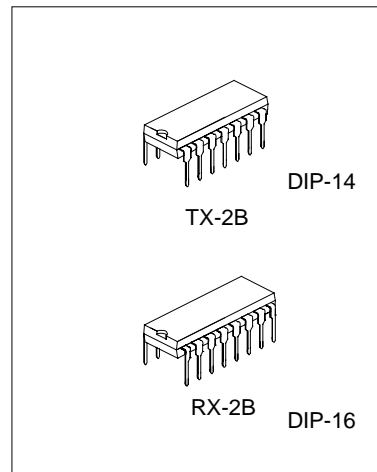

### ORDERING INFORMATION

Part No.	Package
TX-2B	DIP-14-300-2.54
RX-2B	DIP-16-300-2.54

### BLOCK DIAGRAM

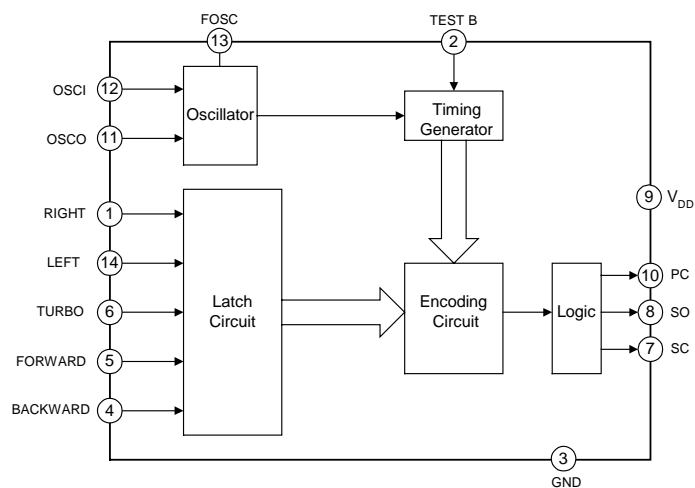

TRANSMITTER TX-2B Block Diagram

**BLOCK DIAGRAM**

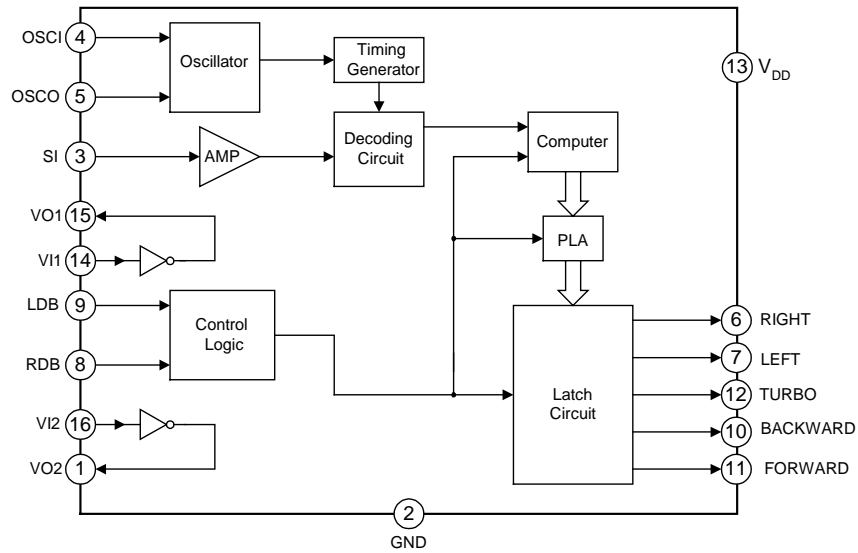

**RECEIVER RX-2B Block Diagram**

**PIN CONFIGURATION**

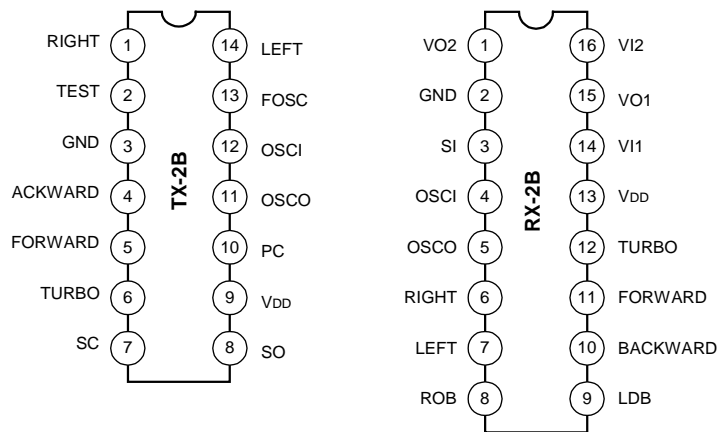

## ABSOLUTE MAXIMUM RATINGS

Characteristic	Symbol	Value	Unit
Supply Voltage	VDD	0.3~5.0	V
Input / Output Voltage	VIN, VOUT	GND-0.3~VDD+0.3	V
Operating Temperature	TOPR	-10~65	°C
Storage Temperature	Tstg	-25~125	°C

## ELECTRICAL CHARACTERISTICS

1. **TX-2B** (VDD=4.0V, Fosc=128KHz, Tamb =25°C, unless otherwise specified.)

Characteristic	Symbol	Min	Typ	Max	Unit
Operating Voltage	VDD	1.5	4.0	5.0	V
Operating Current	IDD	--	--	2.0	mA
Stand-By Current	ISTB	--	--	10	μA
DC O/P Driving Current	Idrive	5	--	--	mA
AC O/P Driving Current	Idrive	5	--	--	mA
AC O/P Frequency	Faudio	0.5	--	1.0	kHz

2. **RX-2B** (VDD=4.0V, Fosc=128KHz, Tamb=25°C, unless otherwise specified.)

characteristic	Symbol	Min	Typ	Max	Unit
Operating Voltage	VDD	1.5	4.0	5.0	V
Operating Current	IDD	--	--	3.0	mA
O/P Driving Current	Idrive	1	--	--	mA
O/P Sinking Current	Isink	1	--	--	mA
Effect Decoding Frequency Variation	Ftolerance	-20	--	20	%

## PIN DESCRIPTION

### 1. TX-2B

Pin No.	Symbol	Description
1	RIGHT	The rightward function will be selected, if this pin is connected to GND
2	TEST	This pin is used for testing mode
3	GND	Negative power supply
4	BACKWARD	The backward function will be selected, if this pin is connected to GND
5	FORWARD	The forward function will be selected, if this pin is connected to GND

(To be continued)

— HANGZHOU SILAN MICROELECTRONICS JOINT-STOCK CO.,LTD —

Rev: 1.0 2002.03.29

(Continued)

Pin No.	Symbol	Description
6	TURBO	The turbo function will be selected if this pin is connected to GND
7	SC	Output pin of the encoding signal with carrier frequency
8	SO	Output pin of the encoding signal without carrier frequency
9	VDD	Positive power supply
10	PC	Power control output pin
11	OSCO	Oscillator output pin
12	OSCI	Oscillator input pin
13	FOSC	This pin is used for testing mode
14	LEFT	The leftward function will be selected, if this pin is connected to GND

**2. RX-2B**

Pin No.	Symbol	Description
1	VO2	Inverter 2 output pin for power amplify
2	GND	Negative power supply
3	SI	Input pin of the encoding signal
4	OSCI	Oscillator input pin
5	OSCO	Oscillator output pin
6	RIGHT	Rightward output pin
7	LEFT	Leftward output pin
8	ROB	Rightward function disable, if this pin is connected to GND
9	LDB	Leftward function disable, if this pin is connected to GND
10	BACKWARD	Backward output pin
11	FORWARD	Forward output pin
12	TURBO	TURBO output pin
13	VDD	Positive power supply
14	VI1	Inverter 1 input pin for power amplify
15	VO1	Inverter 1 output pin for power amplify
16	VI2	Inverter 2 input pin for power amplify

**CODE FORMAT**

**1. ENCODE RULE**

(A).Bit Format (W1 is used for function codes,W2 for start codes)

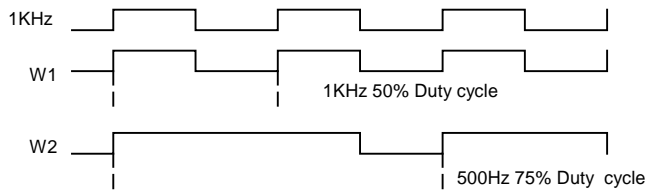

(B).Date Format

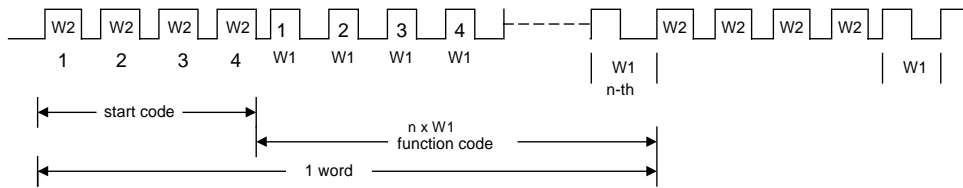
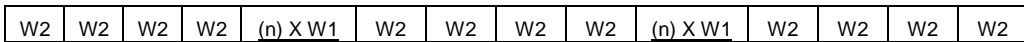

Number Of Function Code (N) W1	Function Key	Decode Result
4		End Code
10	Forward	Forward
16	Forward & Turbo	Forward
22	Turbo	Turbo
28	Turbo & Forward & Left	Forward & Left
34	Turbo & Forward & Right	Forward & Right
40	Backward	Backward
46	Backward & Right	Backward & Right
52	Backward & Left	Backward & Left
58	Left	Left
64	Right	Right

**2. ENCODE/DECODE TIMING**

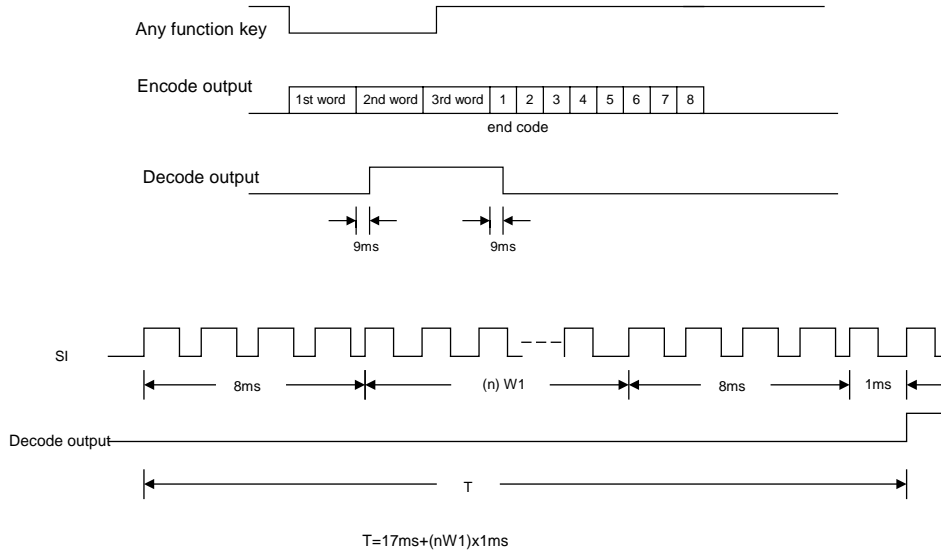

**TESTING CIRCUIT**

(The oscillator frequency of TX-2B, RX-2B is 128KHz, the oscillator resistor is 160KΩ and 250KΩ respectively)

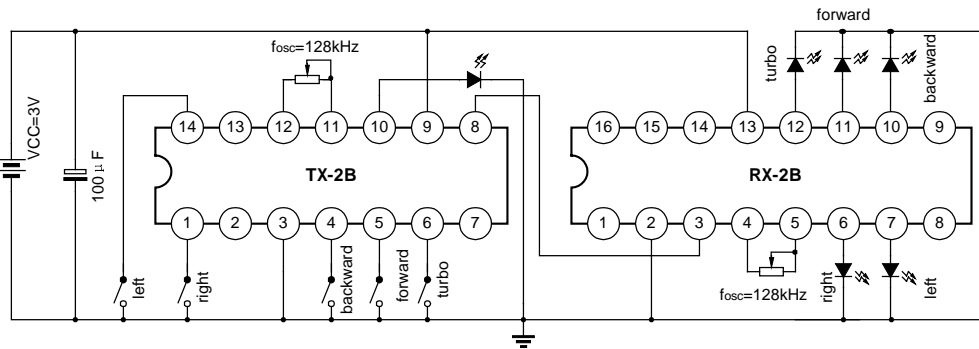

**TYPICAL APPLICATION CIRCUIT**

*TRANSMITTER*

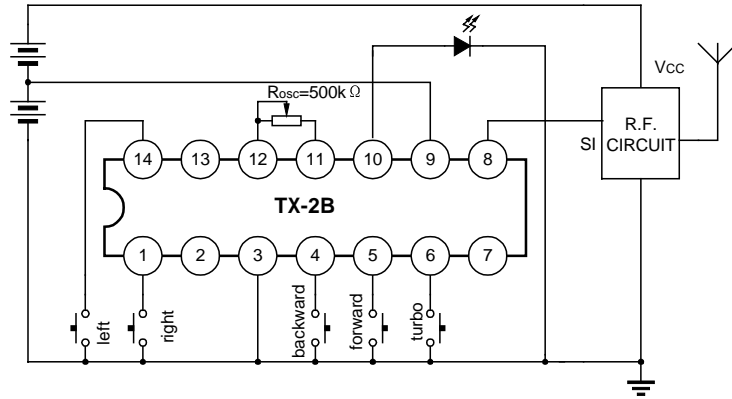

*RECEIVER*

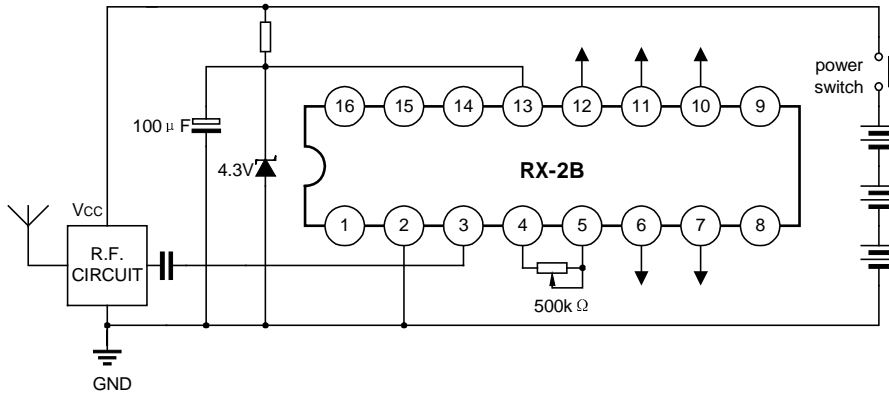

**INFRARED APPLICATION CIRCUIT**

*TRANSMITTER*

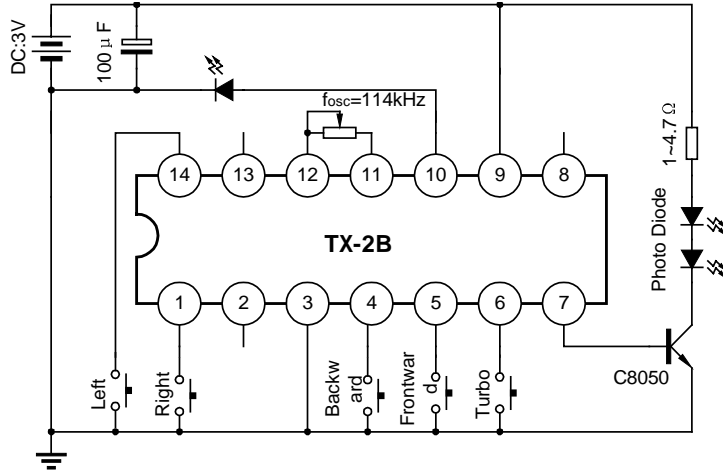

*RECEIVER*

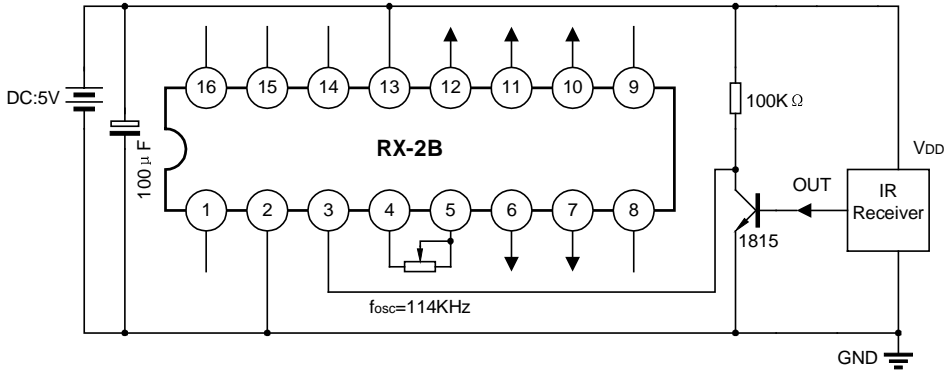



**RECOMMENDED APPLICATION CIRCUIT**

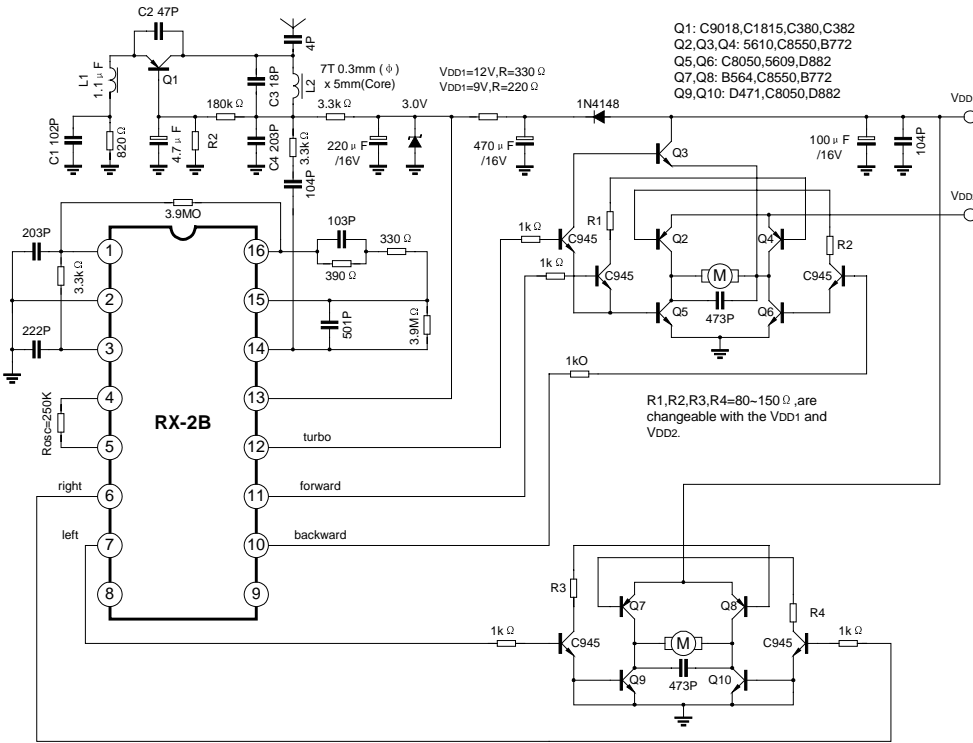
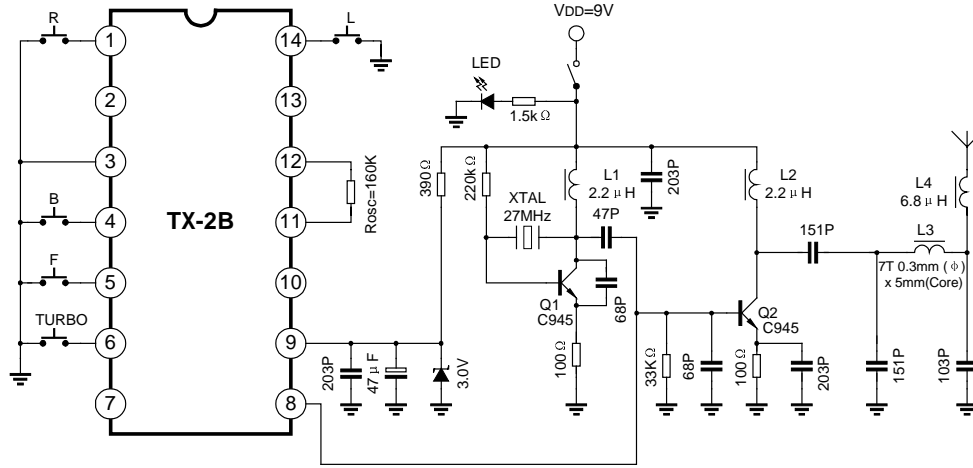

- Q1: C9018, C1815, C380, C382
- Q2, Q3, Q4: 5610, C8550, B772
- Q5, Q6: C8050, 5609, D882
- Q7, Q8: B564, C8550, B772
- Q9, Q10: D471, C8050, D882

**PACKAGE OUTLINE**

