



Features

- Full-wave Current Sensing
- Mains Supply Variation Compensated
- Programmable Load-current Limitation with Over- and High-load Output
- Variable Soft Start
- Voltage and Current Synchronization
- Automatic Retriggering Switchable
- Triggering Pulse Typically 125 mA
- Internal Supply-voltage Monitoring
- Current Requirement ≤ 3 mA
- Temperature-compensated Reference Voltage



Applications

- Advanced Motor Control
- Grinder
- Drilling Machine

Phase-control IC with Current Feedback and Overload Protection

U2010B

1. Description

The U2010B is designed as a phase-control circuit in bipolar technology for motor control applications with load-current feedback and overload protection. It enables load-current detection and has a soft-start function as well as reference voltage output.

Figure 1-1. Block Diagram

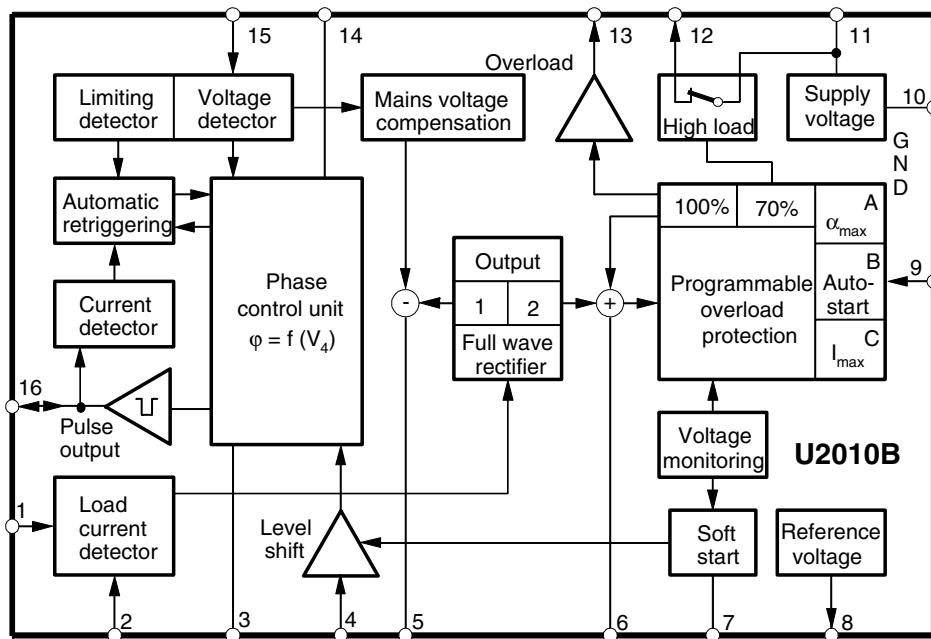
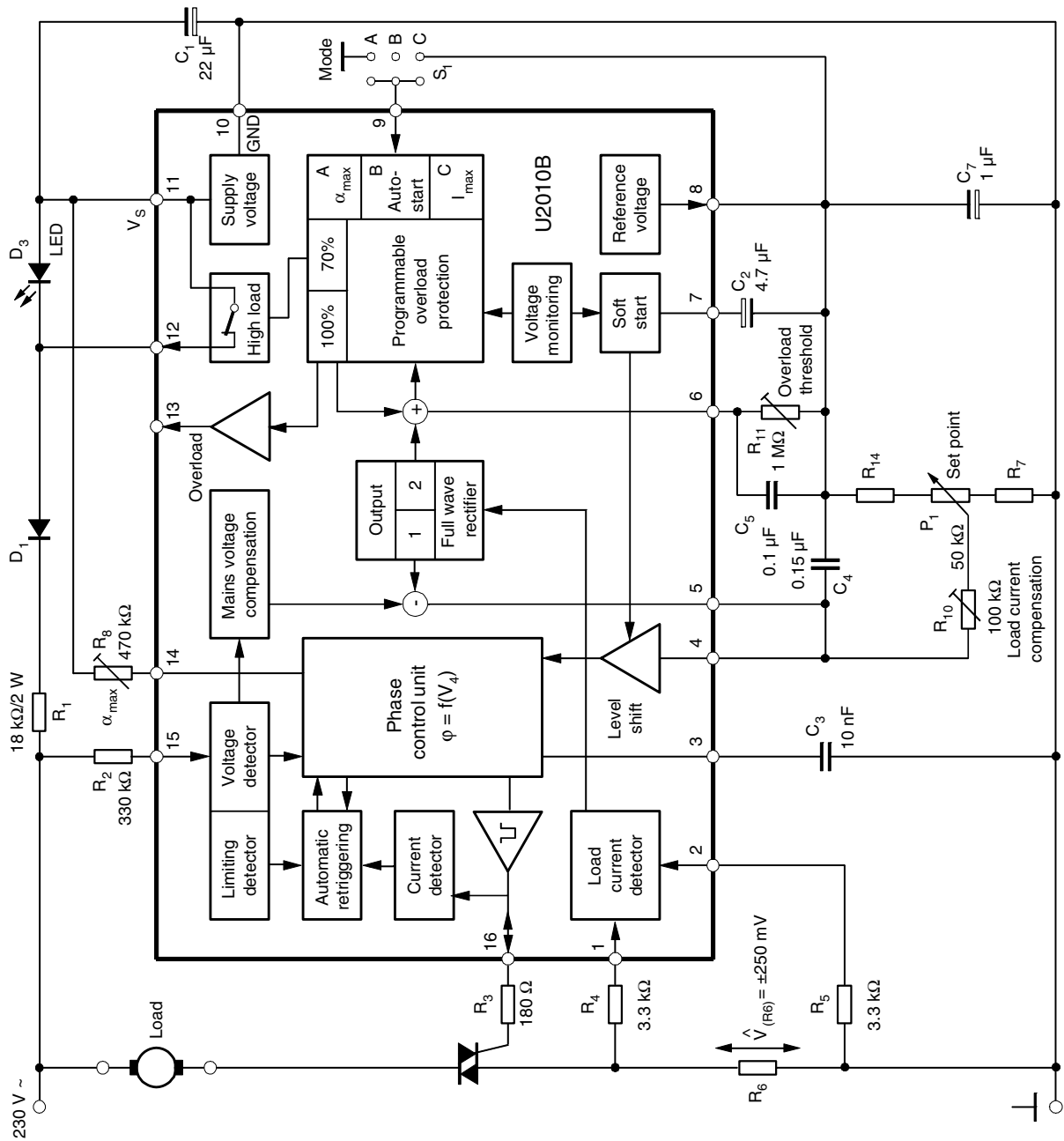

Figure 1-2. Block Diagram with External Circuit



2. Pin Configuration

Figure 2-1. Pinning DIP16/SO16

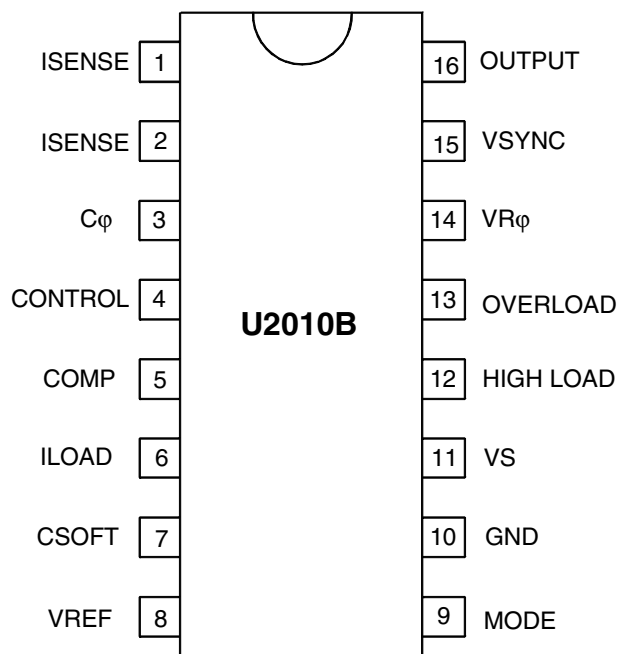

Table 2-1. Pin Description

Pin	Symbol	Function
1	ISENSE	Load current sensing
2	ISENSE	Load current sensing
3	$C\phi$	Ramp voltage
4	CONTROL	Control input
5	COMP	Compensation output
6	ILOAD	Load current limitation
7	CSOFT	Soft start
8	VREF	Reference voltage
9	MODE	Mode selection
10	GND	Ground
11	VS	Supply voltage
12	HIGH LOAD	High load indication
13	OVERLOAD	Overload indication
14	$VR\phi$	Ramp current adjust
15	VSYNC	Voltage synchronization
16	OUTPUT	Trigger output

3. General Description

3.1 Mains Supply

The U2010B contains voltage limiting and can be connected with the mains supply via D_1 and R_1 . Supply voltage – between pin 10 and pin 11 – is smoothed by C_1 .

In the case of $V_6 \leq 70\%$ of the overload threshold voltage, pins 11 and 12 are connected internally whereby $V_{sat} \leq 1.2 \text{ V}$. When $|V_6| \geq |V_{T70}|$, the supply current flows across D_3 .

The series resistance R_1 can be calculated as follows:

$$R_{1\max} = \frac{V_{\text{mains}} - V_{S\max}}{2 \times I_{\text{tot}}}$$

where:

V_{mains} = Mains supply voltage

$V_{S\max}$ = Maximum supply voltage

I_{tot} = Total current consumption = $I_{S\max} + I_x$

$I_{S\max}$ = Maximum current consumption of the IC

I_x = Current consumption of the external components

3.2 Voltage Monitoring

When the voltage is built up, uncontrolled output pulses are avoided by internal voltage monitoring. Apart from that, all latches in the circuit (phase control, load limit regulation) are reset and the soft-start capacitor is short-circuited. This guarantees a specified start-up behavior each time the supply voltage is switched on or after short interruptions of the mains supply. Soft start is initiated after the supply voltage has been built up. This behavior guarantees a gentle start-up for the motor and automatically ensures the optimum run-up time.

3.3 Phase Control

The function of the phase control is mainly identical to the well-known IC U211B. The phase angle of the trigger pulse is derived by comparing the ramp voltage V_3 , which is mains-synchronized by the voltage detector, with the set value on the control input, pin 4. The slope of the ramp is determined by C_ϕ and its charging current I_ϕ . The charging current can be varied using R_ϕ at pin 14. The maximum phase angle, α_{\max} , can also be adjusted by using R_ϕ (minimum current flow angle ϕ_{\min}), see [Figure 7-1 on page 10](#).

When the potential on pin 3 reaches the set point level of pin 4, a trigger pulse width, t_p , is determined from the value of C_ϕ ($t_p = 9 \mu\text{s/nF}$). At the same time, a latch is set with the output pulse as long as the automatic retriggering has not been activated. When this happens, no more pulses can be generated in that half cycle. The control input at pin 4 (with respect to pin 10) has an active range from V_8 to -1 V . When $V_4 = V_8$, then the phase angle is at its maximum, α_{\max} , i.e., the current flow angle is minimum. The minimum phase angle, α_{\min} , is set with $V_4 \geq -1 \text{ V}$.

3.4 Automatic Retriggering

The current-detector circuit monitors the state of the triac after triggering by measuring the voltage drop at the triac gate. A current flow through the triac is recognized when the voltage drop exceeds a threshold level of typically 40 mV.

If the triac is quenched within the relevant half-wave after triggering (for example owing to low load currents before or after the zero crossing of the current wave, or for commutator motors, owing to brush lifters), the automatic retriggering circuit ensures immediate retriggering, if necessary with a high repetition rate, t_{pp}/t_p , until the triac remains reliably triggered.

3.5 Current Synchronization

Current synchronization fulfils two functions:

- Monitoring the current flow after triggering.
In case the triac extinguishes again or does not switch on, automatic triggering is activated until the triggering is successful.
- Avoiding triggering due to an inductive load.
In the case of inductive load operation, the current synchronization ensures that in the new half wave, no pulse will be enabled as long as there is a current available from the previous half wave, which flows from the opposite polarity to the actual supply voltage.

The current synchronization as described above is a special feature of the U2010B. The device evaluates the voltage at the pulse output between gate and reference electrode of the triac. As a result, no separate current synchronization input with specified series resistance is necessary.

3.6 Voltage Synchronization with Mains Voltage Compensation

The voltage detector synchronizes the reference ramp with the mains supply voltage. At the same time, the mains-dependent input current at pin 15 is shaped and rectified internally. This current activates the automatic retriggering and at the same time is available at pin 5. By suitable dimensioning, it is possible to obtain the specified compensation effect. Automatic retriggering and mains voltage compensation are not activated until $|V_{15-10}|$ increases to 8 V. The resistance R_{sync} defines the width of the zero voltage cross over pulse, synchronization current, and hence the mains supply voltage compensation current.

Figure 3-1. Suppression of Mains Voltage Compensation and Automatic Retrigger

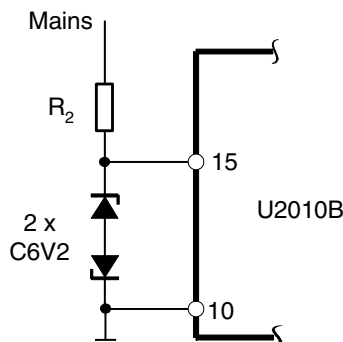

If the mains voltage compensation and the automatic retriggering are not required, both functions can be suppressed by limiting $|V_{15-10}| \leq 7$ V, see [Figure 3-1](#).

3.7 Load-current Compensation

The circuit continuously measures the load current as a voltage drop at resistance R_6 . The evaluation and use of both half waves results in a quick reaction to load-current change. Due to the voltage at resistance R_6 , there is a difference between both input currents at pins 1 and 2. This difference controls the internal current source, whose positive current values are available at pins 5 and 6. The output current generated at pin 5 contains the difference from the load-current detection and from the mains voltage compensation, see [Figure 1-2 on page 2](#).

The efficient impedance of the set-point network generates a voltage at pin 4. A current, flowing out of pin 5 through R_{10} , modulates this voltage. An increase of mains voltage causes the increase of control angle α , an increase of load current results in a decrease in the control angle. This avoids a decrease in revolution by increasing the load as well as an increase of revolution by the increment of the mains supply voltage.

3.8 Load-current Limitation

The total output load current is available at pin 6. It results in a voltage drop across R_{11} . When the potential of the load current reaches about 70% of the threshold value (V_{T70}), i.e., about 4.35 V at pin 6, it switches the high-load comparator and opens the switch between pins 11 and 12. By using an LED between these pins (11 and 12), a high-load indication can be realized.

If the potential at pin 6 increases to about 6.2 V ($= V_{T100}$), it switches the overload comparator. The result is programmable at pin 9 (operation mode).

3.8.1 Mode Selection

- a) α_{\max} ($V_9 = 0$)
 In this mode of operation, pin 13 switches to $-V_S$ (pin 11) and pin 6 to GND (pin 10) after V_6 has reached the threshold V_{T100} . A soft-start capacitor is then shorted and the control angle is switched to α_{\max} . This position is maintained until the supply voltage is switched off. The motor can be started again with the soft-start function when the power is switched on again. As the overload condition switches pin 13 to pin 11, it is possible to use a smaller control angle, α_{\max} , by connecting a further resistance between pins 13 and 14.
- b) Auto start (pin 9 – open), see [Figure 7-8 on page 12](#)
 The circuit behaves as described above, with the exception that pin 6 is not connected to GND. If the value of V_6 decreases to 25% of the threshold value (V_{T25}), the circuit becomes active again with soft start.
- c) I_{\max} ($V_9 = V_8$), see [Figure 7-10 on page 13](#)
 When V_6 has reached the maximum overload threshold value (i.e., $V_6 = V_{T100}$), pin 13 is switched to pin 8 (V_{Ref}) through the resistance R ($= 2 \text{ k}\Omega$) without the soft-start capacitor discharging at pin 7. With this mode of operation, direct load-current control (I_{\max}) is possible.

4. Absolute Maximum Ratings

Stresses beyond those listed under “Absolute Maximum Ratings” may cause permanent damage to the device. This is a stress rating only and functional operation of the device at these or any other conditions beyond those indicated in the operational sections of this specification is not implied. Exposure to absolute maximum rating conditions for extended periods may affect device reliability.

Reference point pin 10, unless otherwise specified.

Parameters	Pin	Symbol	Value	Unit
Sink current $t \leq 10 \mu\text{s}$	11	$-I_S$	30	mA
	11	$-i_s$	100	mA
Synchronous currents $t \leq 10 \mu\text{s}$	15	$\pm I_{\text{syncV}}$	5	mA
	15	$\pm i_{\text{syncV}}$	5	mA
Phase Control				
Control voltage	4, 8	$-V_I$	$0 - V_8$	V
Input current	4	$\pm I_I$	500	μA
Charging current	14	$-I_{\uparrow\text{max}}$	0.5	mA
Soft Start				
Input voltage	7, 8	$-V_I$	$0 - V_8$	V
Pulse Output				
Input voltage	16	$+V_I$	2	V
		$-V_I$	V_{11}	V
Reference Voltage Source				
Output current $t \leq 10 \mu\text{s}$	8	I_o	10	mA
	8	I_o	30	mA
Load-current Sensing				
Input currents	1, 2	$\pm I_i$	1	mA
Input voltages	5, 6	$-V_i$	$0 - V_8$	V
Overload output	13	I_L	1	mA
High-load output $t \leq 10 \mu\text{s}$	12	I_L	30	mA
	12	I_L	100	mA
Storage temperature range		T_{stg}	-40 to +125	$^{\circ}\text{C}$
Junction temperature range		T_j	125	$^{\circ}\text{C}$
Ambient temperature range		T_{amb}	-10 to +100	$^{\circ}\text{C}$

5. Thermal Resistance

Parameters		Symbol	Value	Unit
Junction ambient	DIP16	R_{thJA}	120	K/W
	SO16 on p.c.	R_{thJA}	180	K/W
	SO16 on ceramic	R_{thJA}	100	K/W

6. Electrical Characteristics

Parameters	Test Conditions	Pin	Symbol	Min.	Typ.	Max.	Unit
Supply		11					
Supply-voltage limitation	$-I_S = 3.5 \text{ mA}$ $-I_S = 30 \text{ mA}$		$-V_S$ $-V_S$	14.5 14.6		16.5 16.8	V V
Current requirement	$-V_S = 13.0 \text{ V}$	1, 2, 8 and 15 open	$-I_S$			3.6	mA
Reference Voltage Source		8					
Reference voltage	$I_L = 10 \mu\text{A}$ $I_L = 2.5 \text{ mA}$		$-V_{\text{Ref}}$ $-V_{\text{Ref}}$	8.6 8.4	8.9 8.8	9.2 9.1	V V
Temperature coefficient	$I_S = 2.5 \text{ mA}$ $I_S = 10 \mu\text{A}$		$TC_{V_{\text{Ref}}}$ $TC_{V_{\text{Ref}}}$		-0.004 +0.006		%/K %/K
Voltage Monitoring		11					
Turn-on threshold			$-V_{\text{Son}}$		11.3	12.3	V
Phase Control Synchronization		15					
Input current	Voltage sync.		$\pm I_{\text{syncV}}$	0.15		2	mA
Voltage limitation	$\pm I_L = 2 \text{ mA}$		$\pm V_{\text{syncV}}$	8.0	8.5	9.0	V
Input current	Current synchronization	16	$\pm I_{\text{syncI}}$	3		30	μA
Reference Ramp, see Figure 7-1 on page 10							
Charging current		14	$-I_\phi$	1		100	μA
Start voltage		3	$-V_{\text{max}}$	1.85	1.95	2.05	V
Temperature coefficient of start voltage		3	TC_R		-0.003		%/K
Final voltage		3	$-V_{\text{min}}$	$(V_8 \pm 200 \text{ mV})$			
R_ϕ - reference voltage	$I_\phi = 10 \mu\text{A}$	11, 14	$V_{R\phi}$	0.96	1.02	1.10	V
Temperature coefficient	$I_\phi = 10 \mu\text{A}$ $I_\phi = 1 \mu\text{A}$	14	$TC_{V_{R\phi}}$ $TC_{V_{R\phi}}$		0.03 0.06		%/K %/K
Pulse output current	$V_{16} = -1.2 \text{ V}$, Figure 7-2 on page 10	16	I_0	100	125	150	mA
Output pulse width	$V_S = V_{\text{limit}}$ $C_3 = 3.3 \text{ nF}$, see Figure 7-3 on page 10	16	t_p		30		μs
Automatic Retriggering							
Repetition rate	$I_{15} \geq 150 \mu\text{A}$		t_{pp}	3	5	7.5	t_p
Threshold voltage		16	$\pm V_I$	20		60	mV
Soft Start, see Figure 7-4 and Figure 7-5 on page 11		7					
Starting current	$V_7 = V_8$		$-I_0$	5	10	15	μA
Final current	$V_{7-10} = -1\text{V}$		$-I_0$	15	25	40	μA
Discharge current			$+I_0$	0.5			mA
Output current		4	$+I_0$	0.2		2	mA
Mains Voltage Compensation, see Figure 7-6 on page 11		15					
Transfer gain	I_{15}/I_5	15/5 (1 and 2 open)	G_i	14	17	20	
Output offset current	$V_{(R6)} = V_{15} = V_5 = 0$		$\pm I_0$			2	μA

6. Electrical Characteristics (Continued)

Parameters	Test Conditions	Pin	Symbol	Min.	Typ.	Max.	Unit
Load-current Detection, $R_1 = R_2 = 3\text{ k}\Omega$, $V_{15} = 0$, $V_5 = V_6 = V_8$, see Figure 7-7 on page 12							
Transfer gain	$I_5/150\text{ mV}$, $I_6/150\text{ mV}$		G_I	0.28	0.32	0.37	$\mu\text{A/mV}$
Output offset currents		5, 6, 7, 8	$-I_0$	0	3	6	μA
Reference voltage	$I_1, I_2 = 100\text{ }\mu\text{A}$	1, 2	$-V_{\text{Ref}}$	300		400	mV
Shunt voltage amplitude	See Figure 1-2 on page 2		$\pm V_{(R6)}$			250	mV
Load-current Limitation 6, 7, 8							
High load switching	Threshold V_{T70} Figure 7-9 on page 12		V_{T70}	4	4.35	4.7	V
Overload switching	Threshold V_{T100} Figure 7-10 on page 13 Figure 7-11 on page 13		V_{T100}	5.8	6.2	6.6	V
Restart switching	Threshold V_{T25} Figure 7-8 on page 12		V_{T25}	1.25	1.55	1.85	V
Input current	Enquiry mode		I_i			1	μA
Output impedance	Switching mode		R_0	2	4	8	$\text{k}\Omega$
Programming Input, see Figure 1-2 on page 2 9							
Input voltage - auto-start		9 open	$-V_9$	3.8	4.3	4.7	V
Input current	$V_9 = 0$ (a_{max})		$-I_9$	5	10	20	μA
	$V_9 = V_8$ (I_{max})		I_9	5	10	20	μA
High Load Output, V_{T70}, see Figure 7-9 on page 12, $I_{12} = -3\text{mA}$ 11, 12							
Saturation voltages	$V_{6-8} \leq V_{T70}$		V_{sat}	0.5	0.75	1.0	V
	$V_{6-8} \geq V_{T70}$		V_{lim}	7.0	7.4	7.8	V
Overload Output, V_{T100}, $V_9 = \text{Open}$ or $V_9 = V_{10}$, see Figure 7-10 on page 13							
Leakage current	$V_{6-8} \leq V_{T25}$, $V_{13} = (V_{11}+1)\text{V}$	13	I_{lk}			0.5	μA
Saturation voltages	$V_{6-8} \geq V_{T100}$, $I_{13} = 10\text{ }\mu\text{A}$	11, 12, 13	V_{sat}			0.1	V
Output current, maximum load	$V_9 = V_8$, see Figure 7-10 on page 13	13	I_{13}			1	mA
Leakage current	$V_6 \leq V_{T100}$	13	I_{lk}			4	μA
Output impedance	Open collector, $V_6 \geq V_{T100}$	13	R_0	2	4	8	$\text{k}\Omega$
Saturation voltage	$V_{6-8} \geq V_{T100}$, $I_{13} = 10\text{ }\mu\text{A}$	13	V_{13-8}		100		mV

7. Diagrams

Figure 7-1. Ramp Control

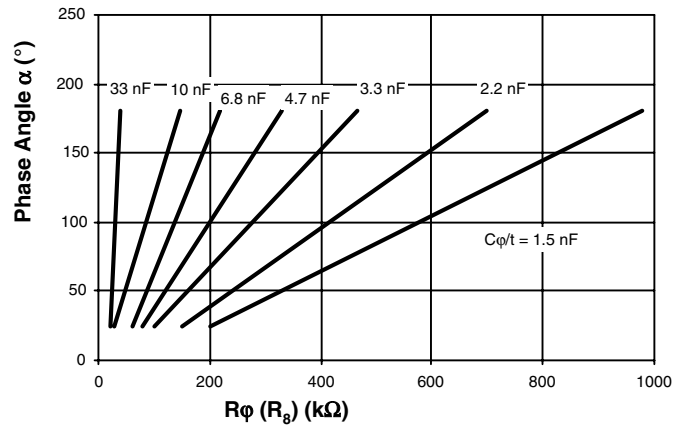

Figure 7-2. Pulse Output

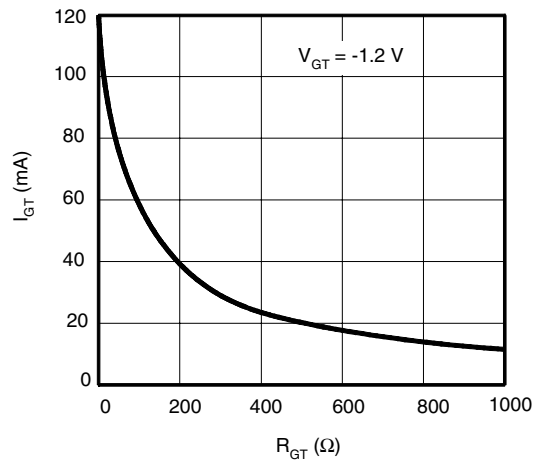

Figure 7-3. Output Pulse Width

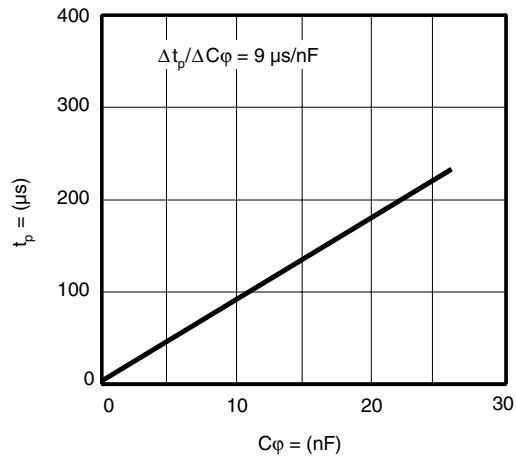

Figure 7-4. Soft-start Charge Current

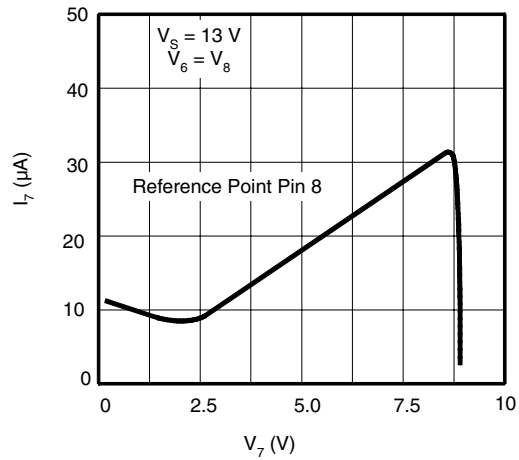

Figure 7-5. Soft-start Characteristic

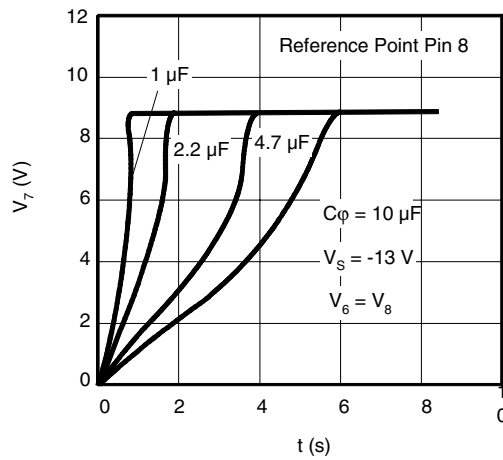

Figure 7-6. Mains Voltage Compensation

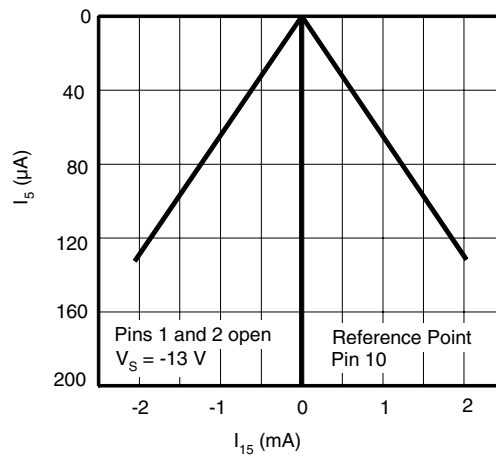

Figure 7-7. Load-current Detection

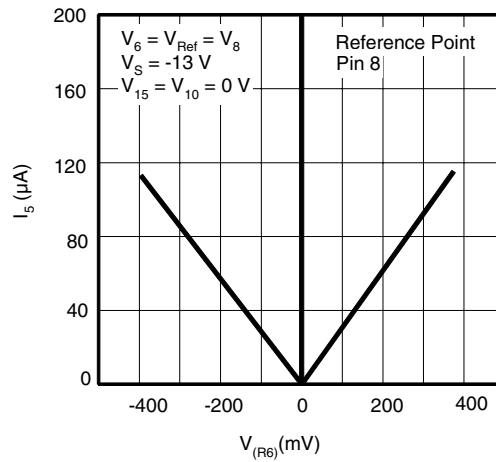

Figure 7-8. Restart Switching Auto Start Mode

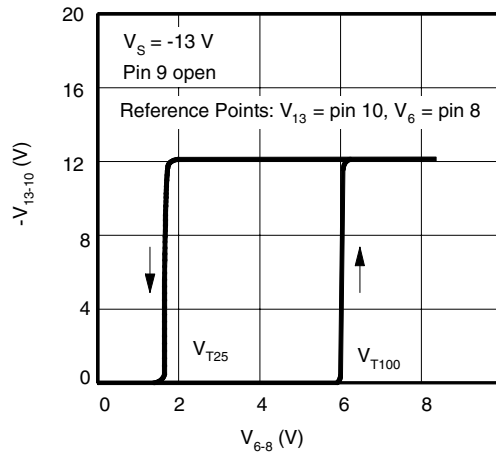

Figure 7-9. High Load Switching (70%)

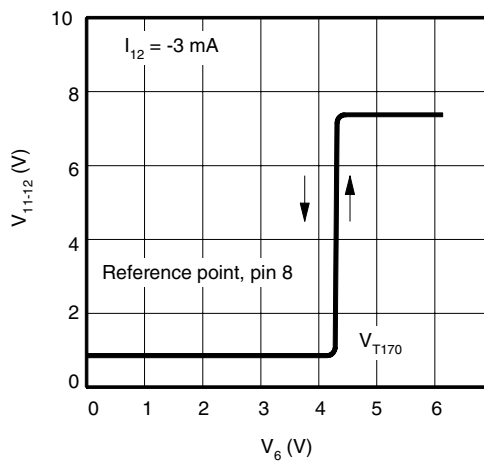

Figure 7-10. Overload Switching

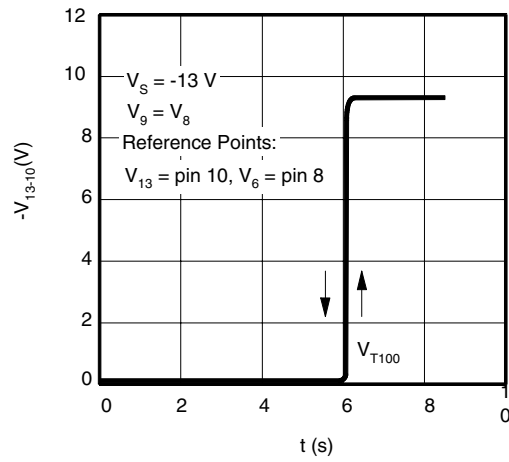

Figure 7-11. Load Limitation

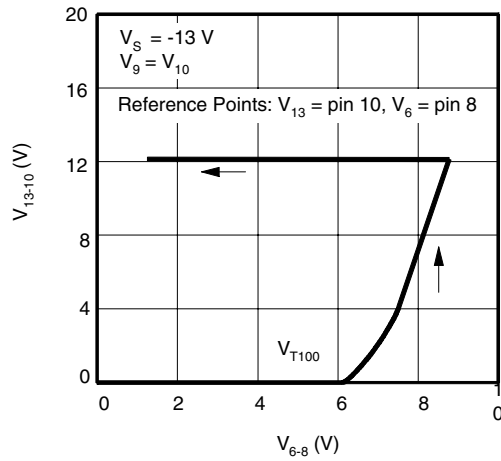

Figure 7-12. Power Dissipation of R_1

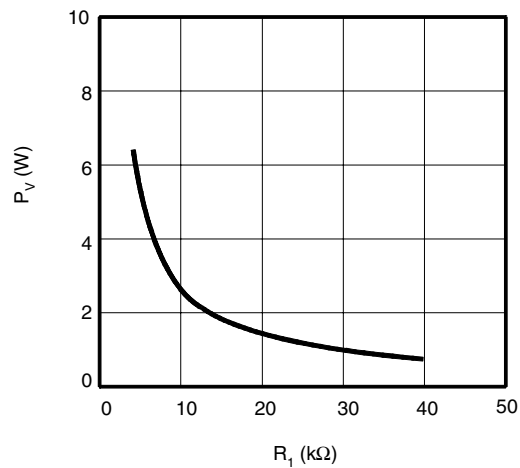

Figure 7-13. Power Dissipation of R_1 According to Current Consumption

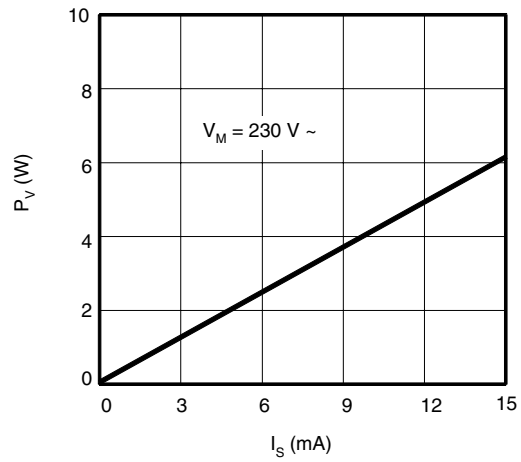

Figure 7-14. Maximum Resistance of R_1

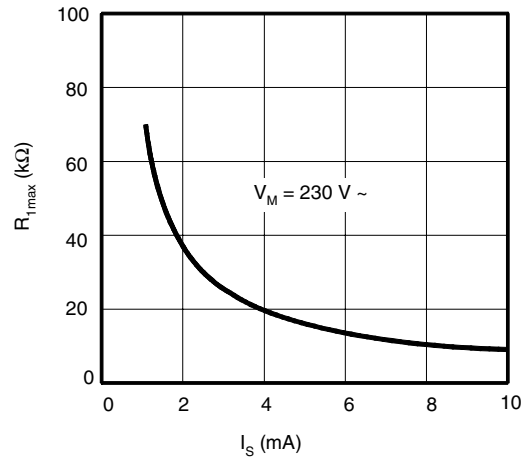
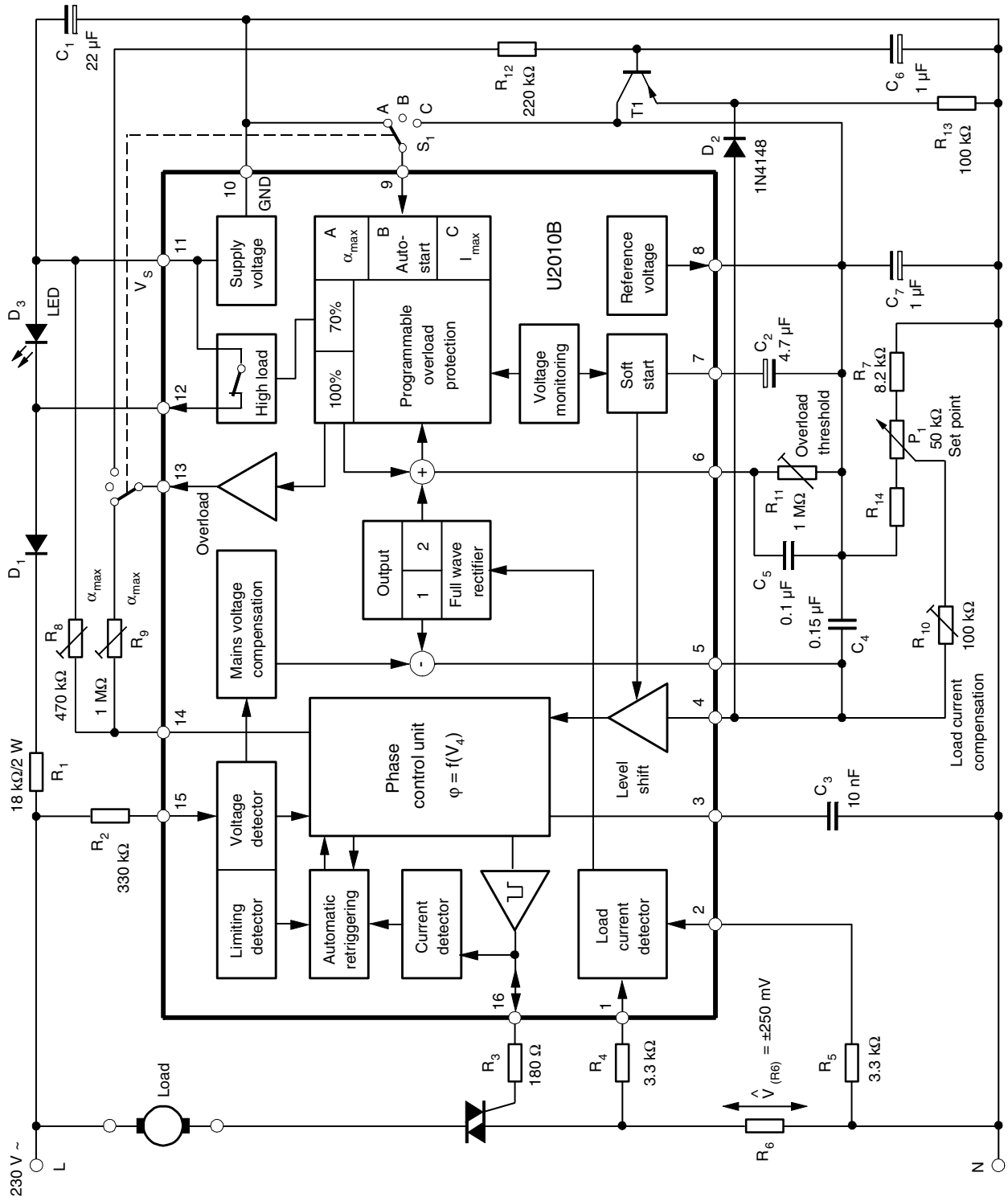

Figure 7-15. Application Circuit



8. Ordering Information

Extended Type Number	Package	Remarks
U2010B-xY	DIP16	Tube, Pb-free
U2010B-xFPY	SO16	Tube, Pb-free
U2010B-xFPG3Y	SO16	Taped and reeled, Pb-free

9. Package Information

Package DIP16
Dimensions in mm

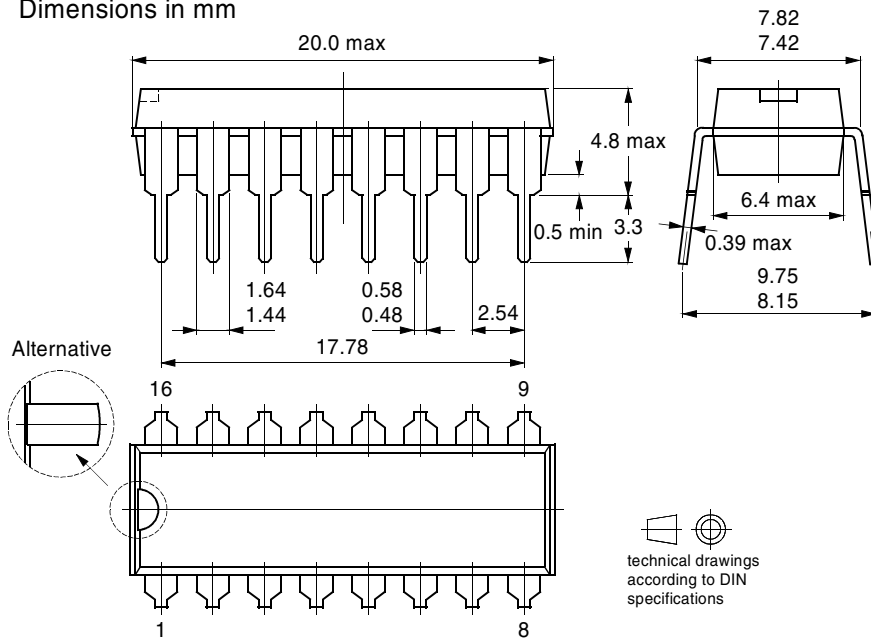

Package SO16
Dimensions in mm

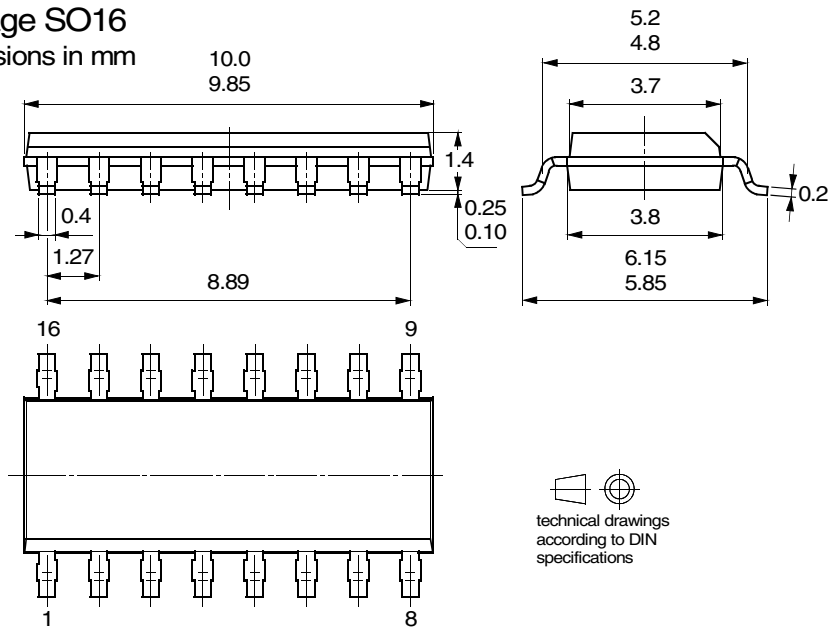

10. Revision History

Please note that the following page numbers referred to in this section refer to the specific revision mentioned, not to this document.

Revision No.	History
4766B-INDCO-08/05	<ul style="list-style-type: none"> • Put datasheet in a new template • First page: Pb-free logo added • Page 16: Ordering Information changed



Atmel Corporation

2325 Orchard Parkway
San Jose, CA 95131, USA
Tel: 1(408) 441-0311
Fax: 1(408) 487-2600

Regional Headquarters

Europe

Atmel Sarl
Route des Arsenaux 41
Case Postale 80
CH-1705 Fribourg
Switzerland
Tel: (41) 26-426-5555
Fax: (41) 26-426-5500

Asia

Room 1219
Chinachem Golden Plaza
77 Mody Road Tsimshatsui
East Kowloon
Hong Kong
Tel: (852) 2721-9778
Fax: (852) 2722-1369

Japan

9F, Tonetsu Shinkawa Bldg.
1-24-8 Shinkawa
Chuo-ku, Tokyo 104-0033
Japan
Tel: (81) 3-3523-3551
Fax: (81) 3-3523-7581

Atmel Operations

Memory

2325 Orchard Parkway
San Jose, CA 95131, USA
Tel: 1(408) 441-0311
Fax: 1(408) 436-4314

Microcontrollers

2325 Orchard Parkway
San Jose, CA 95131, USA
Tel: 1(408) 441-0311
Fax: 1(408) 436-4314

La Chantrerie
BP 70602
44306 Nantes Cedex 3, France
Tel: (33) 2-40-18-18-18
Fax: (33) 2-40-18-19-60

ASIC/ASSP/Smart Cards

Zone Industrielle
13106 Rousset Cedex, France
Tel: (33) 4-42-53-60-00
Fax: (33) 4-42-53-60-01

1150 East Cheyenne Mtn. Blvd.
Colorado Springs, CO 80906, USA
Tel: 1(719) 576-3300
Fax: 1(719) 540-1759

Scottish Enterprise Technology Park
Maxwell Building
East Kilbride G75 0QR, Scotland
Tel: (44) 1355-803-000
Fax: (44) 1355-242-743

RF/Automotive

Theresienstrasse 2
Postfach 3535
74025 Heilbronn, Germany
Tel: (49) 71-31-67-0
Fax: (49) 71-31-67-2340

1150 East Cheyenne Mtn. Blvd.
Colorado Springs, CO 80906, USA
Tel: 1(719) 576-3300
Fax: 1(719) 540-1759

Biometrics/Imaging/Hi-Rel MPU/ High Speed Converters/RF Datacom

Avenue de Rochepleine
BP 123
38521 Saint-Egreve Cedex, France
Tel: (33) 4-76-58-30-00
Fax: (33) 4-76-58-34-80

Literature Requests

www.atmel.com/literature

Disclaimer: The information in this document is provided in connection with Atmel products. No license, express or implied, by estoppel or otherwise, to any intellectual property right is granted by this document or in connection with the sale of Atmel products. **EXCEPT AS SET FORTH IN ATMEL'S TERMS AND CONDITIONS OF SALE LOCATED ON ATMEL'S WEB SITE, ATMEL ASSUMES NO LIABILITY WHATSOEVER AND DISCLAIMS ANY EXPRESS, IMPLIED OR STATUTORY WARRANTY RELATING TO ITS PRODUCTS INCLUDING, BUT NOT LIMITED TO, THE IMPLIED WARRANTY OF MERCHANTABILITY, FITNESS FOR A PARTICULAR PURPOSE, OR NON-INFRINGEMENT. IN NO EVENT SHALL ATMEL BE LIABLE FOR ANY DIRECT, INDIRECT, CONSEQUENTIAL, PUNITIVE, SPECIAL OR INCIDENTAL DAMAGES (INCLUDING, WITHOUT LIMITATION, DAMAGES FOR LOSS OF PROFITS, BUSINESS INTERRUPTION, OR LOSS OF INFORMATION) ARISING OUT OF THE USE OR INABILITY TO USE THIS DOCUMENT, EVEN IF ATMEL HAS BEEN ADVISED OF THE POSSIBILITY OF SUCH DAMAGES.** Atmel makes no representations or warranties with respect to the accuracy or completeness of the contents of this document and reserves the right to make changes to specifications and product descriptions at any time without notice. Atmel does not make any commitment to update the information contained herein. Unless specifically provided otherwise, Atmel products are not suitable for, and shall not be used in, automotive applications. Atmel's products are not intended, authorized, or warranted for use as components in applications intended to support or sustain life.

© Atmel Corporation 2005. All rights reserved. Atmel®, logo and combinations thereof, Everywhere You Are® and others, are registered trademarks or trademarks of Atmel Corporation or its subsidiaries. Other terms and product names may be trademarks of others.



Printed on recycled paper.

4766B-INDCO-10/05