

Read / Write Base Station IC

Description

IC for IDIC[®] *) read-write base stations

The U2270B is a bipolar integrated circuit for read-write base stations in contactless identification and immobilizer systems.

The IC incorporates the energy transfer circuit to supply the transponder. It consists of an on-chip power supply, an oscillator, and a coil driver optimized for automotive-

specific distances. It also includes all signal-processing circuits which are necessary to form the small input signal into a microcontroller-compatible signal.

The U2270B is well suitable to perform read operations with e5530-GT and TK5530-PP transponders and also performs read-write operations with TK5550-PP and TK5560-PP transponders.

Features

- Carrier frequency f_{osc} 100 KHz – 150 KHz
- Typical data rate up to 5 Kbaud at 125 KHz
- Suitable for Manchester and Bi-phase modulation
- Power supply from the car battery or from 5-V regulated voltage
- Optimized for car immobilizer applications
- Tuning capability
- Microcontroller-compatible interface
- Low power consumption in standby mode
- Power supply output for microcontroller

Applications

- Car immobilizers
- Animal identification
- Access control
- Process control
- Further industrial applications

Case: SO16 U2270B-FP

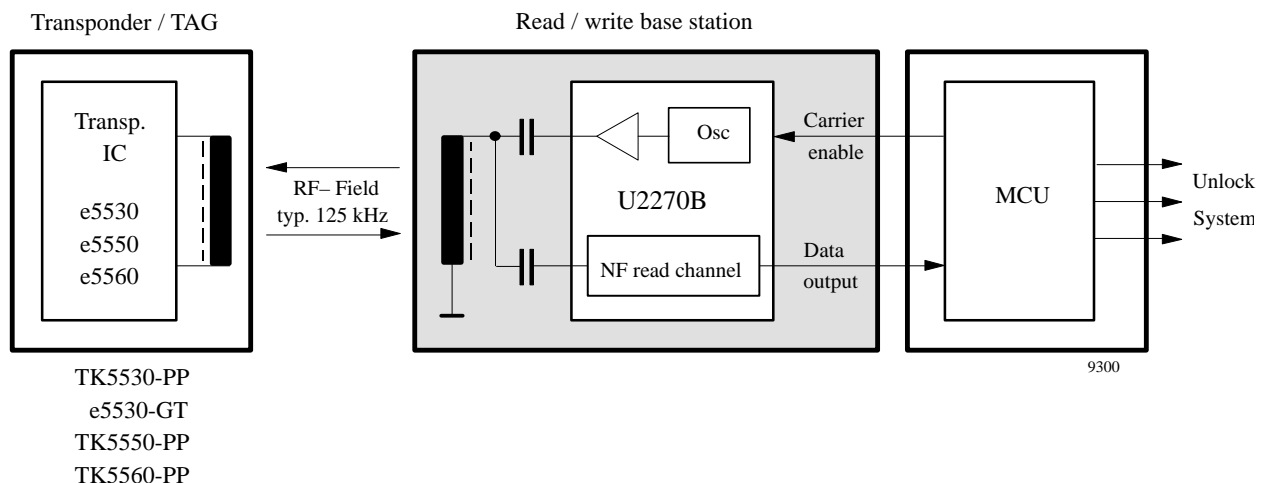
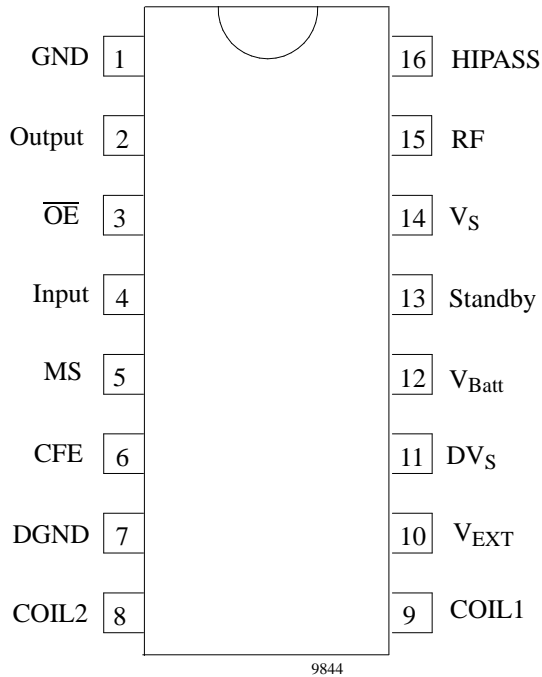

Figure 1.

*) IDIC[®] stands for **ID**entification **I**ntegrated **C**ircuit and is a trademark of TEMIC.

Pin Description



Pin	Symbol	Function
1	GND	Ground
2	Output	Data output
3	\overline{OE}	Data output enable
4	Input	Data input
5	MS	Mode select coil 1: Common mode / Differential mode
6	CFE	Carrier frequency enable
7	DGND	Driver ground
8	COIL 2	Coil driver 2
9	COIL 1	Coil driver 1
10	V_{EXT}	External power supply
11	DV_S	Driver supply voltage
12	V_{Batt}	Battery voltage
13	Standby	Standby input
14	V_S	Internal power supply (5 V)
15	RF	Frequency adjustment
16	HIPASS	DC decoupling

Figure 2. Pinning

Block Diagram

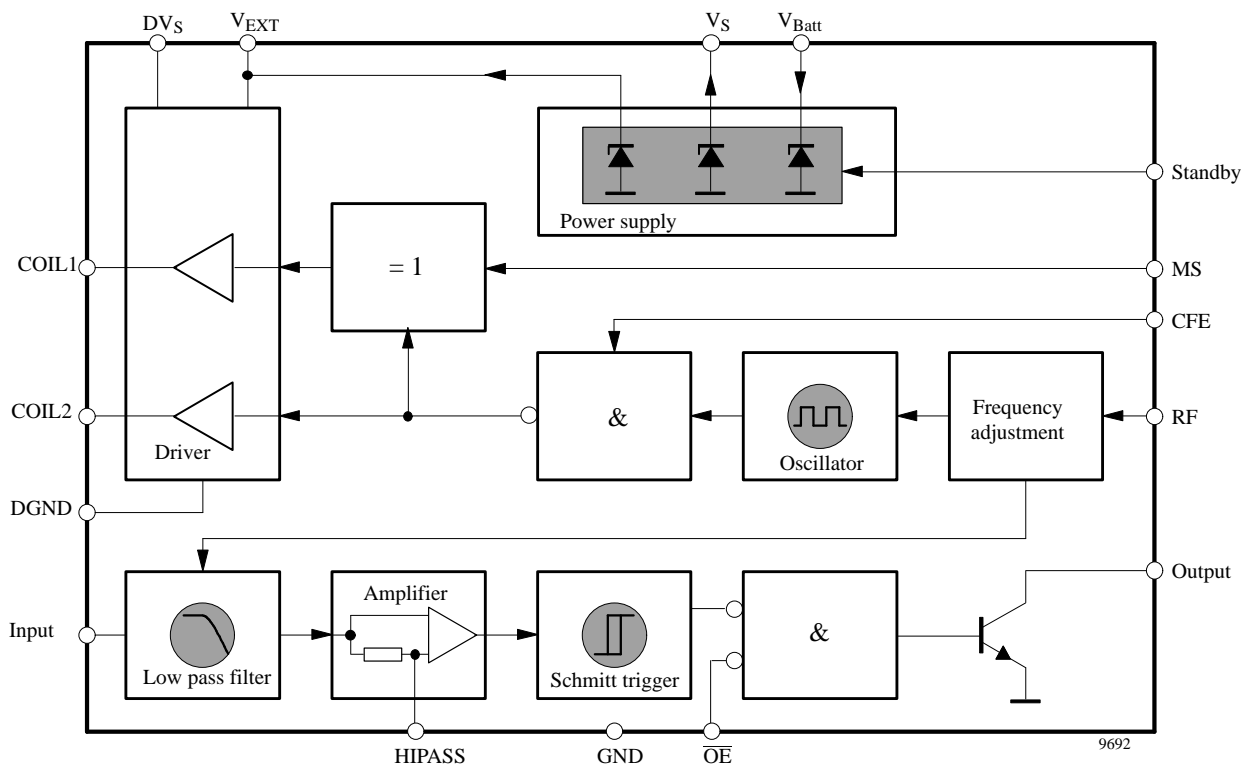

Figure 3.

Functional Description

Power Supply (PS)

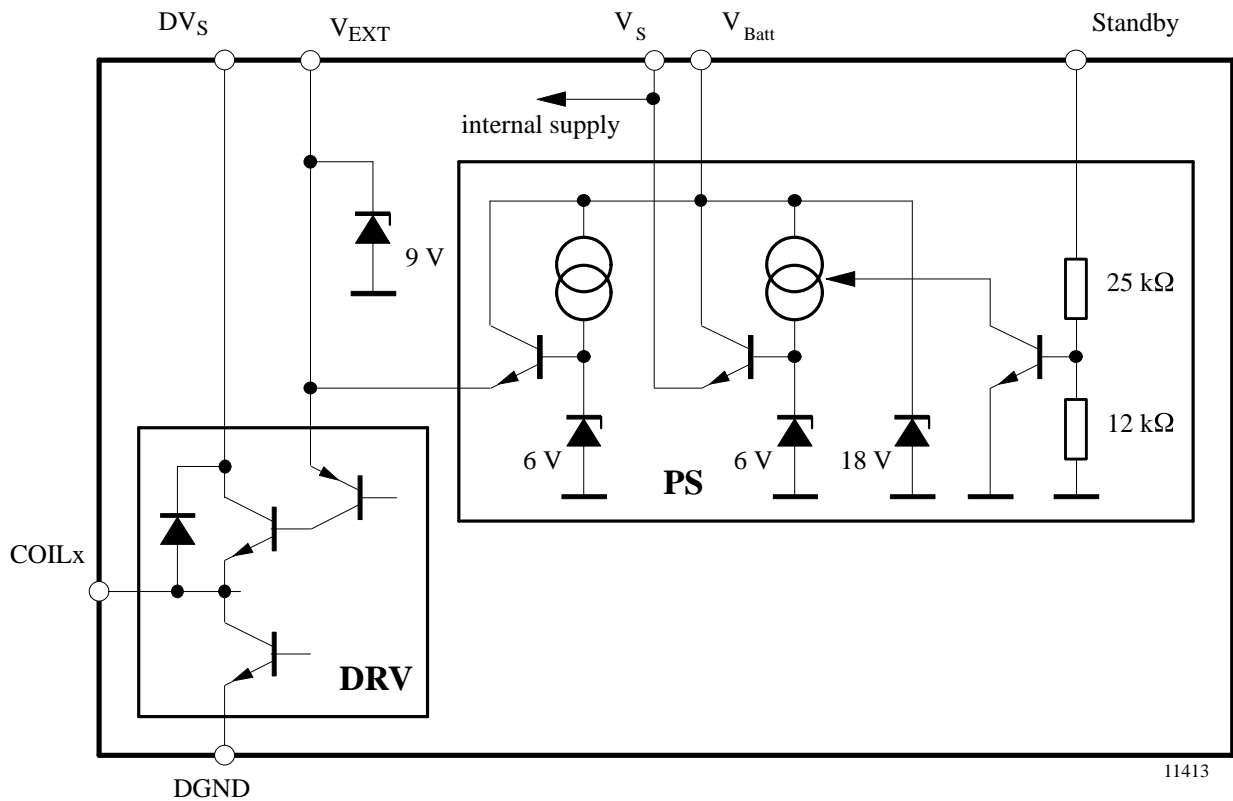

Figure 4. Equivalent circuit of power supply and antenna driver

The U2270 can be operated with one external supply voltage or with two externally-stabilized supply voltages for an extended driver output voltage or from the 12-V battery voltage of a vehicle. The 12-V supply capability is achieved via the on-chip power supply (see figure 4). The power supply provides two different output voltages, V_S and V_{EXT} .

V_S is the internal power supply voltage except for the driver circuit. Pin V_S is used to connect a block capacitor. V_S can be switched off by the pin **STANDBY**. In standby mode, the chip's power consumption is very low. V_{EXT} is the supply voltage of the antenna's pre-driver. This voltage can also be used to operate external circuits, i.e., a microcontroller. In conjunction with an external NPN transistor, it also establishes the supply voltage of the antenna coil driver, DVS .

The following section explains the 3 different operation modes to power the U2270B.

1. One-rail operation

All internal circuits are operated from one 5-V power rail. (see figure 5). In this case, V_S , V_{EXT} and DV_S serve as inputs. V_{Batt} is not used but should also be connected to that supply rail.

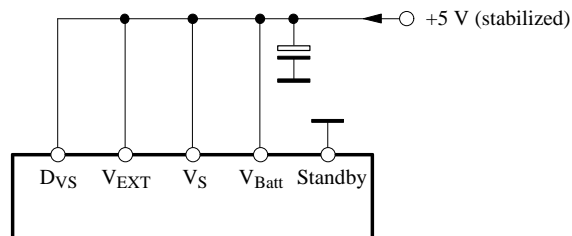

12579

Figure 5.

2. Two-rail operation

In that application, the driver voltage, DV_S , and the pre-driver supply, V_{EXT} , are operated at a higher voltage than the rest of the circuitry to obtain a higher driver-output swing and thus a higher magnetic field, refer to figure 6. V_S is connected to a 5-V supply, whereas the driver voltages can be as high as 8 V. This operation mode is intended to be used in situations where an extended communication distance is required.

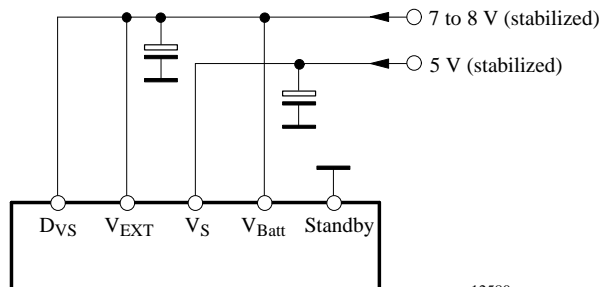

12580

Figure 6.

3. Battery-voltage operation

Using this operation mode, V_S and V_{EXT} are generated by the internal power supply. (refer to figure 7). For this mode, an external voltage regulator is not needed. The IC can be switched off via the pin Standby. V_{EXT} supplies the base of an external NPN transistor and external circuits, i.e., a microcontroller (even in Standby mode).

Pin V_{EXT} and V_{Batt} are overvoltage protected via internal Zener diodes (refer figure 4). The maximum current into that pins is determined by the maximum power dissipation and the maximum junction temperature of the IC. For a short-time current pulse, a higher power dissipation can be assumed (refer to application note ANT019).

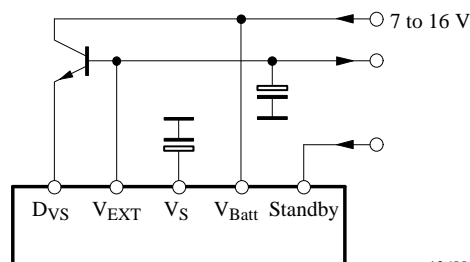

12600

Figure 7.

Table 1. The following table summarizes the characteristics of the various operation modes.

Operation Mode	External Components Required	Supply Voltage Range	Driver Output Voltage Swing	Standby Mode Available
1. One-rail operation	1 Voltage regulator 1 Capacitor	5 V \pm 10%	\approx 4 V	No
2. Two-rail operation	2 Voltage regulators 2 Capacitors	5 V \pm 10% 7 V to 8 V	6 V to 7 V	No
3. Battery voltage operation	1 Transistor 2 Capacitors Optional for load-dump protection: 1 Resistor 1 Capacitor	6 V to 16 V	\approx 4 V	Yes

Oscillator (Osc)

The frequency of the on-chip oscillator is controlled by a current fed into the R_F input. An integrated compensation circuit ensures a widely temperature and supply voltage independent frequency which is selected by a fixed resistor between R_F (pin 15) and V_S (pin 14). For 125 kHz a resistor value of 110 k Ω is defined. For other frequencies, use the following formula:

$$R_f = \frac{14375}{f_0 [\text{kHz}]} - 5 \text{ k}\Omega$$

This input can be used to adjust the frequency close to the resonance of the antenna. For more details refer to the applications and the application note ANT019.

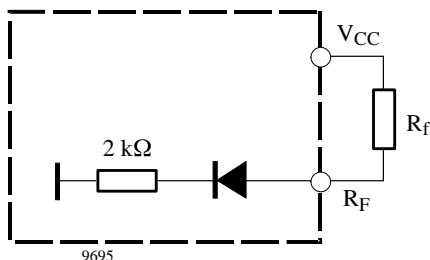

Figure 8. Equivalent circuit of Pin R_F

Filter (LPF)

The fully-integrated low-pass filter (4th order butterworth) removes the remaining carrier signal and high-frequency disturbances after demodulation. The upper cut-off frequency of the LPF depends on the selected oscillator frequency. The typ. value is $f_{osc}/18$. That means that data rates up to $f_{osc}/25$ are possible if Bi-phase or Manchester encoding is used.

A high-pass characteristic results from the capacitive coupling at the input Pin 4, as shown in figure 9. The input voltage swing is limited to 2 V_{pp} . For frequency response calculation, the impedances of the signal source and LPF input (typ. 220 k Ω) have to be considered. The recommended values of the input capacitor for selected data rates are shown in the chapter "Applications".

Note: After switching on the carrier, the dc voltage of the coupling capacitor changes rapidly. When the antenna voltage is stable, the LPF needs approximately 2 ms to recover full sensitivity.

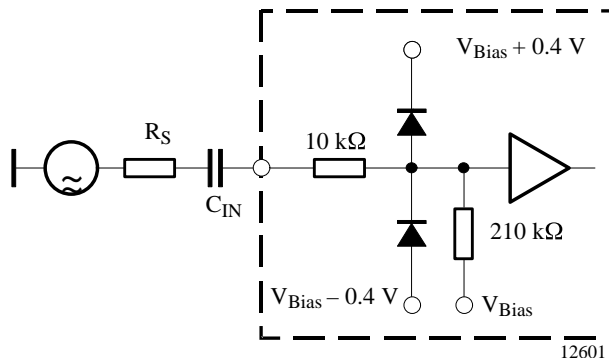

Figure 9. Equivalent circuit of Pin Input

Amplifier (AMP)

The differential amplifier has a fixed gain, typically 30. The HIPASS pin is used for dc decoupling. The lower cut-off frequency of the decoupling circuit can be calculated as follows:

$$f_{cut} = \frac{1}{2 \times \pi \times C_{HP} \times R_i}$$

The value of the internal resistor R_i can be assumed to be 2.5 k Ω .

Recommended values of C_{HP} for selected data rates can be found in the chapter "Applications".

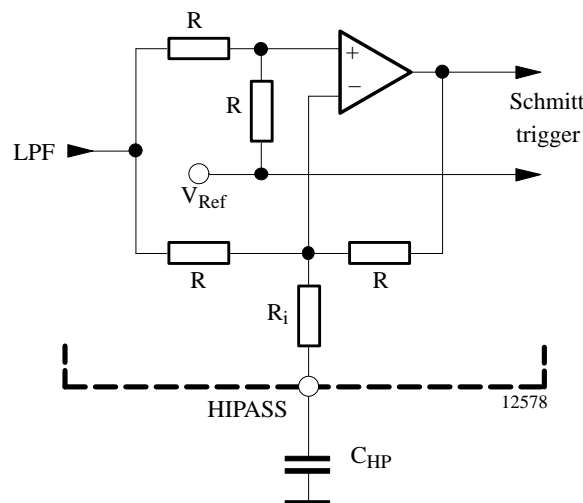

Figure 10. Equivalent circuit of pin HIPASS

Schmitt Trigger

The signal is processed by a Schmitt trigger to suppress possible noise and to make the signal μC compatible. The hysteresis level is 100 mV symmetrically to the dc operation point. The open-collector output is enabled by a low level at $\overline{\text{OE}}$ (Pin 3).

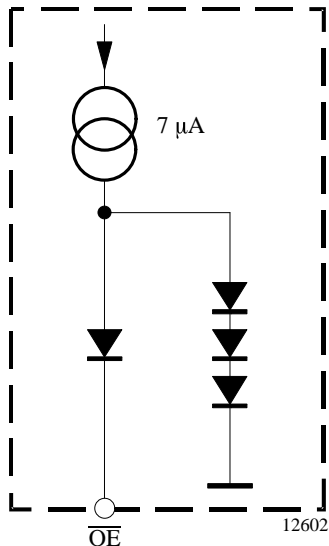

Figure 11. Equivalent circuit of Pin $\overline{\text{OE}}$

Driver (DRV)

The driver supplies the antenna coil with the appropriate energy. The circuit consists of two independent output stages. These output stages can be operated in two different modes. In common mode, the outputs of the stages are in phase. In this mode, the outputs can be interconnected, to achieve a high current output capability. Using the differential mode, the output voltages are in anti-phase. Thus, the antenna coil is driven with a higher voltage. For a specific magnetic field, the antenna coil impedance is higher for the differential mode. As a higher coil impedance results in a better system sensitivity, the differential mode should be preferred.

The CFE input is intended to be used for writing data into a read/write or a crypto transponder. This is achieved by interrupting the RF field with short gaps. The TEMIC write method is described in the data sheets of TK5550 and TK5560. The various functions are controlled by the inputs MS and CFE, refer to function table. The equivalent circuit of the driver is shown in figure 4.

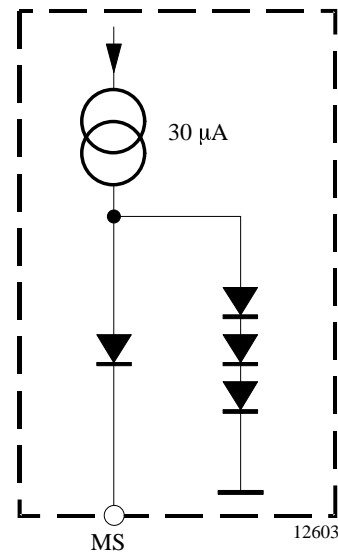

Figure 12. Equivalent circuit of Pin MS

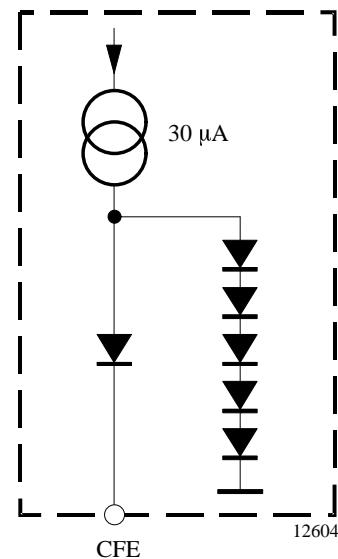





Figure 13. Equivalent circuit of Pin CFE

Function Table

CFE	MS	COIL1	COIL2
Low	Low	High	High
Low	High	Low	High
High	Low		
High	High		

OE	Output
Low	Enabled
High	Disabled

Standby	U2270B
Low	Standby mode
High	Active

Applications

To achieve the suitable application, consider the power supply environment and the magnetic coupling situation.

The selection of the appropriate power supply operation mode depends on the supply environment. If an unregulated supply voltage in the range of $V = 7\text{ V}$ to 16 V is available, the internal power supply of the U2270B can be used. In this case, the standby mode can be used and an external low-current μC can be supplied.

If a 5-V supply rail is available, it can be used to power the U2270B. In this case please check that the voltage is noise-free. An external power transistor is not necessary.

The application depends also on the magnetic coupling situation. The coupling factor mainly depends on the transmission distance and the antenna coils. The following table lists the appropriate application for a given coupling factor. The magnetic coupling factor can be determined using the TEMIC test transponder coil.

Magnetic Coupling Factor	Appropriate Application
$k > 3\%$	Free-running oscillator
$k > 1\%$	Diode feedback
$k > 0.5\%$	Diode feedback plus frequency altering
$k > 0.3\%$	Diode feedback plus fine frequency tuning

The maximum transmission distance is also influenced by the accuracy of the antenna's resonance. Therefore, the recommendations given above are proposals only. A good compromise for the resonance accuracy of the antenna is a value in the range of $f_{\text{res}} = 125\text{ kHz} \pm 3\%$. Further details concerning the adequate application and the antenna design is provided in the TEMIC application note ANT019 and in the TEMIC article "Antenna Design Hints".

The application of the U2270B includes the two capacitors C_{IN} and C_{HP} whose values are linearly dependent on the transponder's data rate. The following table gives the appropriate values for the most common data rates. The values are valid for Manchester and Bi-phase code.

Data Rate	Input Capacitor (C_{IN})	Decoupling Capacitor (C_{HP})
$f = 125\text{ kHz}$		
$f/32 = 3.9\text{ kbit/s}$	680 pF	100 nF
$f/64 = 1.95\text{ kbit/s}$	1.2 nF	220 nF

The following applications are typical examples. The values of C_{IN} and C_{HP} correspond to the transponder's data rate only. The arrangement to fit the magnetic coupling situation is also independent from other design issues except of one constellation. This constellation, consisting of diode feedback plus fine frequency tuning together with the two-rail power supply should be used if the transmission distance is in the range of $d \approx 10\text{ cm}$.

Application 1

Application using few external components. This application is for intense magnetic coupling only.

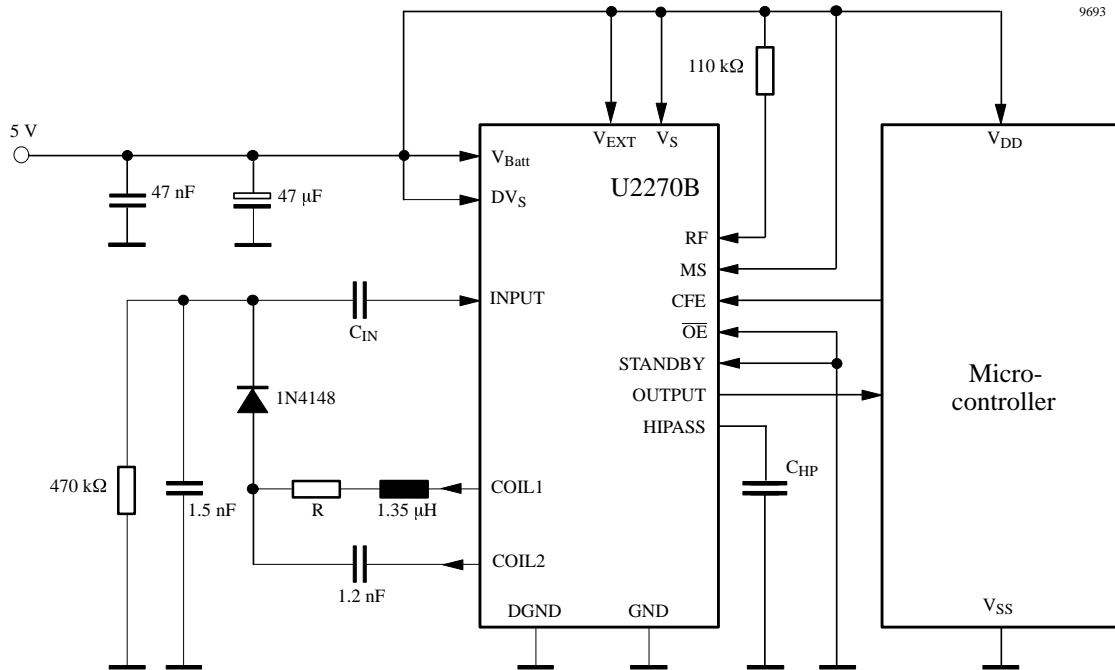

Figure 14.

Application 2

Basic application using diode feedback. This application permits higher communication distances than application 1.

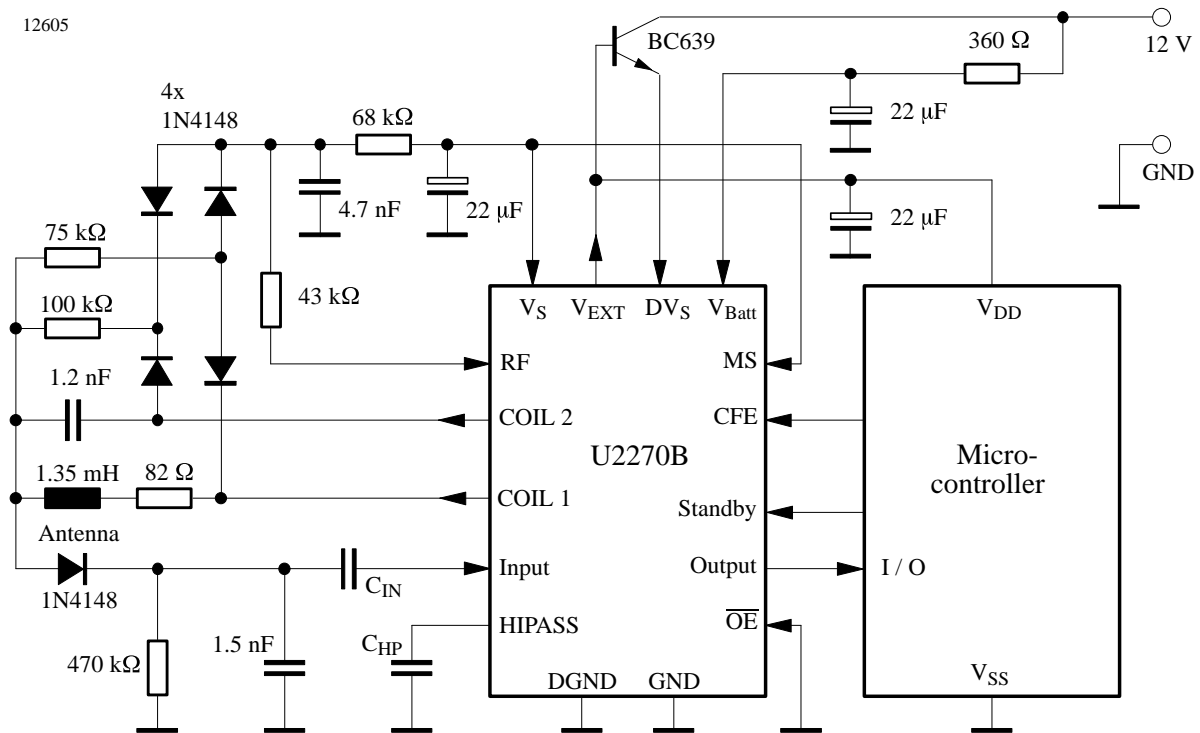

Figure 15.

Application 3

This application is comparable to application 2 but alters the operating frequency. This permits higher antenna resonance tolerances and/or higher communication

distances. This application is preferred if the detecting μC is close to the U2270B as an additional μC signal controls the adequate operating frequency.

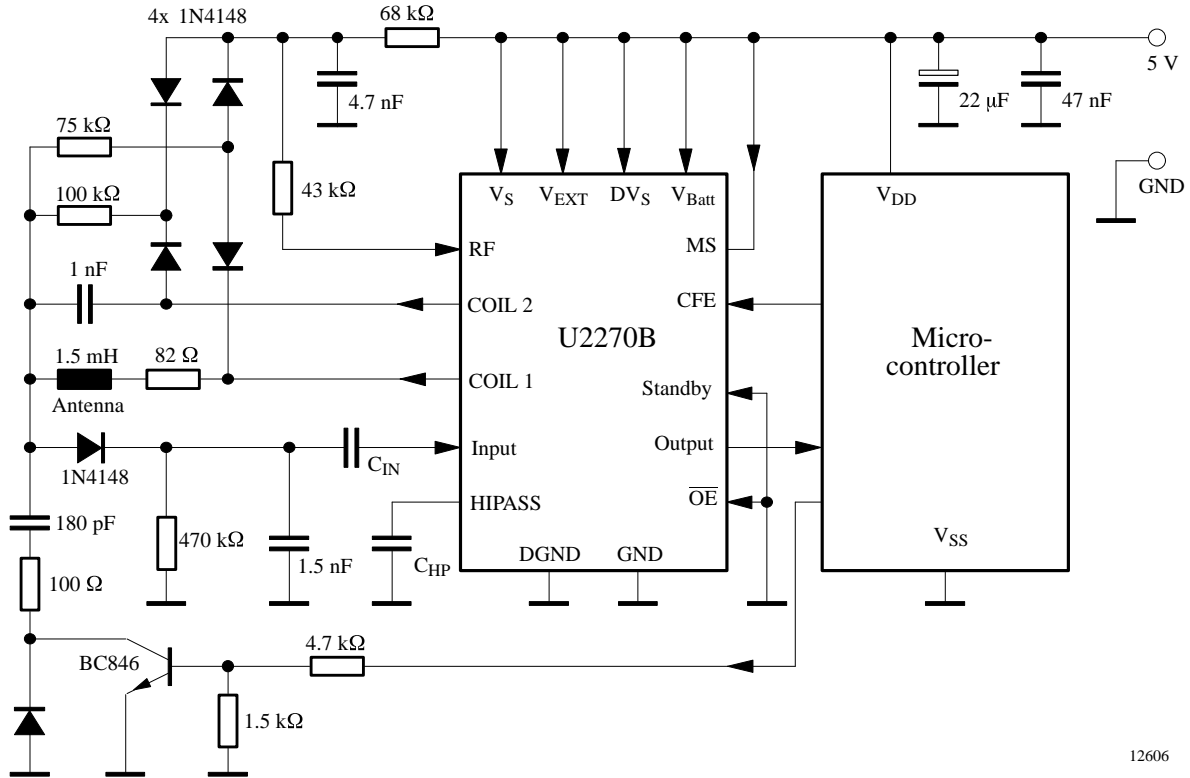

Figure 16.

12606

Absolute Maximum Ratings

All voltages are referred to GND (Pins 1 and 7).

Parameters/Conditions Pin	Symbol	Min.	Typ.	Max.	Unit
Operating voltage Pin 12	V_{Batt}	V_S		16	V
Operating voltage Pins 8, 9, 10, 11 and 14	$V_S, V_{EXT}, DV_S, \text{Coil 1, Coil 2}$	-0.3		8	V
Range of input and output voltages Pins 3, 4, 5, 6, 15 and 16 Pins 2 and 13		-0.3 -0.3		$V_S+0.3$ V_{Batt}	V
Output current Pin 10	I_{EXT}			10	mA
Output current Pin 2	I_{OUT}			10	mA
Driver output current Pins 8 and 9	I_{Coil}			200	mA
Power dissipation SO16	P_{tot}			380	mW
Junction temperature	T_j			150	°C
Storage temperature	T_{stg}	-55		125	°C
Ambient temperature	T_{amb}	-40		105	°C

Thermal Resistance

Parameters/Conditions Pin	Symbol	Min.	Typ.	Max.	Unit
Thermal resistance SO16	R_{thJA}			120	K/W

Operating Range

All voltages are referred to GND (Pins 1 and 7)

Parameters/Conditions Pin	Symbol	Min.	Typ.	Max.	Unit
Operating voltage Pin 12	V_{Batt}	7	12	16	V
Operating voltage Pin 14	V_S	4.5	5.4	6.3	V
Operating voltage Pin 10 Pin 11	V_{EXT} DV_S	4.5		8	
Carrier frequency	f_{osc}	100	125	150	kHz

Electrical Characteristics

Test conditions (unless otherwise specified): $V_{Batt} = 12\text{ V}$, $T_{amb} = -40\text{ to }105^\circ\text{C}$

Parameters	Test Conditions / Pins	Symbol	Min.	Typ.	Max.	Unit
Data output – collector emitter saturation voltage	Pin 2 $I_{out} = 5\text{ mA}$	V_{CEsat}			400	mV
Data output enable – low level input voltage – high level input voltage	Pin 3	V_{il} V_{ih}	2.4		0.5	V V
Data input – clamping level low – clamping level high – input resistance – input sensitivity	Pin 4 $f = 3\text{ kHz}$ (squarewave) gain capacitor = 100 nF	V_{il} V_{ih} R_{in}	10	2 3.8 220		V V k Ω mV pp
Driver polarity mode – low level input voltage – high level input voltage	Pin 5	V_{il} V_{ih}	2.4		0.2	V V
Carrier frequency enable – low level input voltage – high level input voltage	Pin 6	V_{il} V_{ih}	3.0		0.8	V V
Operating current	Pin10, 11, 12 and 14 5 V application without load connected to the coil driver	I_S		4.5	9	mA
Standby current	Pin 12 12 V application	I_{St}		30	70	μA
V_S – Supply voltage – Supply voltage drift – Output current	Pin 14	V_S dV_S/dT I_S	4.6 1.8	5.4 4.2 3.5	6.3	V mV/K mA
Driver output voltage – One rail operation – Battery voltage operation	$I_L = \pm 100\text{ mA}$ $V_S, V_{EXT}, V_{Batt}, DV_S = 5\text{ V}$ $V_{Batt} = 12\text{ V}$ Pins 8 and 9	V_{DRV} V_{DRV}	2.9 3.1	3.6 4.0	4.3 4.7	V_{PP} V_{PP}
V_{ext} – Output voltage – Supply voltage drift – Output current – Standby output current	Pin 10 IC active standby mode	V_{EXT} dV_{EXT}/dT I_{EXT} I_{EXT}	4.6 3.5 0.4	5.4 4.2	6.3	V mV/K mA mA
Standby input – low level input voltage – high level input voltage	Pin 13	V_{il} V_{ih}	3.1		0.8	V V
Oscillator – Carrier frequency	RF-resistor = 110 k Ω (application 2), REM 1.	f_0	121	125	129	kHz
Low pass filter – Cut off frequency	Carrier freq. = 125 kHz	f_{cut}		7		kHz
Amplifier – Gain	$C_{HP} = 100\text{ nF}$			30		
Schmitt trigger – Hysteresis voltage				100		mV

REM 1.: In application 1. where the oscillator operates in the free running mode, the IC must be soldered free from distortion. Otherwise, the oscillator frequency may be out of bounds.

Dimensions in mm

Package: SO16

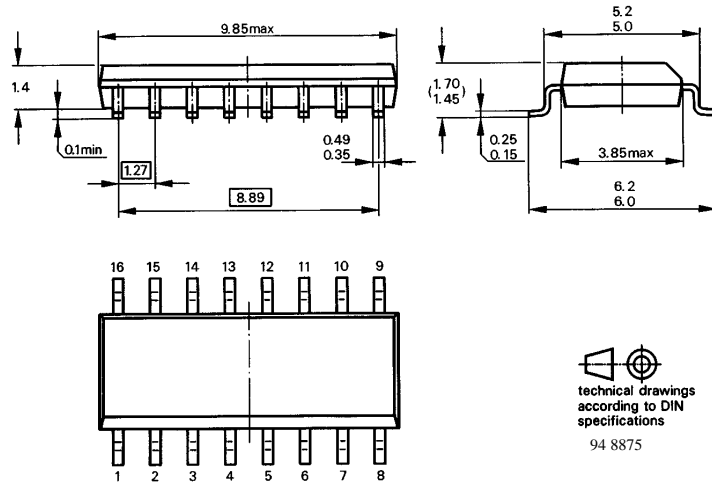

Ozone Depleting Substances Policy Statement

It is the policy of **TEMIC TELEFUNKEN microelectronic GmbH** to

1. Meet all present and future national and international statutory requirements.
2. Regularly and continuously improve the performance of our products, processes, distribution and operating systems with respect to their impact on the health and safety of our employees and the public, as well as their impact on the environment.

It is particular concern to control or eliminate releases of those substances into the atmosphere which are known as ozone depleting substances (ODSs).

The Montreal Protocol (1987) and its London Amendments (1990) intend to severely restrict the use of ODSs and forbid their use within the next ten years. Various national and international initiatives are pressing for an earlier ban on these substances.

TEMIC TELEFUNKEN microelectronic GmbH semiconductor division has been able to use its policy of continuous improvements to eliminate the use of ODSs listed in the following documents.

1. Annex A, B and list of transitional substances of the Montreal Protocol and the London Amendments respectively
2. Class I and II ozone depleting substances in the Clean Air Act Amendments of 1990 by the Environmental Protection Agency (EPA) in the USA
3. Council Decision 88/540/EEC and 91/690/EEC Annex A, B and C (transitional substances) respectively.

TEMIC can certify that our semiconductors are not manufactured with ozone depleting substances and do not contain such substances.

We reserve the right to make changes to improve technical design and may do so without further notice.

Parameters can vary in different applications. All operating parameters must be validated for each customer application by the customer. Should the buyer use TEMIC products for any unintended or unauthorized application, the buyer shall indemnify TEMIC against all claims, costs, damages, and expenses, arising out of, directly or indirectly, any claim of personal damage, injury or death associated with such unintended or unauthorized use.

TEMIC TELEFUNKEN microelectronic GmbH, P.O.B. 3535, D-74025 Heilbronn, Germany
Telephone: 49 (0)7131 67 2831, Fax number: 49 (0)7131 67 2423