

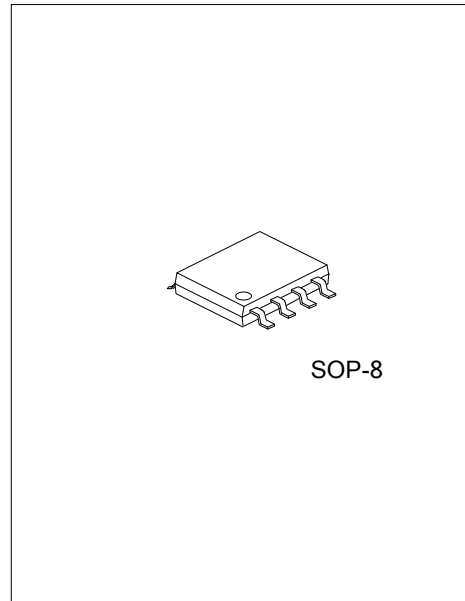

1.2MHZ, 2A SYNCHRONOUS STEP-DOWN CONVERTER

DESCRIPTION

The UTC **UD05201** is a 1.2MHz constant frequency current mode PWM step-down converter. It is ideal for portable equipment requiring very high current up to 2A from single-cell Lithium-ion batteries while still achieving over 90% efficiency during peak load conditions. The UTC **UD05201** also can run at 100% duty cycle for low dropout operation, extending battery life in portable systems while light load operation provides very low output ripple for noise sensitive applications. The UTC **UD05201** can supply up to 2A output load current from a 2.6V to 5.5V input voltage and the output voltage can be regulated as low as 0.6V. The high switching frequency minimizes the size of external components while keeping switching losses low. The internal slope compensation setting allows the device to operate with smaller inductor values to optimize size and provide efficient operation. The UTC **UD05201** is available in adjustable (0.6V to V_{IN}) output voltage.



FEATURES

- * 2.6V~5.5V Input Voltage Range
- * Output Voltages from 0.6V to V_{IN}
- * High Efficiency: Up to 96%
- * 1.2MHz Constant Frequency Operation
- * Up to 2A Output Current
- * No Schottky Diode Required
- * Low $R_{DS(ON)}$ Internal Switches: 0.15 Ω
- * Current Mode Operation for Excellent Line and Load Transient Response
- * Current limit, Enable function
- * Short Circuit Protect (SCP)
- * Build-in Soft Start function
- * $\leq 1\mu A$ Shutdown Current

ORDERING INFORMATION

Ordering Number	Package	Packing
UD05201G-S08-A-R	SOP-8	Tape Reel
UD05201G-S08-B-R	SOP-8	Tape Reel
UD05201G-S08-C-R	SOP-8	Tape Reel

<p>UD05201G-S08-A-R</p> <ul style="list-style-type: none"> (1)Packing Type (2)Pin Code (3)Package Type (4)Green Package 	<ul style="list-style-type: none"> (1) R: Tape Reel (2) Refer to PIN CONFIGURATION (3) S08: SOP-8 (4) G: Halogen Free and Lead Free
---	---

MARKING

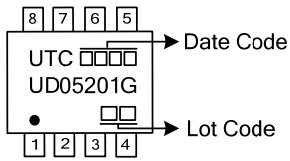

PIN CONFIGURATION

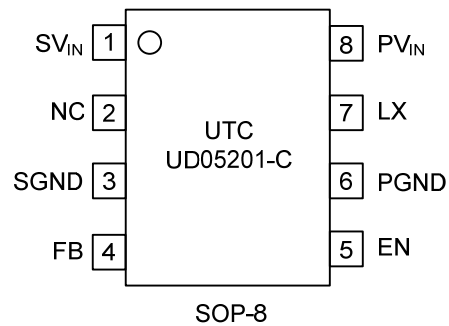
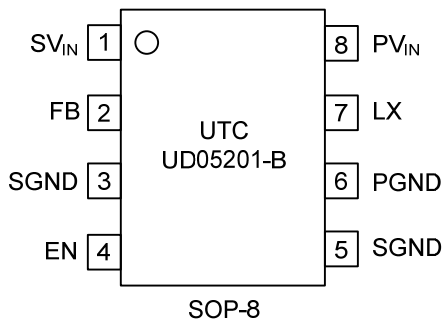
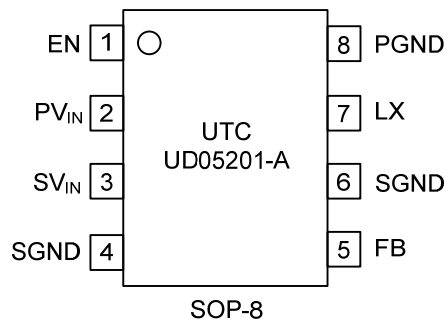

PIN DESCRIPTION

PIN NO.			PIN NAME	DESCRIPTION
A	B	C		
1	4	5	EN	Enable pin H: normal operation L: Shutdown
2	8	8	PV _{IN}	Power Supply Input Pin
3	1	1	SV _{IN}	Signal Supply Input Pin
4, 6	3, 5	3	SGND	Signal Ground Pin
5	2	4	FB	Output Feedback pin
7	7	7	LX	Switch output pin. Connect external inductor here. Minimize trace area at this pin to reduce EMI.
8	6	6	PGND	Power Ground Pin
-	-	2	NC	No connect pin

■ BLOCK DIAGRAM

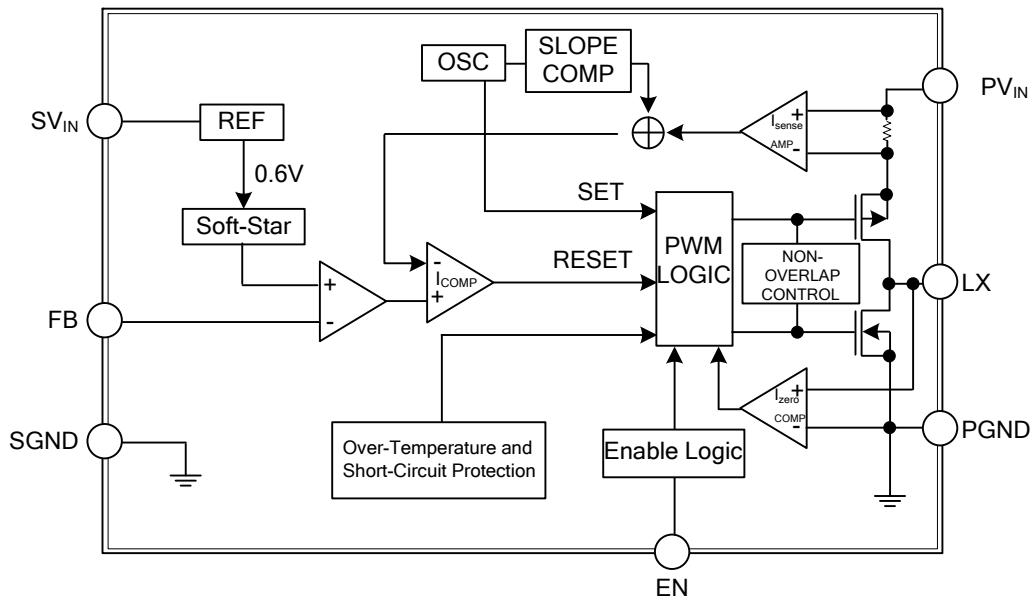

■ ABSOLUTE MAXIMUM RATING ($T_A=25^{\circ}\text{C}$, unless otherwise specified)

PARAMETER	SYMBOL	RATINGS	UNIT
PV _{IN} , SV _{IN} Pin Voltage	V _{IN}	V _{SS} -0.3 to V _{SS} + 6	V
Feedback Pin Voltage	V _{FB}	V _{SS} -0.3 to V _{IN} + 0.3	V
EN Pin Voltage	V _{EN}	V _{SS} -0.3 to V _{IN} + 0.3	V
Switch Pin Voltage	V _{LX}	V _{SS} -0.3 to V _{IN} + 0.3	V
Power Dissipation	P _D		mW
Junction Temperature	T _J	+125	°C
Operating Temperature Range	T _{OPR}	-40~+85	°C
Storage Temperature Range	T _{STG}	-40~+150	°C

Note: Absolute maximum ratings are those values beyond which the device could be permanently damaged. Absolute maximum ratings are stress ratings only and functional device operation is not implied.

■ THERMAL RESISTANCES CHARACTERISTICS

PARAMETER	SYMBOL	RATING	UNIT
Junction to Ambient	θ_{JA}	120	°C/W
Junction to Case	θ_{JC}	40	°C/W

Note: θ_{JA} is measured with the PCB copper area of approximately 1 in²(Multi-layer). That need connect to LX pin or Exposed pad of the UTC **UD05201**.

■ ELECTRICAL CHARACTERISTICS ($V_{IN}=V_{EN}=3.6\text{V}$, $T_A=25^{\circ}\text{C}$, unless otherwise specified)

PARAMETER	SYMBOL	TEST CONDITIONS	MIN	TYP	MAX	UNIT
Supply Voltage Range	V _{IN}		2.6		5.5	V
Feedback Voltage	V _{FB}	T _A =+25°C	0.5880	0.6000	0.6120	V
		T _A =0°C ≤T _A ≤85°C	0.5865	0.6000	0.6135	V
		T _A =-40°C ≤T _A ≤85°C	0.5820	0.6000	0.6180	V
Feedback Bias Current	I _{FB}	V _{FB} =0.65V			±30	nA
Quiescent Current	I _{CCQ}	V _{FB} =0.8V		250	400	uA
Shutdown Supply Current	I _{SD}	V _{EN} =0V		0.1	1	uA
Switching Current Limit	I _{LIMIT}		2.2	2.5		A
Line Regulation	$\Delta V_{OUT} / V_{OUT}$	V _{IN} =2.6V~5.5V		0.04	0.4	%/V
Load Regulation	$\Delta V_{OUT} / V_{OUT}$	I _{OUT} = 0.01~2A		0.5	1	%
Oscillation Frequency	F _{OSC}	LX pin	1	1.2	1.4	MHz
R _{DS(ON)} of P-CH MOSFET	R _{DSON}	V _{FB} =0V, I _{OUT} =1A		0.15	0.25	Ω
R _{DS(ON)} of N-CH MOSFET	R _{DSON}	Guaranteed by design		0.11	0.20	Ω
EN Pin Logic Input Threshold Voltage	V _{ENH}		1.5		0.4	V
EN Pin Input Current	I _{EN}			±0.1	±1	uA
Efficiency	EFFI	V _{IN} =5V, V _{OUT} =3.3V, I _{OUT} =1.5A		91		%
Thermal Shutdown	T _{SD}			140		°C
Thermal Shutdown Hysteresis	T _{SH}			30		°C

■ FUNCTION DESCRIPTIONS

Operation

UTC **UD05201A/B/C** is a monolithic switching mode Step-Down DC-DC converter. It utilizes internal MOSFETs to achieve high efficiency and can generate very low output voltage by using internal reference at 0.6V. It operates at a fixed switching frequency, and uses the slope compensated current mode architecture. This Step-Down DC-DC Converter supplies 2000mA output current at input voltage range from 2.6V to 5.5V.

Current Mode PWM Control

Slope compensated current mode PWM control provides stable switching and cycle-by-cycle current limit for excellent load and line responses and protection of the internal main switch (P-CH MOSFET) and synchronous rectifier (N-CH MOSFET). During normal operation, the internal P-CH MOSFET is turned on for a certain time to ramp the inductor current at each rising edge of the internal oscillator, and switched off when the peak inductor current is above the error voltage. The current comparator, I_{COMP} limits the peak inductor current. When the main switch is off, the synchronous rectifier will be turned on immediately and stay on until either the inductor current starts to reverse, as indicated by the current reversal comparator, I_{ZERO} , or the beginning of the next clock cycle.

■ TYPICAL APPLICATION CIRCUIT

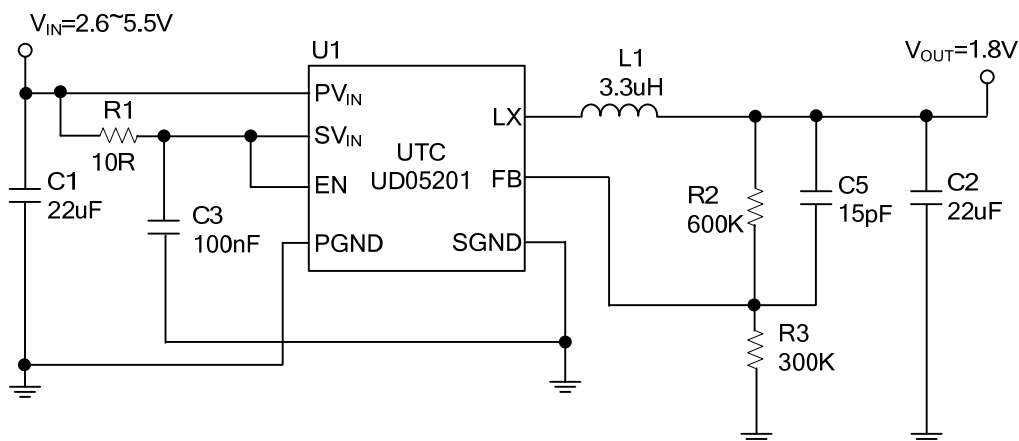

$$V_{OUT} = 0.6 \times (1 + R2/R3)$$

$$R2 = 510K \sim 820K$$

UTC assumes no responsibility for equipment failures that result from using products at values that exceed, even momentarily, rated values (such as maximum ratings, operating condition ranges, or other parameters) listed in products specifications of any and all UTC products described or contained herein. UTC products are not designed for use in life support appliances, devices or systems where malfunction of these products can be reasonably expected to result in personal injury. Reproduction in whole or in part is prohibited without the prior written consent of the copyright owner. The information presented in this document does not form part of any quotation or contract, is believed to be accurate and reliable and may be changed without notice.