



# US3A THRU US3M

## Surface Mount Ultra Fast Rectifiers

### Features

- Low profile package
- Ideal for automated placement
- Glass passivated chip junctions
- Fast switching for high efficiency
- High forward surge capability
- High temperature soldering:  
260°C/10 seconds at terminals
- Component in accordance to  
RoHS 2002/95/1 and WEEE 2002/96/EC



### Mechanical Date

- **Case:** JEDEC DO-214AA molded plastic body over glass passivated chip
- **Terminals:** Solder plated, solderable per J-STD-002B and JESD22-B102D
- **Polarity:** Laser band denotes cathode end

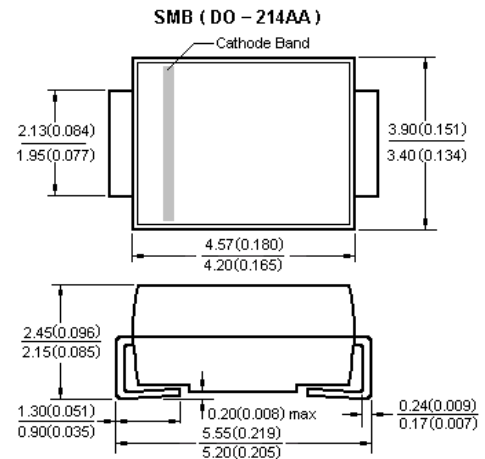

### Maximum Ratings and Electrical Characteristics Rating at 25 °C

ambient temperature unless otherwise specified. Single phase, half wave, 60 Hz, resistive or inductive load. For capacitive load, derate current by 20%

Type Number	SYMBOL	UF3A	UF3B	UF3D	UF3G	UF3J	UF3K	UF3M	Unit
Maximum Recurrent Peak Reverse Voltage	$V_{RRM}$	50	100	200	400	600	800	1000	V
Maximum RMS Voltage	$V_{RMS}$	35	70	140	280	420	560	700	V
Maximum DC Blocking Voltage	$V_{DC}$	50	100	200	400	600	800	1000	V
Average Rectified Output Current @ $T_L = 90^\circ C$	$I_{F(AV)}$	3.0							A
Peak Forward Surge Current 8.3ms Single half sine-wave superimposed on rated load (JEDEC Method)	$I_{FSM}$	80							A
Forward Voltage @ $I_F=3.0A$	$V_{FM}$	1.0		1.3		1.7			V
Peak Reverse Current @ $T_A = 25^\circ C$	$I_R$	3.0							uA
At Rated DC Blocking Voltage @ $T_A = 125^\circ C$		100							
$I^2t$ Rating for Fusing ( $t < 8.3ms$ )	$I^2t$	26.56							A <sup>2</sup> s
Maximum Reverse Recovery Time (Note 1)	$T_{rr}$	50				75			ns
Typical Junction Capacitance (Note 2)	$C_J$	28							pF
Typical Thermal Resistance Junction to Ambient(Note 3)	$R_{\theta JA}$	20							°C/W
Operating Temperature Range	$T_J$	-55 to +150							°C
Storage Temperature Range	$T_{STG}$	-55 to +150							°C

Note: 1.Reverse Recovery Test Conditions: $I_F=0.5A, I_R=1.0A, I_{RR}=0.25A$ .  
2. Measured at 1.0 MHz and Applied reverse Voltage of 4.0V D.C  
3. 8.0MM<sup>2</sup> (.013mm Thick) Land Areas.



# US3A THRU US3M

## Surface Mount Ultra Fast Rectifiers

### Characteristic Curves ( $T_A=25^\circ\text{C}$ unless otherwise noted)

FIG.1 MAXIMUM AVERAGE FORWARD CURRENT DERATING

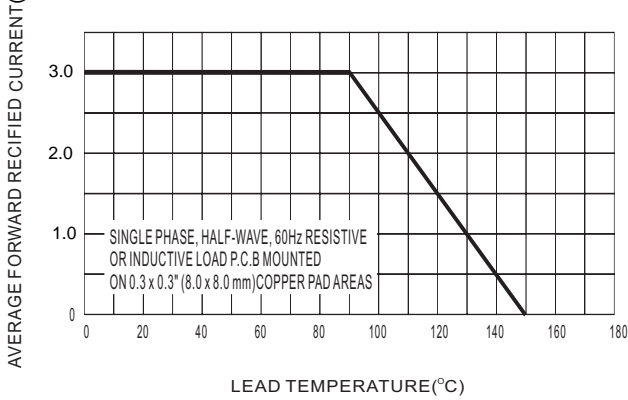

FIG.2 TYPICAL FORWARD CHARACTERISTICS

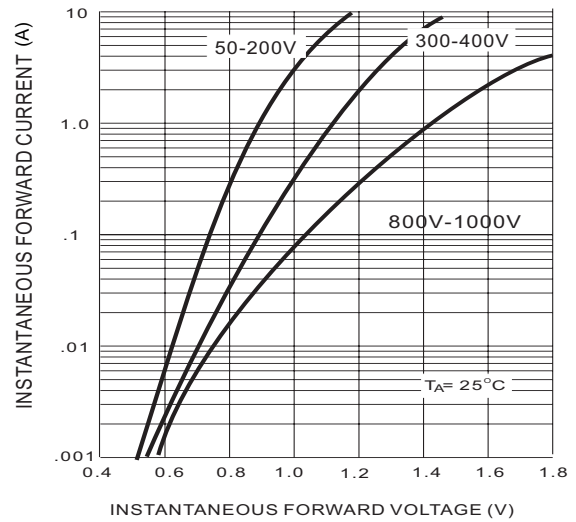

FIG.3 MAXIMUM NON-REPEITIVE SURGE CURRENT

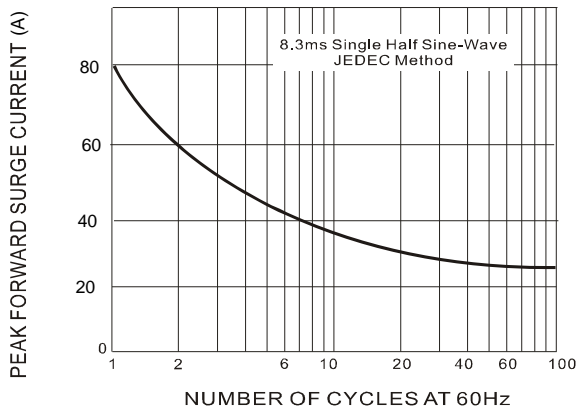

FIG.4 TYPICAL JUNCTION CAPACITANCE

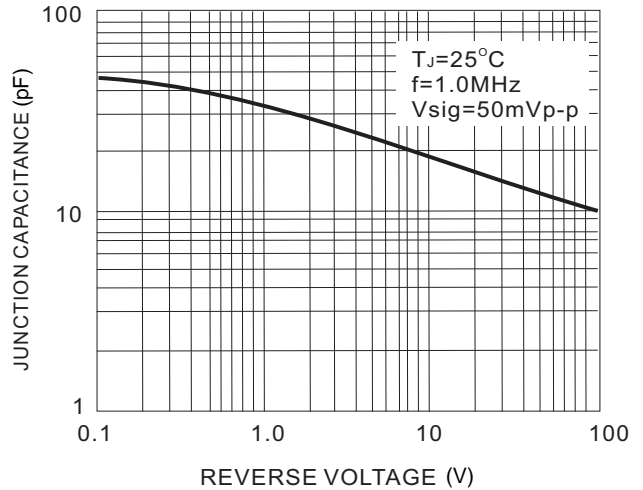

FIG.5 TYPICAL REVERSE CHARACTERISTICS

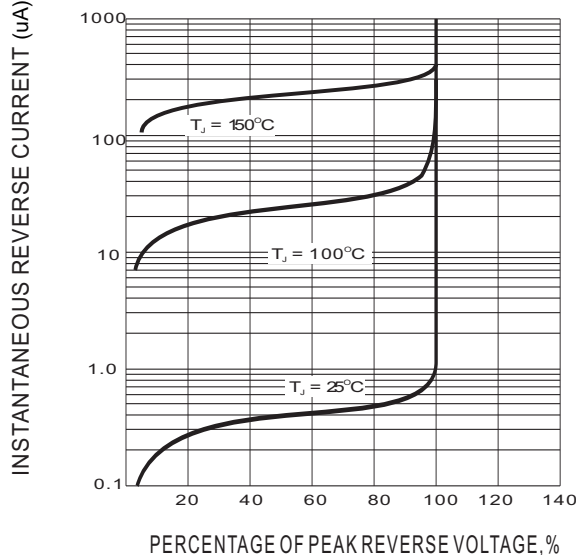

FIG.6 MOUNTING PAD LAYOUT

