

Octal High Voltage,High Current Darlington Transistor Arrays ULN2803APG/AFWG

DESCRIPTIONS:

The eight NPN Darlington connected transistors in this family of arrays are ideally suited for interfacing between low logic level digital circuitry (such as TTL, CMOS or PMOS/NMOS) and the higher current/voltage requirements of lamps, relays, printer hammers or other similar loads for a broad range of computer, industrial, and consumer applications. All devices feature open-collector outputs and free wheeling clamp diodes for transient suppression

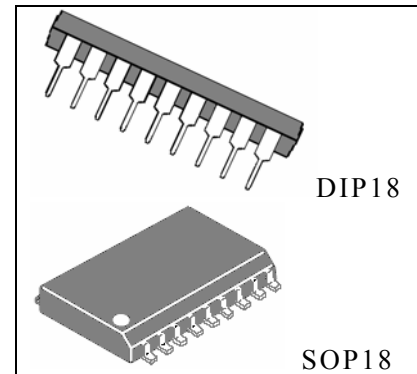

The ULN2803 is designed to be compatible with standard TTL families while the ULN2804 is optimized for 6 to 15 volt high level CMOS or PMOS.

PIN CONNECTION

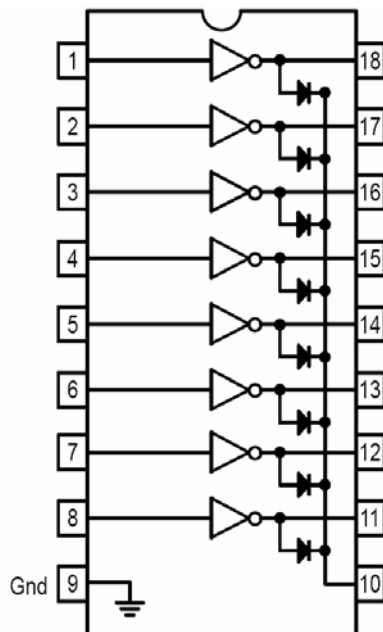

ABSOLUTE MAXIMUM RATINGS ($T_A = 25^\circ\text{C}$ and rating apply to any one device in the package, unless otherwise noted.)

Characteristic	Symbol	Value	Unit
Output voltage	V_O	50	V
Input voltage	V_I	30	V
Collector current- continuous	I_C	500	mA
Base current- continuous	I_B	25	mA
Operating temperature	T_{opr}	0 ~ 70	$^\circ\text{C}$
Storage temperature	T_{stg}	-55 ~ +150	$^\circ\text{C}$
Junction temperature	T_J	125	$^\circ\text{C}$

* $R_{\theta JA} = 55^\circ\text{C/W}$

Do not exceed maximum current limit per driver.

ELECTRICAL CHARACTERISTICS

(unless otherwise specified: $T_A = 25^\circ\text{C}$)

Characteristics	Symbol	Test conditions	Min	Typ	Max	Unit
Output leakage current (Fig.1)	I_{CEX}	$V_O = 50\text{V}, T_A = 70^\circ\text{C}$			100	μA
		$V_O = 50\text{V}, T_A = 25^\circ\text{C}$			50	
Collector-Emitter saturation voltage (Fig.2)	$V_{CE(sat)}$	$I_C = 350\text{mA}, I_B = 500\mu\text{A}$		1.1	1.6	V
		$I_C = 200\text{mA}, I_B = 350\mu\text{A}$		0.95	1.3	
		$I_C = 100\text{mA}, I_B = 250\mu\text{A}$		0.85	1.1	
Input current - on condition (Fig.4)	$I_{I(on)}$	$V_I = 3.85\text{V}$		1.1	1.35	mA
Input voltage - on condition (Fig.5)	$V_{I(on)}$	$V_{CE} = 2.0\text{V}, I_C = 200\text{mA}$		1.70	2.4	V
		$V_{CE} = 2.0\text{V}, I_C = 250\text{mA}$		1.75	2.7	
		$V_{CE} = 2.0\text{V}, I_C = 300\text{mA}$		1.80	3.0	
Input current - off condition (Fig.3)	$I_{I(off)}$	$I_C = 500\mu\text{A}, T_A = 70^\circ\text{C}$	50	100		μA
Input capacitance	C_I			15	25	pF
Turn-on delay time (50% E_I to 50% E_O)	t_{on}			0.25	1.0	μs
Turn-off delay time (50% E_I to 50% E_O)	t_{off}			0.25	1.0	μs
Clamp diode leakage current ($V_R = 50\text{V}$) (Fig.6)	I_R	$T_A = 25^\circ\text{C}$			50	μA
		$T_A = 70^\circ\text{C}$			100	
Clamp diode forward Voltage (Fig.7)	V_F	$I_F = 350\text{mA}$		1.5	2.0	V

TEST CIRCUIT

Figure 1.

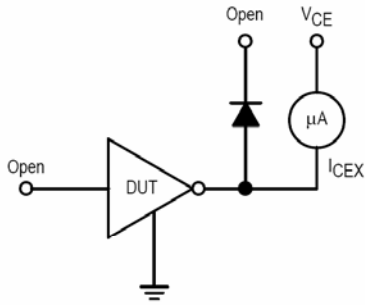

Figure 2.

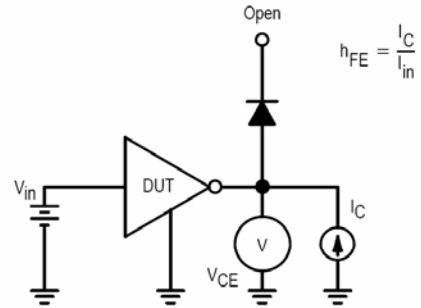

Figure 3.

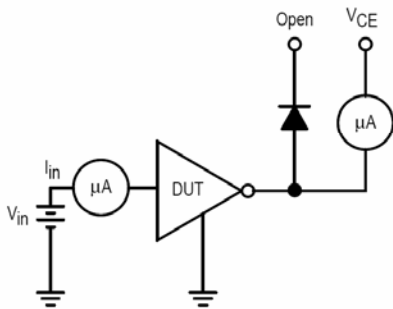

Figure 4.

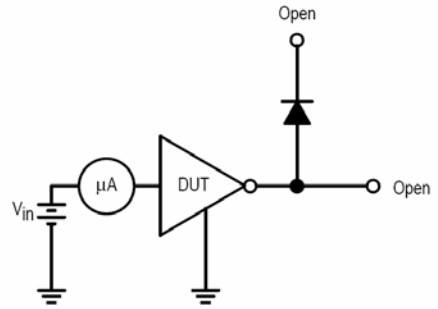

Figure 5.

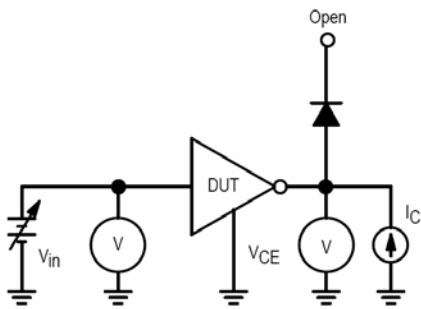

Figure 6.

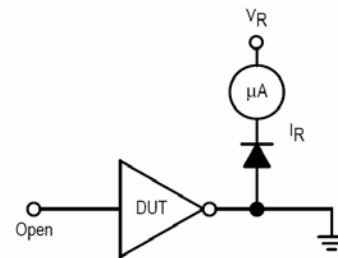
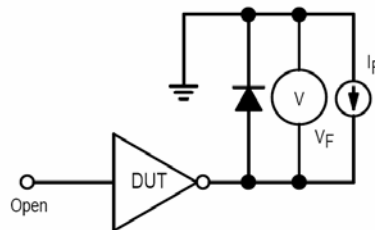
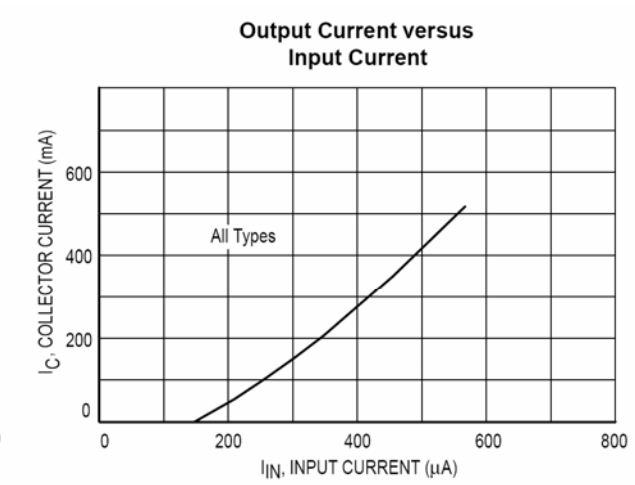
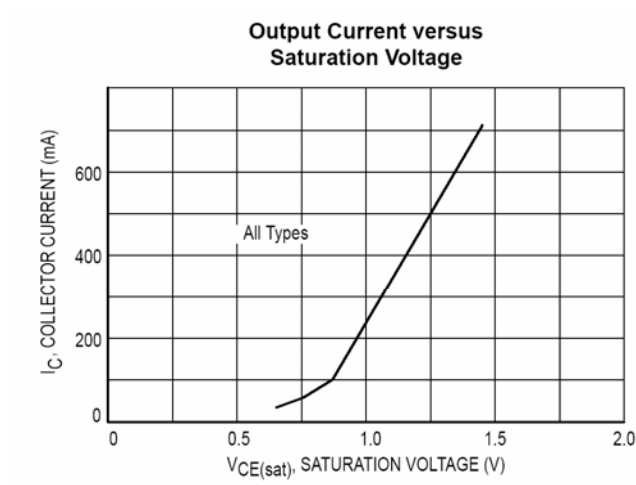

Figure 7.



TYPICAL CURVE



Input Characteristics

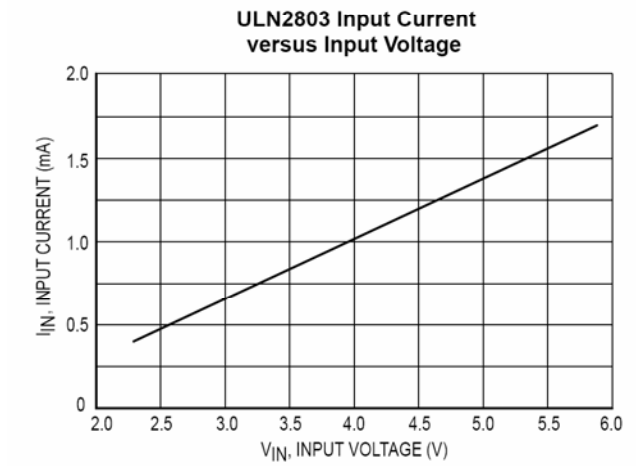

Representative Schematic Diagrams

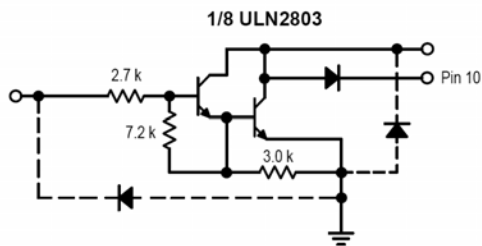

OUTLINE DRAWING

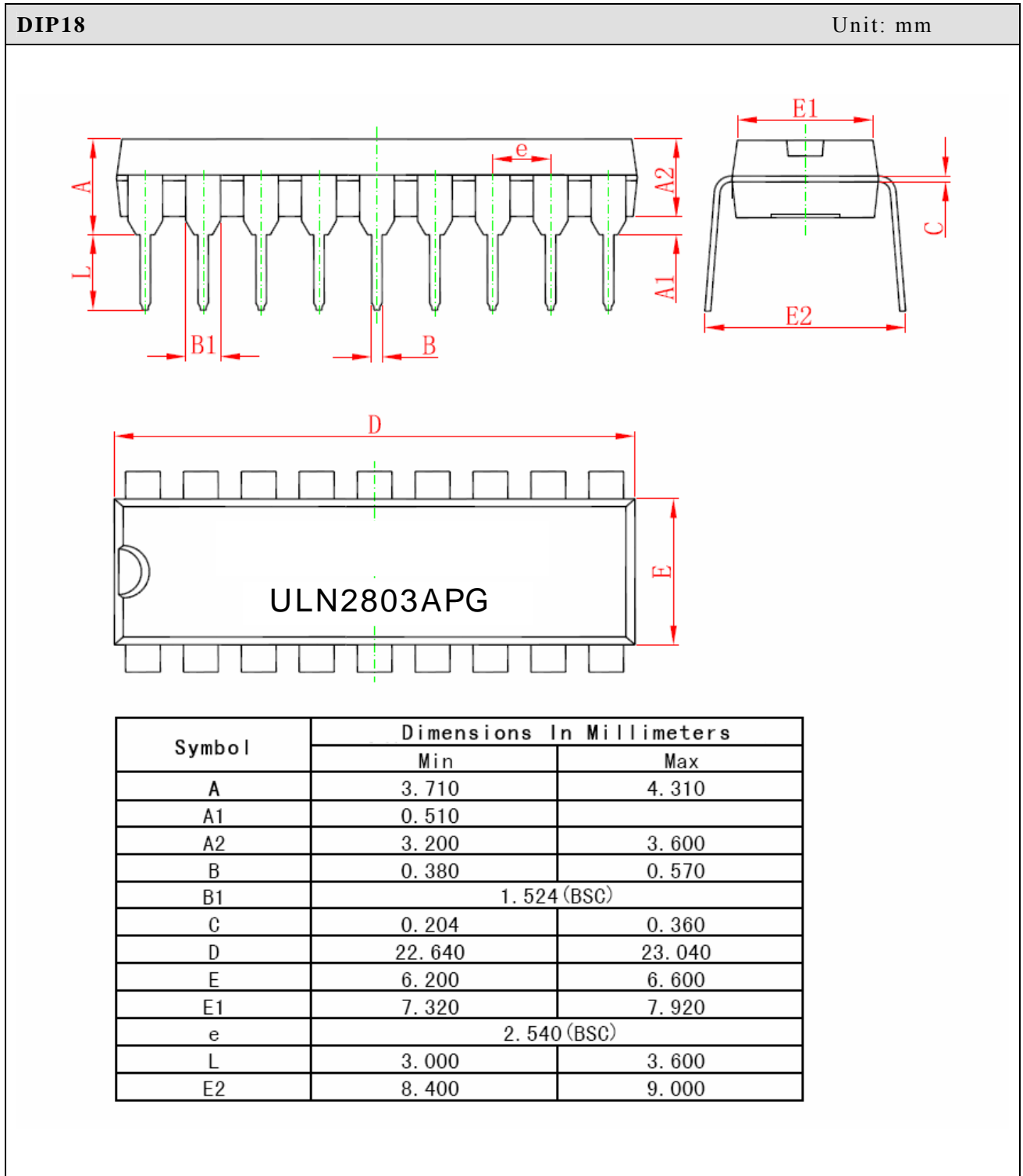

SOP18

Unit:mm

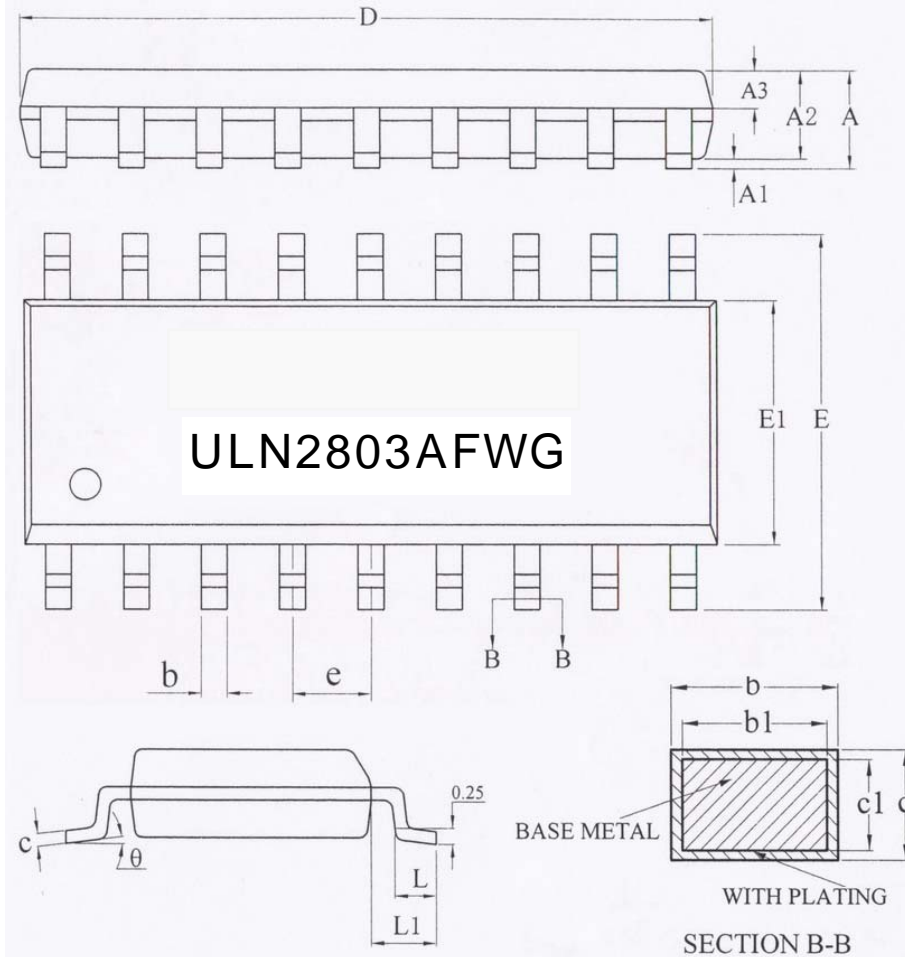

SYMBOL	MILLIMETER		
	MIN	NOM	MAX
A	—	—	2.65
A1	0.10	—	0.30
A2	2.25	2.30	2.35
A3	0.97	1.02	1.07
b	0.35	—	0.44
b1	0.34	0.37	0.39
c	0.26	—	0.31
c1	0.24	0.25	0.26
D	11.25	11.45	11.65
E	10.10	10.30	10.50
E1	7.30	7.50	7.70
e	1.27BSC		
L	0.70	—	1.00
L1	1.40BSC		
θ	0	—	8°
L/载体尺寸 (w11)	85*85		
	140*160		