

FEATURES

- **WIDEBAND OPERATION:** 900 - 2100 MHz
- **HIGH DYNAMIC RANGE:** +4.5 dBm IIP₃
- **HIGH LO-RF ISOLATION:** -40 dBm Leakage
- **VARIABLE GAIN IF AMP:** 25 dB Control Range
- **INTERNAL LO**
- **SMALL 20 PIN SSOP PACKAGE**
- **TAPE AND REEL PACKAGING OPTION AVAILABLE**

DESCRIPTION

The UPC2782GR is a Silicon Monolithic Microwave Integrated Circuit manufactured using the NESAT III process. This process produces transistors with f_T of 20 GHz. This device consists of a Gilbert cell mixer, two stages of LO buffering, local oscillator, external filter port, a high output variable gain IF amp, and a temperature compensation circuit. The device was specifically designed for digital satellite receivers, WLAN's, and other digital receiver applications.

NEC's stringent quality assurance and test procedures assure the highest reliability and performance.

INTERNAL BLOCK DIAGRAM

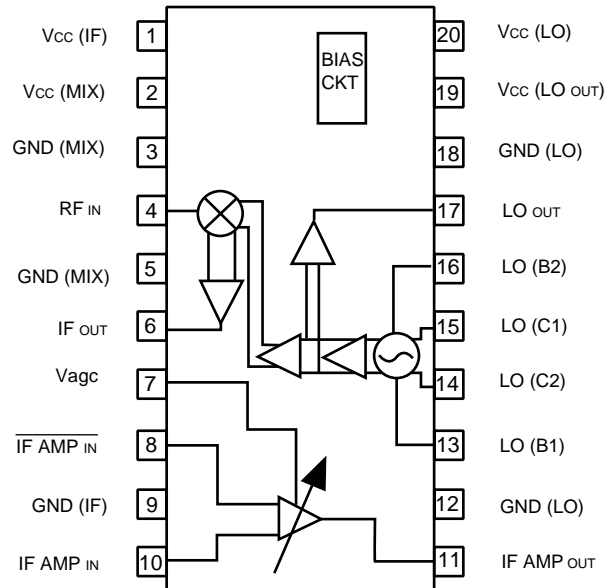

ELECTRICAL CHARACTERISTICS (T_A = 25°C, V_{CC} = 5V, P_{LO} = -10 dBm, Z_L = Z_S = 50 Ω unless otherwise specified)

PART NUMBER PACKAGE OUTLINE			UPC2782GR S20			
SYMBOLS	PARAMETERS AND CONDITIONS	UNITS	MIN	TYP	MAX	
I _{CC}	Circuit Current	mA	46	66	78	
f _{rFin}	RF Frequency Response, P _{rFin} = -20dBm, f _{iF} = 480 MHz, -3 dB down	GHz	0.9		2.1	
f _{iFout}	IF Frequency Response, P _{rFin} = -20 dBm, f _{rF} = 2.1 GHz, -3 dB down	MHz	150		500	
Mixer Section	CG	Conversion Gain ¹ , f _{rF} = 900 MHz, f _{LO} = 1380 MHz	dB	7	10	13
		f _{rF} = 2.1 GHz, f _{LO} = 2.58 GHz	dB	8	11	14
	P _{SAT}	Saturated Output Power ² , f _{rF} = 900 MHz, f _{LO} = 1380 MHz	dBm	+2	+5	
		f _{rF} = 2.1 GHz, f _{LO} = 2.58 GHz	dBm	+2	+5	
	NF	Noise Figure, f _{rF} = 900 MHz	dB		11	14
		f _{rF} = 2.1 GHz	dB		13.5	16.5
	IIP ₃	Input 3rd Order Intercept Point, f _{rF} = 900, 930 MHz, f _{LO} = 1380 MHz	dBm		0	
		f _{rF} = 2.1, 2.13 GHz, f _{LO} = 2.58 GHz	dBm		+4.5	
	IM ₃	Two-Tone 3rd Order Intermod Level,	dBc		50	
		f _{rF} = 900, 930 MHz, P _{rF} = -25 dBm each, f _{LO} = 1380 MHz	dBc		59	
	f _{rF} = 2.1, 2.13 GHz, P _{rF} = -25 dBm each, f _{LO} = 2.58 GHz	dBc				
PL _O out	Internal LO Output Power (pin 17), f _{LO} = 1.9 GHz	dBm		-15		
LO _L RF	LO Leakage to RF Pin, f _{LO} = 1.0 ~ 2.6 GHz	dBm		-40		
LO _L IF	LO Leakage to IF Pin, f _{LO} = 1.0 ~ 2.6 GHz	dBm		-20		
PN	SSB Phase Noise, 10 KHz Offset	dBc/Hz		-75		
f _O SC	Oscillator Frequency Range	GHz	1.3		2.6	

ELECTRICAL CHARACTERISTICS (con't) (TA = 25°C, Vcc = 5V, PLO = -10 dBm, ZL = Zs = 50 Ω unless otherwise specified)

PART NUMBER PACKAGE OUTLINE			UPC2782GR S20			
SYMBOLS	PARAMETERS AND CONDITIONS	UNITS	MIN	TYP	MAX	
IF AGC Section	GIF	Gain, fIF = 480 MHz, PIF = -30 dBm, VAGC = 0 V	dB	20	23	26
	PSAT, IF	Saturated Output Power, fIF = 480 MHz, PIF = 0 dBm, VAGC = 0 V	dBm	+5	+8	
	ΔGAGC	Gain Control Range, fIF = 480 MHz, PIF = -30 dBm, VAGC = 0~5 V	dB	20	25	
	NFIF	Noise Figure, fIF = 480 MHz, VAGC = 0 V	dB		12	15
	RLIFin	IF Input Return Loss	dB		12	
	RLIFout	IF Output Return Loss	dB		12	
	OIP3	IF Output 3rd Order Intercept Point, fIF = 480, 510 MHz, POUT = -5 dBm, VAGC = 0 V	dBm		+15.5	

Notes:

1. PRFin = -30 dBm
2. PRFin = 0 dBm

ABSOLUTE MAXIMUM RATINGS¹ (TA = 25°C)

SYMBOLS	PARAMETERS	UNITS	RATINGS
Vcc	Supply Voltage	V	6.0
PD	Power Dissipation ²	mW	430
TOP	Operating Temperature	°C	-40 to +85
TSTG	Storage Temperature	°C	-55 to +150

Notes:

1. Operation in excess of any one of these parameters may result in permanent damage.
2. Mounted on a 50 x 50 x 1.6 mm epoxy glass PWB (TA = +85°C).

**RECOMMENDED
OPERATING CONDITIONS**

SYMBOLS	PARAMETERS	UNITS	MIN	TYP	MAX
Vcc	Supply Voltage	V	4.5	5.0	5.5
TOP	Operating Temperature	°C	-40	+25	+85
PLOin	LO Input Level	dBm	-15	-10	0
fRFin	RF Input Frequency	GHz	0.9		2.5
fIFout	IF Output Frequency	MHz	150		500

TYPICAL PERFORMANCE CURVES (TA = 25°C, VCC = 5 V)

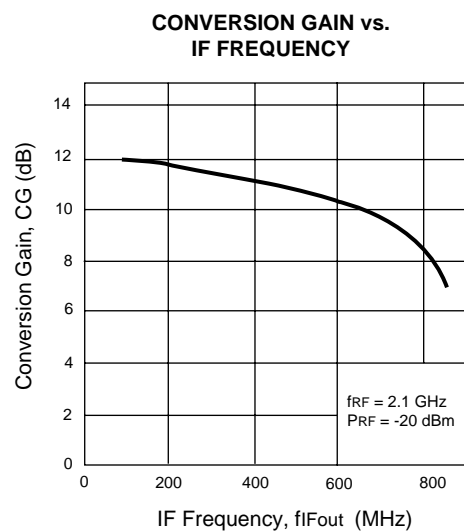
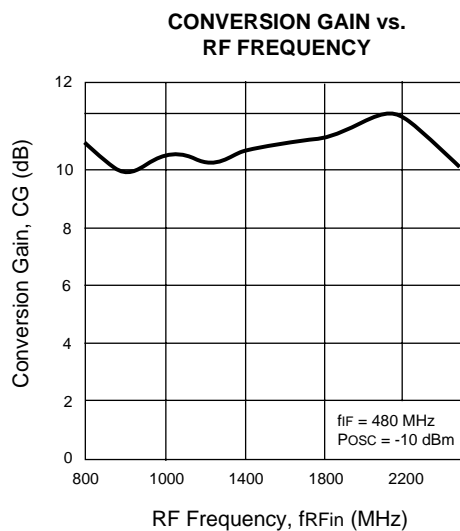

TYPICAL PERFORMANCE CURVES (TA = 25°C, VCC = 5 V)

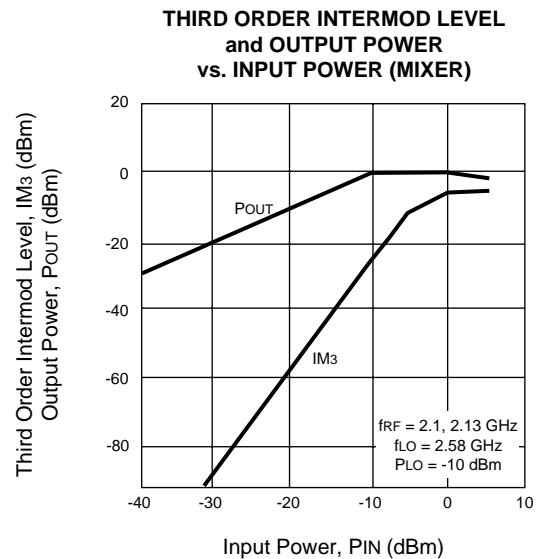
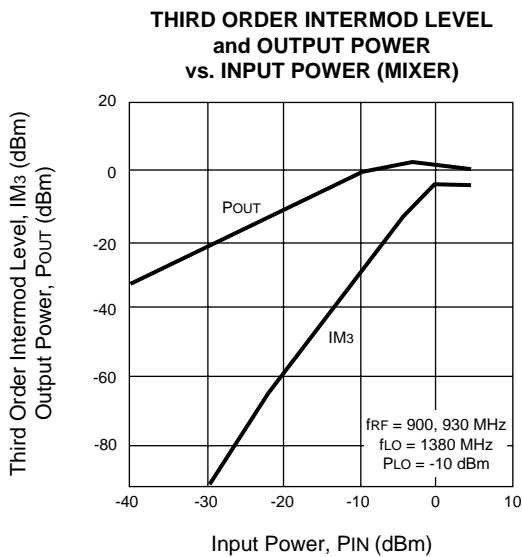
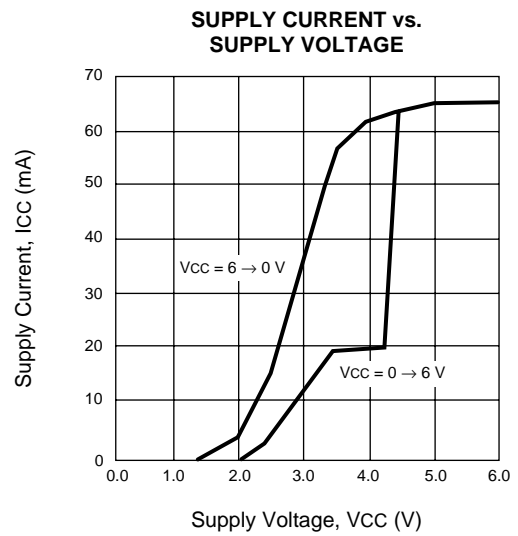
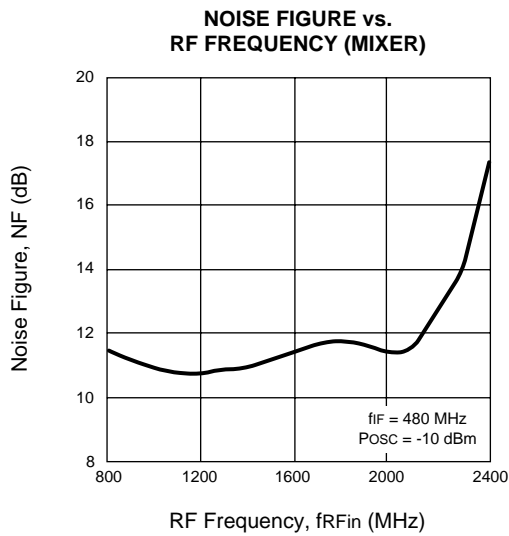
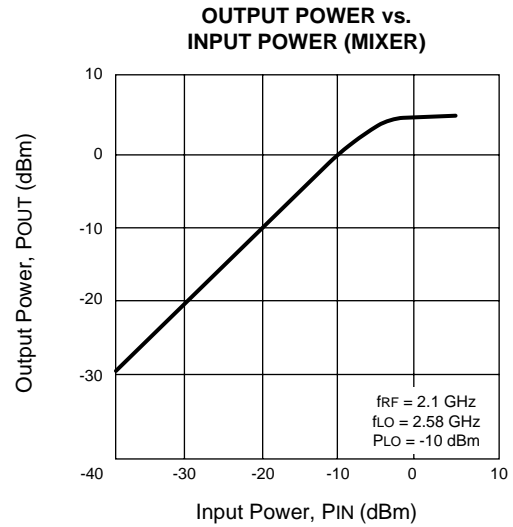
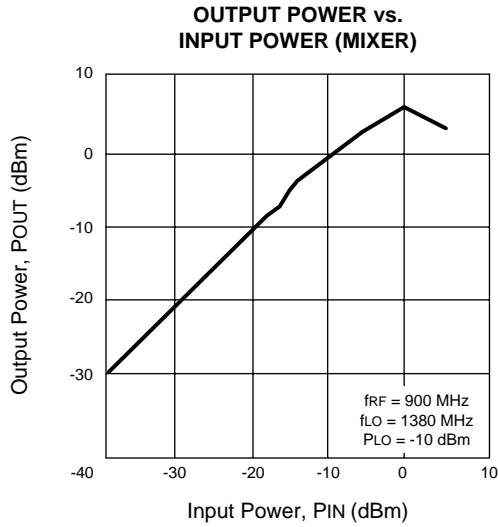

TYPICAL PERFORMANCE CURVES (TA = 25°C, VCC = 5 V)

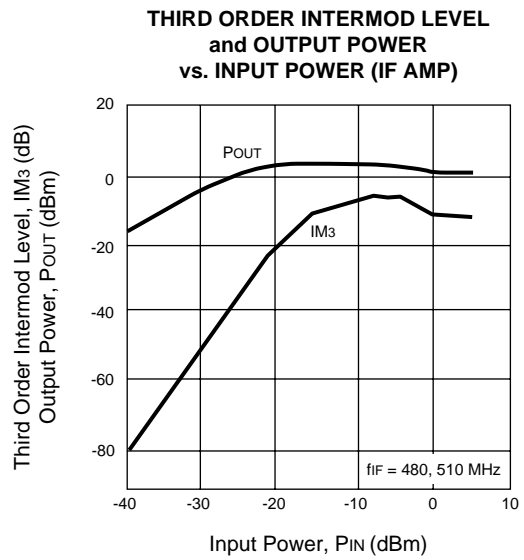
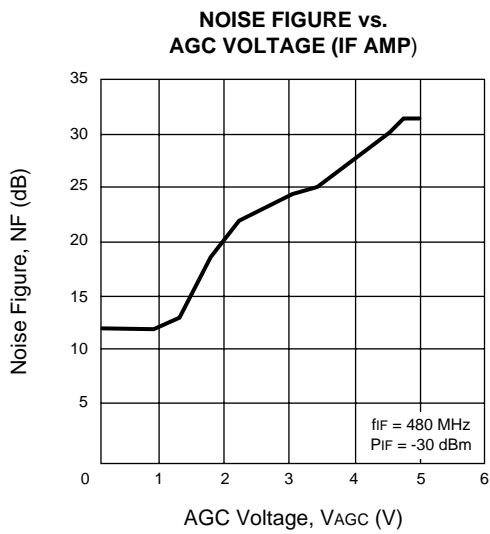
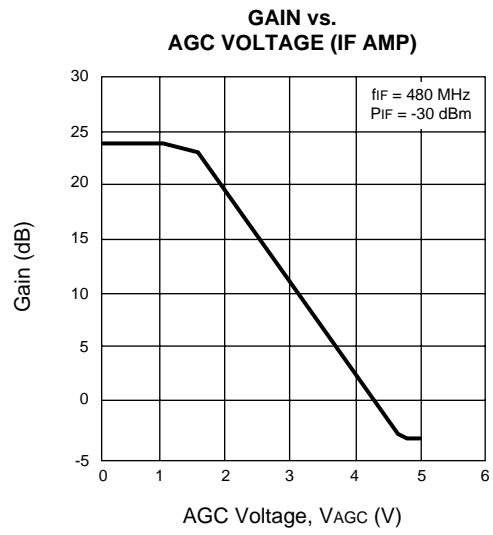
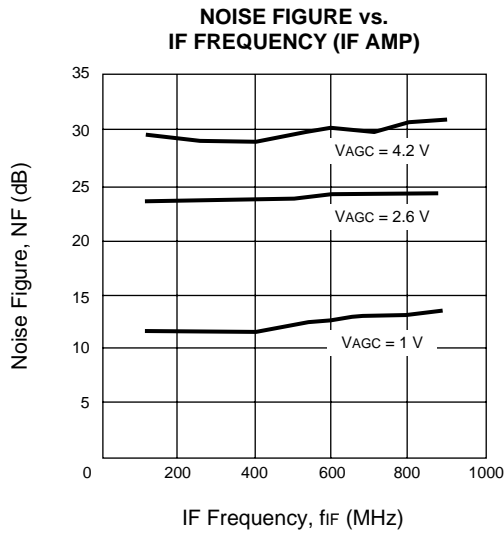
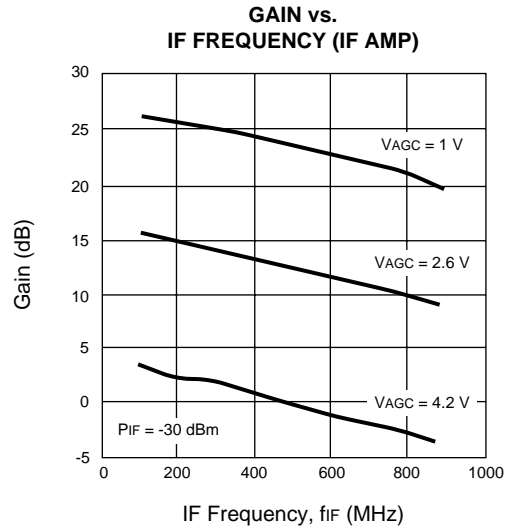
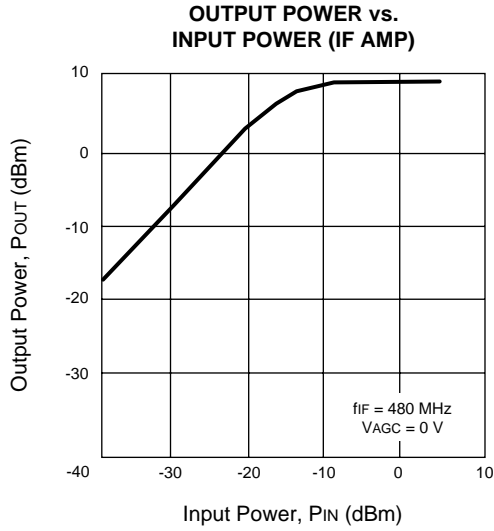

PIN CONNECTIONS

PIN NO.	SYMBOL	PIN VOLT TYP (V)	FUNCTIONS AND EXPLANATION	EQUIVALENT CIRCUIT
1	Vcc (IF)	5.00	Power supply pin of IF AGC Amp.	
2	Vcc (MIX)	5.00	Power supply pin of mixer.	
3	GND (MIX)	0.00	Ground pin of mixer.	
4	RF IN	2.00	RF signal input pin.	
5	GND (MIX)	0.00	Ground pin of mixer.	
6	IF OUT	1.85	Output pin of mixer. This pin is assigned for the emitter follower output.	
7	VAGC	0 to 5	Gain control pin. This pin's bias governs the AGC output level. Maximum gain at VAGC = 0 V Minimum gain at VAGC = 5 V	
8	IF IN	2.36	IF signal input pin of IF AGC Amp. In case of single input, this pin should be grounded through a 1000 pF capacitor.	
9	GND (IF)	0.00	Ground pin of IF AGC Amp.	
10	IF IN	2.36	IF signal input pin of IF AGC Amp.	

PIN CONNECTIONS

PIN NO.	SYMBOL	PIN VOLT TYP (V)	FUNCTIONS AND EXPLANATION	EQUIVALENT CIRCUIT
11	IF OUT	2.55	Output pin of IF AGC Amp. This pin is assigned for emitter follower push-pull output.	
12	GND (LO)	0.00	Ground pin of oscillator amplifier. Buffer amplifier, oscillator output.	
13	LO (B1)	2.30	Base Pin of oscillator. Connected to 14 pin through a capacitor.	
14	LO (C2)	5.00	Collector pin of oscillator. Connected to 15 pin through capacitor. Oscillator frequency bandwidth is dependent on this capacitor. This pin should be connected to Vcc through a 150 Ω resistor.	
15	LO (C1)	5.00	Collector pin of oscillator. Connected to 14 pin through capacitor. This pin should be connected to Vcc through a 150 Ω resistor.	
16	LO (B2)	2.30	Base pin of oscillator. Connected to 15 pin through capacitor. Assemble LC resonator between 13 pin and 16 pin through 2 pF capacitor to oscillate.	
17	LO OUT	3.15	Output pin of oscillator. This pin is assigned for emitter follower output.	
18	GND (LO)	0.00	Ground pin of oscillator amplifier, buffer amplifier, oscillator output.	
19	Vcc (LO)	5.00	Power supply pin of oscillator output.	
20	Vcc (LO)	5.00	Power supply pin of oscillator amplifier, buffer amplifier.	

PORT IMPEDANCES

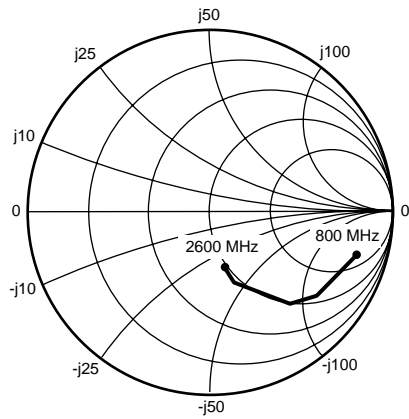

RFin (PIN 4)

<u>f (MHz)</u>	<u>MAG</u>	<u>ANG</u>
800	0.849	-13.9
1000	0.820	-18.4
1200	0.791	-24.0
1400	0.767	-30.2
1600	0.718	-38.9
1800	0.635	-45.9
2000	0.567	-53.0
2200	0.485	-58.6
2400	0.402	-66.3
2600	0.290	-76.2

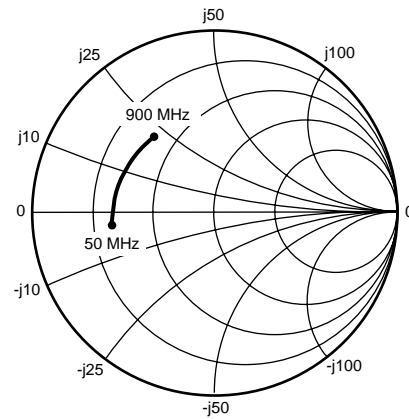

IFout (PIN 6)

<u>f (MHz)</u>	<u>MAG</u>	<u>ANG</u>
50	0.586	-175.3
100	0.562	174.9
200	0.571	165.0
300	0.566	156.4
400	0.559	149.6
500	0.560	144.1
600	0.550	139.5
700	0.548	135.8
800	0.540	132.9
900	0.538	130.6

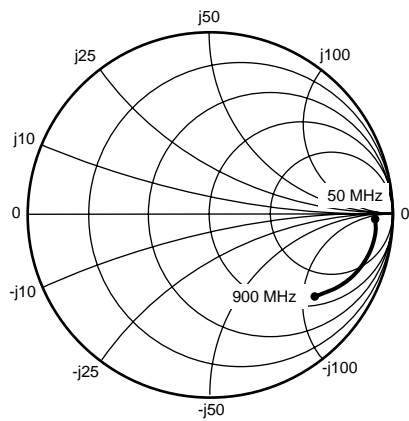

IF AMPin (PIN 10)

<u>f (MHz)</u>	<u>MAG</u>	<u>ANG</u>
50	0.894	-1.7
100	0.890	-3.6
200	0.891	-5.9
300	0.890	-9.6
400	0.884	-13.6
500	0.868	-17.9
600	0.839	-22.2
700	0.805	-26.2
800	0.769	-29.8
900	0.737	-33.0

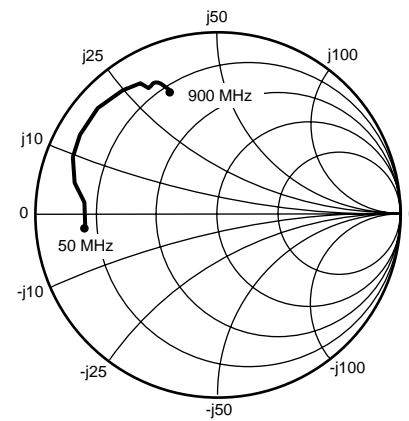

IF AMPout (PIN 11)

<u>f (MHz)</u>	<u>MAG</u>	<u>ANG</u>
50	0.750	-173.7
100	0.755	178.5
200	0.802	171.0
300	0.847	161.2
400	0.865	151.4
500	0.875	142.7
600	0.864	134.0
700	0.830	128.2
800	0.799	121.1
900	0.791	115.4

OUTLINE DIMENSIONS (Units in mm)

PACKAGE OUTLINE S20

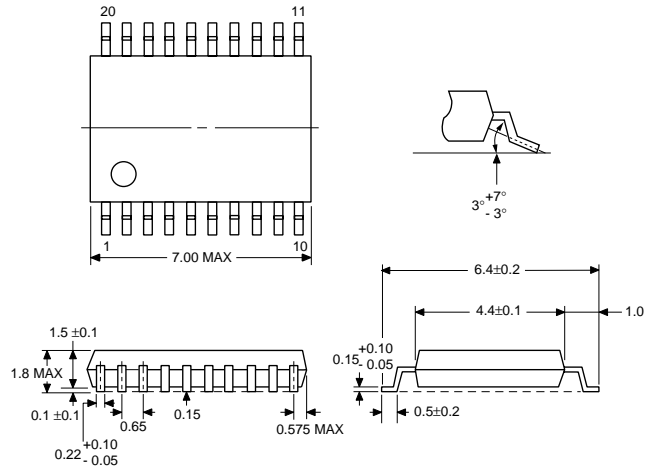

Lead Material: Alloy 42
Lead Plating: Lead Tin Alloy

ORDERING INFORMATION

PART NUMBER	QTY
UPC2782GR-E1	2,500/Reel

PIN CONNECTIONS

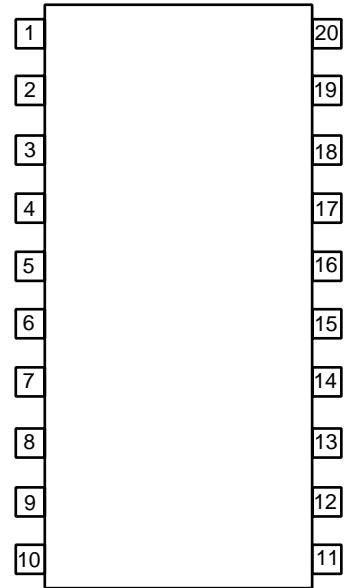

PIN CONNECTIONS:

- | | |
|--------------|-----------------|
| 1. Vcc (IF) | 20. Vcc (LO) |
| 2. Vcc (MIX) | 19. Vcc (LOOUT) |
| 3. GND (MIX) | 18. GND (LO) |
| 4. RFIN | 17. LOOUT |
| 5. GND (MIX) | 16. LO (B2) |
| 6. IFOUT | 15. LO (C1) |
| 7. VAGC | 14. LO (C2) |
| 8. IF AMPIN | 13. LO (B1) |
| 9. GND (IF) | 12. GND (LO) |
| 10. IF AMPIN | 11. IF AMPOUT |