

1/128 DUTY LCD CONTROLLER/DRIVER WITH FOUR-LEVEL GRAY SCALE, ON-CHIP RAM

DESCRIPTION

The μ PD16498 is a controller/driver which includes display RAM for full-dot LCDs that can provide a four-level gray scale display. This IC is able to drive full-dot LCDs that contain up to 128 x 128 dots.

FEATURES

- LCD controller/driver with on-chip display RAM
- Full dot outputs: 128 segment outputs and 128 common outputs
- Static icon outputs: 20 segment outputs and 2 common outputs (same signal is output)
- Can operate using single power supply (logic system) in range from 1.7 to 3.6 V.
- Selection of four levels of gray scales from among 33 possible levels (four-frame rate control + 8 pulse width modulation)
- Serial data input and 8-bit parallel data input (i80 series interface and M68 series interface)
- Dot display RAM: 128 x 128 x 2 bits
- On-chip booster: Switchable from x2 to x9 modes
- Selectable bias levels: 1/12 to 1/7 bias (normal display), 1/6 or 1/5 bias (partial display)
- Duty settings: 1/128 to 1/1 duty
- On-chip voltage divider resistor
- On-chip oscillator

ORDERING INFORMATION

Part Number	Package
μ PD16498P	Chip
μ PD16498W	Wafer

Remark Purchasing the chip/wafer entails the exchange of documents such as a separate memorandum or product quality, so please contact one of our sales representative.

The information in this document is subject to change without notice. Before using this document, please confirm that this is the latest version.
Not all devices/types available in every country. Please check with local NEC representative for availability and additional information.

TABLE OF CONTENTS

1. BLOCK1. BLOCK DIAGRAM 5

2. PIN CONFIGURATION (PAD LAYOUT) 6

3. PIN FUNCTIONS 10

3.1 Power Supply System Pins 10

3.2 Logic System Pins 11

3.3 Driver-Related Pins 13

3.4 Test Pins 14

4. PIN I/O CIRCUITS AND RECOMMENDED CONNECTION OF UNUSED PINS 15

5. DESCRIPTION OF FUNCTIONS 16

5.1 CPU Interface 16

 5.1.1 Selection of interface type 16

 5.1.2 Parallel interface 16

 5.1.3 Serial interface 18

 5.1.4 Chip select 18

 5.1.5 Display data RAM and on-chip register access 18

5.2 Display Data RAM 21

 5.2.1 Display data RAM 21

 5.2.2 X address circuit 21

 5.2.3 Column address circuit 23

 5.2.4 Y address circuit 23

 5.2.5 Common scan circuit 23

 5.2.6 Display start line set 23

 5.2.7 Display data latch circuit 23

5.3 Blink/Reverse Display Circuit 24

5.4 Oscillator 26

5.5 Display Timing Generator 30

5.6 Power Supply Circuit 31

 5.6.1 Booster 31

 5.6.2 Voltage regulator 33

 5.6.3 Use of op amp for level power supply control 36

 5.6.4 Application examples of power supply circuits 37

5.7 LCD Display Drivers 40

 5.7.1 Full-dot pulse width modulation 40

 5.7.2 Full-dot frame rate control 45

 5.7.3 Line shift driver 46

 5.7.4 Display size settings 48

 5.7.5 Setting of LCD AC driver's inversion cycle and AC driver's inversion position 48

5.8 Display Modes	50
5.8.1 Partial display mode	50
5.8.2 Monochrome (black/white) display	52
5.8.3 Icon display	54
5.9 Reset	56
6. COMMAND REGISTERS	57
6.1 Control Register 1 (R0)	58
6.2 Control Register 2 (R1)	59
6.3 Reset Command (R2)	60
6.4 X Address Register (R3)	60
6.5 Y Address Register (R4)	60
6.6 Duty Setting Register (R5)	61
6.7 AC Driver Inversion Cycle Register (R6)	61
6.8 AC Driver Inversion Position Shift Register (R7)	62
6.9 Partial AC Driver Inversion Cycle Register (R8)	62
6.10 Partial AC Driver Inversion Position Shift Register (R9)	63
6.11 Partial Display Mode Setting Register (R10)	63
6.12 Display Memory Access Register (R11).....	64
6.13 Display Start Line Setting Register (R12)	64
6.14 Blink X Address Register (R13)	64
6.15 Blink Start Line Address Register (R14)	65
6.16 Blink End Line Address Register (R15)	65
6.17 Blink Data Memory Access Register (R16)	65
6.18 Inverted X Address Register (R17)	66
6.19 Inversion Start Line Address Register (R18)	66
6.20 Inversion End Line Address Register (R19)	66
6.21 Inverted Data Memory (R20)	67
6.22 Partial Start Line Address Register (R21)	67
6.23 Gray Scale Data Registers 1 to 4 (R23 to R26)	68
6.24 Partial Gray Scale Data Registers 1 to 4 (R27 to R30)	68
6.25 Power System Control Register 1 (R32)	69
6.26 Power System Control Register 2 (R33)	70
6.27 Power System Control Register 3 (R34)	71
6.28 Electronic Volume Register (R35)	72
6.29 Partial Electronic Volume Register (R36)	72
6.30 Boost Adjustment Register (R37)	72
6.31 Static Icon Address Register (R40)	73
6.32 Static Icon Data Register (R41)	73
6.33 Static Icon Contrast Register (R42)	73
6.34 RAM Test Mode Setting Register (R44)	74
6.35 Signature Read Register (R45)	74
7. LIST OF μPD16498 REGISTERS	75

8. POWER SUPPLY SEQUENCE 76

8.1 Power ON Sequence (When Using On-Chip Power Supply, Power Supply ON → Display ON) 76

8.2 Power OFF Sequence (When Using On-Chip Power Supply) 77

8.3 Power ON Sequence (When Using External Driver Power Supply, Power ON → Display ON) 77

8.4 Power Supply OFF Sequence (When Using External Driver Power Supply) 78

8.5 V_{OUT}, V_{LCD} Voltage Sequence (Power ON → Power OFF) 79

9. USE OF RAM TEST MODE 80

10. USE OF STANDBY/HALT MODE 81

11. ELECTRICAL SPECIFICATIONS 82

12. CPU INTERFACE (REFERENCE EXAMPLE) 91

1. BLOCK DIAGRAM

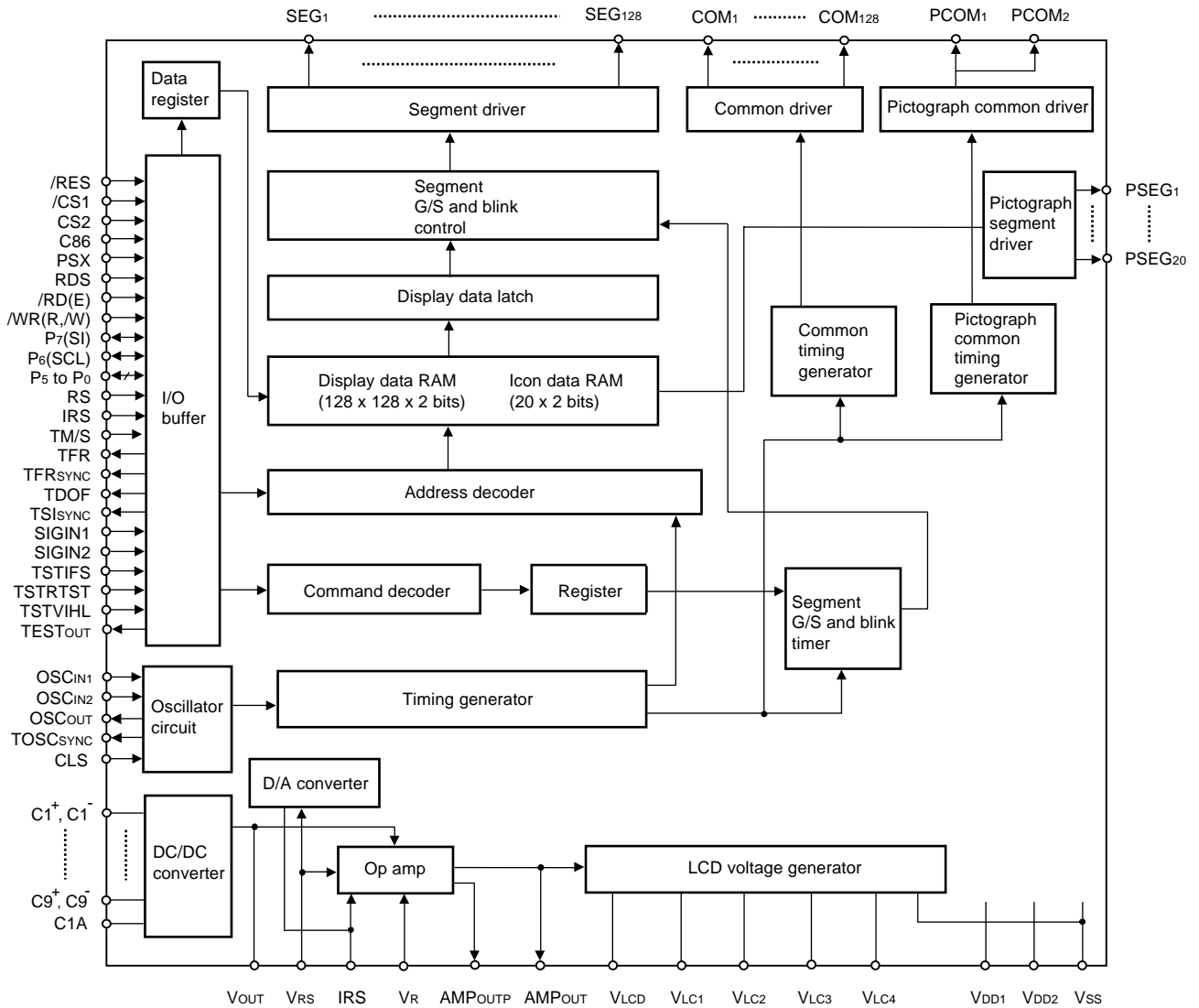

Remark /xxx indicates active low signals.

2. PIN CONFIGURATION (PAD LAYOUT)

Chip size : 3.0 x 11.4 mm²
 Chip : 485 μm TYP.

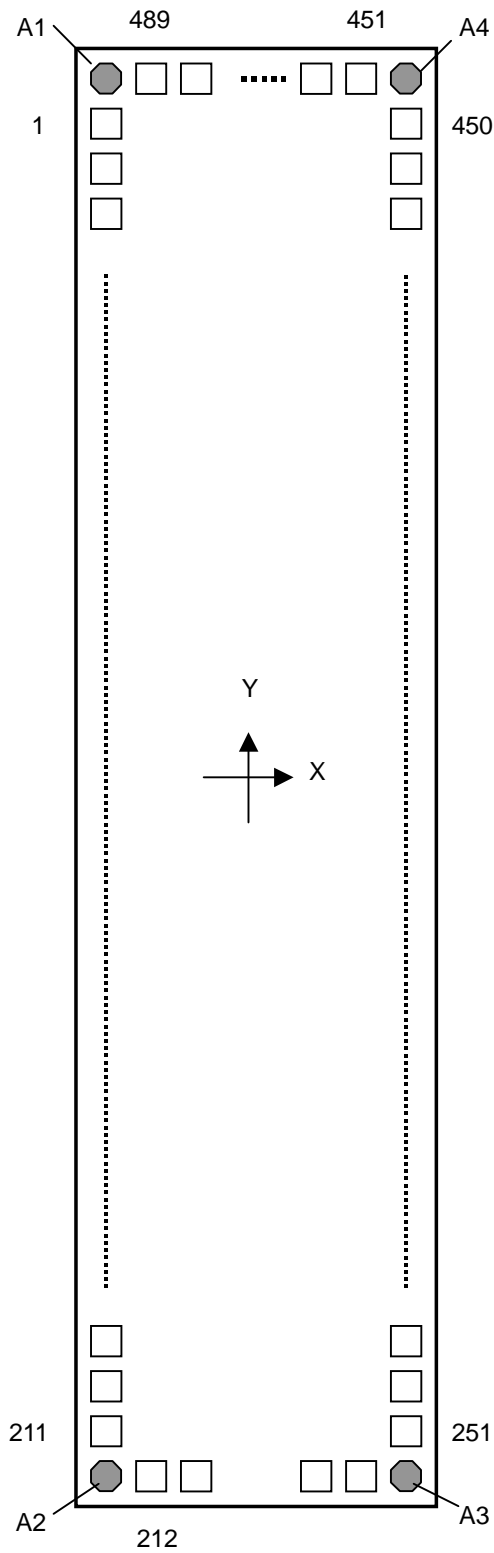

• μPD16498 Pad Layout (3/3)

Pad No.	Pin Name	Pad Type	Pad Coordinate	
			X[μm]	Y[μm]
421	COM119	A	1282.760	3525.000
422	COM117	A	1282.760	3575.000
423	COM115	A	1282.760	3625.000
424	COM113	A	1282.760	3675.000
425	COM111	A	1282.760	3725.000
426	COM109	A	1282.760	3775.000
427	COM107	A	1282.760	3825.000
428	COM105	A	1282.760	3875.000
429	COM103	A	1282.760	3925.000
430	COM101	A	1282.760	3975.000
431	COM99	A	1282.760	4025.000
432	COM97	A	1282.760	4075.000
433	COM95	A	1282.760	4125.000
434	COM93	A	1282.760	4175.000
435	COM91	A	1282.760	4225.000
436	COM89	A	1282.760	4275.000
437	COM87	A	1282.760	4325.000
438	COM85	A	1282.760	4375.000
439	COM83	A	1282.760	4425.000
440	COM81	A	1282.760	4475.000
441	COM79	A	1282.760	4525.000
442	COM77	A	1282.760	4575.000
443	COM75	A	1282.760	4625.000
444	COM73	A	1282.760	4675.000
445	COM71	A	1282.760	4725.000
446	COM69	A	1282.760	4775.000
447	COM67	A	1282.760	4825.000
448	COM65	A	1282.760	4875.000
449	DUMMY	B	1282.760	5081.000
450	DUMMY	B	1282.760	5211.000
451	DUMMY	B	1041.000	5482.760
452	DUMMY	B	911.000	5482.760
453	DUMMY	B	781.000	5482.760
454	COM63	A	665.000	5482.760
455	COM61	A	615.000	5482.760
456	COM59	A	565.000	5482.760
457	COM57	A	515.000	5482.760
458	COM55	A	465.000	5482.760
459	COM53	A	415.000	5482.760
460	COM51	A	365.000	5482.760
461	COM49	A	315.000	5482.760
462	COM47	A	265.000	5482.760
463	COM45	A	215.000	5482.760
464	COM43	A	165.000	5482.760
465	COM41	A	115.000	5482.760
466	COM39	A	65.000	5482.760
467	COM37	A	15.000	5482.760
468	COM35	A	-35.000	5482.760
469	COM33	A	-85.000	5482.760
470	COM31	A	-135.000	5482.760
471	COM29	A	-185.000	5482.760
472	COM27	A	-235.000	5482.760
473	COM25	A	-285.000	5482.760
474	COM23	A	-335.000	5482.760
475	COM21	A	-385.000	5482.760
476	COM19	A	-435.000	5482.760
477	COM17	A	-485.000	5482.760
478	COM15	A	-535.000	5482.760
479	COM13	A	-585.000	5482.760
480	COM11	A	-635.000	5482.760
481	COM9	A	-685.000	5482.760
482	COM7	A	-735.000	5482.760
483	COM5	A	-785.000	5482.760
484	COM3	A	-835.000	5482.760
485	COM1	A	-885.000	5482.760
486	PCOM2	A	-935.000	5482.760
487	PCOM2	A	-985.000	5482.760
488	DUMMY	A	-1085.000	5482.760
489	DUMMY	B	-1176.000	5482.760

Pad type A:

Pad size (Al) : 43 x 73 μm² TYP.
 Bump size : 37 x 65 μm² TYP.
 Bump height : 17 μm TYP.

Pad type B:

Pad size (Al) : 118 x 73 μm² TYP.
 Bump size : 110 x 65 μm² TYP.
 Bump height : 17 μm TYP.

Alignment Mark

	Mark Center Coordinate	
	X [μm]	Y [μm]
A1	-1103.92	5193.00
A2	-1130.20	-5217.10
A3	1274.78	-5474.78
A4	1274.78	5474.78

Alignment Mark Form Coordinate (Unit : μm)

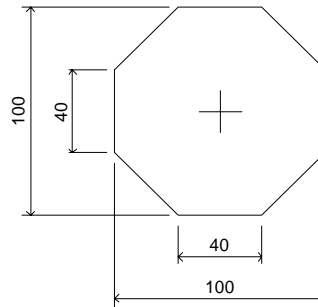

3. PIN FUNCTIONS

3.1 Power Supply System Pins

Symbol	Name	Pad No.	I/O	Description
VDD1	Logic power supply pin	92 to 94, 100, 108, 116, 126, 171	–	Power supply pin for logic circuit
VDD2	Boost circuit power supply pin	89 to 91,	–	Power supply pin for booster
VSS	Logic and driver ground pin	28, 47, 50, 95 to 97, 103, 111, 121, 129, 168, 174, 183,	–	Ground pin for logic and driver circuits
VOUT	Driver power supply pin	48, 49	–	Power supply pin for driver. Output pin for on-chip booster. Connect a 1 μF boost capacitor between this pin and the GND pin. If not using the on-chip booster, a direct driver power supply can be input.
VLCD, VLC1 to VLC4	Reference power supply pins for driver	46, 45, 44 to 37	–	These are reference power supply pins for the LCD driver. Connect a capacitor between these pins and the GND pin if an internal bias has been selected.
C1 ⁺ , C1 ⁻ C2 ⁺ , C2 ⁻ C3 ⁺ , C3 ⁻ C4 ⁺ , C4 ⁻ C5 ⁺ , C5 ⁻ C6 ⁺ , C6 ⁻ C7 ⁺ , C7 ⁻ C8 ⁺ , C8 ⁻ C9 ⁺ , C9 ⁻	Boost capacitor connection pins (1)	86, 85, 84, 83, 82, 81, 80, 79, 78, 77, 76, 75, 74, 73, 72, 71, 70, 69, 68, 67, 66, 65, 64, 63, 62, 61, 60, 59, 58, 57, 56, 55, 54, 53, 52, 51,	–	These are capacitor connection pins for the booster. When using the on-chip booster, connect a 1 μF capacitor between positive (+) and negative (-) pins.
C1A	Boost capacitor connection pin (2)	87, 88	–	This is a capacitor connection pin for boost adjustment. When using the on-chip booster, connect a 1 μF capacitor between this pin and the GND pin.

3.2 Logic System Pins

(1/2)

Symbol	Name	Pad No.	I/O	Description																											
PSX	Data transfer selection	106, 107	Input	This pin is used to select between parallel data input and serial data input. PSX = H: Parallel data input PSX = L: Serial data input																											
/CS1, CS2	Chip select	112, 113, 114, 115	Input	These pins are used for chip select signals. When /CS1 = L (CS2 = H), the chip is active and can perform data input/output operations including command and data I/O.																											
/RD (E)	Read (enable)	124, 125	Input	When i80 series parallel data transfer (/RD) has been selected, the signal at this pin is used to enable read operations. Data is output to the data bus only when this pin is L. When M68 series parallel data transfer (E) has been selected, the signal at this pin is used to enable write operations. Data is written at the falling edge of this signal.																											
/WR (R,W)	Write (read/write)	122, 123	Input	When i80 series parallel data transfer (/WR) has been selected, the signal at this pin is used to enable write operations. Data is written at the rising edge of this signal. When 68 series parallel data transfer (R,W) has been selected, this pin is used to determine the direction of data transfer. L: Write H: Read																											
C86	Interface selection	104, 105	Input	This pin is used to switch between interface modes (i80 series CPU or M68 series CPU). L: Selects i80 series CPU mode H: Selects M68 series CPU mode																											
RDS	Data pin selection	127,128	Input	This pin determines the direction of a data as follows. Fixed to low level at the time serial data input (PSX = L). <table border="1" style="margin: 10px auto;"> <tr> <td>RDS</td> <td>P7</td> <td>P6</td> <td>P5</td> <td>P4</td> <td>P3</td> <td>P2</td> <td>P1</td> <td>P0</td> </tr> <tr> <td>Low</td> <td>D7</td> <td>D6</td> <td>D5</td> <td>D4</td> <td>D3</td> <td>D2</td> <td>D1</td> <td>D0</td> </tr> <tr> <td>High</td> <td>D0</td> <td>D1</td> <td>D2</td> <td>D3</td> <td>D4</td> <td>D5</td> <td>D6</td> <td>D7</td> </tr> </table>	RDS	P7	P6	P5	P4	P3	P2	P1	P0	Low	D7	D6	D5	D4	D3	D2	D1	D0	High	D0	D1	D2	D3	D4	D5	D6	D7
RDS	P7	P6	P5	P4	P3	P2	P1	P0																							
Low	D7	D6	D5	D4	D3	D2	D1	D0																							
High	D0	D1	D2	D3	D4	D5	D6	D7																							
P0 to P5, P6 (SCL) P7 (SI)	Data bus (serial clock) (serial input)	148 to 145, 143 to 140, 138 to 135, 133, 132, 131, 130	I/O	These pins comprise an 8-bit bidirectional data bus that connects to an 8-bit or 16-bit standard CPU bus. When the serial interface has been selected (PSX = L), P6 functions as a serial clock input pin (SCL) and P7 functions as a serial data input pin (SI). In either case, pins P0 to P5 are in high impedance mode. When the chip is not selected, P0 to P7 are in high impedance mode.																											
RS	Index register/data, command selection	119, 120	Input	Usually, this pin is connected to the LSB of the standard CPU address bus and is used to distinguish between data from index registers and data/commands. RS = H: Indicates that data from D0 to D7 is data/command RS = L: Indicates that data from D0 to D7 is index register contents																											
/RES	Reset	117, 118	Input	When /RES is low, an internal reset is performed. The reset operation is executed at the /RES signal level.																											

(2/2)

Symbol	Name	Pad No.	I/O	Description
CLS	Select clock division	98, 99	Input	This pin is used to select whether or not to use the divider within the display clock oscillator. CLS = H: Use divider CLS = L: Do not use divider When using an external clock, the CLS = L setting is input via the OSC _{IN1} and OSC _{IN2} pins as normal and partial clocks respectively. When CLS = H, clock input is via the OSC _{IN1} pin only.
IRS	V _{LCD} regulation	109, 110	Input	This pin is used to select the resistor that is used for V _{LCD} voltage regulation. IRS = H: Uses internal resistor IRS = L: Does not use internal resistor. The V _{LCD} voltage level is regulated using the external voltage division resistor that is connected to the V _R pin. This pin is valid only in master operation mode. In slave operation mode, this pin is fixed high or low level.
SIGIN1, SIGIN2	Signature setting pins	169, 170, 172, 173	Input	These pins can be used to set a unique signature for the IC. The signal set via these pins can subsequently be read from the signature read register (R45).
OSC _{IN1}	Oscillation signal pins	157, 158	Input	A resistor can be inserted between OSC _{IN1} -OSC _{OUT} , and OSC _{IN2} -OSC _{OUT} . When using an external oscillator, a clock signal is input via the OSC _{IN} pins according to the CLS pin's status and the OSC _{OUT} pin is left unconnected. The wiring between OSC _{IN1} -OSC _{OUT} and OSC _{IN2} -OSC _{OUT} must be as short as possible, and use after proper evaluation.
OSC _{IN2}		159, 160	Input	
OSC _{OUT}		161, 162	Output	

3.3 Driver-Related Pins

Symbol	Name	Pad No.	I/O	Description
SEG ₁ to SEG ₁₂₈	Segment	414 to 287	Output	Segment output pins
COM ₁ to COM ₁₂₈	Common	216 to 247, 253 to 284, 417 to 448, 454 to 485	Output	Common output pins
PSEG ₁ to PSEG ₂₀	Static segment	3, 4, 6 to 9, 11 to 14, 16 to 19, 21 to 24, 26, 27, 184, 185, 187 to 190, 192 to 195, 197 to 200, 202 to 205, 207, 208	Output	Segment output pins for static icon
PCOM ₁ , PCOM ₂	Static common	214, 215, 486, 487	Output	Common output pins for static icon (Same driver waveform is output from two pins.)
V _{RS}	Op amp input pin for regulating the driving voltage of the LCD	29, 30	Input	V _{RS} is an op amp input pin for regulating the driving voltage of the LCD. This is a reference voltage input for the LCD voltage regulation amplifier. When using the internal drive circuit (i.e., when OP1 = 1), we recommend inserting a 0.1 to 1 μF capacitor between this pin and GND.
V _R	Input pin for the op amp's feedback connection	35, 36	Input	V _R is an input for the op amp's feedback connection. Insert this pin between GND and AMP _{OUT} when using the feedback resistor for this input. This pin is valid only when not using an internal resistor for V _{LCD} voltage regulation (i.e., when IRS = L). This pin cannot be used when using the internal resistor for V _{LCD} voltage regulation (i.e., when IRS = H).
AMP _{OUT}	Op amp output	33, 34	Output	These are op amp output pins for regulating the driving voltage of the LCD. When not using an internal resistor for V _{LCD} voltage regulation (i.e., when IRS = L), these outputs are connected to the LCD drive voltage regulation resistor (see 5.6.2 Voltage regulator). We recommend inserting a 0.01 to 0.1 μF capacitor between these pins in order to stabilize the internal op amp's output.
AMP _{OUTP}		31, 32		
DUMMY	Dummy pin	1, 2, 5, 10, 15, 20, 25, 134, 139, 144, 149, 154, 163, 186, 191, 196, 201, 206, 209 to 213, 248 to 252, 415, 416, 449 to 453, 488, 489	–	Dummy pin. These pins are not connected inside IC. Usually, leave these pins open.

3.4 Test Pins

Symbol	Name	Pad No.	I/O	Description
TFR	Test output	152, 153	Output	These pins are used when the IC is in test mode. Usually, leave them open.
TFR _{SYNC}		150, 151		
TDOF		155, 156		
TSI _{SYNC}		166, 167		
TOSC _{SYNC}		164, 165		
TEST _{OUT}		175, 176		
TM/S	Test input	101, 102	Input	These pins are used to set a test mode for the IC. Normally, connect these pins to V _{DD1} .
TSTIFS	Test input	177, 178	Input	These pins are used to set a test mode for the IC. Normally, connect these pins to V _{SS} .
TSTRTST		179, 180		
TSTVIHL		181, 182		

4. PIN I/O CIRCUITS AND RECOMMENDED CONNECTION OF UNUSED PINS

The I/O circuit type of each pin and recommended connection of unused pins are described below.

Pin Name	Input Type	Input/output	Recommended Connection of Unused Pins	Notes
PSX	Schmitt trigger	Input	Mode setting pin.	Note 1
/CS1	Filter	Input	Connect to Vss.	–
CS2	Filter	Input	Connect to VDD1.	–
/RD(E)	Filter	Input	Connect to VDD1 (i80 series interface), connect to VDD1 or Vss (serial interface).	–
/WR(R,W)	Filter	Input	Connect to VDD1 or Vss (serial interface).	–
C86	Schmitt trigger	Input	Mode setting pin.	Note 1
RDS	Schmitt trigger	Input	Mode setting pin.	Note 1
P0 to P5	Filter	Input/output	Leave open	–
P6(SCL)	Filter	Input/output	–	–
P7(SI)	Filter	Input/output	–	–
RS	Filter	Input	Register setting pin.	Note 2
/RES	Schmitt trigger	Input	Connect to VDD1.	–
CLS	Schmitt trigger	Input	Mode setting pin	Note 1
IRS	Schmitt trigger	Input	Mode setting pin.	Note 1
SIGIN1	Schmitt trigger	Input	Connect to VDD1 or Vss.	–
SIGIN2	Schmitt trigger	Input	Connect to VDD1 or Vss.	–
OSCIN1	Schmitt trigger	Input	–	–
OSCIN2	Schmitt trigger	Input	Connect to VDD1 or Vss (CLS = H)	–
OSCOU	–	Output	Leave open (when using external clock)	–
TFR	CMOS	Output	Leave open	–
TFRSYNC	CMOS	Output	Leave open	–
TDOF	CMOS	Output	Leave open	–
TSISYNC	CMOS	Output	Leave open	–
TM/S	Schmitt trigger	Input	Connect to VDD1	–
TOSCSYNC	–	Output	Leave open	–
TSTIFS	Schmitt trigger	Input	Connect to Vss (during normal use)	–
TSTRTST	Schmitt trigger	Input	Connect to Vss (during normal use)	–
TSTVIHL	Schmitt trigger	Input	Connect to Vss (during normal use)	–
TESTOUT	–	Output	Leave open	–

- Notes 1.** Connect to either VDD1 or Vss, depending on the mode setting.
2. Input either VDD1 or Vss output from CPU, depending on the mode setting.

5. DESCRIPTION OF FUNCTIONS

5.1 CPU Interface

5.1.1 Selection of interface type

The μPD16498 chip transfers data using an 8-bit bidirectional data bus (P₇ to P₀) or a serial data input (SI). Setting the polarity of the PSX pin as either H (high) or L (low) selects between 8-bit parallel or serial data input, as shown in the following table.

PSX	CS	RS	/RD	/WR	C86	RDS	P ₇	P ₆	P ₅	P ₄	P ₃	P ₂	P ₁	P ₀
H: Parallel input	CS	RS	/RD	/WR	C86	L	D ₇	D ₆	D ₅	D ₄	D ₃	D ₂	D ₁	D ₀
						H	D ₇	D ₆	D ₅	D ₄	D ₃	D ₂	D ₁	D ₀
L: Serial input	CS	RS	Note1	Note1	Note1	L Note2	SI	SCL	Hi-Z ^{Note3}					

- Notes**
1. Fixed as either High or Low.
 2. Fix the RDS pin to Low level when the serial interface has been selected (PSX = L).
 3. Hi-Z: High impedance

5.1.2 Parallel interface

When the parallel interface has been selected (PSX = H), setting the C86 pin as either H or L enables a direct connection to an i80 series or M68 series CPU (see table below).

C86	/CS1	CS2	RS	/RD	/WR	P ₇ to P ₀
H: M68 series CPU	/CS1	CS2	RS	E	R, <i>W</i>	D ₇ to D ₀
L: i80 series CPU	/CS1	CS2	RS	/RD	/WR	D ₇ to D ₀

The data bus signal is identified according to the combination of the RS, /RD(E), and /WR(R,*W*) signals, as shown in the following table.

Common	M68	i80		Function
		/RD	/WR	
RS	R, <i>W</i>			
1	1	0	1	Reads display data and registers
1	0	1	0	Writes display data and registers
0	1	0	1	Prohibited
0	0	1	0	Writes to index register

(1) i80 series parallel interface

When i80 series parallel data transfer has been selected, data is written to the μPD16498 at the rising edge of the /WR signal. The data is output to the data bus when the /RD signal is L.

Figure 5-1. i80 Series Interface Data Bus Status

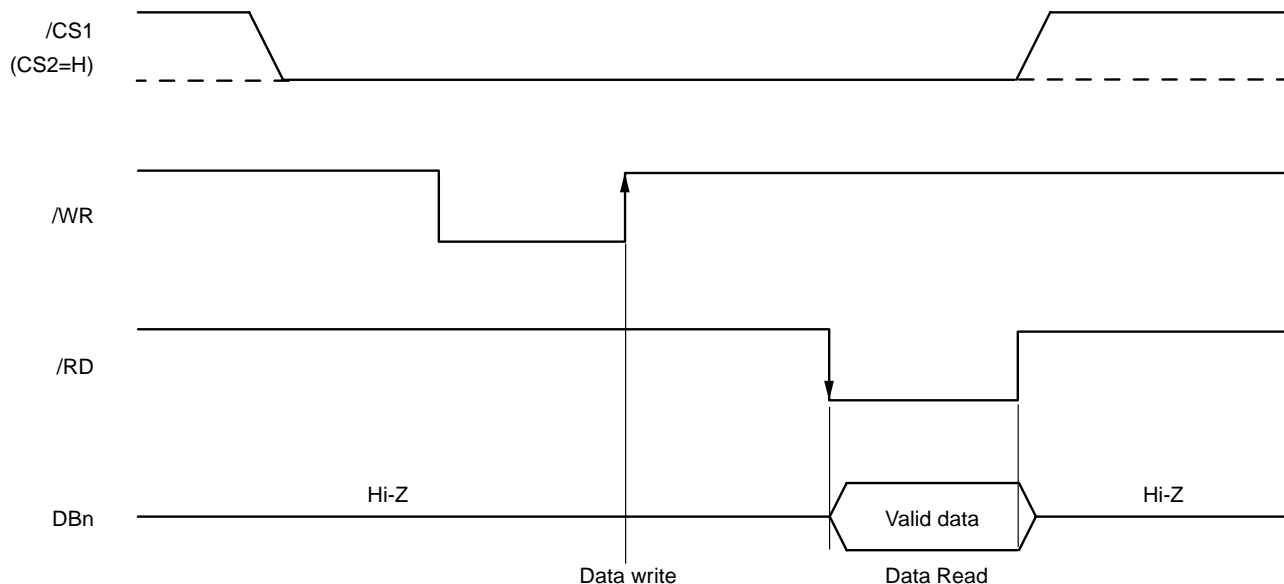

(2) M68 series parallel interface

When M68 series parallel data transfer has been selected, data is written at the falling edge of the E signal when the R,/W signal is L. During the data read operation, the data bus enters the output status when the R,/W signal is H, outputs valid data at the rising edge of the E signal, and enters the high-impedance state at the falling edge of the R,/W signal (R,/W = L)

Figure 5-2. M68 Series Interface Data Bus Status

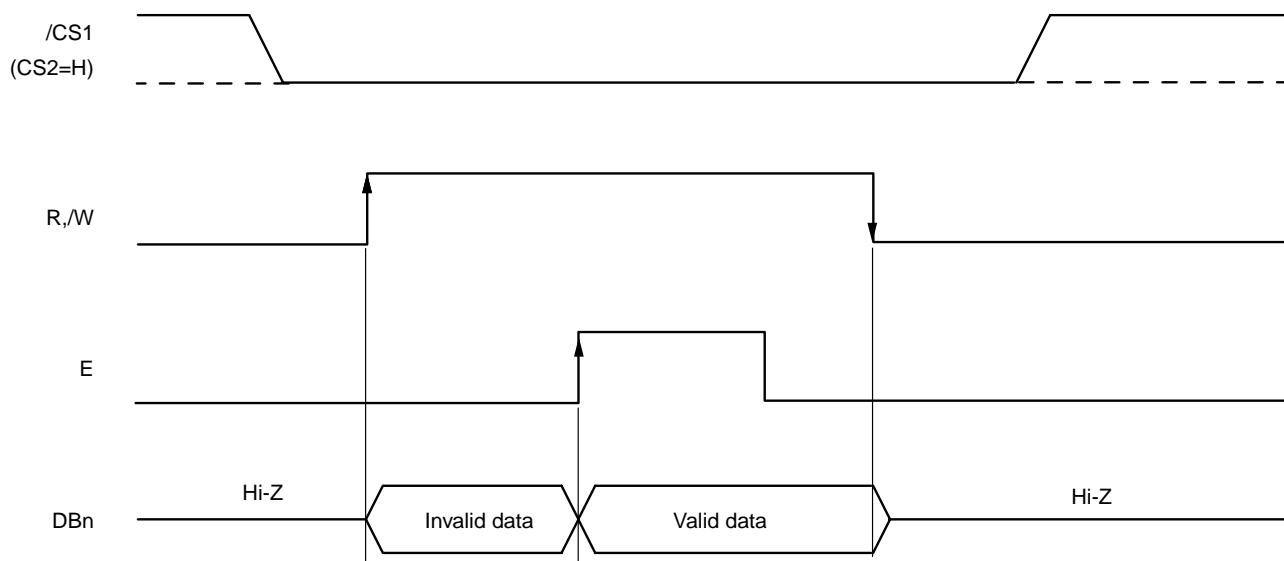

5.1.3 Serial interface

When the serial interface has been selected (PSX = L), if the chip is active ($\overline{\text{CS1}} = \text{L}$, CS2 = H), serial data input (SI) and serial clock input (SCL) can be received. Serial data is read from D₇ and then from D₆ to D₀ on the rising edge of the serial clock, via the serial input pin. This data is synchronized on the eighth serial clock's rising edge and is then converted to parallel data for processing. RS input is used to judge serial input data as display data or command data: when RS = H the data is display/command data and when RS = L the data is index data. When the chip enters active mode, RS input is read at the rising edge after every eighth serial clock and is then used to judge the serial input data. The serial interface signal chart is shown below.

Figure 5-3. Serial Interface Signal Chart

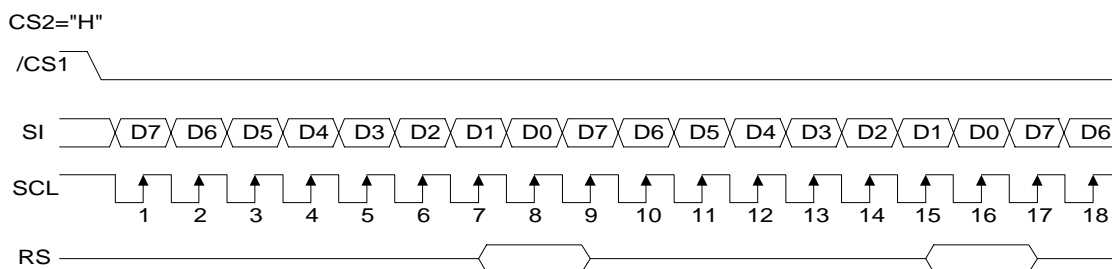

- Remarks 1.** If the chip is not active, the shift register and counter are reset to their initial settings.
2. The data read function is disabled during serial interface mode.
 3. When using SCL wiring, take care concerning the possible effects of terminating reflection and noise from external sources. We recommend checking operation with the actual device.

5.1.4 Chip select

The μPD16498 has two chip select pins ($\overline{\text{CS1}}$ and CS2). The CPU parallel interface or serial interface can be used only when $\overline{\text{CS1}} = \text{L}$ and CS2 = H. When chip select is inactive, P₀ to P₇ are set to high impedance (invalid) and input of RS, $\overline{\text{RD}}$, or $\overline{\text{WR}}$ is not active. If serial interface mode has been set, the shift register and counter are both reset.

5.1.5 Display data RAM and on-chip register access

Because only the required cycle time (t_{cyc}) is satisfied when accessing the μPD16498 from the CPU, high-speed data transfer is possible. There is no need to consider any wait time. No dummy data is needed when writing data. Even when data is read, there is no need for dummy data except in the display memory access register (R11).

In other words, dummy data is required only when reading data from the display memory access register (R11).

Figure 5-4 illustrates this relationship.

Figure 5-4. Write and Read (1/2)

Write

<CPU>

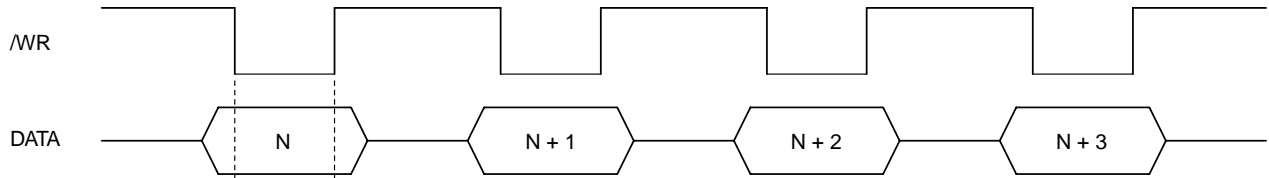

<Internal timing>

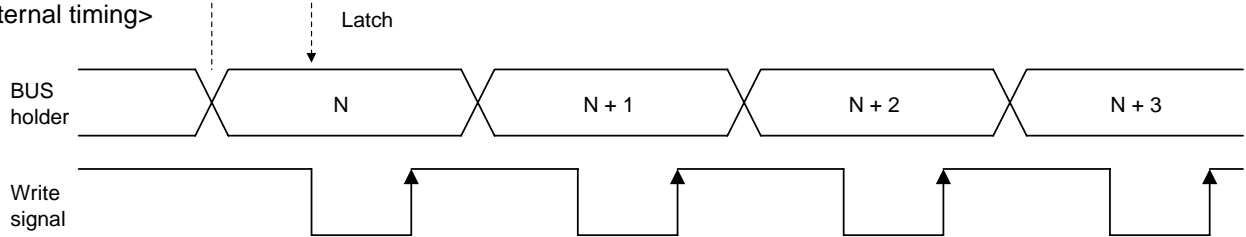

Read (display memory access register (R11))

<CPU>

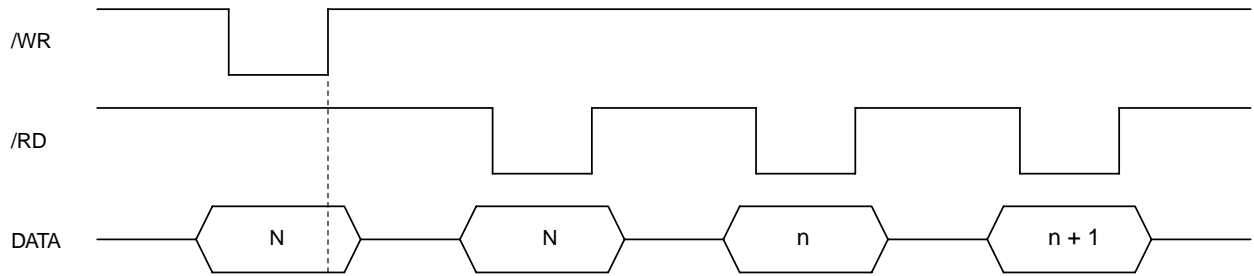

<Internal timing>

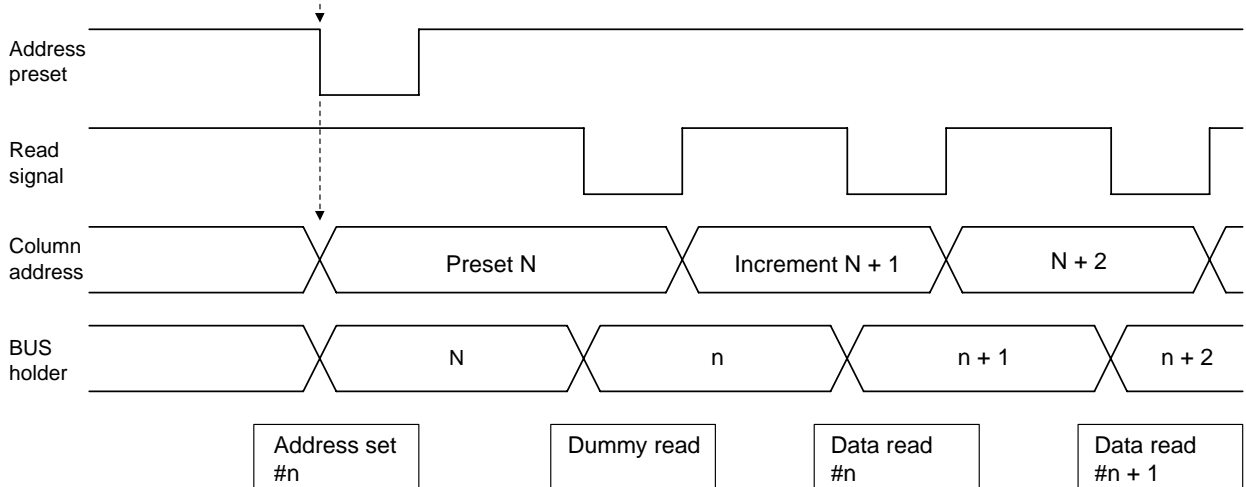
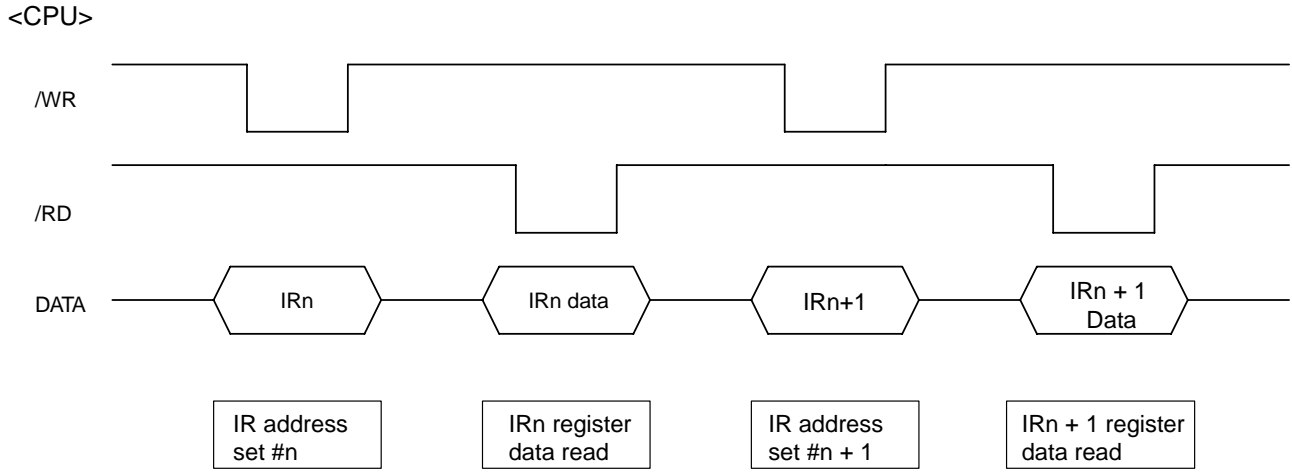

Figure 5-4. Write and Read (2/2)

Read (other than display memory access register)



5.2 Display Data RAM

5.2.1 Display data RAM

This is the RAM that is used to store the display's dot data. The RAM configuration is 256 bits (32 x 8 bits) x 128 bits. Any specified bit can be accessed by selecting the corresponding X address and Y address. The display data D₀ to D₇ sent from the CPU correspond to SEG_x on the LCD display (see Figure 5-5).

The CPU writes data to and reads data from the display RAM via the I/O buffer, and these read/write operations are independent of the signal read operations for the LCD driver. Accordingly, there are no adverse effects (such as flicker) in the LCD display when display data RAM is accessed asynchronously.

Figure 5-5. Display Data RAM

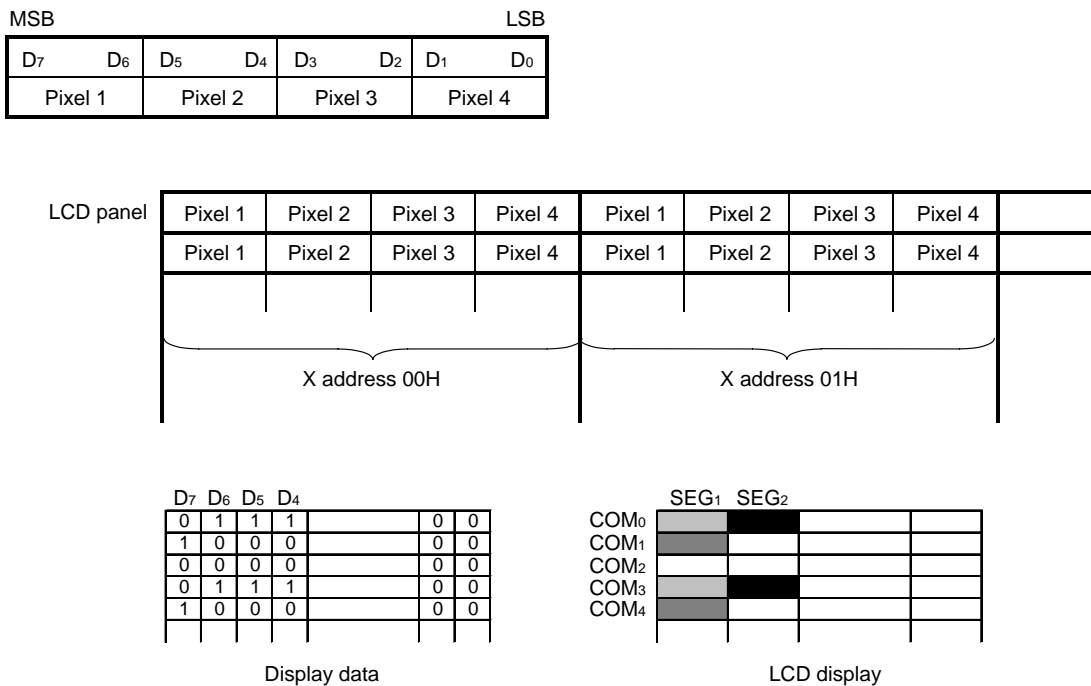

5.2.2 X address circuit

As shown in Figure 5-6, the display data RAM's X address is specified via the X address register (R3). When using X address increment mode (INC = 0: control register 2 (R1)), the specified X address is incremented (by 1) each time a display data read or write operation is executed. The CPU is able to continuously access the display data. The X address is incremented to 1FH, after which the Y address is incremented after each read or write operation and the X address is set back to 00H.

For monochrome (black-and-white) display, the X address is incremented to 0FH, after which the Y address is incremented after each read or write operation and the X address is set back to 00H.

5.2.3 Column address circuit

When displaying the contents of the display data RAM, the column address corresponds to the SEG output, as shown in Figure 5-6. Similarly, the static icon address corresponds to the PSEG output.

As is shown in Tables 5-1 and 5-2, the correspondence between the display RAM's column address and segment output can be inverted using the ADC flag in control register 1 (R0) (segment driver direction selection flag). This reduces the constraints on chip layout when assembling the LCD module.

Table 5-1. Relationship between Column Address and SEG Output

SEG Output		SEG ₁		SEG ₁₂₈	
ADC (D ₁)	0	00H	→	Column address →	7FH
	1	7FH	←	Column address ←	00H

Table 5-2. Relationship between Column Address for Static Icon and PSEG Output

PSEG Output		PSEG ₁		PSEG ₂₀	
ADC (D ₁)	0	00H	→	Column address →	04H
	1	04H	←	Column address ←	00H

5.2.4 Y address circuit

As is shown in Figure 5-4, the Y address register (R4) is used to specify the display data RAM's Y address. When using Y address increment mode (INC = 1: control register 2 (R1)), the specified Y address is incremented (by 1) each time a display data read or write operation is executed. The CPU is able to continuously access the display data. The Y address is incremented to 7FH, after which the X address is incremented after each read or write operation and the Y address is set back to 00H.

5.2.5 Common scan circuit

The common scan circuit sets the scan lines for common signals. The scan direction is set using the COMR flag in control register 1 (R0), as shown in Table 5-3.

For example, when using 1/80 duty, when COMR = 0 the scan direction is COM₁ → COM₈₀ and when COMR = 1, the scan direction is COM₈₀ → COM₁ using the COM₈₀ to COM₁ pins.

Table 5-3. Relationship between Common Scan Circuit and Scan Direction

COMR		COM ₁		COM ₁₂₈
(D ₀)	0	COM ₁	→	COM ₁₂₈
	1	COM ₁₂₈	→	COM ₁

5.2.6 Display start line set

As is shown in Figure 5-6, display start line set specifies the Y address that corresponds to the COM₁ output for displaying the contents of display data RAM. The display start line setting register (R12) is used to specify the top line in the display. The screen can be scrolled, overwritten, etc. A 7-bit display start address is set to the display start line setting register.

5.2.7 Display data latch circuit

The display data latch circuit is used for temporary storage of data that is output to the LCD driver from the display data RAM. The display scan command that sets normal or reverse display mode and the display ON/OFF command control latched data so that there is no effect on the data in the display data RAM.

5.3 Blink/Reverse Display Circuit

The μPD16498 enables blinking display and reverse display in designated parts of the full dot display. A blinking display is achieved by cycling ON/OFF (level 0 when four-level gray scale mode has been selected) at approximately 1 Hz and reverse display is achieved by inverting the display level value.

The area designated for blinking is specified via the blink start/end line address registers (R14 and R15), the blink X address register (R13), and the blink data memory access register (R16).

First, the blinking display's start and end line addresses are selected via the blink start/end line address registers. Next, the blink X address register (R13) and the blink data memory (R16) are used to select the column for the blinking display.

The inversion start/end line address registers (R18 and R19), the inverted X address register (R17), and the inverted data memory access register (R20) are used to select the reverse display area.

First, the inversion start/end line address registers (R18 and R19) are set to select the line addresses where the reverse display will start and end. Next, the inverted X address register (R17) and the inverted data memory access register (R20) are used to select the column for the reverse display. The specified blink/inverted X address is incremented (by 1) with each input of blink/reverse display data.

The blink RAM and inversion RAM, which have a 128 bit (16 x 8 bit) configuration, are used to store data for blinking display and reverse display respectively. To access the desired bit, simply specify the corresponding X address. The blink/reverse data (data bits D0 to D7 sent from the CPU) correspond to SEGx on the LCD display, as shown in Figure 5-7.

After the area and data settings are complete, the BLD bit and IVD bit in the control register 1 (R0) are set to H, at which point the blinking and/or reverse display of data begins. Figure 5-8 illustrates the relationship between the start line address, end line address, blink/reverse data, and LCD display.

Table 5-4. Inversion Manipulation and Display

Original Level	After Inversion
Four-level gray scale display mode	
0, 0	1, 1
0, 1	1, 0
1, 0	0, 1
1, 1	0, 0
B/W display mode	
1	0
0	1

Figure 5-7. Correspondence between Blink/Reverse Data and Segments

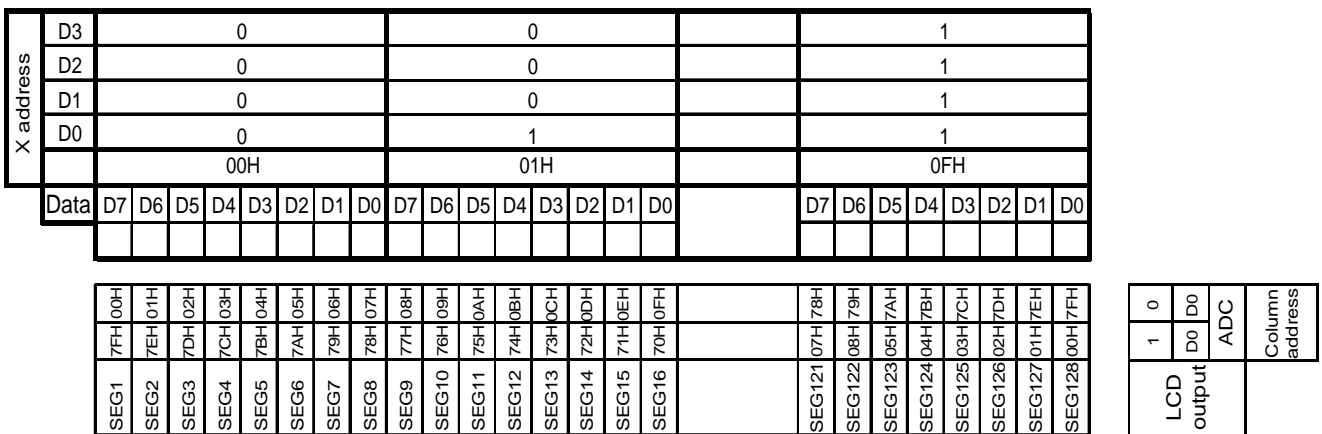
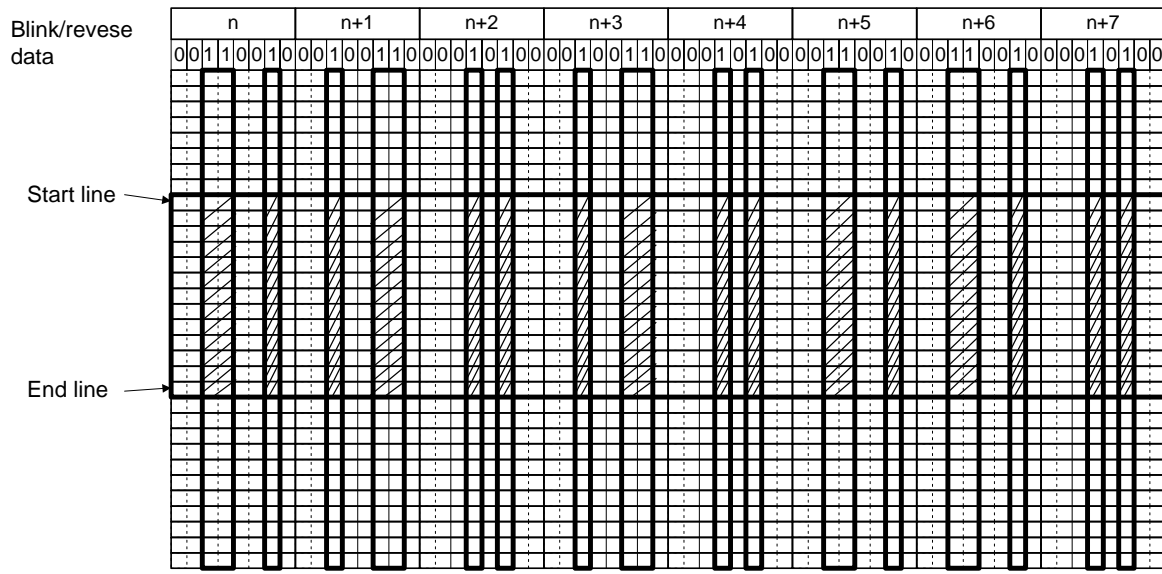
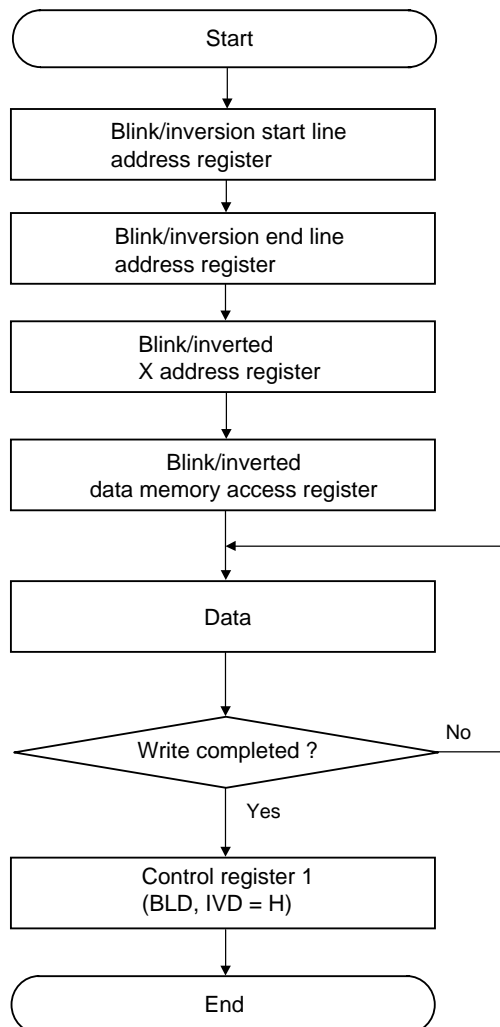

Figure 5-8. Setting Image of Blink/Reverse Display Area



▨ Blinking or reverse display pixels.

Example of sequence for setting blink/reverse display



5.4 Oscillator

The μPD16498 include a CR-type oscillator (R external) for normal and partial display, which generates the display clocks.

The clocks from this oscillator are controlled via the CLS pin and the DTY flag in the control register 2 (R1). The clock configuration for the display can be set to suit the target system.

The functions of this circuit are described below.

- The oscillator for normal and partial display is enabled only when resistors RN and RP have been connected. The DTY flag in the control register 2 (R1) and the CLS pin status are used to switch between the oscillation clocks for normal display and partial display modes.
- The divider divides the external clock that has been input for the normal oscillator and the normal display into a clock for partial display. The external clock that is input for the partial oscillator and partial display is also divided for the partial display.
- The division level is automatically set for the divider based on the relationship between the ON/OFF status of the divider setting pin (CLS pin) and the duty of the specified partial display, as shown in Table 5-5.

Figure 5-9. Oscillator Block

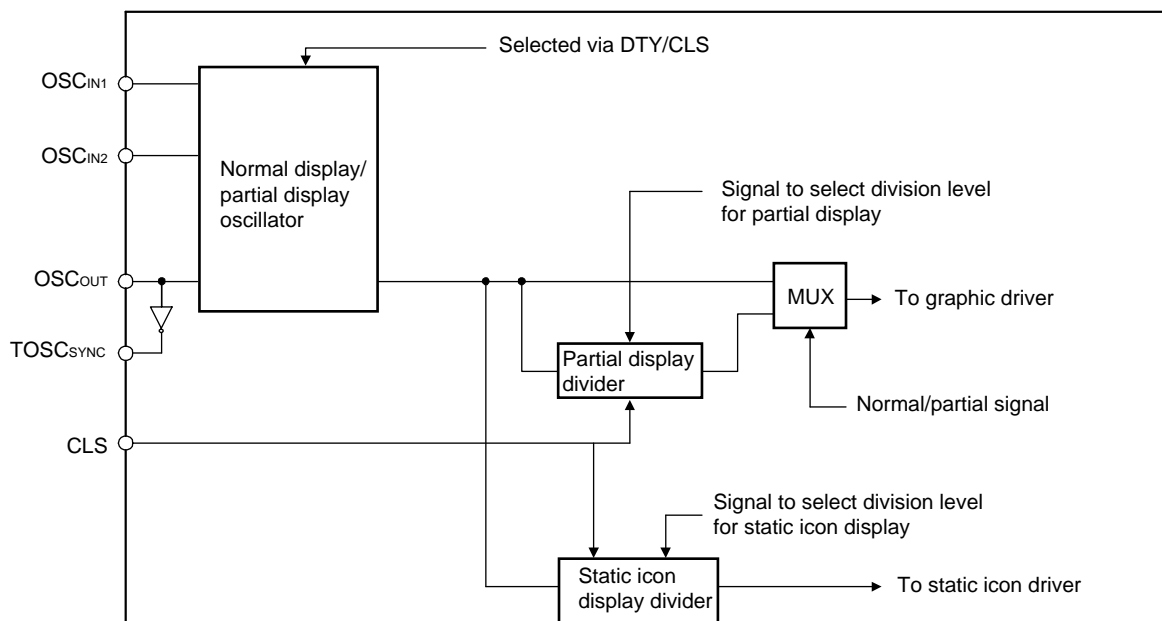

The relationship between the frame frequency (f_{FRAME}), oscillation frequency (f_{OSCIN1}), and setting duty (in normal display mode) is described below.

$$f_{FRAME} = f_{OSCIN1} \div 8 \div N \text{ (in four-level gray scale display mode)}$$

$$f_{FRAME} = f_{OSCIN1} \div 4 \div N \text{ (in B/W display mode)}$$

$$N = 1/N \text{ duty (setting duty)}$$

Table 5-5. Setting of Division Level for Partial Display and Static Icon Display (1/2)

In four-level gray scale display mode (GRAY = L, control register 2 (R1))

Display Mode	Normal Display Duty Ratio	Partial Display Duty Ratio	Division Source OSCIN1 /OSCIN2	Divider ON/OFF CLS	Normal/Partial Select DTY	Partial Division Ratio	Static Icon Division Ratio	Comments		
Four-level gray scale GRAY = L	1/1 to 1/80	1/38	OSCIN1	L(OFF)	L (Normal)	-	1/12	Static icon frame frequency: foscIN1 /12(division ratio) /32		
		1/25		H(ON)						
		1/12								
		1/38								
		1/25								
		1/12								
		1/38	OSCIN2		L(OFF)	H (Partial)	1/1	1/4	Partial frame frequency: foscIN2 /8 /38 ; Static icon frame frequency: foscIN2 /4(division ratio) /32	
		1/25		1/1	Partial frame frequency: foscIN2 /8 /25 ; Static icon frame frequency: foscIN2 /4(division ratio) /32					
		1/12		1/2	Partial frame frequency: foscIN2 /2(division ratio) /8 /12 ; Static icon frame frequency: foscIN2 /4(division ratio) /32					
		1/38		OSCIN1	H(ON)		1/2	1/12	Partial frame frequency: foscIN1 /2(division ratio) /8 /38 ; Static icon frame frequency: foscIN1 /12(division ratio) /32	
		1/25					1/2		Partial frame frequency: foscIN1 /2(division ratio) /8 /25 ; Static icon frame frequency: foscIN1 /12(division ratio) /32	
		1/12					1/4		Partial frame frequency: foscIN1 /4(division ratio) /8 /12 ; Static icon frame frequency: foscIN1 /12(division ratio) /32	
	1/81 to 1/96	1/38	OSCIN1	L(OFF)	L (Normal)	-	-	1/16	Static icon frame frequency: foscIN1 /16(division ratio) /32	
				1/25						H(ON)
				1/12						
				1/38						
				1/25						
				1/12						
		1/38	OSCIN2	L(OFF)	H (Partial)	1/1	1/4	Partial frame frequency: foscIN2 /8 /38 ; Static icon frame frequency: foscIN2 /4(division ratio) /32		
		1/25		1/1		Partial frame frequency: foscIN2 /8 /25 ; Static icon frame frequency: foscIN2 /4(division ratio) /32				
		1/12		1/2		Partial frame frequency: foscIN2 /2(division ratio) /8 /12 ; Static icon frame frequency: foscIN2 /4(division ratio) /32				
		1/38		OSCIN1		H(ON)	1/2	1/16	Partial frame frequency: foscIN1 /2(division ratio) /8 /38 ; Static icon frame frequency: foscIN1 /16(division ratio) /32	
		1/25					1/4		Partial frame frequency: foscIN1 /4(division ratio) /8 /25 ; Static icon frame frequency: foscIN1 /16(division ratio) /32	
		1/12					1/8		Partial frame frequency: foscIN1 /8(division ratio) /8 /12 ; Static icon frame frequency: foscIN1 /16(division ratio) /32	
1/97 to 1/112	1/38	OSCIN1	L(OFF)	L (Normal)	-	-	1/16	Static icon frame frequency: foscIN1 /16(division ratio) /32		
			1/25						H(ON)	
			1/12							
			1/38							
			1/25							
			1/12							
	1/38	OSCIN2	L(OFF)	H (Partial)	1/1	1/4	Partial frame frequency: foscIN2 /8 /38 ; Static icon frame frequency: foscIN2 /4(division ratio) /32			
	1/25		1/1		Partial frame frequency: foscIN2 /8 /25 ; Static icon frame frequency: foscIN2 /4(division ratio) /32					
	1/12		1/2		Partial frame frequency: foscIN2 /2(division ratio) /8 /12 ; Static icon frame frequency: foscIN2 /4(division ratio) /32					
	1/38		OSCIN1		H(ON)	1/2	1/16	Partial frame frequency: foscIN1 /2(division ratio) /8 /38 ; Static icon frame frequency: foscIN1 /16(division ratio) /32		
	1/25					1/4		Partial frame frequency: foscIN1 /4(division ratio) /8 /25 ; Static icon frame frequency: foscIN1 /16(division ratio) /32		
	1/12					1/8		Partial frame frequency: foscIN1 /8(division ratio) /8 /12 ; Static icon frame frequency: foscIN1 /16(division ratio) /32		
1/113 to 1/128	1/38	OSCIN1	L(OFF)	L (Normal)	-	-	1/20	Static icon frame frequency: foscIN1 /20(division ratio) /32		
			1/25						H(ON)	
			1/12							
			1/38							
			1/25							
			1/12							
	1/38	OSCIN2	L(OFF)	H (Partial)	1/1	1/4	Partial frame frequency: foscIN2 /8 /38 ; Static icon frame frequency: foscIN2 /4(division ratio) /32			
	1/25		1/1		Partial frame frequency: foscIN2 /8 /25 ; Static icon frame frequency: foscIN2 /4(division ratio) /32					
	1/12		1/2		Partial frame frequency: foscIN2 /2(division ratio) /8 /12 ; Static icon frame frequency: foscIN2 /4(division ratio) /32					
	1/38		OSCIN1		H(ON)	1/2	1/20	Partial frame frequency: foscIN1 /2(division ratio) /8 /38 ; Static icon frame frequency: foscIN1 /20(division ratio) /32		
	1/25					1/4		Partial frame frequency: foscIN1 /4(division ratio) /8 /25 ; Static icon frame frequency: foscIN1 /20(division ratio) /32		
	1/12					1/8		Partial frame frequency: foscIN1 /8(division ratio) /8 /12 ; Static icon frame frequency: foscIN1 /20(division ratio) /32		

Table 5-5. Setting of Division Level for Partial Display and Static Icon Display (2/2)

In black/white display mode (GRAY = H, control register 2 (R1))

Display Mode	Normal Display Duty Ratio	Partial Display Duty Ratio	Division Source OSC _{IN1} / OSC _{IN2}	Divider ON/OFF CLS	Normal/Partial Select DTY	Partial Division Ratio	Static Icon Division Ratio	Comments		
B/W GRAY = H	1/1 to 1/80	1/38	OSC _{IN1}	L(OFF)	L (Normal)	-	1/6	Static icon frame frequency: f _{OSCIN1} / 6 (division ratio) / 32		
		1/25								
		1/12								
		1/38								
		1/25								
		1/12								
		1/38	OSC _{IN2}	L(OFF)	H (Partial)	1/1	1/2	Partial frame frequency: f _{OSCIN2} / 4 / 38 ; Static icon frame frequency: f _{OSCIN2} / 2 (division ratio) / 32		
		1/25				1/1		Partial frame frequency: f _{OSCIN2} / 4 / 25 ; Static icon frame frequency: f _{OSCIN2} / 2 (division ratio) / 32		
		1/12				1/2		Partial frame frequency: f _{OSCIN2} / 2 (division ratio) / 4 / 12 ; Static icon frame frequency: f _{OSCIN2} / 2 (division ratio) / 32		
		1/38	OSC _{IN1}	H(ON)		1/2	1/6	Partial frame frequency: f _{OSCIN1} / 2 (division ratio) / 4 / 38 ; Static icon frame frequency: f _{OSCIN1} / 6 (division ratio) / 32		
		1/25				1/2		Partial frame frequency: f _{OSCIN1} / 2 (division ratio) / 4 / 25 ; Static icon frame frequency: f _{OSCIN1} / 6 (division ratio) / 32		
		1/12				1/4		Partial frame frequency: f _{OSCIN1} / 4 (division ratio) / 4 / 12 ; Static icon frame frequency: f _{OSCIN1} / 6 (division ratio) / 32		
	1/81 to 1/96	1/38	OSC _{IN1}	L(OFF)	L (Normal)	-	-	1/8	Static icon frame frequency: f _{OSCIN1} / 8 (division ratio) / 32	
										1/25
										1/12
										1/38
										1/25
										1/12
		1/38	OSC _{IN2}	L(OFF)	H (Partial)	1/1	1/2	Partial frame frequency: f _{OSCIN2} / 4 / 38 ; Static icon frame frequency: f _{OSCIN2} / 2 (division ratio) / 32		
		1/25				1/1		Partial frame frequency: f _{OSCIN2} / 4 / 25 ; Static icon frame frequency: f _{OSCIN2} / 2 (division ratio) / 32		
		1/12				1/2		Partial frame frequency: f _{OSCIN2} / 2 (division ratio) / 4 / 12 ; Static icon frame frequency: f _{OSCIN2} / 2 (division ratio) / 32		
		1/38	OSC _{IN1}	H(ON)		1/2	1/8	Partial frame frequency: f _{OSCIN1} / 2 (division ratio) / 4 / 38 ; Static icon frame frequency: f _{OSCIN1} / 8 (division ratio) / 32		
		1/25				1/4		Partial frame frequency: f _{OSCIN1} / 4 (division ratio) / 4 / 25 ; Static icon frame frequency: f _{OSCIN1} / 8 (division ratio) / 32		
		1/12				1/8		Partial frame frequency: f _{OSCIN1} / 8 (division ratio) / 4 / 12 ; Static icon frame frequency: f _{OSCIN1} / 8 (division ratio) / 32		
	1/97 to 1/112	1/38	OSC _{IN1}	L(OFF)	L (Normal)	-	-	1/8	Static icon frame frequency: f _{OSCIN1} / 8 (division ratio) / 32	
										1/25
										1/12
										1/38
										1/25
										1/12
		1/38	OSC _{IN2}	L(OFF)	H (Partial)	1/1	1/2	Partial frame frequency: f _{OSCIN2} / 4 / 38 ; Static icon frame frequency: f _{OSCIN2} / 2 (division ratio) / 32		
		1/25				1/1		Partial frame frequency: f _{OSCIN2} / 4 / 25 ; Static icon frame frequency: f _{OSCIN2} / 2 (division ratio) / 32		
		1/12				1/2		Partial frame frequency: f _{OSCIN2} / 2 (division ratio) / 4 / 12 ; Static icon frame frequency: f _{OSCIN2} / 2 (division ratio) / 32		
		1/38	OSC _{IN1}	H(ON)		1/2	1/8	Partial frame frequency: f _{OSCIN1} / 2 (division ratio) / 4 / 38 ; Static icon frame frequency: f _{OSCIN1} / 8 (division ratio) / 32		
		1/25				1/4		Partial frame frequency: f _{OSCIN1} / 4 (division ratio) / 4 / 25 ; Static icon frame frequency: f _{OSCIN1} / 8 (division ratio) / 32		
		1/12				1/8		Partial frame frequency: f _{OSCIN1} / 8 (division ratio) / 4 / 12 ; Static icon frame frequency: f _{OSCIN1} / 8 (division ratio) / 32		
1/113 to 1/128	1/38	OSC _{IN1}	L(OFF)	L (Normal)	-	-	1/10	Static icon frame frequency: f _{OSCIN1} / 10 (division ratio) / 32		
									1/25	
									1/12	
									1/38	
									1/25	
									1/12	
	1/38	OSC _{IN2}	L(OFF)	H (Partial)	1/1	1/2	Partial frame frequency: f _{OSCIN2} / 4 / 38 ; Static icon frame frequency: f _{OSCIN2} / 2 (division ratio) / 32			
	1/25				1/1		Partial frame frequency: f _{OSCIN2} / 4 / 25 ; Static icon frame frequency: f _{OSCIN2} / 2 (division ratio) / 32			
	1/12				1/2		Partial frame frequency: f _{OSCIN2} / 2 (division ratio) / 4 / 12 ; Static icon frame frequency: f _{OSCIN2} / 2 (division ratio) / 32			
	1/38	OSC _{IN1}	H(ON)		1/2	1/10	Partial frame frequency: f _{OSCIN1} / 2 (division ratio) / 4 / 38 ; Static icon frame frequency: f _{OSCIN1} / 10 (division ratio) / 32			
	1/25				1/4		Partial frame frequency: f _{OSCIN1} / 4 (division ratio) / 4 / 25 ; Static icon frame frequency: f _{OSCIN1} / 10 (division ratio) / 32			
	1/12				1/8		Partial frame frequency: f _{OSCIN1} / 8 (division ratio) / 4 / 12 ; Static icon frame frequency: f _{OSCIN1} / 10 (division ratio) / 32			

Table 5-6 shows the relationship between the CLS pin, resistors RN and RP, and the display clock circuit.

Table 5-6. Relationship between CLS Pin/Resistors and Display Clock Circuit.

RN Connection	RP Connection	CLS	Clock for Normal Display	Clock for Partial Display	Use Example (Figure 5-8)
Connected	Connected	L	Internal oscillator	Internal oscillator	(A)
Connected	Not connected	H	Internal oscillator	Divided from oscillator clock	(B)
Not connected	Connected	L	External clock	Internal oscillator	(C)
Not connected	Not connected	L	External clock	External clock	(D)
Not connected	Not connected	H	External clock	Divided from external clock	(E)

Figure 5-10. Clock Use Examples

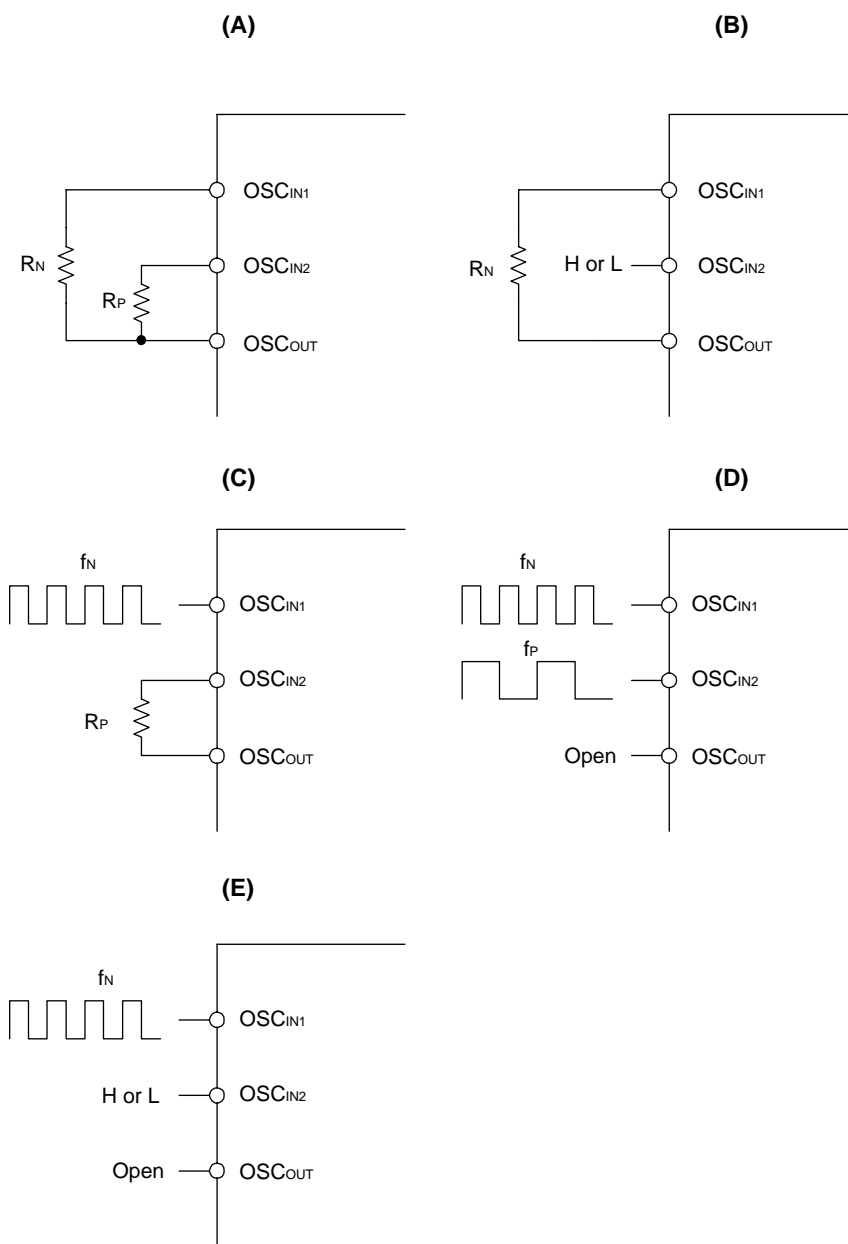

5.5 Display Timing Generator

The display clock generates timing signals for the line address circuit and the display data latch circuit.

Display data is latched into the display data latch circuit in synch with the display clock and is output via segment driver output pins.

Reading of the display data is completely independent of the CPU's accessing of the display data RAM. Consequently, there are no adverse effects (such as flicker) on the LCD panel even when the display data RAM is accessed asynchronously in relation to the LCD contents.

The internal common timing is generated from the display clock. As shown in Figure 5-11, a driver waveform based on the frame AC drive method is generated for the LCD driver.

Figure 5-11. Driver Waveform Based on Frame AC Drive Method

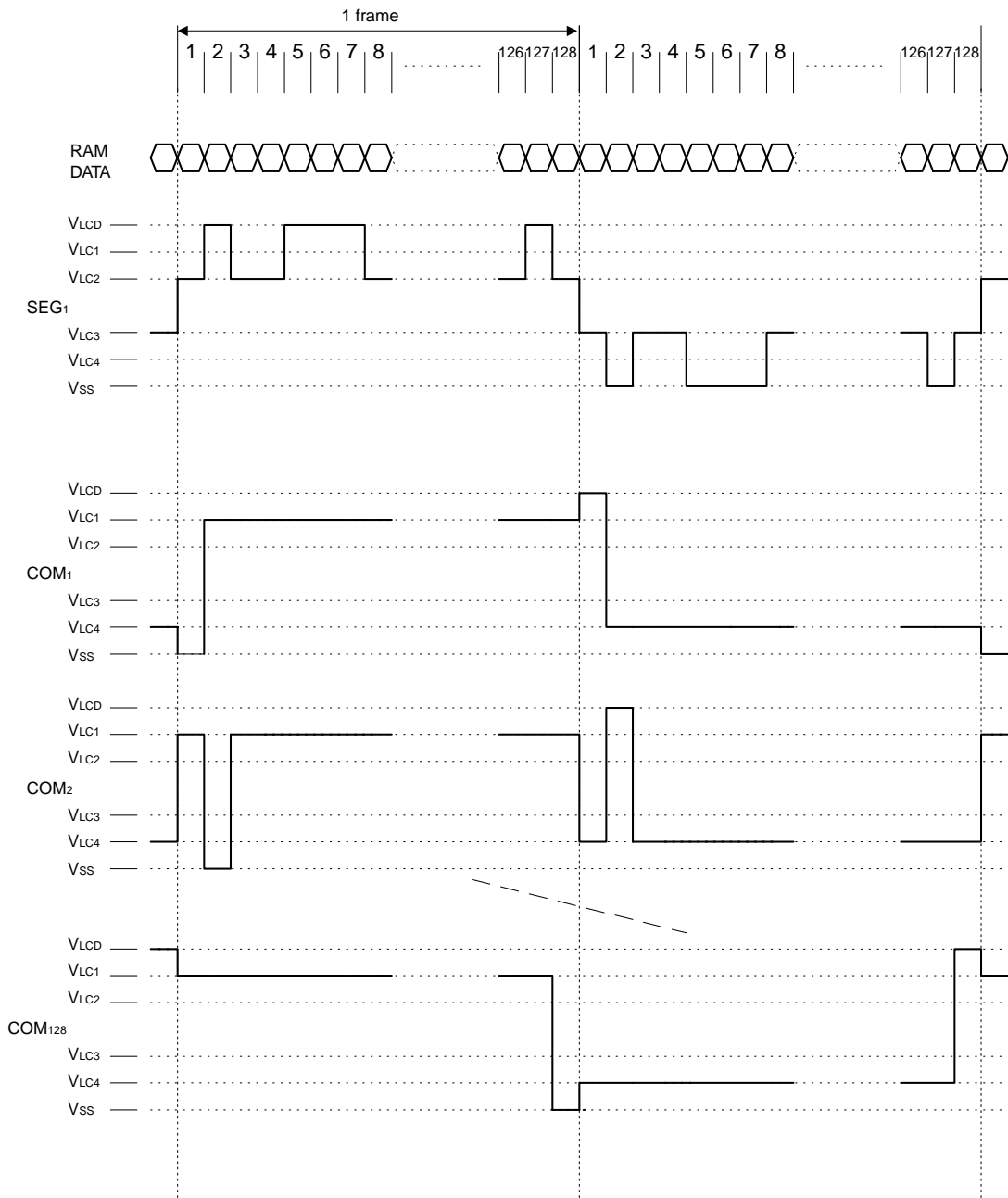

5.6 Power Supply Circuit

The power supply circuit supplies the voltage needed to drive the LCD. It includes a booster, voltage regulator, and voltage follower.

In the power supply circuit, the power system control register 1 (R32) is used to control the ON/OFF status of the power supply circuit's booster, voltage regulator (also called V regulator), and voltage follower (V/F). This makes it possible to jointly use an external power supply together with certain functions of the on-chip power supply. Table 5-7 shows the function that controls the 3-bit data in the power system control register 1 (R32) and Table 5-8 shows a reference chart of combinations.

Table 5-7. Control Values of Bits in Power System Control 1

Item		Status	
		1	0
OP2	Booster control bit	ON	OFF
OP1	Voltage regulator (V regulator) control bit	ON	OFF
OP0	Voltage follower (V/F) control bit	ON	OFF

Table 5-8. Reference Chart of Combinations

Use Status	OP2	OP1	OP0	Booster	V Regulator	V/F	External Power Supply Input	Boost-Related System Pins ^{Note}
<1> Use on-chip power supply	1	1	1	enable	enable	enable	V _{DD2}	Used
<2> Use V regulator and V/F only	0	1	1	disable	enable	enable	V _{OUT}	Not connected
<3> Use V/F only	0	0	1	disable	disable	enable	V _{OUT} , AMP _{OUT}	Not connected
<4> Use external power supply only	0	0	0	disable	disable	disable	V _{OUT} , V _{LCD} to V _{LC4}	Not connected

Note The boost-related system pins are indicated as pins C1⁺, C1⁻ to C9⁺, C9⁻, and C1A.

5.6.1 Booster

A booster that boosts the LCD driving voltage by 2 to 9 times is incorporated in the power supply circuit. Since the booster uses signals from the on-chip oscillator, either the oscillator must be operating or a display clock must be input from an external source.

The booster uses pins C1⁺, C1⁻ to C9⁺, C9⁻ for normal boost and pins C1A and V_{DD2} for boost regulation. The wire impedance should be kept as low as possible. The number of boost levels is set using the FBS2, FBS1, and FBS0 flags in power system control 3 (R34), as shown in Table 5-9.

Caution If a capacitor is connected to a boost-related system pin that is not for one of these set boost levels, current consumption may increase. Therefore, do not connect any capacitors beyond the number of set boost levels. This also applies for the C1A pin, used to regulate the boost levels.

Figure 5-12 describes the connection method for boost levels and capacitors.

The partial booster is settings are made using the BST1 and BST0 flags in the power system control 3 (R34), as shown in Table 5-10.

Figure 5-12. Connection Method for Boost Levels and Capacitors

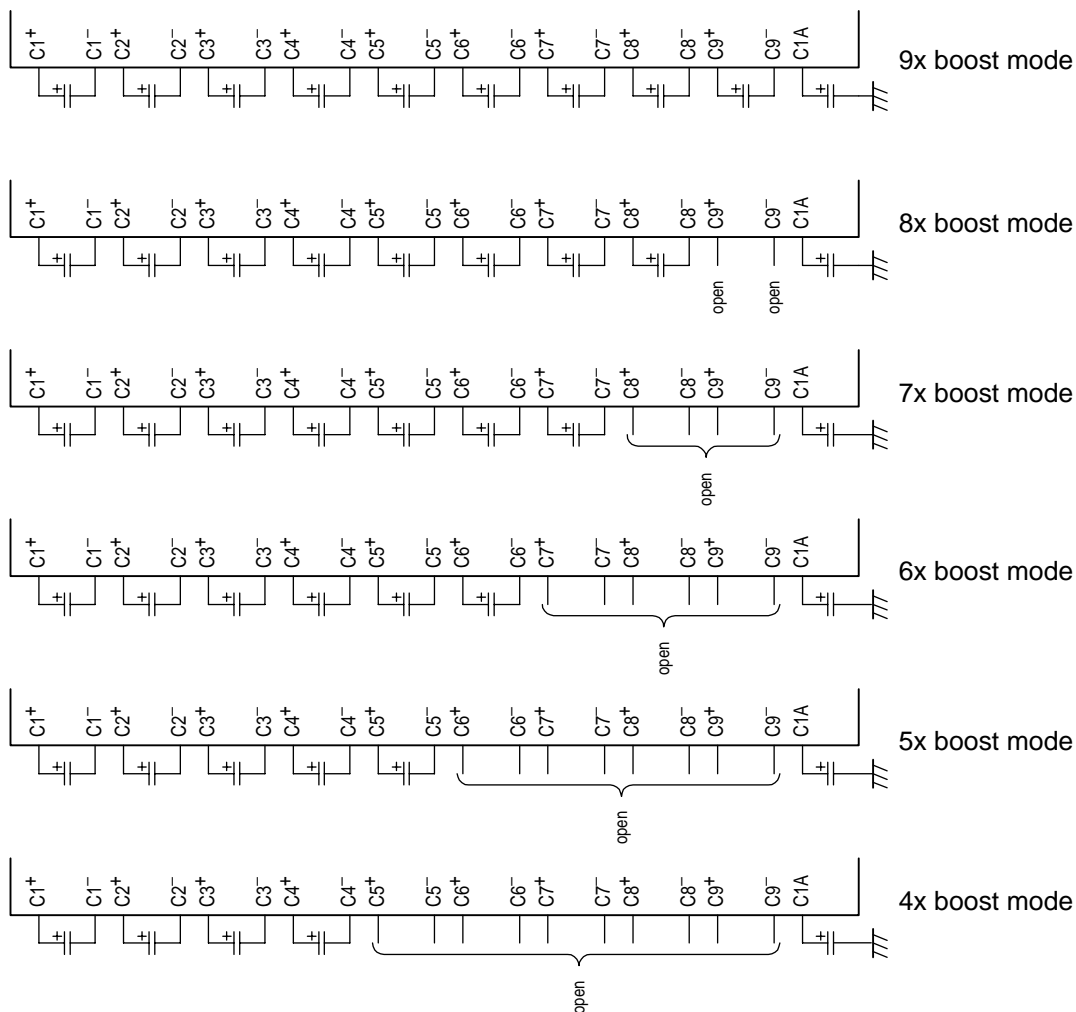

Table 5-9. Boost Level Settings for Normal Display's Booster

FBS2	FBS1	FBS0	Boost Level
0	0	0	4x
0	0	1	5x
0	1	0	6x
0	1	1	7x
1	0	0	8x
1	0	1	9x
1	1	0	Prohibited
1	1	1	Prohibited

Table 5-10. Boost Level Settings for Partial Display's Booster

BST1	BST0	Boost Level
0	0	2x
0	1	3x
1	0	4x
1	1	Prohibited

5.6.2 Voltage regulator

The boost voltage from V_{OUT} is supplied to the voltage regulator and output as the LCD drive voltage V_{LCD} .

Since the μPD16498 has a 256-step electronic volume function and an on-chip resistor for V_{LCD} voltage regulation, a small number of components can be used to configure a highly accurate voltage regulator.

(1) When using an on-chip resistor for V_{LCD} voltage regulation

The on-chip resistor for V_{LCD} voltage regulation and the electronic volume function can be used to regulate the contrast of the LCD contents by controlling the LCD drive voltage V_{LCD} using commands only. In such cases, no external resistor is needed.

If $V_{LCD} < V_{OUT}$, then the value for V_{LCD} can be determined from the following equation.

Example Equation $V_{LCD} < V_{OUT}$

$$V_{LCD} = \left(1 + \frac{R_b}{R_a}\right) V_{EV}$$

$$V_{LCD} = \left(1 + \frac{R_b}{R_a}\right) \left(1 - \frac{\alpha}{384}\right) V_{REG}$$

Remark $V_{EV} = \left(1 - \frac{\alpha}{384}\right) V_{REG}$

Figure 5-13. When Using On-Chip Resistor for V_{LCD} Voltage Regulation

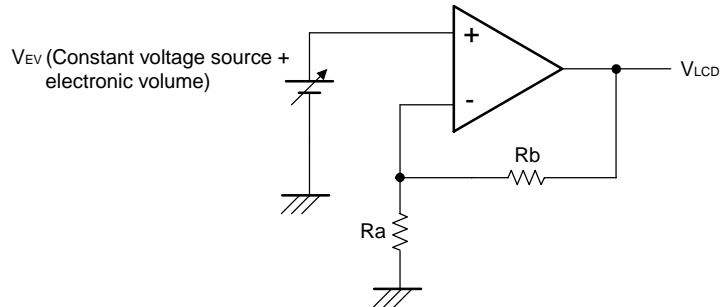

V_{REG} is the IC's on-chip constant voltage source, for which three types of temperature characteristic curves are available. These temperature characteristic curves can be adjusted via settings in the power system control register 1 (R32) (TSC1, TCS0), as shown in Table 5-11.

Table 5-11 shows the V_{REG} voltage when $T_A = 25^\circ\text{C}$.

Table 5-11. V_{REG} Voltage When $T_A = 25^\circ\text{C}$

Status	TCS1	TCS0	Temperature Curve (%/°C)	V_{REG} (TYP.) (V)
Internal power supply	0	0	-0.06	1.04
	0	1	-0.08	0.98
	1	0	-0.09	0.93
	1	1	-0.12	0.85

α is the electronic volume register (R35) value. Any of 256 statuses can be set as the fetched status for α corresponding to the data set to the 8-bit electronic control register. α values based on settings in the electronic volume register (R35: normal display mode) and the partial electronic volume register (R36: partial display mode) are listed in Table 5-12.

Table 5-12. α Values Based on Settings in Electronic Volume Register

Register								α
EV7	EV6	EV5	EV4	EV3	EV2	EV1	EV0	
PEV7	PEV6	PEV5	PEV4	PEV3	PEV2	PEV1	PEV0	
0	0	0	0	0	0	0	0	384
0	0	0	0	0	0	0	1	254
0	0	0	0	0	0	1	0	253
0	0	0	0	0	0	1	1	252
				:				:
1	1	1	1	1	1	0	1	2
1	1	1	1	1	1	1	0	1
1	1	1	1	1	1	1	1	0

Rb/Ra is an on-chip resistance factor used for the VLCD voltage regulator. This factor can be controlled at eight levels based on settings in power control register 2 (R33) (VRR2, VRR1, VRR0: normal display mode and PVR2, PVR1, PVR0: partial display mode). Reference voltage values (1 + Rb/Ra) are determined based on 4-bit data set to VLCD's on-chip resistance factor register, as shown in Table 5-13.

Table 5-13. Determination of Reference Voltage Values Based on Settings of On-Chip Resistor for VLCD Voltage Regulation

Register			1+Rb/Ra
VRR2	VRR1	VRR0	
PVR2	PVR1	PVR0	
0	0	0	5
0	0	1	8
0	1	0	12
0	1	1	13
1	0	0	16
1	0	1	19
1	1	0	21
1	1	1	24

(2) When using an external resistor (instead of using the on-chip resistor for V_{LCD} voltage regulation)

Instead of using only the on-chip resistor setting for V_{LCD} voltage regulation (IRS = L), resistors (Ra', Rb' and Rc') can be added between V_{SS} and V_R, between AMP_{OUTP} and AMP_{OUT}, and between V_R and AMP_{OUT} to set the LCD drive voltage V_{LCD}. In such cases, the electronic volume function can be used to control the LCD drive voltage V_{LCD} and to regulate the contrast of the LCD contents via commands.

In addition, the μPD16498 enable selection between two display values (for normal display and partial display).

The value is set using an external division resistor and is automatically selected by the DTY flag in the control register 2 (R1).

The V_{LCD} value can be determined using **Example 1** (DTY = 0) and **Example 2** (DTY = 1) if it is within the range of V_{LCD} < V_{OUT}.

Example 1. DTY = 0, normal display mode

$$V_{LCD} = \left(1 + \frac{R_{b'}}{R_{a'}}\right) V_{EV}$$

$$V_{LCD} = \left(1 + \frac{R_{b'}}{R_{a'}}\right) \left(1 - \frac{\alpha}{384}\right) V_{REG}$$

Remark $V_{EV} = \left(1 - \frac{\alpha}{384}\right) V_{REG}$

Example 2. DTY = 1, partial display mode

$$V_{LCD} = \left(1 + \frac{R_{b'} \times R_c}{R_{a'}(R_{b'} + R_c)}\right) V_{EV}$$

$$V_{LCD} = \left(1 + \frac{R_{b'} \times R_c}{R_{a'}(R_{b'} + R_c)}\right) \left(1 - \frac{\alpha}{384}\right) V_{REG}$$

Remark $V_{EV} = \left(1 - \frac{\alpha}{384}\right) V_{REG}$

Figure 5-14. When Using External Resistor

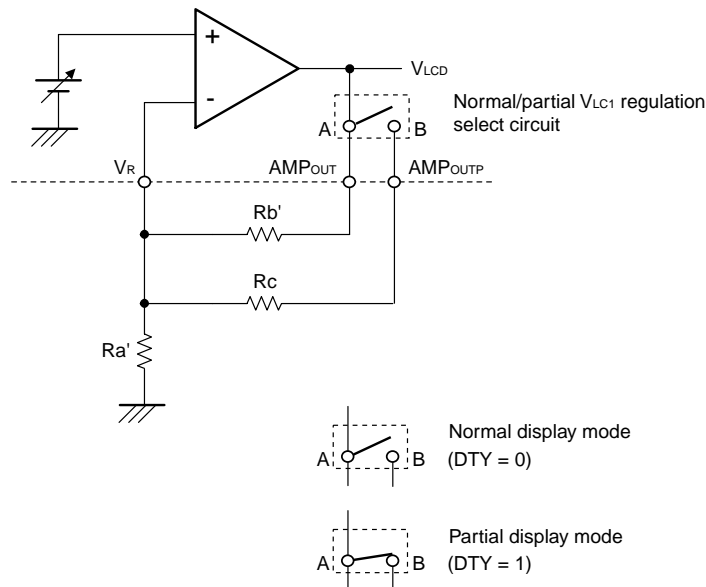

5.6.3 Use of op amp for level power supply control

Although the μPD16498 includes a circuit designed for low power consumption (HPM1, HPM0 = 0, 0), display quality problems may occur when a large-load LCD panel is used. In such cases, the display quality and power consumption level can be improved by setting. The HPM1 and HPM0 flags in the power system control register 1(R32) to "0, 1" to "1, 1" to switch to the op amp driver capacity for mode settings shown in Table 5-14. Check the actual display quality before deciding which mode to set.

If setting high power mode still does not sufficiently improve the display quality, the LCD drive voltage must be provided from an external power source.

Table 5-14. Op Amp Mode Setting

HPM1	HPM0	Mode Setting
0	0	Normal mode
0	1	Low power mode
1	0	High power mode
1	1	For power ON mode

5.6.4 Application examples of power supply circuits

Figures 5-15 to 5-19 show application examples of power supply circuits.

Figure 5-15. IRS = H, [OP2, OP1, OP0] = [1, 1, 1]

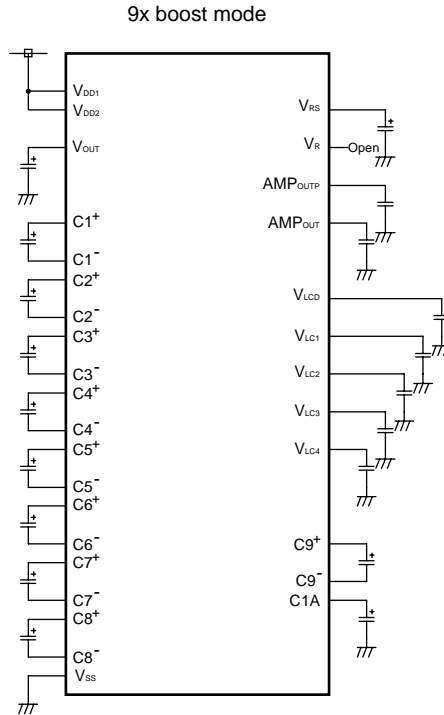

Figure 5-16. IRS = L, [OP2, OP1, OP0] = [1, 1, 1]

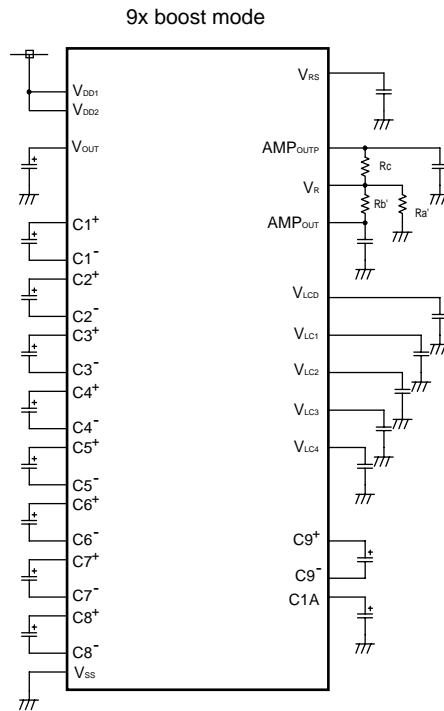

Figure 5-17. IRS = H, [OP2, OP1, OP0] = [0, 1, 1]

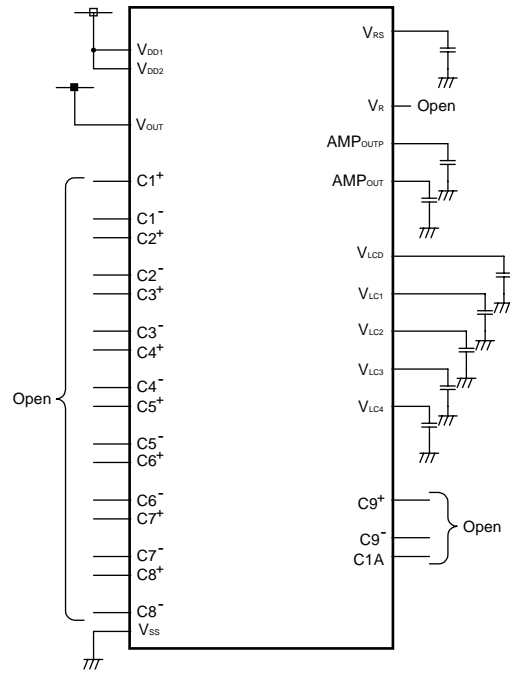

Figure 5-18. IRS = L, [OP2, OP1, OP0] = [0, 0, 1]

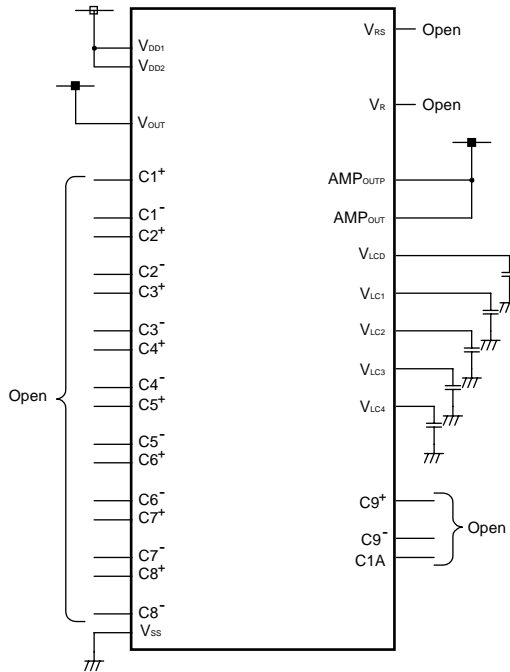
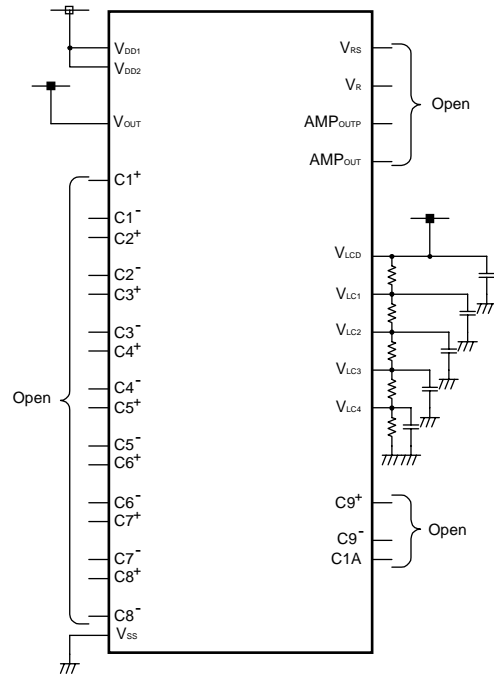

Figure 5-19. IRS = L, [OP2, OP1, OP0] = [0, 0, 0]



5.7 LCD Display Drivers

μPD16498 includes both a full dot driver and a static driver icon driver. The full dot driver has a 33-level gray-scale palette (eight levels of pulse width modulation plus four-frame rate control), from which four levels of gray scale can be selected and registered as the IC's output gray-scale palette. The icon driver has a gray-scale palette with 32-level pulse width modulation, from which four levels of gray scale can be selected and registered for use as the IC's output gray-scale palette (refer to **6.23 Gray scale registers 1 to 4 (R23 to R26)**).

5.7.1 Full-dot pulse width modulation

The μPD16498's pulse width modulator divides the normal LCD display signal's segment pulse width by eight and outputs in synchron with the dot output timing based on the ratio (1/8 to 8/8 pulses) for the gray-scale palette that has been selected via a command.

Figure 5-20. Full-Dot Pulse Width Modulation

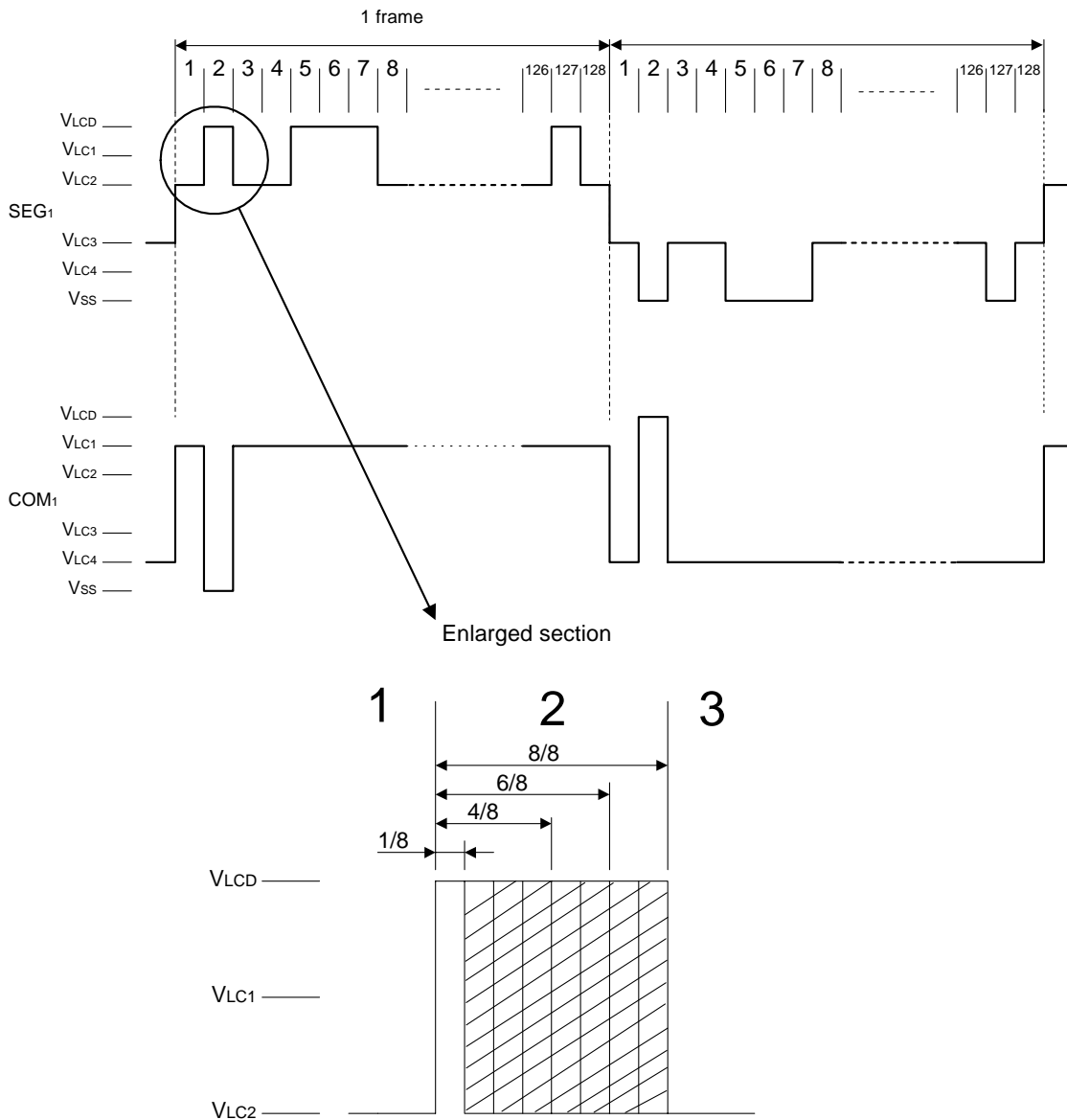

Caution There is no pulse width modulation for common outputs.

The output pulses are output as odd-numbered lines/even-numbered lines or as even-numbered lines/odd-numbered lines, as shown in Figure 5-21. The pulse rising edge and falling edge combinations for each frame are listed in Table 5-15.

Figure 5-21. Example of Pulse Width Modulated Output

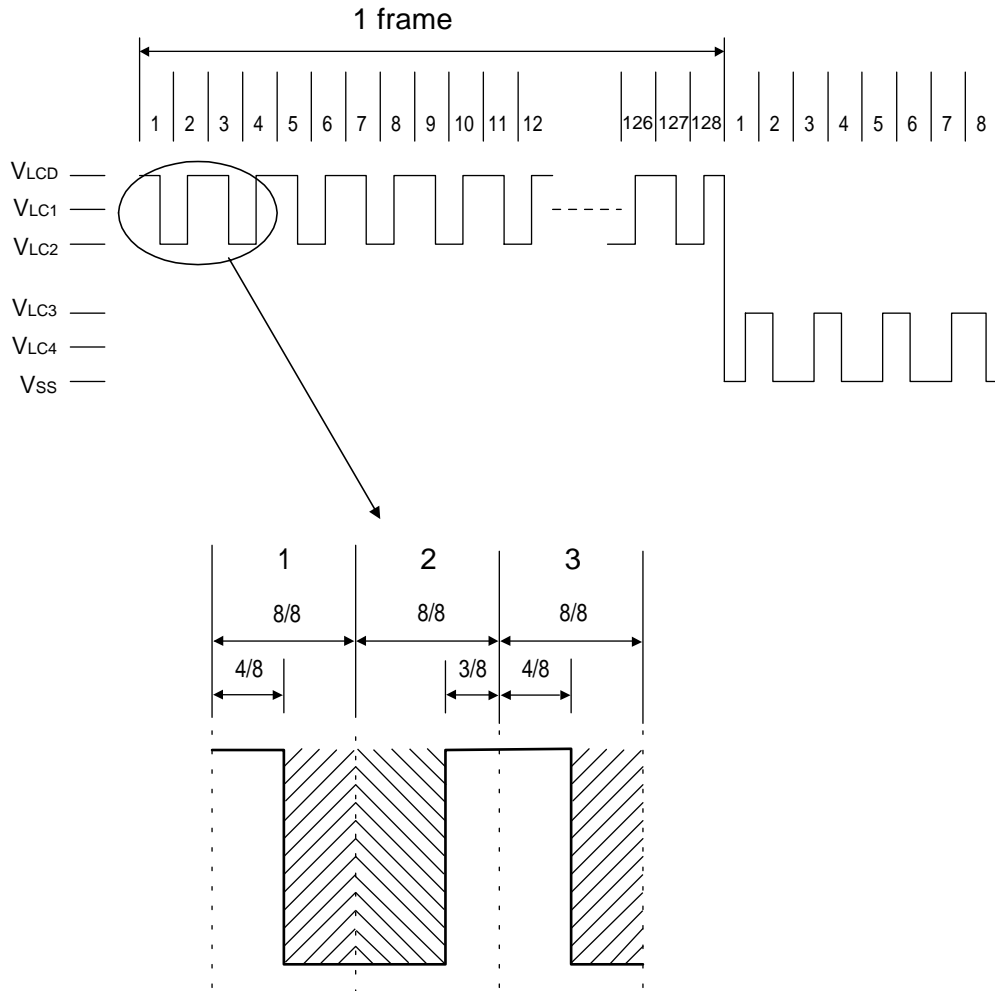

Table 5-15. Example of Pulse Width Modulated Output (1/3)

Gray-scale level	COM	1, 2 Frames		3, 4 Frames		5, 6 Frames		7, 8 Frames	
		SEG Odd Numbered	SEG Even Numbered	SEG Odd Numbered	SEG Even Numbered	SEG Odd Numbered	SEG Even Numbered	SEG Odd Numbered	SEG Even Numbered
0	4n+1	0	0	0	0	0	0	0	0
	4n+2	0	0	0	0	0	0	0	0
	4n+3	0	0	0	0	0	0	0	0
	4n+4	0	0	0	0	0	0	0	0
1	4n+1	↑1	↓1	0	0	0	0	0	0
	4n+2	0	0	0	0	↓1	↑1	0	0
	4n+3	0	0	0	0	0	0	↓1	↑1
	4n+4	0	0	↑1	↓1	0	0	0	0
2	4n+1	↑1	↓1	0	0	↑1	↓1	0	0
	4n+2	↓1	↑1	0	0	↓1	↑1	0	0
	4n+3	0	0	↓1	↑1	0	0	↓1	↑1
	4n+4	0	0	↑1	↓1	0	0	↑1	↓1
3	4n+1	↑1	↓1	↓1	↑1	↑1	↓1	0	0
	4n+2	↓1	↑1	0	0	↓1	↑1	↑1	↓1
	4n+3	↑1	↓1	↓1	↑1	0	0	↓1	↑1
	4n+4	0	0	↑1	↓1	↓1	↑1	↑1	↓1
4	4n+1	↑1	↓1	↓1	↑1	↑1	↓1	↓1	↑1
	4n+2	↓1	↑1	↑1	↓1	↓1	↑1	↑1	↓1
	4n+3	↑1	↓1	↓1	↑1	↑1	↓1	↓1	↑1
	4n+4	↓1	↑1	↑1	↓1	↓1	↑1	↑1	↓1
5	4n+1	↑2	↓2	↓1	↑1	↑1	↓1	↓1	↑1
	4n+2	↓1	↑1	↑1	↓1	↓2	↑2	↑1	↓1
	4n+3	↑1	↓1	↓1	↑1	↑1	↓1	↓2	↑2
	4n+4	↓1	↑1	↑2	↓2	↓1	↑1	↑1	↓1
6	4n+1	↑2	↓2	↓1	↑1	↑2	↓2	↓1	↑1
	4n+2	↓2	↑2	↑1	↓1	↓2	↑2	↑1	↓1
	4n+3	↑1	↓1	↓2	↑2	↑1	↓1	↓2	↑2
	4n+4	↓1	↑1	↑2	↓2	↓1	↑1	↑2	↓2
7	4n+1	↑2	↓2	↓2	↑2	↑2	↓2	↓1	↑1
	4n+2	↓2	↑2	↑1	↓1	↓2	↑2	↑2	↓2
	4n+3	↑2	↓2	↓2	↑2	↑1	↓1	↓2	↑2
	4n+4	↓1	↑1	↑2	↓2	↓2	↑2	↑2	↓2
8	4n+1	↑2	↓2	↓2	↑2	↑2	↓2	↓2	↑2
	4n+2	↓2	↑2	↑2	↓2	↓2	↑2	↑2	↓2
	4n+3	↑2	↓2	↓2	↑2	↑2	↓2	↓2	↑2
	4n+4	↓2	↑2	↑2	↓2	↓2	↑2	↑2	↓2
9	4n+1	↑3	↓3	↓2	↑2	↑2	↓2	↓2	↑2
	4n+2	↓2	↑2	↑2	↓2	↓3	↑3	↑2	↓2
	4n+3	↑2	↓2	↓2	↑2	↑2	↓2	↓3	↑3
	4n+4	↓2	↑2	↑3	↓3	↓2	↑2	↑2	↓2
10	4n+1	↑3	↓3	↓2	↑2	↑3	↓3	↓2	↑2
	4n+2	↓3	↑3	↑2	↓2	↓3	↑3	↑2	↓2
	4n+3	↑2	↓2	↓3	↑3	↑2	↓2	↓3	↑3
	4n+4	↓2	↑2	↑3	↓3	↓2	↑2	↑3	↓3

- Remarks 1. n: Integer from 0 to 31.
 2. ↑A: Rising edge of pulse during line A output.
 3. ↓A: Rising edge of pulse at start of line A output.
 4. A: PWM pulse width (A/8)

Table 5-15. Example of Pulse Width Modulated Output (2/3)

Gray-scale level	COM	1, 2 Frames		3, 4 Frames		5, 6 Frames		7, 8 Frames	
		SEG Odd Numbered	SEG Even Numbered	SEG Odd Numbered	SEG Even Numbered	SEG Odd Numbered	SEG Even Numbered	SEG Odd Numbered	SEG Even Numbered
11	4n+1	↑3	↓3	↓3	↑3	↑3	↓3	↓2	↑2
	4n+2	↓3	↑3	↑2	↓2	↓3	↑3	↑3	↓3
	4n+3	↑3	↓3	↓3	↑3	↑2	↓2	↓3	↑3
	4n+4	↓2	↑2	↑3	↓3	↓3	↑3	↑3	↓3
12	4n+1	↑3	↓3	↓3	↑3	↑3	↓3	↓3	↑3
	4n+2	↓3	↑3	↑3	↓3	↓3	↑3	↑3	↓3
	4n+3	↑3	↓3	↓3	↑3	↑3	↓3	↓3	↑3
	4n+4	↓3	↑3	↑3	↓3	↓3	↑3	↑3	↓3
13	4n+1	↑4	↓4	↓3	↑3	↑3	↓3	↓3	↑3
	4n+2	↓3	↑3	↑3	↓3	↓4	↑4	↑3	↓3
	4n+3	↑3	↓3	↓3	↑3	↑3	↓3	↓4	↑4
	4n+4	↓3	↑3	↑4	↓4	↓3	↑3	↑3	↓3
14	4n+1	↑4	↓4	↓3	↑3	↑4	↓4	↓3	↑3
	4n+2	↓4	↑4	↑3	↓3	↓4	↑4	↑3	↓3
	4n+3	↑3	↓3	↓4	↑4	↑3	↓3	↓4	↑4
	4n+4	↓3	↑3	↑4	↓4	↓3	↑3	↑4	↓4
15	4n+1	↑4	↓4	↓4	↑4	↑4	↓4	↓3	↑3
	4n+2	↓4	↑4	↑3	↓3	↓4	↑4	↑4	↓4
	4n+3	↑4	↓4	↓4	↑4	↑3	↓3	↓4	↑4
	4n+4	↓3	↑3	↑4	↓4	↓4	↑4	↑4	↓4
16	4n+1	↑4	↓4	↓4	↑4	↑4	↓4	↓4	↑4
	4n+2	↓4	↑4	↑4	↓4	↓4	↑4	↑4	↓4
	4n+3	↑4	↓4	↓4	↑4	↑4	↓4	↓4	↑4
	4n+4	↓4	↑4	↑4	↓4	↓4	↑4	↑4	↓4
17	4n+1	↑5	↓5	↓4	↑4	↑4	↓4	↓4	↑4
	4n+2	↓4	↑4	↑4	↓4	↓5	↑5	↑4	↓4
	4n+3	↑4	↓4	↓4	↑4	↑4	↓4	↓5	↑5
	4n+4	↓4	↑4	↑5	↓5	↓4	↑4	↑4	↓4
18	4n+1	↑5	↓5	↓4	↑4	↑5	↓5	↓4	↑4
	4n+2	↓5	↑5	↑4	↓4	↓5	↑5	↑4	↓4
	4n+3	↑4	↓4	↓5	↑5	↑4	↓4	↓5	↑5
	4n+4	↓4	↑4	↑5	↓5	↓4	↑4	↑5	↓5
19	4n+1	↑5	↓5	↓5	↑5	↑5	↓5	↓4	↑4
	4n+2	↓5	↑5	↑4	↓4	↓5	↑5	↑5	↓5
	4n+3	↑5	↓5	↓5	↑5	↑4	↓4	↓5	↑5
	4n+4	↓4	↑4	↑5	↓5	↓5	↑5	↑5	↓5
20	4n+1	↑5	↓5	↓5	↑5	↑5	↓5	↓5	↑5
	4n+2	↓5	↑5	↑5	↓5	↓5	↑5	↑5	↓5
	4n+3	↑5	↓5	↓5	↑5	↑5	↓5	↓5	↑5
	4n+4	↓5	↑5	↑5	↓5	↓5	↑5	↑5	↓5
21	4n+1	↑6	↓6	↓5	↑5	↑5	↓5	↓5	↑5
	4n+2	↓5	↑5	↑5	↓5	↓6	↑6	↑5	↓5
	4n+3	↑5	↓5	↓5	↑5	↑5	↓5	↓6	↑6
	4n+4	↓5	↑5	↑6	↓6	↓5	↑5	↑5	↓5

- Remarks
1. n: Integer from 0 to 31.
 2. ↑A: Rising edge of pulse during line A output.
 3. ↓A: Rising edge of pulse at start of line A output.
 4. A: PWM pulse width (A/8)

Table 5-15. Example of Pulse Width Modulated Output (3/3)

Gray-scale level	COM	1, 2 Frames		3, 4 Frames		5, 6 Frames		7, 8 Frames	
		SEG Odd Numbered	SEG Even Numbered	SEG Odd Numbered	SEG Even Numbered	SEG Odd Numbered	SEG Even Numbered	SEG Odd Numbered	SEG Even Numbered
22	4n+1	↑6	↓6	↓5	↑5	↑6	↓6	↓5	↑5
	4n+2	↓6	↑6	↑5	↓5	↓6	↑6	↑5	↓5
	4n+3	↑5	↓5	↓6	↑6	↑5	↓5	↓6	↑6
	4n+4	↓5	↑5	↑6	↓6	↓5	↑5	↑6	↓6
23	4n+1	↑6	↓6	↓6	↑6	↑6	↓6	↓5	↑5
	4n+2	↓6	↑6	↑5	↓5	↓6	↑6	↑6	↓6
	4n+3	↑6	↓6	↓6	↑6	↑5	↓5	↓6	↑6
	4n+4	↓5	↑5	↑6	↓6	↓6	↑6	↑6	↓6
24	4n+1	↑6	↓6	↓6	↑6	↑6	↓6	↓6	↑6
	4n+2	↓6	↑6	↑6	↓6	↓6	↑6	↑6	↓6
	4n+3	↑6	↓6	↓6	↑6	↑6	↓6	↓6	↑6
	4n+4	↓6	↑6	↑6	↓6	↓6	↑6	↑6	↓6
25	4n+1	↑7	↓7	↓6	↑6	↑6	↓6	↓6	↑6
	4n+2	↓6	↑6	↑6	↓6	↓7	↑7	↑6	↓6
	4n+3	↑6	↓6	↓6	↑6	↑6	↓6	↓7	↑7
	4n+4	↓6	↑6	↑7	↓7	↓6	↑6	↑6	↓6
26	4n+1	↑7	↓7	↓6	↑6	↑7	↓7	↓6	↑6
	4n+2	↓7	↑7	↑6	↓6	↓7	↑7	↑6	↓6
	4n+3	↑6	↓6	↓7	↑7	↑6	↓6	↓7	↑7
	4n+4	↓6	↑6	↑7	↓7	↓6	↑6	↑7	↓7
27	4n+1	↑7	↓7	↓7	↑7	↑7	↓7	↓6	↑6
	4n+2	↓7	↑7	↑6	↓6	↓7	↑7	↑7	↓7
	4n+3	↑7	↓7	↓7	↑7	↑6	↓6	↓7	↑7
	4n+4	↓6	↑6	↑7	↓7	↓7	↑7	↑7	↓7
28	4n+1	↑7	↓7	↓7	↑7	↑7	↓7	↓7	↑7
	4n+2	↓7	↑7	↑7	↓7	↓7	↑7	↑7	↓7
	4n+3	↑7	↓7	↓7	↑7	↑7	↓7	↓7	↑7
	4n+4	↓7	↑7	↑7	↓7	↓7	↑7	↑7	↓7
29	4n+1	8	8	↓7	↑7	↑7	↓7	↓7	↑7
	4n+2	↓7	↑7	↑7	↓7	8	8	↑7	↓7
	4n+3	↑7	↓7	↓7	↑7	↑7	↓7	8	8
	4n+4	↓7	↑7	8	8	↓7	↑7	↑7	↓7
30	4n+1	8	8	↓7	↑7	8	8	↓7	↑7
	4n+2	8	8	↑7	↓7	8	8	↑7	↓7
	4n+3	↑7	↓7	8	8	↑7	↓7	8	8
	4n+4	↓7	↑7	8	8	↓7	↑7	8	8
31	4n+1	8	8	8	8	8	8	↓7	↑7
	4n+2	8	8	↑7	↓7	8	8	8	8
	4n+3	8	8	8	8	↑7	↓7	8	8
	4n+4	↓7	↑7	8	8	8	8	8	8
32	4n+1	8	8	8	8	8	8	8	8
	4n+2	8	8	8	8	8	8	8	8
	4n+3	8	8	8	8	8	8	8	8
	4n+4	8	8	8	8	8	8	8	8

- Remarks 1. n: Integer from 0 to 31.
 2. ↑A: Rising edge of pulse during line A output.
 3. ↓A: Rising edge of pulse at start of line A output.
 4. A: PWM pulse width (A/8)

5.7.2 Full-dot frame rate control

When combined with pulse width modulation as described in Table 5-15, the μPD16498's frame speed is based on 8-frame cycles. The subsampling pattern is output based on the palette stored in the IC.

Full-Dot Gray-Scale Palette (Output Pulse Width: x/8 Pulses)

Gray scale level	Frames								Comments
	1	2	3	4	5	6	7	8	
0	0	0	0	0	0	0	0	0	OFF data
1	1	1	0	0	0	0	0	0	
2	1	1	0	0	1	1	0	0	
3	1	1	1	1	1	1	0	0	
4	1	1	1	1	1	1	1	1	
5	2	2	1	1	1	1	1	1	
6	2	2	1	1	2	2	1	1	
7	2	2	2	2	2	2	1	1	
8	2	2	2	2	2	2	2	2	
9	3	3	2	2	2	2	2	2	
10	3	3	2	2	3	3	2	2	
11	3	3	3	3	3	3	2	2	
12	3	3	3	3	3	3	3	3	
13	4	4	3	3	3	3	3	3	
14	4	4	3	3	4	4	3	3	
15	4	4	4	4	4	4	3	3	
16	4	4	4	4	4	4	4	4	50%
17	5	5	4	4	4	4	4	4	
18	5	5	4	4	5	5	4	4	
19	5	5	5	5	5	5	4	4	
20	5	5	5	5	5	5	5	5	
21	6	6	5	5	5	5	5	5	
22	6	6	5	5	6	6	5	5	
23	6	6	6	6	6	6	5	5	
24	6	6	6	6	6	6	6	6	
25	7	7	6	6	6	6	6	6	
26	7	7	6	6	7	7	6	6	
27	7	7	7	7	7	7	6	6	
28	7	7	7	7	7	7	7	7	
29	8	8	7	7	7	7	7	7	
30	8	8	7	7	8	8	7	7	
31	8	8	8	8	8	8	7	7	
32	8	8	8	8	8	8	8	8	100%

Remark The gradation in the Comments column are images of the gray-scale level.

5.7.3 Line shift driver

If the frame rate control is performed with equal pulse widths and the same gray scale is displayed on the LCD's full screen, problems such as flickering may occur on the LCD panel. The μPD16498 provides a line shift driver as a countermeasure against such screen image problems.

Using 8 frames per cycle, the segment PWM output timing is shifted among the common outputs, as shown in Table 5-16 below.

Table 5-16. Line Shift Driver

Frame	Turn 1								Turn 2											
	1	2	3	4	5	6	7	8	1	2	3	4	5	6	7	8	1	2	3	4
COM ₁	F1	F2	F3	F4	F5	F6	F7	F8	F1	F2	F3	F4	F5	F6	F7	F8	F1	F2	F3	F4
COM ₂	F5	F6	F7	F8	F1	F2	F3	F4	F5	F6	F7	F8	F1	F2	F3	F4	F5	F6	F7	F8
COM ₃	F3	F4	F5	F6	F7	F8	F1	F2	F3	F4	F5	F6	F7	F8	F1	F2	F3	F4	F5	F6
COM ₄	F7	F8	F1	F2	F3	F4	F5	F6	F7	F8	F1	F2	F3	F4	F5	F6	F7	F8	F1	F2
COM ₅	F1	F2	F3	F4	F5	F6	F7	F8	F1	F2	F3	F4	F5	F6	F7	F8	F1	F2	F3	F4
COM ₆	F5	F6	F7	F8	F1	F2	F3	F4	F5	F6	F7	F8	F1	F2	F3	F4	F5	F6	F7	F8
COM ₇	F3	F4	F5	F6	F7	F8	F1	F2	F3	F4	F5	F6	F7	F8	F1	F2	F3	F4	F5	F6
COM ₈	F7	F8	F1	F2	F3	F4	F5	F6	F7	F8	F1	F2	F3	F4	F5	F6	F7	F8	F1	F2
COM ₉	F1	F2	F3	F4	F5	F6	F7	F8	F1	F2	F3	F4	F5	F6	F7	F8	F1	F2	F3	F4
COM ₁₀	F5	F6	F7	F8	F1	F2	F3	F4	F5	F6	F7	F8	F1	F2	F3	F4	F5	F6	F7	F8
•	•	•	•	•	•	•	•	•	•	•	•	•	•	•	•	•	•	•	•	•

Remark Fx: Pulse width modulated output frame (See 5.7.2 Full-dot frame rate control).

Figure 5-22. Full Dot Frame Rate Control

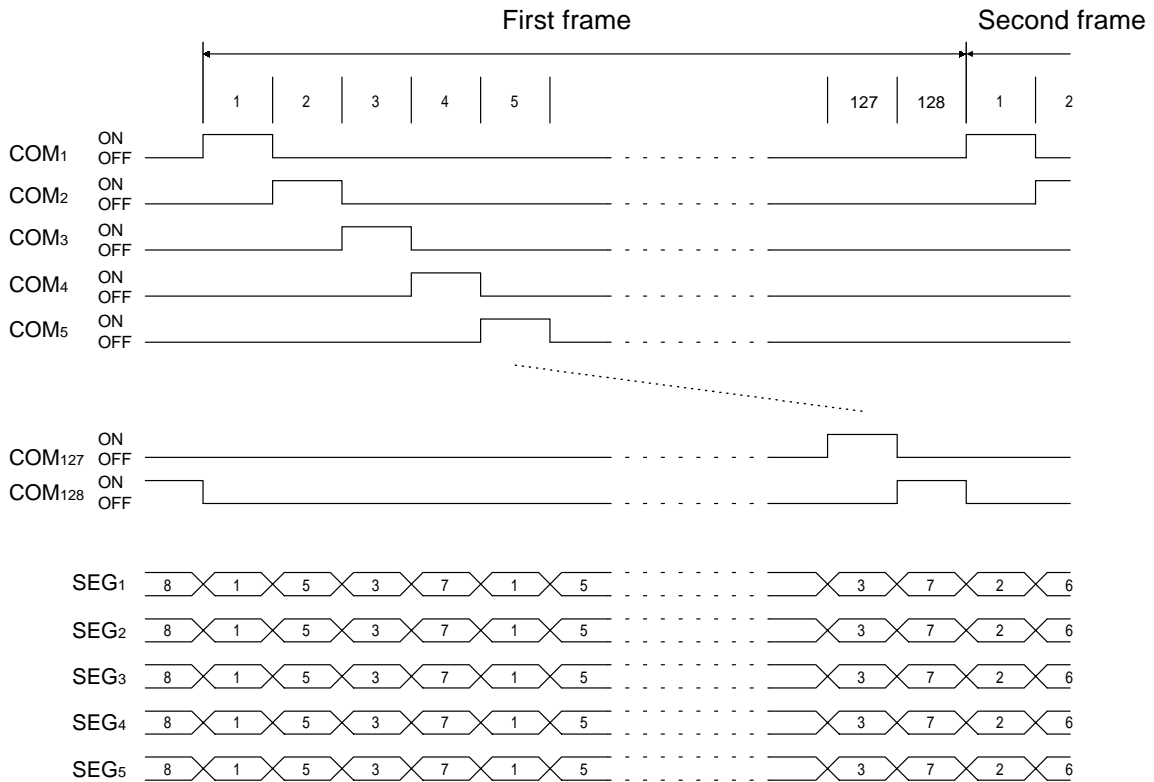

Remark Numerical values in the segment data correspond to the gray-scale palette's frame numbers.

Figure 5-23. Line Shift Driver Image

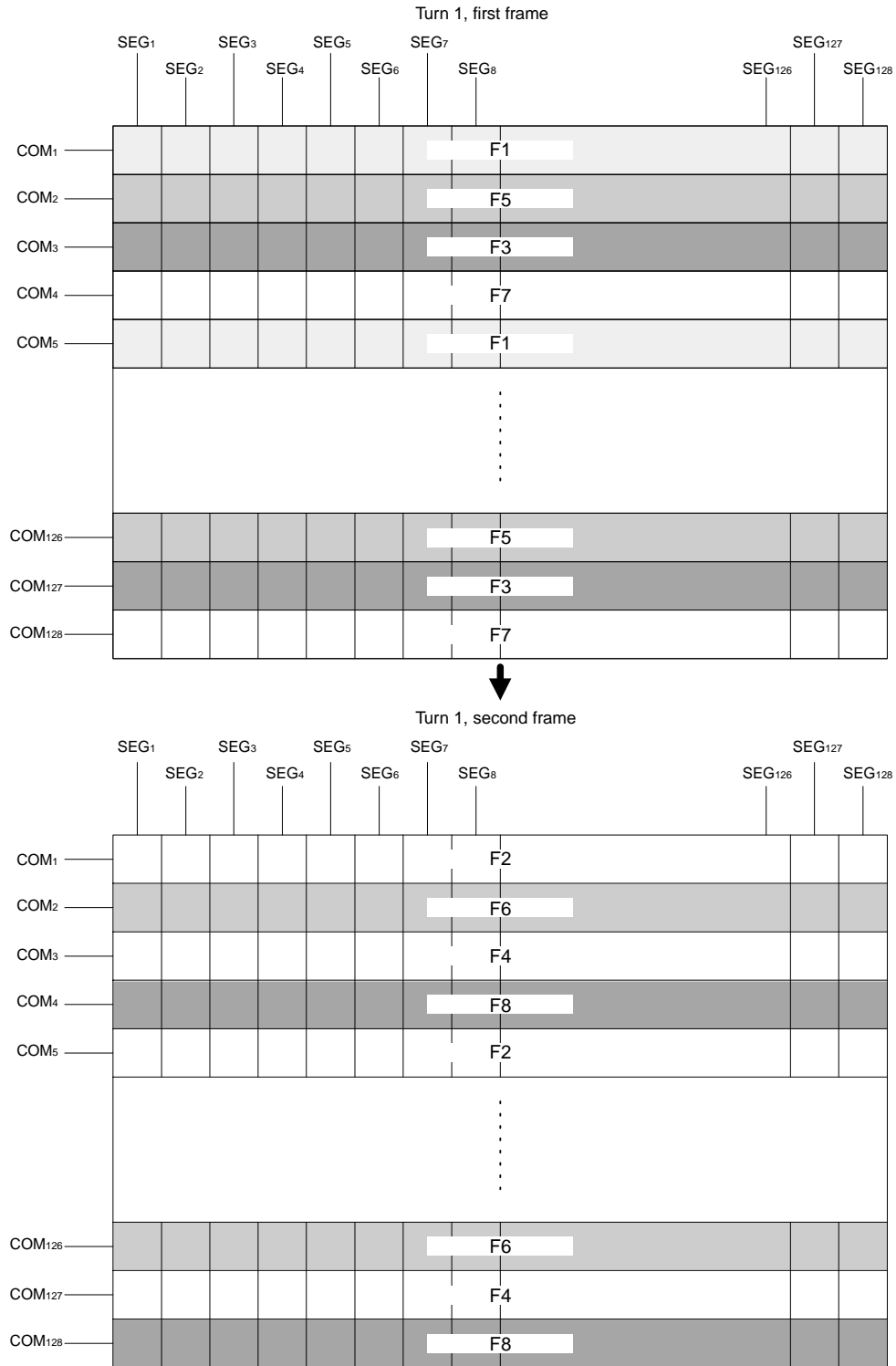

5.7.4 Display size settings

The μPD16498 can be set for any duty value from 1/1 to 1/128. This duty setting can be made via bits DT6 to DT0 in the duty setting register (R5), as shown in Table 5-17.

Table 5-17. Duty Settings

DT6	DT5	DT4	DT3	DT2	DT1	DT0	Duty
0	0	0	0	0	0	0	1/1
0	0	0	0	0	0	1	1/2
0	0	0	0	0	1	0	1/3
0	0	0	0	0	1	1	1/4
			:				:
1	1	1	1	1	0	1	1/126
1	1	1	1	1	1	0	1/127
1	1	1	1	1	1	1	1/128

5.7.5 Setting of LCD AC driver's inversion cycle and AC driver's inversion position

The μPD16498 enable any setting to be made for the AC driver's inversion position and the inversion position shift amount for each displayed frame via settings made in the AC driver inversion cycle register (R6) and the AC driver inversion position shift register (R7) for normal display mode or via settings made in the partial AC driver inversion cycle register (R8) and the partial AC driver inversion position shift register (R9) for partial display mode.

In normal display mode, the AC driver inversion cycle can be set for any number of inverted (reverse display) lines listed in Table 5-18, based on the NID6 to NID0 bit settings in the AC driver inversion cycle register (R6).

If the screen display size has been changed via settings made in the duty setting register (R5), the NIDn values are automatically overwritten by values from the corresponding DTYn bits.

The shift amount for each displayed frame can be set as shown in Table 5-19 via settings made to bits MSD6 to MSD0 in the AC driver inversion position shift register (R7).

Table 5-18. Settings of AC Driver Inversion Cycle Register (R6)

NID6	NID5	NID4	NID3	NID2	NID1	NID0	Inverted Lines
0	0	0	0	0	0	0	1
0	0	0	0	0	0	1	2
0	0	0	0	0	1	0	3
0	0	0	0	0	1	1	4
			:				:
1	1	1	1	1	0	1	126
1	1	1	1	1	1	0	127
1	1	1	1	1	1	1	128

Table 5-19. Settings of AC Driver Inversion Position Shift Register

MSD6	MSD5	MSD4	MSD3	MSD2	MSD1	MSD0	Inversion Position Shift Amount
0	0	0	0	0	0	0	0
0	0	0	0	0	0	1	1
0	0	0	0	0	1	0	2
0	0	0	0	0	1	1	3
			:				:
1	1	1	1	1	0	1	125
1	1	1	1	1	1	0	126
1	1	1	1	1	1	1	127

In partial display mode, the AC driver inversion cycle can be set for any number of inverted (reverse display) lines listed in Table 5-20, based on the PID5 to PID0 bit settings in the partial AC driver inversion cycle register (R8).

The shift amount for each displayed frame can be set as shown in Table 5-21 via settings made to bits PSD5 to PSD0 in the partial AC driver inversion position shift register (R9).

Table 5-20. Settings of Partial AC Driver Inversion Cycle Register (R8)

PID5	PID4	PID3	PID2	PID1	PID0	Inverted Lines
0	0	0	0	0	0	1
0	0	0	0	0	1	2
0	0	0	0	1	0	3
0	0	0	0	1	1	4
		:				:
1	0	0	0	1	1	36
1	0	0	1	0	0	37
1	0	0	1	0	1	38

Table 5-21. Setting of Partial AC Driver Inversion Position Shift Register (R9)

PSD5	PSD4	PSD3	PSD2	PSD1	PSD0	Inversion Position Shift Amount
0	0	0	0	0	0	0
0	0	0	0	0	1	1
0	0	0	0	1	0	2
0	0	0	0	1	1	3
			:			:
1	0	0	0	1	1	35
1	0	0	1	0	0	36
1	0	0	1	0	1	37

Be sure to maintain the following relationship among the display size, AC inversion cycle, and AC inversion position.

$$\text{Display size (duty)} \geq \text{AC inversion cycle} \geq \text{AC inversion shift amount}$$

Caution Setting a small inversion cycle will cause a reduction in the IC's display drive capacity and an increase in the current consumption.

We therefore recommend determining the inversion cycle after making a thorough evaluation of the actual LCD panel.

5.8 Display Modes

5.8.1 Partial display mode

The μPD16498 include a function for outputting a display that uses only part of the LCD panel. The duty setting for partial display mode can be selected as 1/12, 1/25, or 1/38. Parts of the LCD panel that are outside of the specified display area are scanned with non-select waveforms. The partial start line address register (R21) is used to select which part of the LCD panel to use for the partial display. The display area starts from the start line address and includes the number of lines (12, 25, or 38 lines) that has been specified via the partial display mode setting (R10).

When entering this mode, the booster is set to the boost level number that has been set via the power system control register 3 (partial display boost register) (R34) and the display start line is fixed as 00H. In addition, the bias level is automatically changed to the value that has been set via the partial display mode setting (R10). The relationship between the oscillator's frequency and the frame frequency in partial mode is also automatically changed.

Figure 5-24 shows the mutual relationship between the partial line start address and the LCD display.

When using the partial display mode, the blinking and reverse display functions can be used in the same way as during full-dot display mode.

Caution The LCD driver voltage is lower in partial display mode, because the duty is lower than in normal display mode. There may be restrictions on the usable duty depending on the LCD panel characteristics. We recommend determining the partial duty after making a thorough evaluation of the actual LCD panel.

Figure 5-24. Relationship Between Partial Line Start Address and LCD Display (in Partial Display Mode)

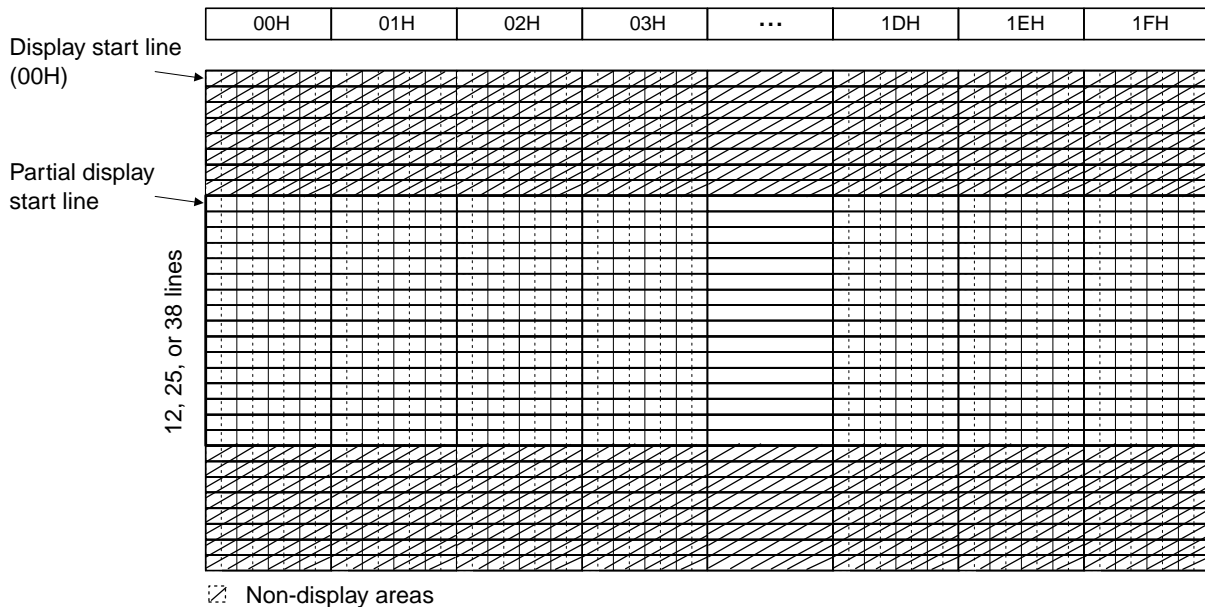

Caution In partial display mode, the display start line setting register (R12) command is ignored.

When switching from normal display mode to partial display mode or from partial display mode to normal display mode, if an electric charge remains in the smoothing capacitor that is connected between the LCD drive voltage pins (V_{LCD}, V_{LC1} to V_{LC4}) and the V_{SS} pin, troubles such as a brief all-black display may occur during the mode switching operation. To avoid such troubles, we recommend using the following power-on sequence.

(1) Normal display → partial display switch sequence

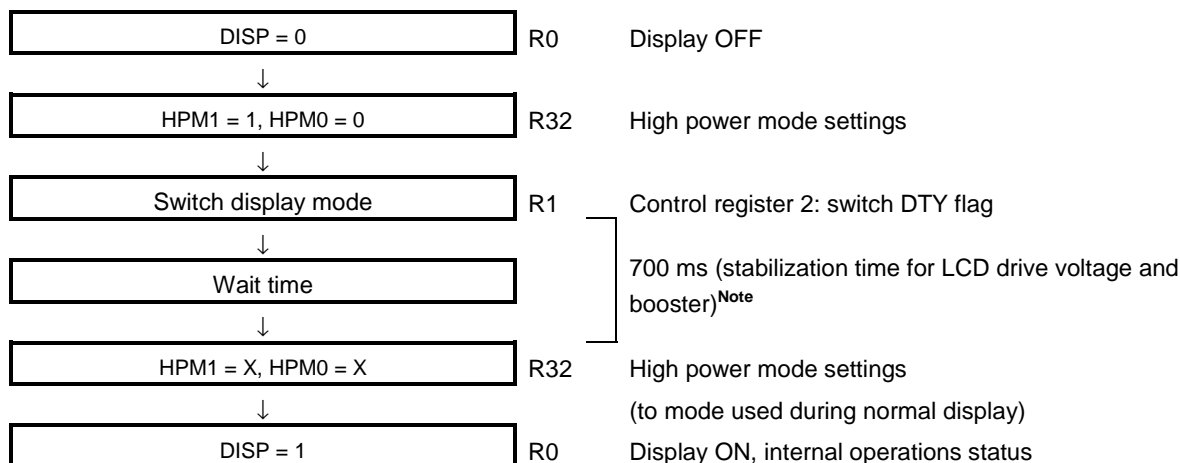

Note This 700 ms wait time indicates the time for the V_{LCD} level to change from 15 V to 6 V and thus varies according to the panel characteristics and the capacitance value of the boost/smoothing capacitor. We recommend determining the wait time after making a thorough evaluation of the actual device.

(2) Partial display → Normal display switch sequence

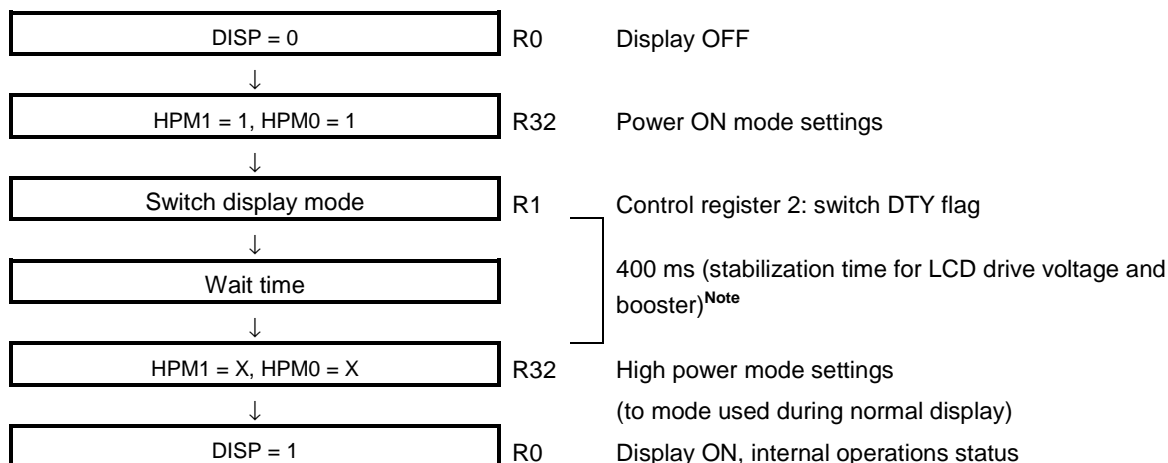

Note This 400 ms wait time indicates the time for the V_{LCD} level to change from 6 V to 15 V and thus varies according to the panel characteristics and the capacitance value of the boost/smoothing capacitor. We recommend determining the wait time after making a thorough evaluation of the actual device.

5.8.2 Monochrome (black/white) display

The μPD16498 provides both a four-level gray scale display mode and a monochrome display mode.

To switch to the monochrome display mode, set GRAY = H. The display RAM for one screen of monochrome display mode contents is configured as 128 bits x 128 bits (16 x 8 bits). When using these IC's in monochrome display mode, two screens of data can be written to the display RAM and the two screens can be switched by setting the DSEL bit in the control register 2 (R1). Screen 1 is displayed on the LCD panel when DSEL = L and screen 2 is displayed when DSEL = H.

When writing data, the display RAM uses the same X address (00H to 0FH) and Y address and the BWW bit value in the control register 2 (R1) determines which of the two screens the data will be written to: when BWW = L, data is written to screen 1 and when BWW = H, data is written to screen 2, as shown in Figure 5-25.

When accessing a specified bit, specify both the X address and Y address. The display data in D₀ to D₇ (sent from the CPU) corresponds to the SEGx portions of the LCD display, as shown in Figure 5-26. Figure 5-27 shows the relationship between the display data in monochrome display mode and the page/column addresses.

Figure 5-25. Display RAM Image in Monochrome (Black/White) Mode

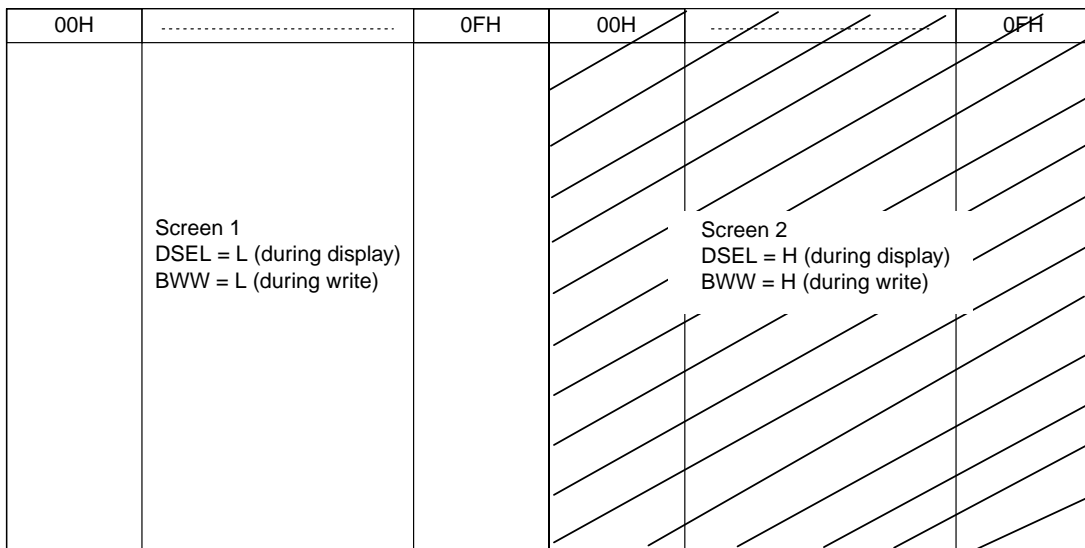

Figure 5-26. Relationship Between Display Data and LCD Display

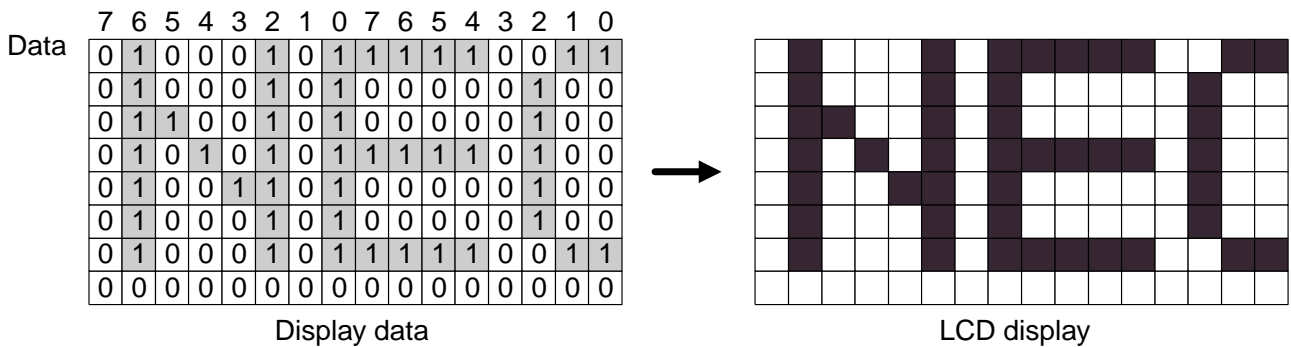
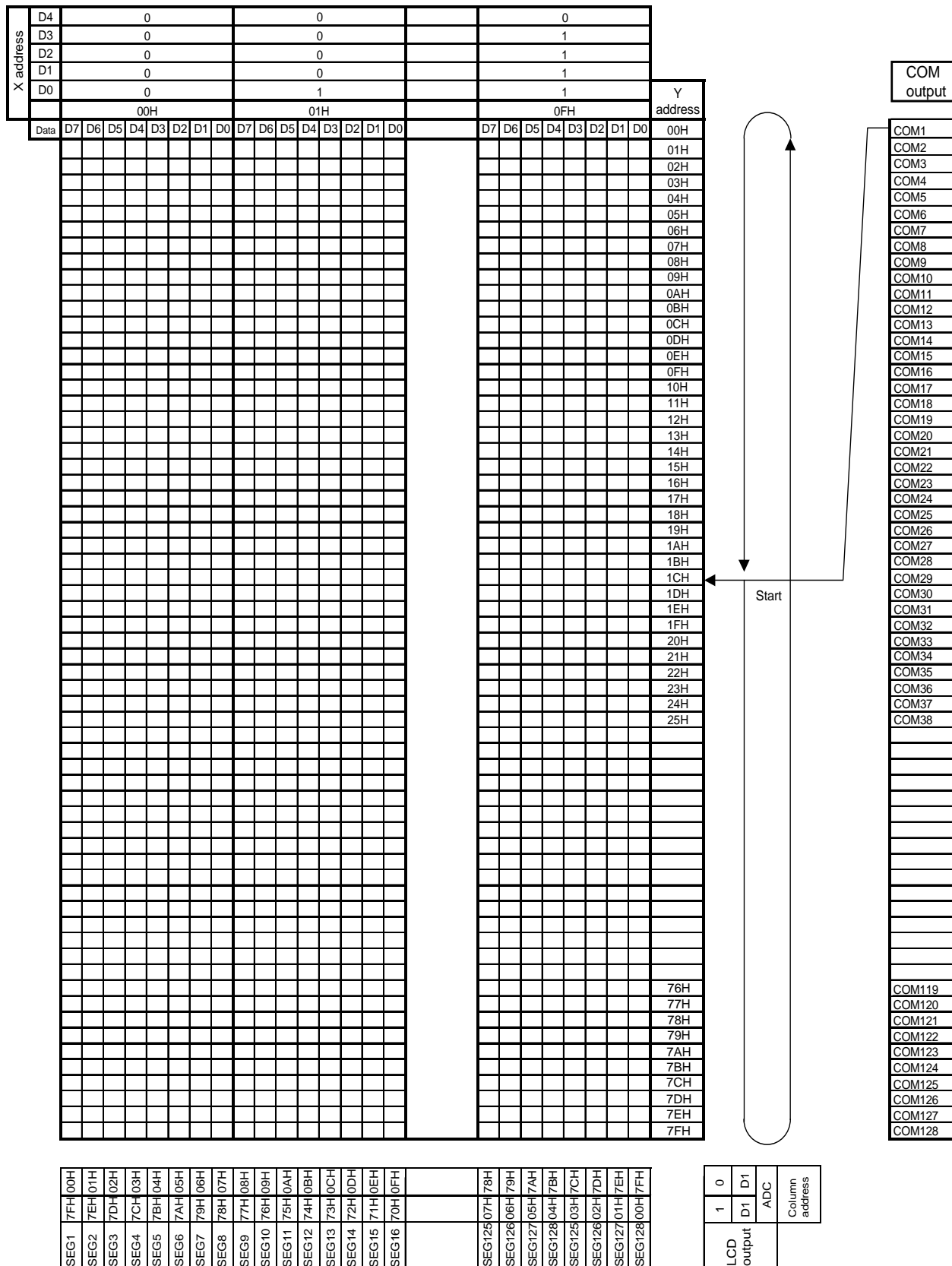

Figure 5-27. Relation Between the Display Data and X/Y Address
(in Monochrome Display Mode)



5.8.3 Icon display

The μPD16498 includes 20 segment pins and two common pins (both output the same signal) for displaying icons, independent of the pins used to display graphics. Icons are static-driven and their contrast can be adjusted at 32 levels using phase modulation.

The static icon data RAM that is used to record icon display data contains display data (DIS) and blink data (BRI) in a 20-bit x 2 configuration, as shown in Table 5-22 (where ADC = 0) and Table 5-23 (where ADC = 1).

Addresses in the static icon data RAM are specified via the static icon address register (R40) and then data is written to memory.

The icon blink function operates only when the display data setting is 1, the blink data setting is 1, and the IBL setting is also 1 (R1).

Table 5-22. Static Icon Data RAM (ADC = 0)

Address	Static Icon Output Number (PSEGN)							
	DIS	BRI	DIS	BRI	DIS	BRI	DIS	BRI
	D7	D6	D5	D4	D3	D2	D1	D0
00H	1		2		3		4	
01H	5		6		7		8	
02H	9		10		11		12	
03H	13		14		15		16	
04H	17		18		19		20	

Table 5-23. Static Icon Data RAM (ADC = 1)

Address	Static Icon Output Number (PSEGN)							
	DIS	BRI	DIS	BRI	DIS	BRI	DIS	BRI
	D7	D6	D5	D4	D3	D2	D1	D0
00H	20		19		18		17	
01H	16		15		14		13	
02H	12		11		10		9	
03H	8		7		6		5	
04H	4		3		2		1	

Adjustment of contrast is controlled by phase modulation set via the static icon contrast (R42). The pulse width of the ON signal that is output in static drive mode is divided into 32 levels (1/32 to 32/32 pulse width) and the dot output's timing changes during output according to the phase modulation ratio recorded in bits ICS4 to ICS0 of the static icon contrast (R42), as shown in Table 5-24.

Table 5-24. Dot Output Timing Changes

ICS4	ICS3	ICS2	ICS1	ICS0	Phase Modulation Ratio
0	0	0	0	0	0/32
0	0	0	0	1	1/32
0	0	0	1	0	2/32
0	0	0	1	1	3/32
		:			:
1	1	1	0	1	29/32
1	1	1	1	0	30/32
1	1	1	1	1	31/32

Figure 5-28. Phase Modulation Driver Waveforms

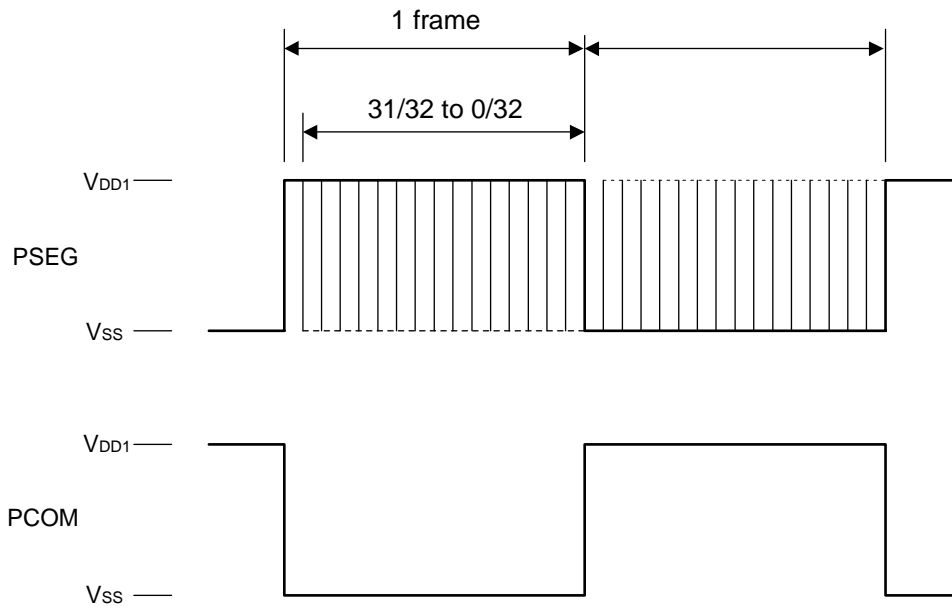

Example of phase modulation amount for displaying 10H

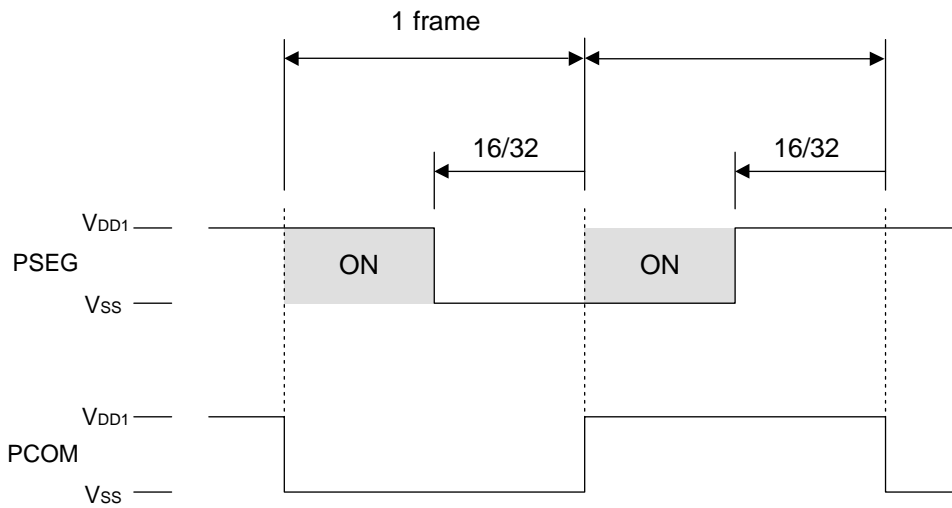

5.9 Reset

In the μPD16498, a reset is executed when the /RES input is at low level or when a reset command is entered. The IC is reset to its default settings. These default settings are listed in the table below.

Register	Number	/RES	Reset Command	
Control register 1	R0	Enabled (DISP flag only)	Enabled	
Control register 2	R1	Enabled (IDIS flag only)		
X address register	R3	Disabled	Enabled	
Y address register	R4			
Duty setting register	R5			
AC driver inversion cycle register	R6			
AC driver inversion position shift register	R7			
Partial AC driver inversion cycle register	R8			
Partial AC driver inversion position shift register	R9			
Partial display mode setting register	R10			
Display memory access register ^{Note}	R11			Disabled
Display start line set register	R12			Enabled
Blink X address register	R13		Enabled	
Blink start line address register	R14			
Blink end line address register	R15			
Blink data memory access register ^{Note}	R16			Disabled
Inverted X address register	R17			Enabled
Inversion start line address register	R18			
Inversion end line address register	R19			
Inverted data memory access register ^{Note}	R20			Disabled
Partial start line address register	R21			Enabled
Gray scale data register 1 (0, 0)	R23			Enabled
Gray scale data register 2 (0, 1)	R24			
Gray scale data register 3 (1, 0)	R25			
Gray scale data register 4 (1, 1)	R26			
Partial gray scale data register 1 (0, 0)	R27			
Partial gray scale data register 2 (0, 1)	R28			
Partial gray scale data register 3 (1, 0)	R29			
Partial gray scale data register 4 (1, 1)	R30			
Power system control register 1	R32	Enabled		
Power system control register 2	R33			
Power system control register 3	R34			
Electronic volume register	R35			
Partial electronic volume register	R36			
Boost adjustment register	R37			
Static icon address register	R40			
Static icon memory access register ^{Note}	R41		Disabled	
Static icon contrast register	R42		Enabled	
RAM test mode setting register	R44		Enabled	
Signature read register	R45			
			Disabled	

Enabled: Default value is input, Disabled: Default value is not input

Note When using the /RES pin to reset, the contents of memory are not retained. Use the reset command to reset if the memory contents need to be retained.

- Cautions 1. Using the /RES pin to reset initializes the shift clock counter.**
2. Always input the reset command as the first command after power ON.

6. COMMAND REGISTERS

The μ PD16498 chip uses a combination of RS, /RD (E), and /WR (R,/W) signals to identify data bus signals.

Command interpretation and execution is performed using internal timing that does not depend on any external clock. Therefore, processing is very fast and there is usually no need to check for a busy status.

The i80 series CPU interface activates read commands using a low pulse input to the /RD pin and activates write commands using a low pulse input to the /WR pin. The M68 series CPU interface sets read mode using a high level input to the R,/W pin and sets write mode using a low level input to the same pin. It activates both read and write commands using a high-level pulse input to the E pin.

Command descriptions using an i80 series CPU interface are shown as follows. The M68 series CPU interface differs from the i80 series CPU interface in that /RD (E) is at high level during status read and display data read operations, as shown in the following command descriptions and command table.

If the serial interface has been selected, data is input sequentially starting from D₇.

6.1 Control Register 1 (R0)

This command specifies the μPD16498's general operation modes.

RS	E /RD	R,/W /WR	D7	D6	D5	D4	D3	D2	D1	D0
1	1	0	RMW	DISP	STBY	BLD	IVD	HALT	ADC	COMR

Flag	Function
RMW	0: Address is incremented after both write access and read access. 1: Read/modify/write mode (Address is incremented only after write access)
DISP	0: Display OFF (All LCD output pins output the V _{SS} level and oscillator and DC/DC converter are operating) 1: Display ON
STBY	0: Normal operation 1: Internal operation and oscillation are stopped. Display is OFF.
BLD	The blinking dots are specified via the blink start/end line address registers and data is set to blink data RAM. 0: Stop blinking 1: Start blinking
IVD	The number of inverted dots is specified via the inversion start/end line address registers and data is set to inverted data RAM. 0: Stop inversion 1: Start inversion
HALT	0: Start internal operation 1: Stop internal operation (since different display modes are used, when switching between partial and normal display modes, the LCD output pins all output the V _{SS} level and the oscillator is operating, but the DC/DC converter is stopped)
ADC ^{Note}	The column address corresponding to the SEG outputs (see Table 6-1) for displaying the contents of the display data RAM.
COMR ^{Note}	This inverts (reverses) the scan direction for common outputs. (See Table 6-2)

Note The reset command must be executed before changing this flag's setting.

Table 6-1. Relationship between Display RAM Column Address and SEG Outputs

SEG Output	SEG ₁		SEG ₁₂₈
ADC (D ₁)	0	→	7FH
	1	←	00H

Table 6-2. Relationship between Common Scan Circuit and Scan Direction

COM Output	Scan Direction		
COMR (D ₀)	0	COM ₁	→
	1	COM ₁₂₈	→

Default settings (initial values set by reset command)

D7	D6	D5	D4	D3	D2	D1	D0
0	0	0	0	0	0	0	0

6.2 Control Register 2 (R1)

This command specifies the μPD16498's general operation modes.

RS	E /RD	R,/W /WR	D7	D6	D5	D4	D3	D2	D1	D0
1	1	0	FDM	IBL	IDIS	DSEL	BWW	GRAY	DTY	INC

Flag	Function
FDM	Settings for full screen display mode 0: Normal operation 1: Full screen display (set entire screen to ON) (When using four-level gray scale, gray-scale level 32 is output for full screen display).
IBL	Static icon blink control, icons with "1" as blink data are blinking. 0: Static icon blink OFF 1: Static icon blink ON
IDIS	0: Static icon display OFF (All static LCD output pins output the V _{SS} level and oscillator and DC/DC converter are operating) 1: Static icon display ON
DSEL	Selects display screen during monochrome display mode. 0: Screen 1 1: Screen 2
BWW	Selects data write screen during monochrome display mode. 0: Screen 1 1: Screen 2
GRAY ^{Note}	0: 4-level gray scale display mode 1: Monochrome display mode
DTY ^{Note}	0: Normal display mode (1/1 to 1/128 duty) 1: Partial display mode (1/12, 1/25, or 1/38 duty, 1/5 or 1/6 bias)
INC	0: Increments X address at each access 1: Increments Y address at each access

Note The HALT command must be executed before changing this flag's setting.

Table 6-3. Relationship between IC's Functions and Display Modes

Item	Normal Display Mode (DTY = 0)		Partial Display Mode (DTY = 1)
Duty	1/1 to 1/128 duty	↔	1/12, 1/25, or 1/38 duty
Booster	×4, ×5, ×6, ×7, ×8, ×9	↔	×2, ×3, ×4
Bias level	1/11, 1/12, 1/10, 1/9, 1/8, 1/7	↔	1/5, 1/6
Gray scale data	Uses levels set to the gray scale data registers (R23 to R26)	↔	Uses levels set to the partial gray scale data registers (R27 to R30)
(1+Rb/Ra) V _{LCd} regulator resistance factor	Uses values of VRR2 to VRR0 in the power system control register 2 (R33)	↔	Uses values of PVR2 to PVR0 in the power system control register 2 (R33)
Electronic volume	Uses value from the electronic volume register (R35)	↔	Uses value from the partial electronic volume register (R36)

Default settings (initial values set by reset command)

D7	D6	D5	D4	D3	D2	D1	D0
0	0	0	0	0	0	0	0

6.3 Reset Command (R2)

When this command is input, the IC's registers (R0 to R44) are reset to their initial values. But the contents of memory are retained.

Always input the reset command as the first command after power application.

RS	D7	D6	D5	D4	D3	D2	D1	D0
1	0	0	0	0	0	0	0	1

6.4 X Address Register (R3)

The X address register specifies the X address in the display RAM accessed by the CPU. This address is automatically incremented each time the display RAM is accessed (INC = 0, RMW = 0).

RS	D7	D6	D5	D4	D3	D2	D1	D0
1	-	-	-	XA4	XA3	XA2	XA1	XA0

Default settings (initial values set by reset command)

D7	D6	D5	D4	D3	D2	D1	D0
-	-	-	0	0	0	0	0

6.5 Y Address Register (R4)

The Y address register specifies the Y address in the display RAM accessed by the CPU. This address is automatically incremented each time the display RAM is accessed (INC = 1, RMW = 0).

RS	D7	D6	D5	D4	D3	D2	D1	D0
1	-	YA6	YA5	YA4	YA3	YA2	YA1	YA0

Default settings (initial values set by reset command)

D7	D6	D5	D4	D3	D2	D1	D0
-	0	0	0	0	0	0	0

6.6 Duty Setting Register (R5)

The display duty can be set to any duty ratio between 1/1 and 1/128, as is shown in Table 6-4. Before modifying this register, be sure to use the HALT command (control register 1 (R0)) to stop internal operations.

RS	D7	D6	D5	D4	D3	D2	D1	D0
1	–	DT6	DT5	DT4	DT3	DT2	DT1	DT0

Table 6-4. Duty Setting Register (R5) Settings

DT6	DT5	DT4	DT3	DT2	DT1	DT0	Duty
0	0	0	0	0	0	0	1/1
0	0	0	0	0	0	1	1/2
0	0	0	0	0	1	0	1/3
0	0	0	0	0	1	1	1/4
			:				:
1	1	1	1	1	0	1	1/126
1	1	1	1	1	1	0	1/127
1	1	1	1	1	1	1	1/128

Default settings (initial values set by reset command)

D7	D6	D5	D4	D3	D2	D1	D0
–	1	1	1	1	1	1	1

6.7 AC Driver Inversion Cycle Register (R6)

The AC driver's line position for normal display mode can be set as shown in Table 6-5. When a DTYn value is changed in the duty setting register (R5), the NIDn value is automatically overwritten by the DTYn value.

RS	D7	D6	D5	D4	D3	D2	D1	D0
1	–	NID6	NID5	NID4	NID3	NID2	NID1	NID0

Table 6-5. AC Driver Inversion Cycle Register (R6) Settings

NID6	NID5	NID4	NID3	NID2	NID1	NID0	Inversion Line
0	0	0	0	0	0	0	1
0	0	0	0	0	0	1	2
0	0	0	0	0	1	0	3
0	0	0	0	0	1	1	4
			:				:
1	1	1	1	1	0	1	126
1	1	1	1	1	1	0	127
1	1	1	1	1	1	1	128

Default settings (initial values set by reset command)

D7	D6	D5	D4	D3	D2	D1	D0
–	1	1	1	1	1	1	1

6.8 AC Driver Inversion Position Shift Register (R7)

This register shifts the inversion position for each frame in normal display mode by the shift amount shown in Table 6-6.

RS	D7	D6	D5	D4	D3	D2	D1	D0
1	–	MSD6	MSD5	MSD4	MSD3	MSD2	MSD1	MSD0

Table 6-6. AC Driver Inversion Position Shift Register (R7) Settings

MSD5	MSD5	MSD4	MSD3	MSD2	MSD1	MSD0	Inversion Position Shift Amount
0	0	0	0	0	0	0	0
0	0	0	0	0	0	1	1
0	0	0	0	0	1	0	2
0	0	0	0	0	1	1	3
			:				:
1	1	1	1	1	0	1	125
1	1	1	1	1	1	0	126
1	1	1	1	1	1	1	127

Default settings (initial values set by reset command)

D7	D6	D5	D4	D3	D2	D1	D0
–	0	0	0	0	0	0	0

6.9 Partial AC Driver Inversion Cycle Register (R8)

The AC driver's line position can be set as shown in Table 6-7.

When a PDTn value is changed in the partial display mode setting register (R10), the PIDn value is automatically overwritten by the PDTn value.

RS	D7	D6	D5	D4	D3	D2	D1	D0
1	–	–	PID5	PID4	PID3	PID2	PID1	PID0

Table 6-7. Partial AC Driver Inversion Cycle Register (R8) Settings

PID5	PID4	PID3	PID2	PID1	PID0	Inversion Line
0	0	0	0	0	0	1
0	0	0	0	0	1	2
0	0	0	0	1	0	3
0	0	0	0	1	1	4
			:			:
1	0	0	0	1	1	36
1	0	0	1	0	0	37
1	0	0	1	0	1	38

Default settings (initial values set by reset command)

D7	D6	D5	D4	D3	D2	D1	D0
–	–	1	0	0	1	0	1

6.10 Partial AC Driver Inversion Position Shift Register (R9)

This register shifts the inversion position for each frame by the shift amount shown in Table 6-8.

RS	D7	D6	D5	D4	D3	D2	D1	D0
1	–	–	PSD5	PSD4	PSD3	PSD2	PSD1	PSD0

Table 6-8. Partial AC Driver Inversion Position Shift Register (R9) Settings

PSD5	PSD4	PSD3	PSD2	PSD1	PSD0	Inversion Position Shift Amount
0	0	0	0	0	0	0
0	0	0	0	0	1	1
0	0	0	0	1	0	2
0	0	0	0	1	1	3
		:				:
1	0	0	0	1	1	35
1	0	0	1	0	0	36
1	0	0	1	0	1	37

Default settings (initial values set by reset command)

D7	D6	D5	D4	D3	D2	D1	D0
–	–	–	0	0	0	0	0

6.11 Partial Display Mode Setting Register (R10)

This command specifies the operation mode to be used in the μPD16498's partial display mode.

Before modifying this register, be sure to use the HALT command (control register 1 (R0)) to stop internal operations.

RS	D7	D6	D5	D4	D3	D2	D1	D0
1	–	–	–	–	PBIS	–	PDT1	PDT0

Flag	Function		
PBIS	Sets bias level for partial display mode 0: 1/5 bias 1: 1/6 bias		
PDT1, PDT0	PDT1	PDT0	Duty in partial display mode
	0	0	1/38 duty
	0	1	1/25 duty
	1	0	1/12 duty
	1	1	Prohibited

With the setting of 1/12 duty, the level voltage (VLCn) for driving the liquid crystal panel may not reach the set value. Thoroughly evaluate the relationship between the duty and driving voltage with the actual system.

Default settings (initial values set by reset command)

D7	D6	D5	D4	D3	D2	D1	D0
–	–	–	–	0	–	0	0

6.12 Display Memory Access Register (R11)

The display memory access register is used when accessing the display RAM. When this register is write-accessed, data is written directly to the display RAM. When this register is read-accessed, data from the display RAM is first latched to this register before being sent to the bus during the next read operation. Accordingly, one dummy read access is required after display RAM access has been set.

When using reset command to reset, the contents of memory are retained.

RS	D7	D6	D5	D4	D3	D2	D1	D0
1	D7	D6	D5	D4	D3	D2	D1	D0

Default settings (initial values set by reset command)

D7	D6	D5	D4	D3	D2	D1	D0
–	–	–	–	–	–	–	–

6.13 Display Start Line Setting Register (R12)

Display start line set specifies the top line in the display.

RS	D7	D6	D5	D4	D3	D2	D1	D0
1	–	DSL6	DSL5	DSL4	DSL3	DSL2	DSL1	DSL0

Default settings (initial values set by reset command)

D7	D6	D5	D4	D3	D2	D1	D0
–	0	0	0	0	0	0	0

6.14 Blink X Address Register (R13)

The blink X address register specifies the X address of the blink data RAM accessed by the CPU. This address is automatically incremented each time the blink data RAM is accessed.

RS	D7	D6	D5	D4	D3	D2	D1	D0
1	–	–	–	–	BXA3	BXA2	BXA1	BXA0

Default settings (initial values set by reset command)

D7	D6	D5	D4	D3	D2	D1	D0
–	–	–	–	0	0	0	0

6.15 Blink Start Line Address Register (R14)

The blink start line address register specifies the start line address of the display RAM accessed when the CPU uses blink display mode. The range of blinking lines is determined based on the contents of this register and the blink end line address register.

RS	D7	D6	D5	D4	D3	D2	D1	D0	Setting
1	–	BSL6	BSL5	BSL4	BSL3	BSL2	BSL1	BSL0	–

Default settings (initial values set by reset command)

D7	D6	D5	D4	D3	D2	D1	D0
–	0	0	0	0	0	0	0

6.16 Blink End Line Address Register (R15)

The blink end line address register specifies the end line address of the display RAM accessed when the CPU uses blink display mode. The range of blinking lines is determined based on the contents of this register and the blink start line address register.

RS	D7	D6	D5	D4	D3	D2	D1	D0	Setting
1	–	BEL6	BEL5	BEL4	BEL3	BEL2	BEL1	BEL0	–

Default settings (initial values set by reset command)

D7	D6	D5	D4	D3	D2	D1	D0
–	0	0	0	0	0	0	0

6.17 Blink Data Memory Access Register (R16)

The blink data memory access register is used to access the blink data RAM. When this register is write-accessed, data is written directly to the blink data RAM.

When using reset command to reset, the contents of memory are retained.

RS	D7	D6	D5	D4	D3	D2	D1	D0
1	D7	D6	D5	D4	D3	D2	D1	D0

Data	Status
0	Normal
1	Blink

Default settings (initial values set by reset command, all data)

D7	D6	D5	D4	D3	D2	D1	D0
0	0	0	0	0	0	0	0

6.18 Inverted X Address Register (R17)

The inverted X address register specifies the X address in the inverted data RAM accessed by the CPU. This address is incremented each time the inversion RAM is accessed.

RS	D7	D6	D5	D4	D3	D2	D1	D0
1	–	–	–	–	IXA3	IXA2	IXA1	IXA0

Default settings (initial values set by reset command)

D7	D6	D5	D4	D3	D2	D1	D0
–	–	–	–	0	0	0	0

6.19 Inversion Start Line Address Register (R18)

The inversion start line address register specifies the start line address in the display RAM accessed by the CPU when using reverse (inverted) display mode. The range of inverted lines is determined based on the contents of this register and the inversion end line address register.

RS	D7	D6	D5	D4	D3	D2	D1	D0
1	–	ISL6	ISL5	ISL4	ISL3	ISL2	ISL1	ISL0

Default settings (initial values set by reset command)

D7	D6	D5	D4	D3	D2	D1	D0
–	0	0	0	0	0	0	0

6.20 Inversion End Line Address Register (R19)

The inversion end line address register specifies the end line address in the display RAM accessed by the CPU when using reverse (inverted) display mode. The range of inverted lines is determined based on the contents of this register and the inversion start line address register.

RS	D7	D6	D5	D4	D3	D2	D1	D0	Setting
1	–	IEL6	IEL5	IEL4	IEL3	IEL2	IEL1	IEL0	–

Default settings (initial values set by reset command)

D7	D6	D5	D4	D3	D2	D1	D0
–	0	0	0	0	0	0	0

6.21 Inverted Data Memory Access Register (R20)

The inverted data memory access register is used when accessing the inverted data RAM. When this register is accessed, the data is written directly to the inverted data RAM.

When using reset command to reset, the contents of memory are retained.

RS	D7	D6	D5	D4	D3	D2	D1	D0	Setting
1	D7	D6	D5	D4	D3	D2	D1	D0	–

Data	Status
0	Normal
1	Inverted

Default settings (initial values set by reset command, all data)

D7	D6	D5	D4	D3	D2	D1	D0
0	0	0	0	0	0	0	0

6.22 Partial Start Line Address Register (R21)

The partial start line address register specifies the start line address in the display RAM accessed by the CPU when using partial display mode. The partial display area is determined as the number of lines specified in the partial display mode setting register (R10), starting from this start line address.

RS	D7	D6	D5	D4	D3	D2	D1	D0	Setting
1	–	PSL6	PSL5	PSL4	PSL3	PSL2	PSL1	PSL0	–

Default settings (initial values set by reset command)

D7	D6	D5	D4	D3	D2	D1	D0
–	0	0	0	0	0	0	0

6.23 Gray Scale Data Registers 1 to 4 (R23 to R26)

The gray scale data registers specify the gray scale level when using normal four-level gray scale display mode. Use of this register optimizes the gray scale display.

Rx	Data	RS	D7	D6	D5	D4	D3	D2	D1	D0	Setting
R23	0, 0	1	–	–	GD5	GD4	GD3	GD2	GD1	GD0	–
R24	0, 1	1	–	–	GD5	GD4	GD3	GD2	GD1	GD0	–
R25	1, 0	1	–	–	GD5	GD4	GD3	GD2	GD1	GD0	–
R26	1, 1	1	–	–	GD5	GD4	GD3	GD2	GD1	GD0	–

D7	D6	D5	D4	D3	D2	D1	D0	Gray scale level
Disable	Disable	0	0	0	0	0	0	Level 0
Disable	Disable	0	0	0	0	0	1	Level 1
Disable	Disable	0	0	0	0	1	0	Level 2
Disable	Disable	0	0	0	0	1	1	Level 3
			:					:
Disable	Disable	0	1	1	1	1	1	Level 31
Disable	Disable	1	0	0	0	0	0	Level 32

Default settings (initial values set by reset command, for all gray scale data registers)

D7	D6	D5	D4	D3	D2	D1	D0
–	–	0	0	0	0	0	0

6.24 Partial Gray Scale Data Registers 1 to 4 (R27 to R30)

The partial gray scale data registers specify the gray scale level when using partial four-level gray scale display mode. Use of this register optimizes the gray scale display.

Rx	Data	RS	D7	D6	D5	D4	D3	D2	D1	D0	Setting
R27	0, 0	1	–	–	PGD5	PGD4	PGD3	PGD2	PGD1	PGD0	–
R28	0, 1	1	–	–	PGD5	PGD4	PGD3	PGD2	PGD1	PGD0	–
R29	1, 0	1	–	–	PGD5	PGD4	PGD3	PGD2	PGD1	PGD0	–
R30	1, 1	1	–	–	PGD5	PGD4	PGD3	PGD2	PGD1	PGD0	–

D7	D6	D5	D4	D3	D2	D1	D0	Gray scale level
Disable	Disable	0	0	0	0	0	0	Level 0
Disable	Disable	0	0	0	0	0	1	Level 1
Disable	Disable	0	0	0	0	1	0	Level 2
Disable	Disable	0	0	0	0	1	1	Level 3
			:					:
Disable	Disable	0	1	1	1	1	1	Level 31
Disable	Disable	1	0	0	0	0	0	Level 32

Default settings (initial values set by reset command, for all partial gray scale data registers)

D7	D6	D5	D4	D3	D2	D1	D0
–	–	0	0	0	0	0	0

6.25 Power System Control Register 1 (R32)

This command sets the μPD16498's power system mode.

RS	E /RD	R,/W /WR	D7	D6	D5	D4	D3	D2	D1	D0
1	1	0	HPM1	HPM0	–	TCS2	TCS1	OP2	OP1	OP0

Flag	Function
HPM1, HPM0	These flags set the driver mode as shown in Table 6-9.
TCS1, TCS0	These flags set the value for selecting the V _{REG} voltage's temperature curve, as shown in Table 6-10.
OP2 to OP0	These flags control the booster's ON/OFF status, the voltage regulator (V regulator) and voltage follower (V/F). The functions controlled via these three bits by the power control setting command are listed in Table 6-11.

Table 6-9. Driver Mode Setting

HPM1	HPM0	Mode Setting
0	0	Normal mode
0	1	Low-power mode
1	0	High-power mode
1	1	Power activation mode

Table 6-10. Selection V_{REG} Voltage's Temperature Curve Value

TCS1	TCS0	Temperature gradient (%/°C)	V _{REG} (TYP.) (V)
0	0	-0.06	1.04
0	1	-0.08	0.98
1	0	-0.09	0.93
1	1	-0.12	0.85

Table 6-11. Detailed Description of Functions Controlled by Flags of Power System Control 1

Item		Status	
		1	0
OP2	Booster control flag	ON	OFF
OP1	V regulator control flag	ON	OFF
OP0	Voltage follower control flag	ON	OFF

Default settings (initial values set by reset command)

D7	D6	D5	D4	D3	D2	D1	D0
0	0	–	0	0	1	1	1

6.26 Power System Control Register 2 (R33)

This command is used to control the on-chip register for V_{LCD} voltage regulation.

RS	E /RD	R,/W /WR	D7	D6	D5	D4	D3	D2	D1	D0	Setting
1	1	0	–	VRR2	VRR1	VRR0	–	PVR2	PVR1	PVR0	–

Flag	Function
VRR2 to VRR0	When using normal display mode, power system control 2 (V _{LCD} regulator resistance factor setting command) can be used to change the resistance factor at 8 levels. The three flags in power system control 2 set the values shown in Table 6-12 as reference values for (1 + Rb/Ra).
PVR2 to PVR0	When using partial display mode, power system control 2 (V _{LCD} regulator resistance factor setting command) can be used to change the resistance factor at 8 levels. The three flags in power system control 2 set the values shown in Table 6-12 as reference values for (1 + Rb/Ra).

Table 6-12. Reference Values for V_{LCD} Internal Resistance Factor Regulator Register

Register			1+Rb/Ra
VRR2	VRR1	VRR0	
PVR2	PVR1	PVR0	
0	0	0	5
0	0	1	8
0	1	0	12
0	1	1	13
1	0	0	16
1	0	1	19
1	1	0	21
1	1	1	24

Default settings (initial values set by reset command)

D7	D6	D5	D4	D3	D2	D1	D0
–	0	0	0	–	0	0	0

6.27 Power System Control Register 3 (R34)

This command sets the power system mode, including the bias setting for the μPD16498's normal display mode and the number of boost levels for partial display mode.

RS	D7	D6	D5	D4	D3	D2	D1	D0	Setting
1	BIS2	BIS1	BIS0	FBS2	FBS1	FBS0	BST1	BST0	–

Flag	Function			
BIS2 to BIS0 ^{Note}	These three flags select the bias ratio as shown below.			
	BIS2	BIS1	BIS0	Bias ratio
	0	0	0	1/12 bias
	0	0	1	1/11 bias
	0	1	0	1/10 bias
	0	1	1	1/9 bias
	1	0	0	1/8 bias
	1	0	1	1/7 bias
	1	1	0	Prohibited
	1	1	1	Prohibited
When partial display mode is set, the bias ratio set by the partial mode setting is automatically selected.				
FBS2 to FBS0 ^{Note}	The number of boost levels in booster for normal display mode is selected as shown below.			
	FBS2	FBS1	FBS0	Boost level
	0	0	0	x4
	0	0	1	x5
	0	1	0	x6
	0	1	1	x7
	1	0	0	x8
	1	0	1	x9
	1	1	0	Prohibited
1	1	1	Prohibited	
BST1, BST0	The number of boost levels in the booster for partial display mode is selected as shown below.			
	BST1	BST0	Boost level	
	0	0	x2	
	0	1	x3	
	1	0	x4	
1	1	Prohibited		

Note Be sure to execute the HALT command before changing these flag settings.

Default settings (initial values set by reset command)

D7	D6	D5	D4	D3	D2	D1	D0
0	0	0	0	0	0	0	0

6.28 Electronic Volume Register (R35)

The electronic volume register specifies the electronic volume value for adjusting the contrast when using normal display mode. Any value among 256 steps can be selected.

RS	D7	D6	D5	D4	D3	D2	D1	D0	Setting
1	EV7	EV6	EV5	EV4	EV3	EV2	EV1	EV0	–

Default settings (initial values set by reset command)

D7	D6	D5	D4	D3	D2	D1	D0
0	0	0	0	0	0	0	0

6.29 Partial Electronic Volume Register (R36)

The partial electronic volume register specifies the electronic volume value for adjusting the contrast when using partial display mode. Any value among 256 steps can be selected.

RS	D7	D6	D5	D4	D3	D2	D1	D0	Setting
1	PEV7	PEV6	PEV5	PEV4	PEV3	PEV2	PEV1	PEV0	–

Default settings (initial values set by reset command)

D7	D6	D5	D4	D3	D2	D1	D0
0	0	0	0	0	0	0	0

6.30 Boost Adjustment Register (R37)

The voltage (range: 1/8 V_{DD2} to 7/8 V_{DD2}) set to this register is applied to the boost level set for the booster.

RS	D7	D6	D5	D4	D3	D2	D1	D0	Setting
1	–	–	–	–	–	DDC2	DDC1	DDC0	–

Table 6-13. Boost Adjustment Register (R37) Settings

DDC2	DDC1	DDC0	Boost Adjustment Voltage
0	0	0	Regulator Circuit Stopped
0	0	1	1/8 V _{DD2}
0	1	0	2/8 V _{DD2}
0	1	1	3/8 V _{DD2}
1	0	0	4/8 V _{DD2}
1	0	1	5/8 V _{DD2}
1	1	0	6/8 V _{DD2}
1	1	1	7/8 V _{DD2}

Default settings (initial values set by reset command)

D7	D6	D5	D4	D3	D2	D1	D0
–	–	–	–	–	0	0	0

6.31 Static Icon Address Register (R40)

The static icon address specifies the address in the static icon data RAM accessed by the CPU. This address is automatically incremented each time the static icon data RAM is accessed.

RS	D7	D6	D5	D4	D3	D2	D1	D0
1	-	-	-	-	-	SIA2	SIA1	SIA0

Default settings (initial values set by reset command)

D7	D6	D5	D4	D3	D2	D1	D0
-	-	-	-	-	0	0	0

6.32 Static Icon Memory Access Register (R41)

The static icon memory access register is used when accessing the static icon data RAM. When this register is write-accessed, the data is written directly to the static icon data RAM.

When using reset command to reset, the contents of this register are retained.

RS	D7	D6	D5	D4	D3	D2	D1	D0
1	D7	D6	D5	D4	D3	D2	D1	D0

Default settings (initial values set by reset command)

D7	D6	D5	D4	D3	D2	D1	D0
-	-	-	-	-	-	-	-

6.33 Static Icon Contrast Register (R42)

The static icon contrast adjusts the contrast of static icons using phase modulation.

The pulse width of the ON signal that is output in static drive mode is divided into 32 levels (1/32 to 32/32 pulse width) and the dot output's timing changes during output according to the phase modulation ratio recorded in bits ICS4 to ICS0 of the static icon contrast (R42), as is shown in Table 6-14.

RS	D7	D6	D5	D4	D3	D2	D1	D0
1	-	-	-	0	ICS3	ICS2	ICS1	ICS0

Table 6-14. Static Icon Contrast Register (R42) Setting

ICS4	ICS3	ICS2	ICS1	ICS0	Phase Modulation Ratio
0	0	0	0	0	0/32
0	0	0	0	1	1/32
0	0	0	1	0	2/32
0	0	0	1	1	3/32
		:			:
1	1	1	0	1	29/32
1	1	1	1	0	30/32
1	1	1	1	1	31/32

Default settings (initial values set by reset command)

D7	D6	D5	D4	D3	D2	D1	D0
-	-	-	-	0	0	0	0

6.34 RAM Test Mode Setting Register (R44)

The RAM test mode setting register directly writes the data for each type of display mode to the display RAM, as shown in Table 6-15.

RS	D7	D6	D5	D4	D3	D2	D1	D0
1	–	–	–	–	RTS3	RTS2	RTS1	RTS0

Table 6-15. RAM Test Mode Setting Register (R44) Setting

RTS3	RTS2	RTS1	RTS0	Write Data
0	0	0	0	Normal operation
0	1	0	0	Displays list of gray scales
1	0	0	0	all 00/pixel
1	0	0	1	all 11/pixel
1	0	1	0	Checker pattern: 00/11
1	0	1	1	Checker pattern: 11/00
1	1	0	0	Checker pattern: 01/10
1	1	0	1	Checker pattern: 10/01
1	1	1	0	Vertical striped pattern: 00/11
1	1	1	1	Horizontal striped pattern: 00/11

Default settings (initial values set by reset command)

D7	D6	D5	D4	D3	D2	D1	D0
–	–	–	–	0	0	0	0

6.35 Signature Read Register (R45)

This command is used to read the IC signature set via the SIGIN1 and SIGIN2 pins. This is a read-only register.

RS	D7	D6	D5	D4	D3	D2	D1	D0
1	–	–	–	–	–	–	SIGIN2	SIGIN1

Default settings (initial values set by reset command)

D7	D6	D5	D4	D3	D2	D1	D0
–	–	–	–	–	–	–	–

7. LIST OF μPD16498 REGISTERS

CS		Index Register							R/W	Data Bits									
	RS	5	4	3	2	1	0	7		6	5	4	3	2	1	0			
1																			
0	0							IR	Index Register	W			IR5	IR4	IR3	IR2	IR1	IR0	
0	1	0	0	0	0	0	0	R0	Control register 1	R/W	RMW	DISP	STBY	BLD	IVD	HALT	ADC	COMR	
0	1	0	0	0	0	0	1	R1	Control register 2	R/W	FDM	IBL	IDIS	DSEL	BWW	GRAY	DTY	INC	
0	1	0	0	0	0	1	0	R2	Reset command	W								CRES	
0	1	0	0	0	0	1	1	R3	X address register	R/W				XA4	XA3	XA2	XA1	XA0	
0	1	0	0	0	1	0	0	R4	Y address register	R/W			YA6	YA4	YA3	YA2	YA1	YA0	
0	1	0	0	0	1	0	1	R5	Duty setting register	R/W		DT6	DT5	DT4	DT3	DT2	DT1	DT0	
0	1	0	0	0	1	1	0	R6	AC driver inversion cycle register	R/W			NID6	NID5	NID4	NID3	NID2	NID1	NID0
0	1	0	0	0	1	1	1	R7	AC driver inversion position shift register	W			MSD6	MSD5	MSD4	MSD3	MSD2	MSD1	MSD0
0	1	0	0	1	0	0	0	R8	Partial AC driver inversion cycle register	W				PID4	PID3	PID2	PID1	PID0	
0	1	0	0	1	0	0	1	R9	Partial AC driver inversion potision shift register	W				PSD4	PSD3	PSD2	PSD1	PSD0	
0	1	0	0	1	0	1	0	R10	Partial display mode setting register	R/W					PBIS		PDT1	PDT0	
0	1	0	0	1	0	1	1	R11	Display memory access register	R/W	D7	D6	D5	D4	D3	D2	D1	D0	
0	1	0	0	1	1	0	0	R12	Display start line setting register	W		DSL6	DSL5	DSL4	DSL3	DSL2	DSL1	DSL0	
0	1	0	0	1	1	0	1	R13	Blink X address register	R/W				BXA3	BXA2	BXA1	BXA0		
0	1	0	0	1	1	1	0	R14	Blink start line address register	R/W			BSL6	BSL5	BSL4	BSL3	BSL2	BSL1	BSL0
0	1	0	0	1	1	1	1	R15	Blink end line address register	R/W			BEL6	BEL5	BEL4	BEL3	BEL2	BEL1	BEL0
0	1	0	1	0	0	0	0	R16	Blink data memory access register	R/W	D7	D6	D5	D4	D3	D2	D1	D0	
0	1	0	1	0	0	0	1	R17	Inverted X address register	R/W				IXA3	IXA2	IXA1	IXA0		
0	1	0	1	0	0	1	0	R18	Inversion start line address register	R/W			ISL6	ISL5	ISL4	ISL3	ISL2	ISL1	ISL0
0	1	0	1	0	0	1	1	R19	Inversion end line address register	R/W			IEL6	IEL5	IEL4	IEL3	IEL2	IEL1	IEL0
0	1	0	1	0	1	0	0	R20	Inverted data memory access register	R/W	D7	D6	D5	D4	D3	D2	D1	D0	
0	1	0	1	0	1	0	1	R21	Partial start line address register	W			PSL6	PSL5	PSL4	PSL3	PSL2	PSL1	PSL0
0	1	0	1	0	1	1	0	R22											
0	1	0	1	0	1	1	1	R23	Gray scale data register 1 (0, 0)	W				GD5	GD4	GD3	GD2	GD1	GD0
0	1	0	1	1	0	0	0	R24	Gray scale data register 2 (0, 1)	W				GD5	GD4	GD3	GD2	GD1	GD0
0	1	0	1	1	0	0	1	R25	Gray scale data register 3 (1, 0)	W				GD5	GD4	GD3	GD2	GD1	GD0
0	1	0	1	1	0	1	0	R26	Gray scale data register 4 (1, 1)	W				GD5	GD4	GD3	GD2	GD1	GD0
0	1	0	1	1	0	1	1	R27	Patial gray scale data register 1 (0, 0)	W				PGD5	PGD4	PGD3	PGD2	PGD1	PGD0
0	1	0	1	1	1	0	0	R28	Patial gray scale data register 2 (0, 1)	W				PGD5	PGD4	PGD3	PGD2	PGD1	PGD0
0	1	0	1	1	1	0	1	R29	Patial gray scale data register 3 (1, 0)	W				PGD5	PGD4	PGD3	PGD2	PGD1	PGD0
0	1	0	1	1	1	1	0	R30	Patial gray scale data register 4 (1, 1)	W				PGD5	PGD4	PGD3	PGD2	PGD1	PGD0
0	1	0	1	1	1	1	1	R31											
0	1	1	0	0	0	0	0	R32	Power system control register 1	W	HPM1	HPM0		TCS1	TSC0	OP2	OP1	OP0	
0	1	1	0	0	0	0	1	R33	Power system control register 2	W		VRR2	VRR1	VRR0		PVR2	PVR1	PVR0	
0	1	1	0	0	0	1	0	R34	Power system control register 3	W	BIS2	BIS1	BIS0	FBS2	FBS1	FBS0	BST1	BST0	
0	1	1	0	0	0	1	1	R35	Electronic volume register	W	EV7	EV6	EV5	EV4	EV3	EV2	EV1	EV0	
0	1	1	0	0	1	0	0	R36	Partial electronic volume register	W	PEV7	PEV6	PEV5	PEV4	PEV3	PEV2	PEV1	PEV0	
0	1	1	0	0	1	0	1	R37	Boost adjustment register	W							DDC2	DDC1	DDC0
0	1	1	0	0	1	1	0	R38											
0	1	1	0	0	1	1	1	R39											
0	1	1	0	1	0	0	0	R40	Static icon address register	W						SIA2	SIA1	SIA0	
0	1	1	0	1	0	0	1	R41	Static icon memory access register	R/W	D7	D6	D5	D4	D3	D2	D1	D0	
0	1	1	0	1	0	1	0	R42	Static icon contrast register	W				ICS4	ICS3	ICS2	ICS1	ICS0	
0	1	1	0	1	0	1	1	R43											
0	1	1	0	1	1	0	0	R44	RAM test mode setting register	W					RTS3	RTS2	RTS1	RTS0	
0	1	1	0	1	1	0	1	R45	Signature read register	R							SIG2	SIG1	
0	1	1	0	1	1	1	0	R46											
0	1	1	0	1	1	1	1	R47											
0	1	1	1	0	0	0	0	R48											
0	1	1	1	0	0	0	1	R49											
0	1	1	1	0	0	1	0	R50											
0	1	1	1	0	0	1	1	R51											
0	1	1	1	0	1	0	0	R52											
0	1	1	1	0	1	0	1	R53											
0	1	1	1	0	1	1	0	R54											
0	1	1	1	0	1	1	1	R55											
0	1	1	1	1	0	0	0	R56											
0	1	1	1	1	0	0	1	R57											
0	1	1	1	1	0	1	0	R58											
0	1	1	1	1	0	1	1	R59											
0	1	1	1	1	1	0	0	R60											
0	1	1	1	1	1	0	1	R61											
0	1	1	1	1	1	1	0	R62											
0	1	1	1	1	1	1	1	R63											

Remark [shaded]: Not to use these registers.

8. POWER SUPPLY SEQUENCE

The μPD16498 includes power supply circuitry, such as a booster and a voltage follower. When a reset is performed using the /RES pin, the reset function is restricted so as to prevent operation faults that may occur due to noise effects, etc.

When electric charge remains in the smoothing capacitor that is connected between the V_{SS} pin and the voltage pins related to the LCD driver (V_{LCD}, V_{LC1} to V_{LC4}), troubles such as a brief all-black display screen may occur when the power is switched ON or OFF. The following power-on sequence is recommended as a means to avoid such troubles when switching the power ON or OFF.

8.1 Power ON Sequence (When Using On-Chip Power Supply, Power Supply ON → Display ON)

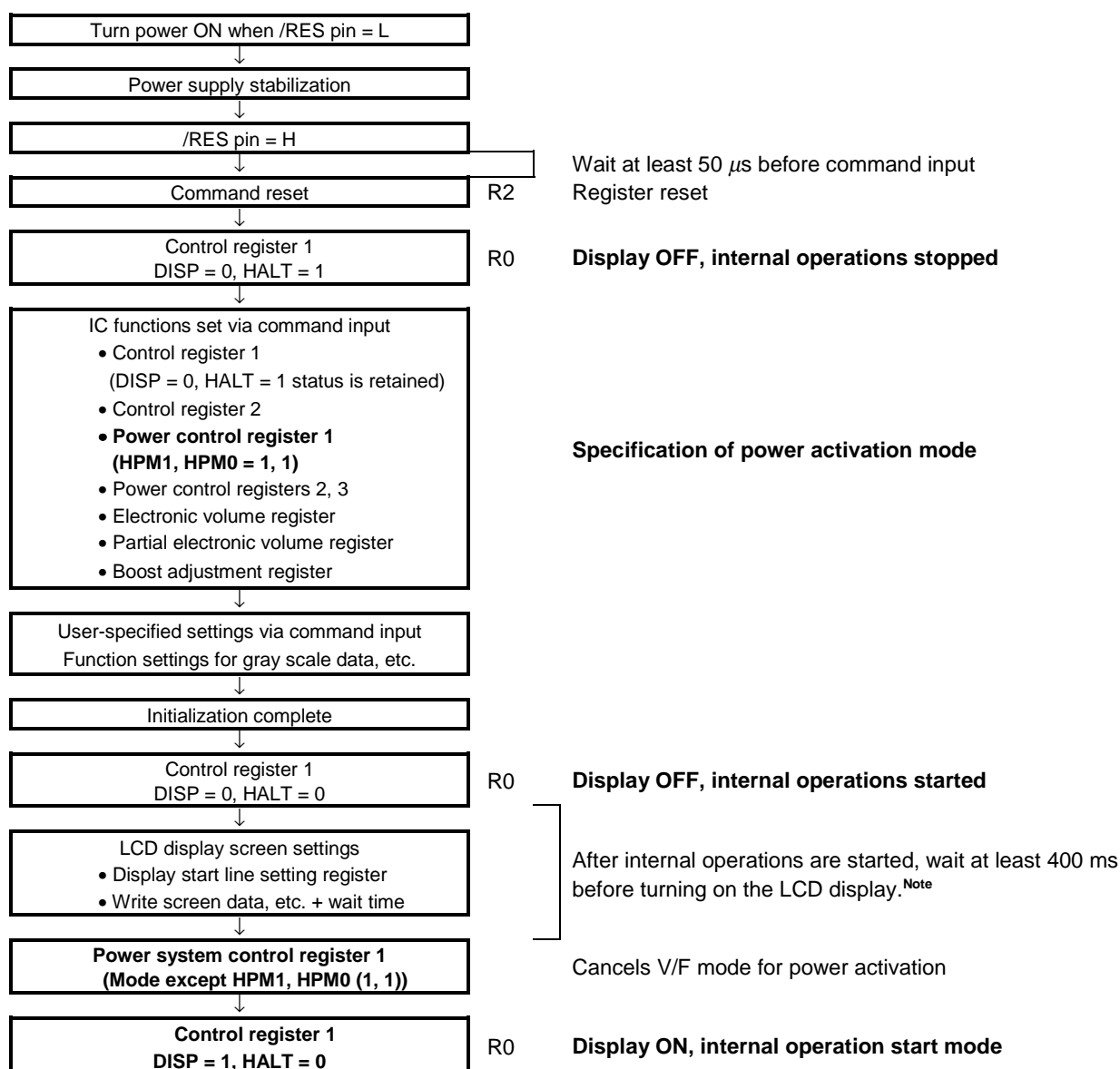

Note This 400 ms wait time varies according to the panel characteristics and the capacitance value of the boost/smoothing capacitor. We recommend determining the wait time after making a thorough evaluation of the actual device (refer to **8.5 V_{OUT}, V_{LCD} Voltage Sequence (Power ON → Power OFF)**).

8.2 Power OFF Sequence (When Using On-Chip Power Supply)

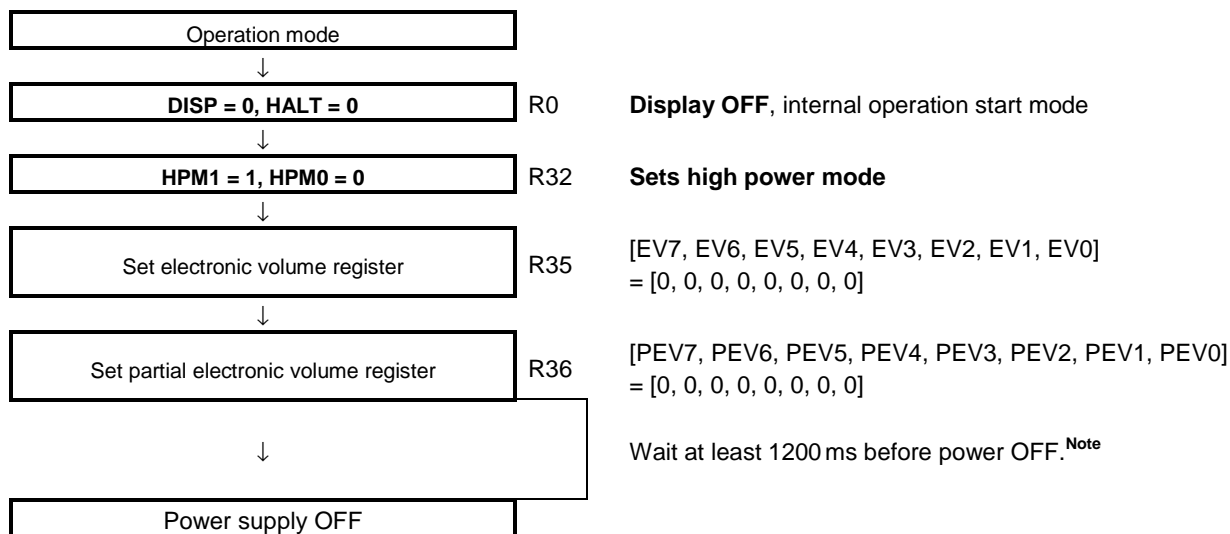

Note This 1200 ms wait time varies according to the panel characteristics and the capacitance value of the boost/smoothing capacitor. NEC recommends determining the wait time after making a thorough evaluation of the actual device (refer to 8.5 **V_{OUT}, V_{LCD} Voltage Sequence (power ON → power OFF)**).

8.3 Power ON Sequence (When Using External Driver Power Supply, Power ON → Display ON)

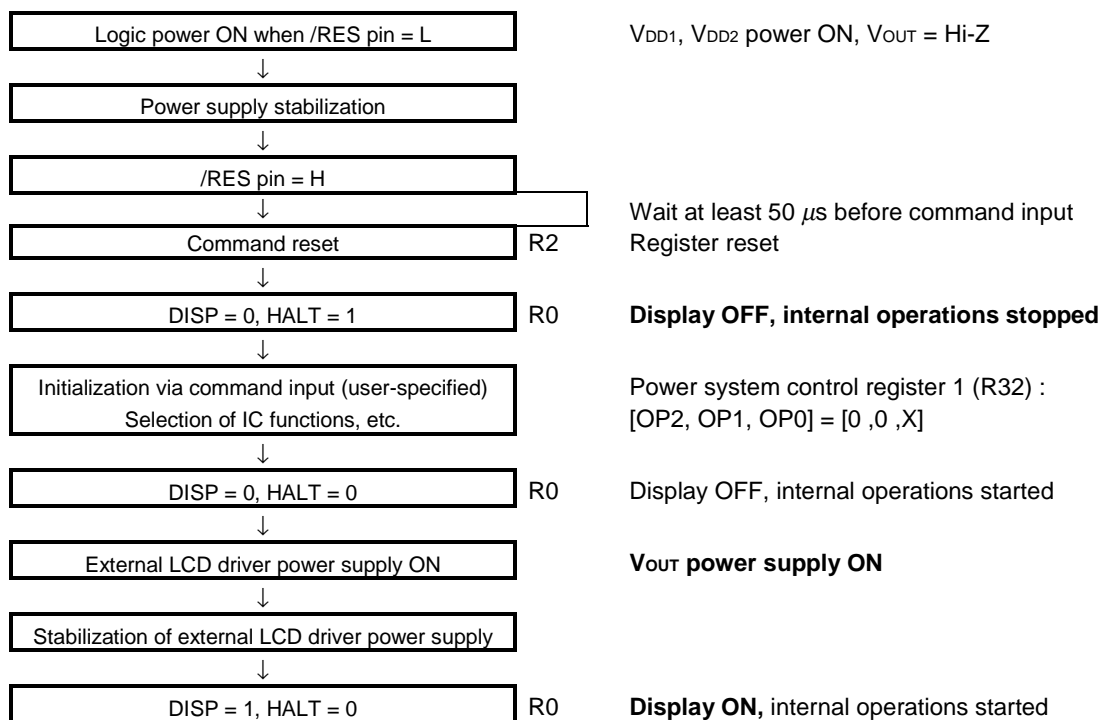

8.4 Power Supply OFF Sequence (When Using External Driver Power Supply)

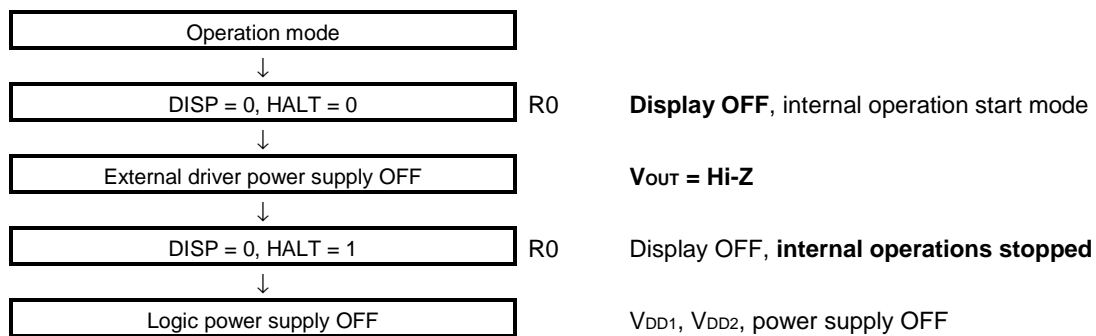

8.5 V_{OUT}, V_{LCD} Voltage Sequence (Power ON → Power OFF)

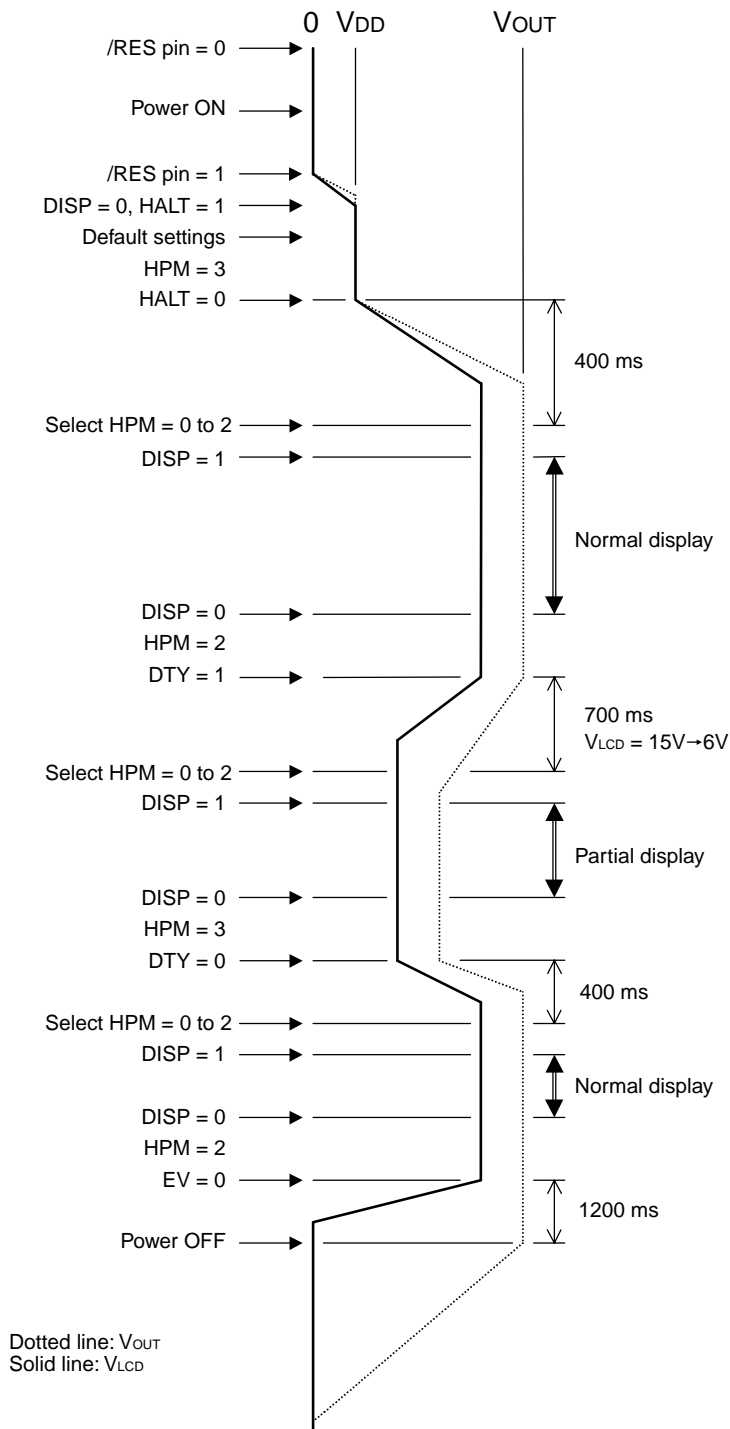

Conditions:

V_{DD}: V_{DD1} = V_{DD2} = 3.0 V

Boost levels: x6 (in normal display mode), x3 (in partial display mode)

Capacitors: V_{LCDn} pin to C_n^{+/−} pin = 1 μF,

AMP_{OUT} pin, AMP_{OUTP} pin, V_{RS} pin = 0.1 μF

Caution Connect a capacitor of less than 0.1 μF to both AMP_{OUT} and AMP_{OUTP} pins.

9. USE OF RAM TEST MODE

The μPD16498 has a test mode for writing nine types of screen data to display RAM. When using the test mode, be sure to execute via the sequence shown below. If executing the test mode by some other sequence, troubles may appear in the screen display.

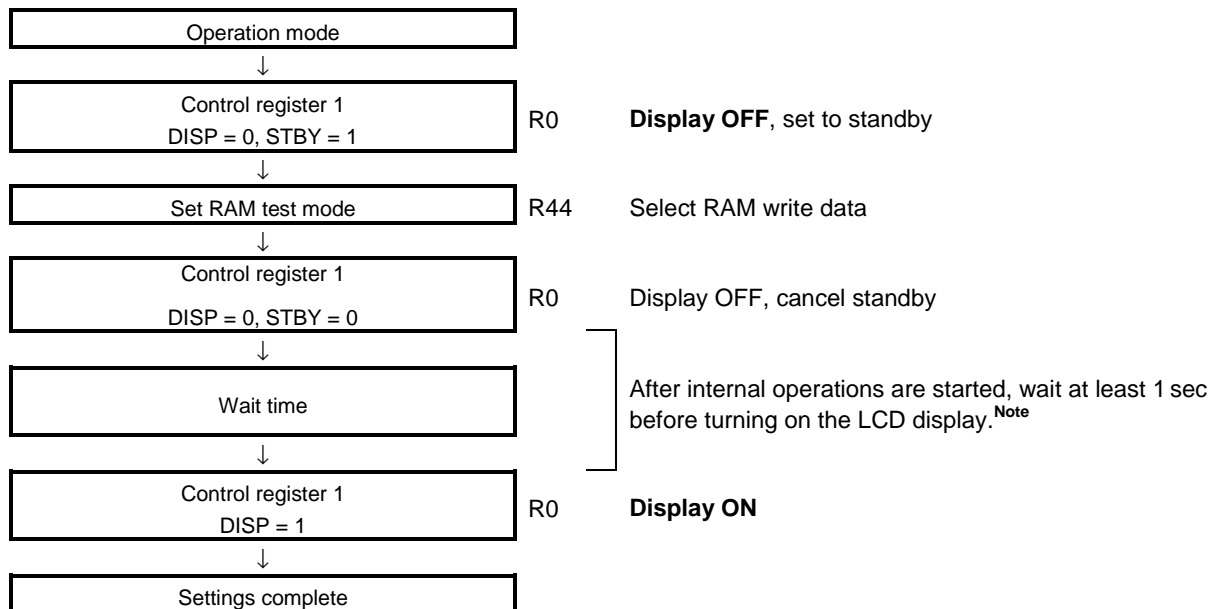

Note This 1 sec wait time varies according to the panel characteristics and the capacitance value of the boost/smoothing capacitor. We recommend determining the wait time after making a thorough evaluation of the actual device.

10. USE OF STANDBY/HALT MODE

The μPD16498 has a standby mode for reducing current consumption, and a HALT mode for switching display mode. Electrical circuits as a DC/DC converter are stopped in standby/HALT mode.

When using the standby/HALT mode, be sure to execute via the sequence shown below. If executing the test mode by some other sequence, troubles may appear in the screen display.

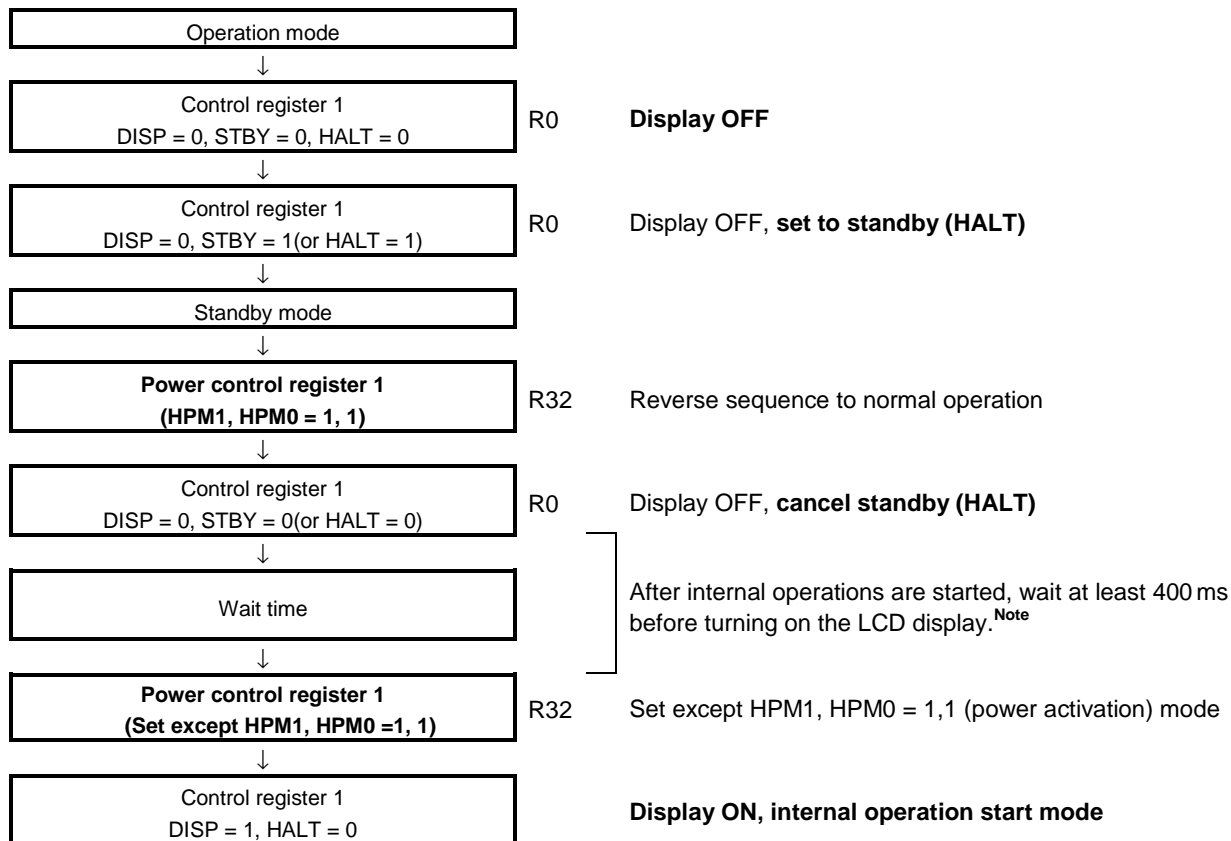

Note This 400 ms wait time varies according to the panel characteristics and the capacitance value of the boost/smoothing capacitor. We recommends determining the wait time after making a thorough evaluation of the actual device.

11. ELECTRICAL SPECIFICATIONS

Absolute Maximum Ratings (T_A = +25°C, V_{SS} = 0 V)

Parameter	Symbol	Ratings	Unit
Logic system supply voltage	V _{DD1}	-0.3 to +4.0	V
Booster supply voltage	V _{DD2}	-0.3 to +4.0	V
Driver supply voltage	V _{OUT}	-0.3 to +20.0	V
Driver reference supply input voltage	V _{LCD} , V _{LC1} to V _{LC4}	-0.3 to V _{OUT} +0.3	V
Logic system input voltage	V _{IN1}	-0.3 to V _{DD1} +0.3	V
Logic system output voltage	V _{OUT1}	-0.3 to V _{DD1} +0.3	V
Logic system input/output voltage	V _{I/O1}	-0.3 to V _{DD1} +0.3	V
Driver system input voltage	V _{IN2}	-0.3 to V _{OUT} +0.3	V
Driver system output voltage	V _{OUT2}	-0.3 to V _{OUT} +0.3	V
Operating ambient temperature	T _A	-40 to +85	°C
Storage temperature	T _{stg}	-55 to +125	°C

Caution Product quality may suffer if the absolute maximum rating is exceeded even momentarily for any parameter. That is, the absolute maximum ratings are rated values at which the product is on the verge of suffering physical damage, and therefore the product must be used under conditions that ensure that the absolute maximum ratings are not exceeded.

Recommended Operating Range

Parameter	Symbol	MIN.	TYP.	MAX.	Unit
Logic system supply voltage	V _{DD1}	1.7		3.6	V
Booster supply voltage	V _{DD2} ^{Note1}	2.4		3.6	V
Driver system supply voltage	V _{OUT} ^{Note2}	5.5		18.0	V
Logic system input voltage	V _{IN}	0		V _{DD1}	V
Driver system supply voltage	V _{LCD} , V _{LC1} to V _{LC4} ^{Note2}	0		V _{OUT}	V
Maximum setting for LCD driver voltage	V _{LCD} ^{Note3}			V _{OUT} -0.5	V

- Notes**
1. V_{DD1} must be less than or equal to V_{DD2}
 2. This item is the recommended parameter when the LCD has an external driver.
 3. This item is the recommended parameter when an on-chip power supply circuit drives the LCD.

Cautions 1. When using an external LCD driver, be sure to maintain these relations:

$$V_{SS} < V_{LC4} < V_{LC3} < V_{LC2} < V_{LC1} < V_{LCD} \leq V_{OUT}$$

2. Maintain the relations shown in 8. POWER SUPPLY SEQUENCE when turning the power ON or OFF.
3. When using an external resistor (when not using an on-chip resistor for V_{LCD} adjustment), maintain supply of a voltage between 1.0 V and the V_{DD1} voltage to the V_R and V_{RS} pins.

Electrical Characteristics 1

(Unless Otherwise Specified, $T_A = -40$ to $+85^\circ\text{C}$, $V_{DD1} = 1.7$ to 3.6 V, $V_{DD2} = 2.4$ to 3.6 V)

Parameter	Symbol	Conditions	MIN.	TYP. ^{Note1}	MAX.	Unit
High-level input voltage	V_{IH}		$0.8 V_{DD1}$			V
Low-level input voltage	V_{IL}				$0.2 V_{DD1}$	V
High-level input current	I_{IH1}	Except for P7 (SI), P6 (SCL) and P5 to P0			1	μA
Low-level input current	I_{IL1}	Except for P7 (SI), P6 (SCL) and P5 to P0			-1	μA
High-level output voltage	V_{OH}	$I_{OUT} = -1$ mA except OSC_{OUT}	$V_{DD1} - 0.5$			V
Low-level output voltage	V_{OL}	$I_{OUT} = 1$ mA except OSC_{OUT}			0.5	V
High-level leakage current	I_{LOH}	P7 (SI), P6 (SCL) and P5 to P0, $V_{IN/OUT} = V_{DD1}$			10	μA
Low-level leakage current	I_{LOL}	P7 (SI), P6 (SCL) and P5 to P0, $V_{IN/OUT} = V_{SS}$			-10	μA
Common output ON resistance	R_{COM}	$V_{LCn} \rightarrow COM_n$, $V_{OUT} = 15$ V, $V_{LCD} = 13$ V, 1/10 bias, $ I_o = 50$ μA			4	kΩ
Segment output ON resistance	R_{SEG}	$V_{LCn} \rightarrow SEG_n$, $V_{OUT} = 15$ V, $V_{LCD} = 13$ V, 1/10 bias, $ I_o = 50$ μA			4	kΩ
Driver voltage (boost voltage)	V_{OUT}	In x5 boost mode, $V_{DD} = 3.0$ V, Checker pattern display	13.8			V
		In x6 boost mode, $V_{DD} = 3.0$ V, Checker pattern display	16.6			V
Reference voltage	V_{REG} ^{Note2}	$V_{DD} = 3.0$ V, $T_A = 85^\circ\text{C}$, TSC1, TSC0 = 1,1 (temperature characteristic curves: $-0.12\%/^\circ\text{C}$)	0.715	0.775	0.835	V
Oscillation frequency	f_{OSC} ^{Note3}	$V_{DD1} = 3.0$ V, $T_A = 25^\circ\text{C}$, 1/38 duty, in B/W mode, $R = 750$ kΩ		36		kHz
		$V_{DD1} = 3.0$ V, $T_A = 25^\circ\text{C}$, 1/38 duty, in B/W mode, $R = 3$ MΩ		10.6		kHz

Notes 1. TYP. values are reference values when $T_A = 25^\circ\text{C}$ (except V_{REG}).

2. The reference voltage values (V_{REG}) when $T_A = 25^\circ\text{C}$ are shown below:

MIN. = 0.770 V, TYP. = 0.845 V, MAX. = 0.920 V

3. The oscillation frequency fluctuates depending on the wiring capacitance to the external resistor for oscillation.

Electrical Characteristics 2

(Unless Otherwise Specified, T_A = -40 to +85°C)

Parameter	Symbol	Conditions	MIN.	TYP. ^{Note}	MAX.	Unit
Current consumption (normal mode)	IDD11	Frame frequency = 70 Hz, B/W all display OFF data output, 1/128 duty, V _{DD1} = V _{DD2} = 3.0 V, in x5 boost mode, V _{LCD} = 13 V		180	290	μA
		Frame frequency = 70 Hz, B/W checker pattern display data output, 1/128 duty, V _{DD1} = V _{DD2} = 3.0 V, in x5 boost mode, V _{LCD} = 13 V		250	390	μA
Current consumption (high-power mode)	IDD12	Frame frequency = 70 Hz, B/W all display OFF data output, 1/128 duty, V _{DD1} = V _{DD2} = 3.0 V, in x5 boost mode, V _{LCD} = 13 V		300	460	μA
		Frame frequency = 70 Hz, B/W checker pattern display data output, 1/128 duty, V _{DD1} = V _{DD2} = 3.0 V, in x5 boost mode, V _{LCD} = 13 V		380	560	μA
Current consumption (low-power mode)	IDD13	Frame frequency = 70 Hz, B/W all display OFF data output, 1/128 duty, V _{DD1} = V _{DD2} = 3.0 V, in x5 boost mode, V _{LCD} = 13 V		135	220	μA
		Frame frequency = 70 Hz, B/W checker pattern display data output, 1/128 duty, V _{DD1} = V _{DD2} = 3.0 V, in x5 boost mode, V _{LCD} = 13 V		210	320	μA
Current consumption (partial display mode)	IDD21	Frame frequency = 70 Hz, B/W all display OFF data output, 1/38 duty, V _{DD1} = V _{DD2} = 3.0 V, in x3 boost mode, V _{LCD} = 7.0 V, normal mode		95	140	μA
		Frame frequency = 70 Hz, B/W checker pattern display data output, 1/38 duty, V _{DD1} = V _{DD2} = 3.0 V, V _{LCD} = 7.0 V, in x3 boost mode, normal mode		105	160	μA
Current consumption (standby mode)	IDD22	V _{DD1} = V _{DD2} = 3.0 V			10	μA
Current consumption (display icon)	IDD23	Icon frame frequency = 125 Hz, B/W all display OFF data output, V _{DD1} = 3.0 V		18	35	μA

Note TYP. values are reference values when T_A = 25°C.

Required Timing Conditions (Unless Otherwise Specified, T_A = -30 to +85°C)

(1) i80 CPU interface

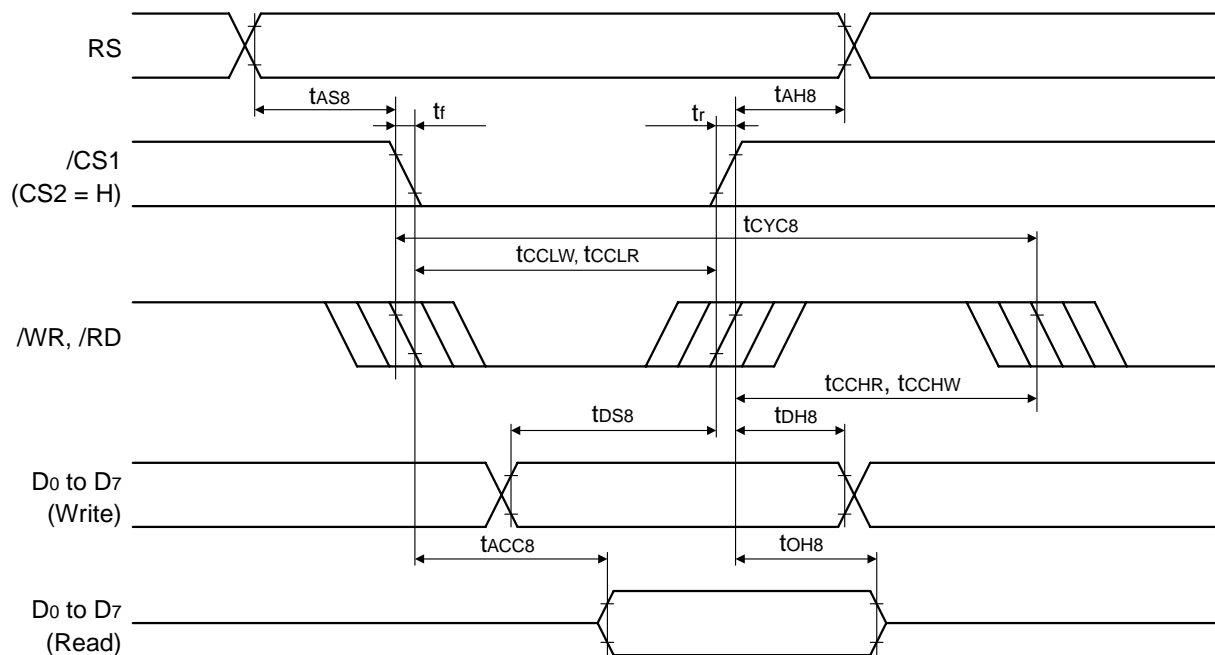

When V_{DD1} = 1.7 V to 2.0 V

Parameter	Symbol	Conditions	MIN.	TYP. ^{Note}	MAX.	Unit
Address hold time	t _{AH8}	RS	0			ns
Address setup time	t _{AS8}	RS	0			ns
System cycle time	t _{CYC8}		1000			ns
Control low-level pulse width (/WR)	t _{CCLW}	/WR	160			ns
Control low-level pulse width (/RD)	t _{CCLR}	/RD	430			ns
Control high-level pulse width (/WR)	t _{CCHW}	/WR	160			ns
Control high-level pulse width (/RD)	t _{CCHR}	/RD	160			ns
Data setup time	t _{DS8}	D0 to D7	160			ns
Data hold time	t _{DH8}	D0 to D7	0			ns
/RD access time	t _{ACC8}	D0 to D7, C _L = 100 pF	0		470	ns
Output disable time	t _{OH8}	D0 to D7, C _L = 5 pF, R = 3 kΩ	0		170	ns

Note TYP. values are reference values when T_A = 25°C.

When V_{DD1} = 2.0 to 2.5 V

Parameter	Symbol	Conditions	MIN.	TYP. ^{Note}	MAX.	Unit
Address hold time	t _{AH8}	RS	0			ns
Address setup time	t _{AS8}	RS	0			ns
System cycle time	t _{CYC8}		600			ns
Control low-level pulse width (/WR)	t _{CCLW}	/WR	120			ns
Control low-level pulse width (/RD)	t _{CCLR}	/RD	240			ns
Control high-level pulse width (/WR)	t _{CCHW}	/WR	120			ns
Control high-level pulse width (/RD)	t _{CCHR}	/RD	120			ns
Data setup time	t _{DS8}	D ₀ to D ₇	120			ns
Data hold time	t _{DH8}	D ₀ to D ₇	0			ns
/RD access time	t _{ACC8}	D ₀ to D ₇ , C _L = 100 pF	0		280	ns
Output disable time	t _{OH8}	D ₀ to D ₇ , C _L = 5 pF, R = 3 kΩ	0		170	ns

Note TYP. values are reference values when T_A = 25°C.

When V_{DD1} = 2.5 to 3.6 V

Parameter	Symbol	Conditions	MIN.	TYP. ^{Note}	MAX.	Unit
Address hold time	t _{AH8}	RS	0			ns
Address setup time	t _{AS8}	RS	0			ns
System cycle time	t _{CYC8}		250			ns
Control low-level pulse width (/WR)	t _{CCLW}	/WR	60			ns
Control low-level pulse width (/RD)	t _{CCLR}	/RD	120			ns
Control high-level pulse width (/WR)	t _{CCHW}	/WR	60			ns
Control high-level pulse width (/RD)	t _{CCHR}	/RD	60			ns
Data setup time	t _{DS8}	D ₀ to D ₇	60			ns
Data hold time	t _{DH8}	D ₀ to D ₇	0			ns
/RD access time	t _{ACC8}	D ₀ to D ₇ , C _L = 100 pF	0		140	ns
Output disable time	t _{OH8}	D ₀ to D ₅ , C _L = 5 pF, R = 3 kΩ	0		70	ns

Note TYP. values are reference values when T_A = 25°C.

Cautions 1. The rise and fall times of input signal (t_r and t_f) are rated as 15 ns or less.

2. All timing is rated based on 20% or 80% of V_{DD1}.

(2) M68 CPU interface

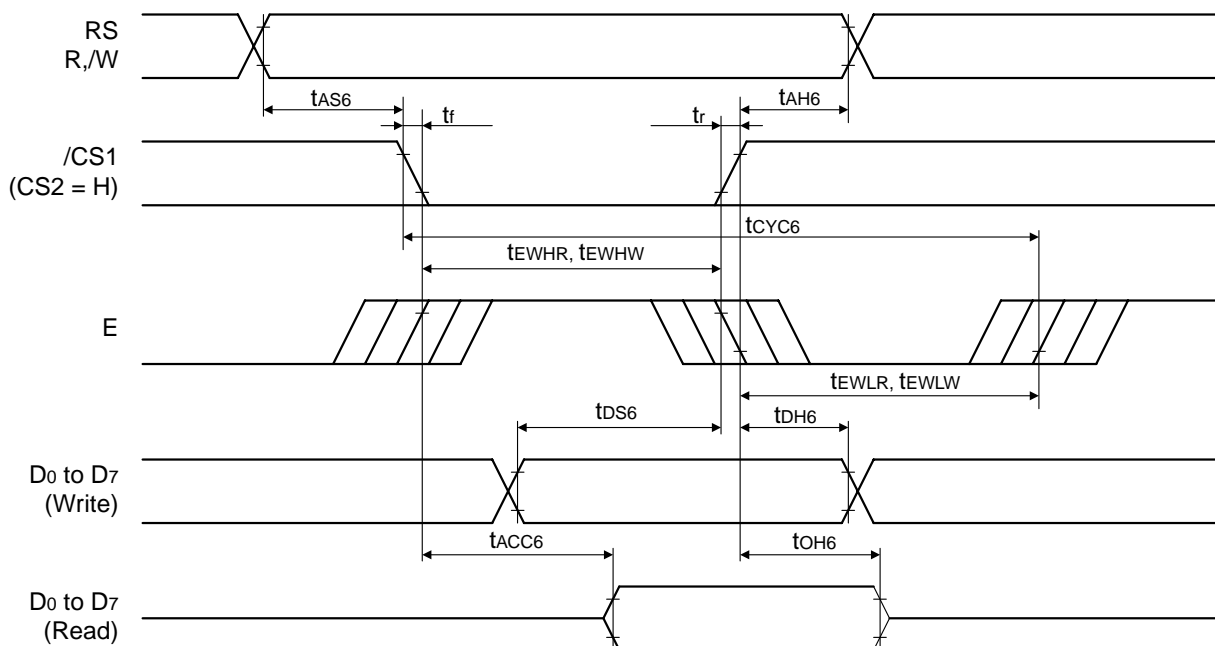

When $V_{DD1} = 1.7$ to 2.0 V

Parameter	Symbol	Conditions	MIN.	TYP. ^{Note}	MAX.	Unit
Address hold time	t_{AH6}	RS	0			ns
Address setup time	t_{AS6}	RS	0			ns
System cycle time	t_{CYC6}		1000			ns
Data setup time	t_{DS6}	D0 to D7	160			ns
Data hold time	t_{DH6}	D0 to D7	0			ns
Access time	t_{ACC6}	D0 to D7, $C_L = 100$ pF	0		470	ns
Output disable time	t_{OH6}	D0 to D7, $C_L = 5$ pF, $R = 3$ kΩ	0		170	ns
Enable high pulse width	Read	t_{EWHR}	E	430		ns
	Write	t_{EWHW}	E	160		ns
Enable low pulse width	Read	t_{EWLR}	E	160		ns
	Write	t_{EWLW}	E	160		ns

Note TYP. values are reference values when $T_A = 25^\circ\text{C}$.

When V_{DD1} = 2.0 to 2.5 V

Parameter	Symbol	Conditions	MIN.	TYP. ^{Note}	MAX.	Unit
Address hold time	t _{AH6}	RS	0			ns
Address setup time	t _{AS6}	RS	0			ns
System cycle time	t _{CYC6}		600			ns
Data setup time	t _{DS6}	D ₀ to D ₇	120			ns
Data hold time	t _{DH6}	D ₀ to D ₇	0			ns
Access time	t _{ACC6}	D ₀ to D ₇ , C _L = 100 pF	0		280	ns
Output disable time	t _{OH6}	D ₀ to D ₇ , C _L = 5 pF, R = 3 kΩ	0		170	ns
Enable high pulse width	Read	t _{EWHR}	E	240		ns
	Write	t _{EWHW}	E	120		ns
Enable low pulse width	Read	t _{EWLR}	E	120		ns
	Write	t _{EWLW}	E	120		ns

Note TYP. values are reference values when T_A = 25°C.

When V_{DD1} = 2.5 to 3.6 V

Parameter	Symbol	Conditions	MIN.	TYP. ^{Note}	MAX.	Unit
Address hold time	t _{AH6}	RS	0			ns
Address setup time	t _{AS6}	RS	0			ns
System cycle time	t _{CYC6}		250			ns
Data setup time	t _{DS6}	D ₀ to D ₇	60			ns
Data hold time	t _{DH6}	D ₀ to D ₇	0			ns
Access time	t _{ACC6}	D ₀ to D ₇ , C _L = 100 pF	0		140	ns
Output disable time	t _{OH6}	D ₀ to D ₇ , C _L = 5 pF, R = 3 kΩ	0		70	ns
Enable high pulse width	Read	t _{EWHR}	E	120		ns
	Write	t _{EWHW}	E	60		ns
Enable low pulse width	Read	t _{EWLR}	E	60		ns
	Write	t _{EWLW}	E	60		ns

Note TYP. values are reference values when T_A = 25°C.

- Cautions**
1. The rise and fall times of input signals (t_r and t_f) are rated at 15 ns or less. When using a fast system cycle time, the rated value range is either (t_r + t_f) ≤ (t_{CYC6} - t_{EWLW} - t_{EWHW}) or (t_r + t_f) ≤ (t_{CYC6} - t_{EWLR} - t_{EWHR}).
 2. All timing is rated based on 20% or 80% of V_{DD1}.

(3) Serial interface

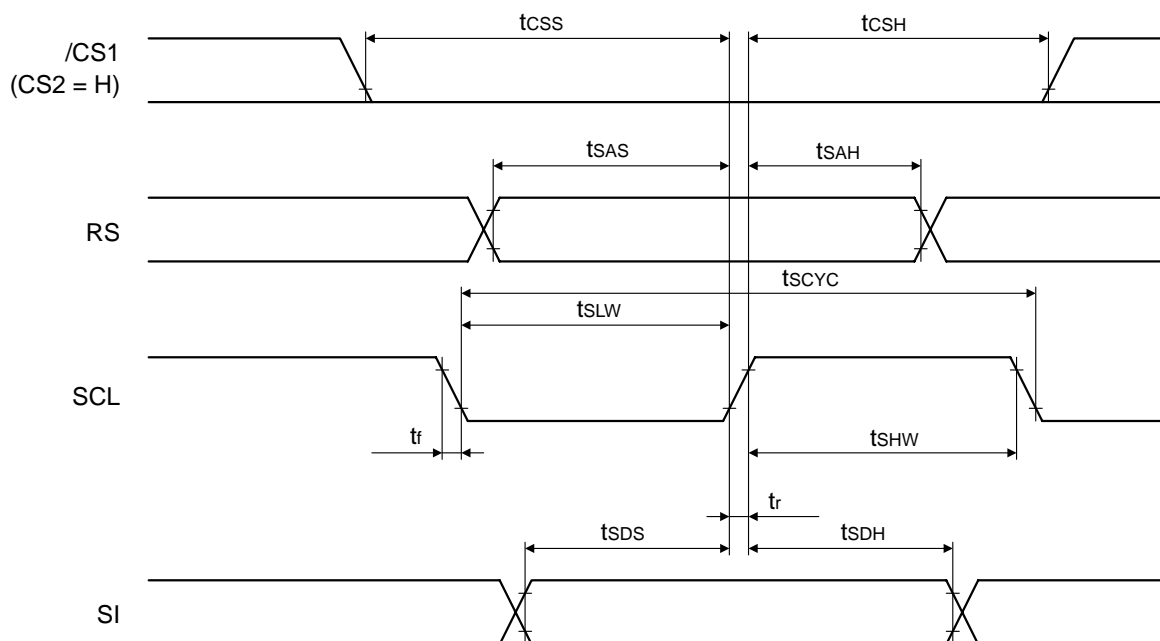

When $V_{DD1} = 1.7$ to 2.5 V

Parameter	Symbol	Conditions	MIN.	TYP. ^{Note}	MAX.	Unit
Serial clock cycle	t _{SCYC}	SCL	250			ns
SCL high-level pulse width	t _{SHW}	SCL	100			ns
SCL low-level pulse width	t _{SLW}	SCL	100			ns
Address hold time	t _{SAH}	RS	150			ns
Address setup time	t _{SAS}	RS	150			ns
Data setup time	t _{SDS}	SI	100			ns
Data hold time	t _{SDH}	SI	100			ns
CS - SCL time	t _{CSS}	CS	150			ns
	t _{CSH}	CS	150			ns

Note TYP. values are reference values when $T_A = 25^\circ\text{C}$.

When $V_{DD1} = 2.5$ to 3.6 V

Parameter	Symbol	Conditions	MIN.	TYP. ^{Note}	MAX.	Unit
Serial clock cycle	t _{SCYC}	SCL	150			ns
SCL high-level pulse width	t _{SHW}	SCL	60			ns
SCL low-level pulse width	t _{SLW}	SCL	60			ns
Address hold time	t _{SAH}	RS	90			ns
Address setup time	t _{SAS}	RS	90			ns
Data setup time	t _{SDS}	SI	60			ns
Data hold time	t _{SDH}	SI	60			ns
CS - SCL time	t _{CSS}	CS	90			ns
	t _{CSH}	CS	90			ns

Note TYP. values are reference values when $T_A = 25^\circ\text{C}$.

- Cautions**
1. The rise and fall times of input signal (t_r and t_f) are rated as 15 ns or less.
 2. All timing is rated based on 20% or 80% of V_{DD1} .

(4) Common

Parameter	Symbol	Conditions	MIN.	TYP. ^{Note}	MAX.	Unit
Clock input 1	f _N	When using OSC _{IN1} , external clock, and on-chip divider, 1/128 duty, B/W mode		36	150	kHz
		When using OSC _{IN1} , external clock, and on-chip divider, 1/128 duty, four-level gray scale mode		72	150	kHz
Clock input 2	f _P	When using OSC _{IN2} , external clock for partial display mode, but not using on-chip divider, B/W mode		10.6	50	kHz
		When using OSC _{IN2} , external clock for partial display mode, but not using on-chip divider, four-level gray scale mode		21.3	50	kHz

Note TYP. values are reference values when frame frequency = 70 Hz.

- Cautions 1.** The rise and fall times of input signal (t_r and t_f) are rated as 15 ns or less.
2. All timing is rated based on 20% or 80% of V_{DD1}.

Reset timing

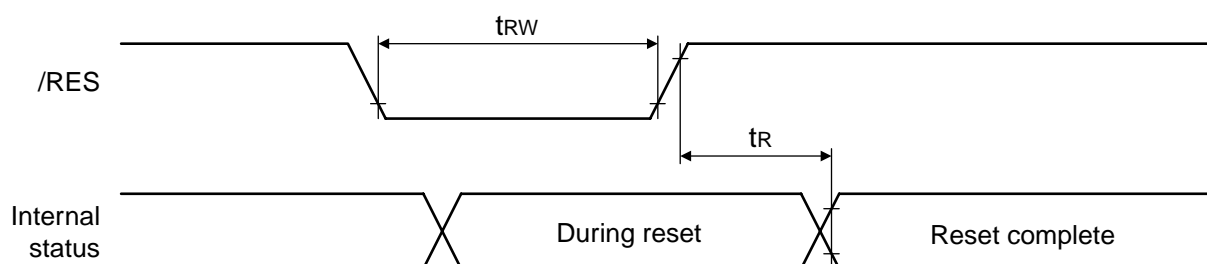

When V_{DD1} = 1.7 to 2.5 V

Parameter	Symbol	Conditions	MIN.	TYP. ^{Note}	MAX.	Unit
Reset time	t _R				50	μs
Reset low pulse width	t _{RW}	/RES	50			μs

Note TYP. values are reference values when T_A = 25°C.

When V_{DD1} = 2.5 to 3.6 V

Parameter	Symbol	Conditions	MIN.	TYP. ^{Note}	MAX.	Unit
Reset time	t _R				50	μs
Reset low pulse width	t _{RW}	/RES	50			μs

Note TYP. values are reference values when T_A = 25°C.

Caution All timing is rated based on 20% or 80% of V_{DD1}.

12. CPU INTERFACE (REFERENCE EXAMPLE)

The μPD16498 can be connected to either an i80 series CPU or an M68 series CPU. Also, if a serial interface connection is used, the number of signal lines can be reduced.

(1) M68 series CPU

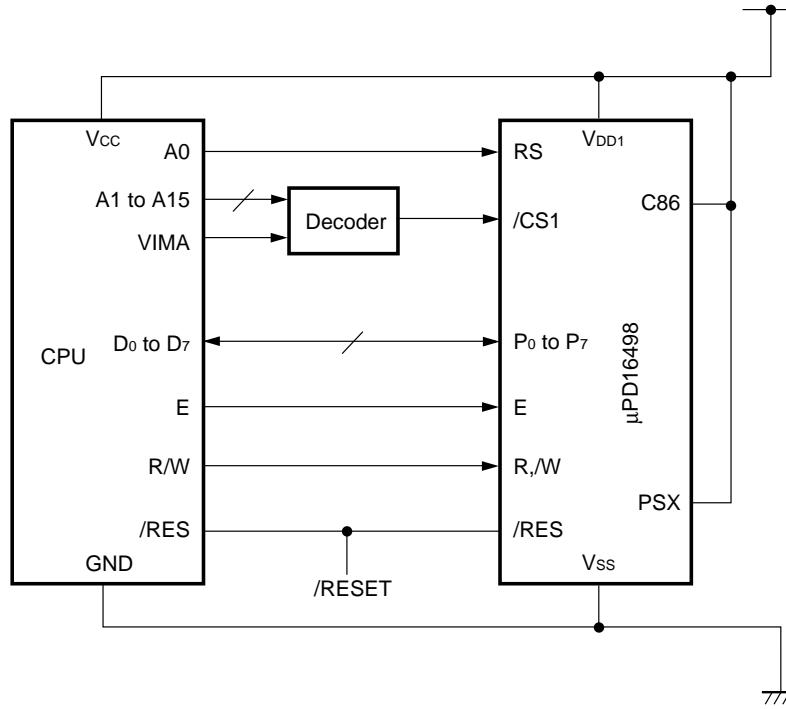

(2) i80 series CPU

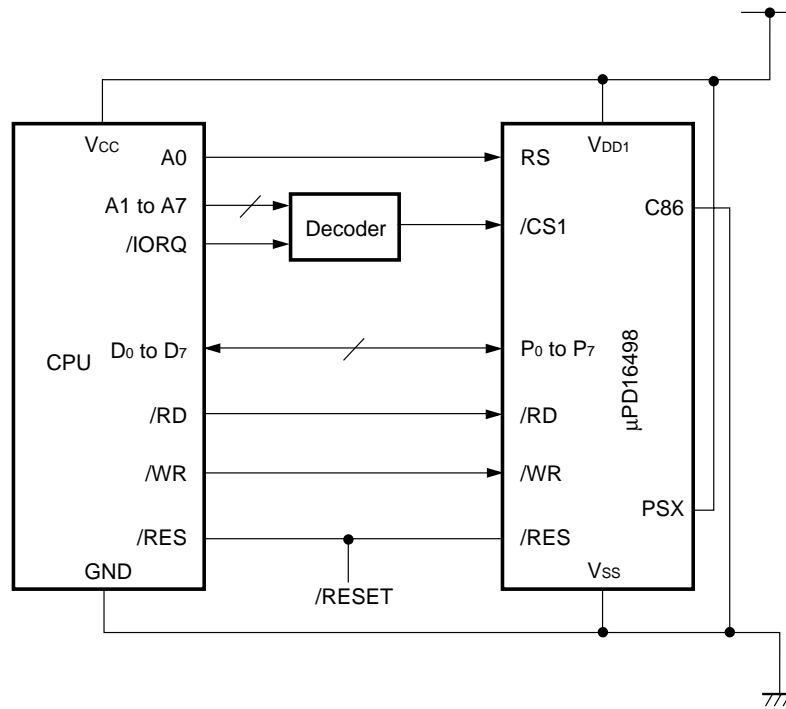

(3) When using serial interface

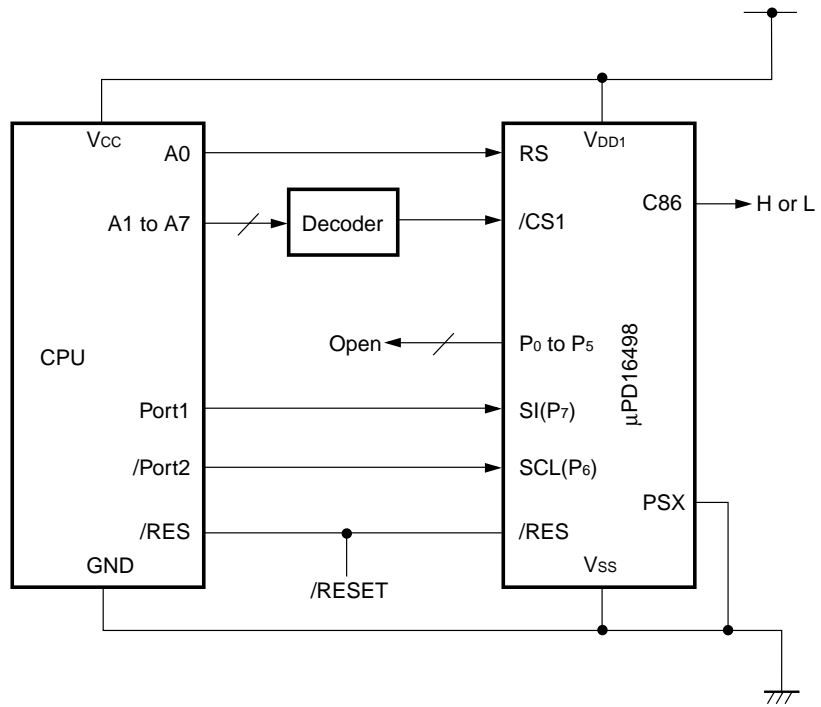

[MEMO]

[MEMO]

NOTES FOR CMOS DEVICES**① PRECAUTION AGAINST ESD FOR SEMICONDUCTORS**

Note:

Strong electric field, when exposed to a MOS device, can cause destruction of the gate oxide and ultimately degrade the device operation. Steps must be taken to stop generation of static electricity as much as possible, and quickly dissipate it once, when it has occurred. Environmental control must be adequate. When it is dry, humidifier should be used. It is recommended to avoid using insulators that easily build static electricity. Semiconductor devices must be stored and transported in an anti-static container, static shielding bag or conductive material. All test and measurement tools including work bench and floor should be grounded. The operator should be grounded using wrist strap. Semiconductor devices must not be touched with bare hands. Similar precautions need to be taken for PW boards with semiconductor devices on it.

② HANDLING OF UNUSED INPUT PINS FOR CMOS

Note:

No connection for CMOS device inputs can be cause of malfunction. If no connection is provided to the input pins, it is possible that an internal input level may be generated due to noise, etc., hence causing malfunction. CMOS devices behave differently than Bipolar or NMOS devices. Input levels of CMOS devices must be fixed high or low by using a pull-up or pull-down circuitry. Each unused pin should be connected to V_{DD} or GND with a resistor, if it is considered to have a possibility of being an output pin. All handling related to the unused pins must be judged device by device and related specifications governing the devices.

③ STATUS BEFORE INITIALIZATION OF MOS DEVICES

Note:

Power-on does not necessarily define initial status of MOS device. Production process of MOS does not define the initial operation status of the device. Immediately after the power source is turned ON, the devices with reset function have not yet been initialized. Hence, power-on does not guarantee out-pin levels, I/O settings or contents of registers. Device is not initialized until the reset signal is received. Reset operation must be executed immediately after power-on for devices having reset function.