

Description

The μPD7556/66A and μPD7566/66A are low-end versions of μPD7500 series products. These microcomputers incorporate a 4-bit comparator input and are useful as slave CPUs to high-end μPD7500 series or 8-bit μCOM-87 series products.

The μPD7556/56A/66/66A has output ports that can directly drive triacs and LEDs. Also, various mask-optional I/O circuits can be configured for a wide selection of outputs allowing a reduction of external circuitry in your design. There are two testable interrupts.

The μPD7556/56A and μPD7566/66A differ only in their clock circuitry. The μPD7556/56A uses an external resistor with an internal capacitor for an RC oscillator clock, where the μPD7566/66A uses a ceramic oscillator as a clock. These microcomputers are ideally suited to control devices such as air conditioners, microwave ovens, refrigerators, rice cookers, and audio equipment.

Features

- 45 instructions (subset of μPD7500 set B)
- Instruction cycle:
 - External clock: 2.86 μs/700 kHz, 5 V
 - RC oscillator (μPD7556/56A); 4 μs/500 kHz, 5 V
 - Ceramic resonator (μPD7566/66A): 2.86 μs/700 kHz, 5 V
- Program memory (ROM) of 1024 x 8-bits
- Data memory (RAM) of 64 x 4-bits
- 8-bit timer/event counter
- 4-bit comparator
- I/O lines: 20-μPD7556/56A; 19-μPD7566/66A
- Data memory retention at low supply voltage
- Standby (STOP/HALT) functions
- CMOS technology
- Low-power consumption
- Single power supply
 - 2.5 to 6.0 V (μPD7556/56A)
 - 2.7 to 6.0 V (μPD7566/66A)
 - 2.0 to 6.0 V (μPD7556A)

Ordering Information

Part Number	Package Type
μPD7556CS /	24-pin plastic shrink DIP
μPD7556ACS /	
μPD7566CS /	
μPD7566ACS /	
μPD7556G /	24-pin plastic SOP
μPD7556AG /	
μPD7566G /	
μPD7566AG /	

3

Pin Configurations

20-Pin Plastic Shrink DIP

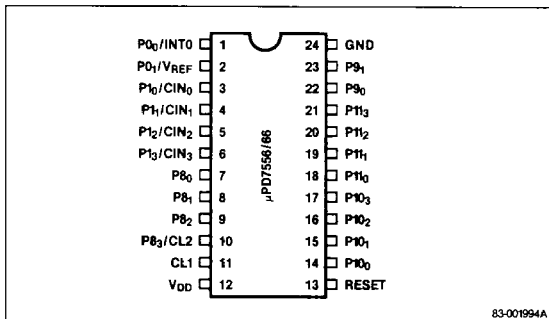

83-001994A

20-Pin Plastic SOP

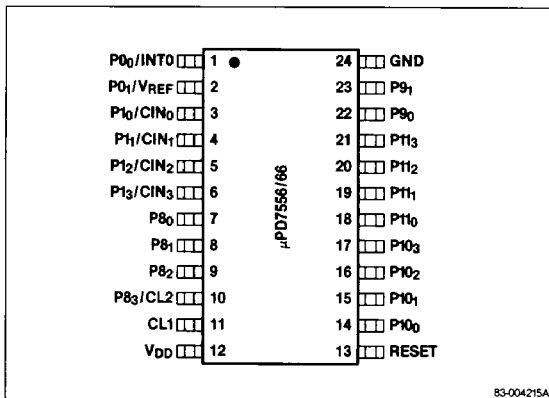

83-004215A

Pin Identification

Symbol	Function
P0 ₀ /INT0 P0 ₁ /V _{REF}	2-bit input port 0/testable input pin/ comparator reference voltage input pin
P1 ₀ /CIN ₀ P1 ₁ /CIN ₁ P1 ₂ /CIN ₂ P1 ₃ /CIN ₃	4-bit input port 1/4-bit comparator inputs
P8 ₀ -P8 ₂ P8 ₃ /CL2	3-bit output port 8 (μPD7566/66A) 3- (4-) bit output port 8/connection for RC oscillator (μPD7556/56A)/ceramic resonator (μPD7566/66A)
CL1	Connection for ceramic resonator or RC oscillator
V _{DD}	+5 V power supply
RESET	Reset input pin
P10 ₁ -P10 ₃	4-bit I/O port 10
P11 ₀ -P11 ₃	4-bit I/O port 11
P9 ₀ -P9 ₁	2-bit output port 9
V _{SS}	Ground

PIN FUNCTIONS

P0₀/INT0, P0₁/V_{REF} (Port 0/Count Clock input/Comparator reference voltage input)

Two-bit input port 0/count clock input/comparator reference voltage input. INT0 is an edge-sensitive testable input pin that detects a signal at the rising edge. V_{REF} is the comparator reference voltage input pin. A mask option specifies whether this pin is used as P0₁ or V_{REF}. If P0₀/INT0 is unused; connect it to ground. If P0₁/V_{REF} is unused, connect it to ground or V_{DD}. The port is in the input state at reset.

P1₀/CIN₀-P1₃/CIN₃ (Port 1/Comparator inputs)

Four-bit input port 1/comparator inputs. A mask option specifies whether these pins are used as digital input (Port 1) or as comparator inputs (CIN₀-CIN₃). If any of P1₀-P1₃ pins are unused, connect them to ground or V_{DD}. The port is the input state at reset.

P8₀-P8₂, P8₃-CL2 (Port 8/Clock input 2)

Four-bit output port 8. This port can sink 15 mA and interface 12 V⁽¹⁾. On the μPD7556/56A, the port function of P8₃/CL2 is specified by mask option. P8₃ is a normal output port on the μPD7566/66A. On the μPD7556/56A,

CL2 is one of the pins to which a resistor for RC oscillation is connected. On the μPD7566/66A, CL2 is one of the pins to which a ceramic resonator is connected. If any of P8₀-P8₂ pins are unused, leave them open. The port is in the high impedance state at reset.

CL1 (Clock input 1)

On the μPD7566/66A, CL1 is one of the two pins to which a resistor for RC oscillation is connected. On the μPD7566/66A, CL1 is one of the two pins to which a ceramic resonator is connected.

V_{DD} (Power supply)

Positive power supply.

RESET (Reset)

System reset input pin (active high). This pin can be internally connected to a pull-down resistor if specified by mask option.

P10₀-P10₃ (Port 10)

Four-bit I/O port. This port can sink 10 mA and interface 12 V⁽¹⁾. If any of these pins are unused, connect them to ground or V_{DD} in the input state, or leave open in the output state. The port is in the high impedance or high-level output state at reset.

P11₀-P11₃ (Port 11)

Four-bit I/O port. This port can sink 10 mA and interface 12 V⁽¹⁾. If any of these pins are unused, connect them to ground or V_{DD} in the input state, or leave open in the output state. The port is in the high impedance or high-level output state at reset.

P9₀-P9₁ (Port 9)

Two-bit output port. This port sinks 15 mA and can interface to 12 V⁽¹⁾. If either of these pins are unused, leave it open. The port is in the high impedance state at reset.

V_{SS} (Ground)

Ground.

Note: (1) 9 V for the μPD7556A/66A.

Pin Mask Options

Table 1 shows the mask options for all the port pins and the RESET pin. You may select these options in bit units.

Table 1. Pin Mask Options

Pin	Options
P0 ₀	1 No connection to internal resistor 2 Connected to internal pull-up resistor 3 Connected to internal pull-down resistor
P0 ₁ /V _{REF}	1 No connection to internal resistor 2 Connected to internal pull-up resistor 3 Connected to internal pull-down resistor 4 Used as V _{REF} pin 1 A bias of V _{DD} /2 internally applied to V _{REF} pin 2 Bias not applied
P1 ₀ /CIN ₀ - P1 ₃ /CIN ₃	1 No connection to internal resistor 2 Connected to internal pull-up resistor 3 Connected to internal pull-down resistor 4 Used as comparator input pins

Table 1. Pin Mask Options (cont)

Pin	Options
P8 ₀ -P8 ₂ / P9 ₀ -P9 ₁	1 CMOS (push-pull) output 2 N-channel, open-drain output
P8 ₃ /CL ₂ (1) option 1	1 Used as P8 ₃ 2 Used as CL ₂
P8 ₃ /CL ₂ (1) option 2	1 CMOS (push-pull) 2 N-channel open-drain
P10 ₀ -P10 ₃ P11 ₀ -P11 ₃	1 N-channel, open drain input/output 2 CMOS (push-pull) input/output 3 N-channel, open-drain input/output with internal pull-up resistor
RESET	1 Connected to internal pull-down resistor 2 Not connected to internal pull-down resistor

Notes:

(1) μPD7556/56A only.

μPD7556/56/66/66AA Block Diagram

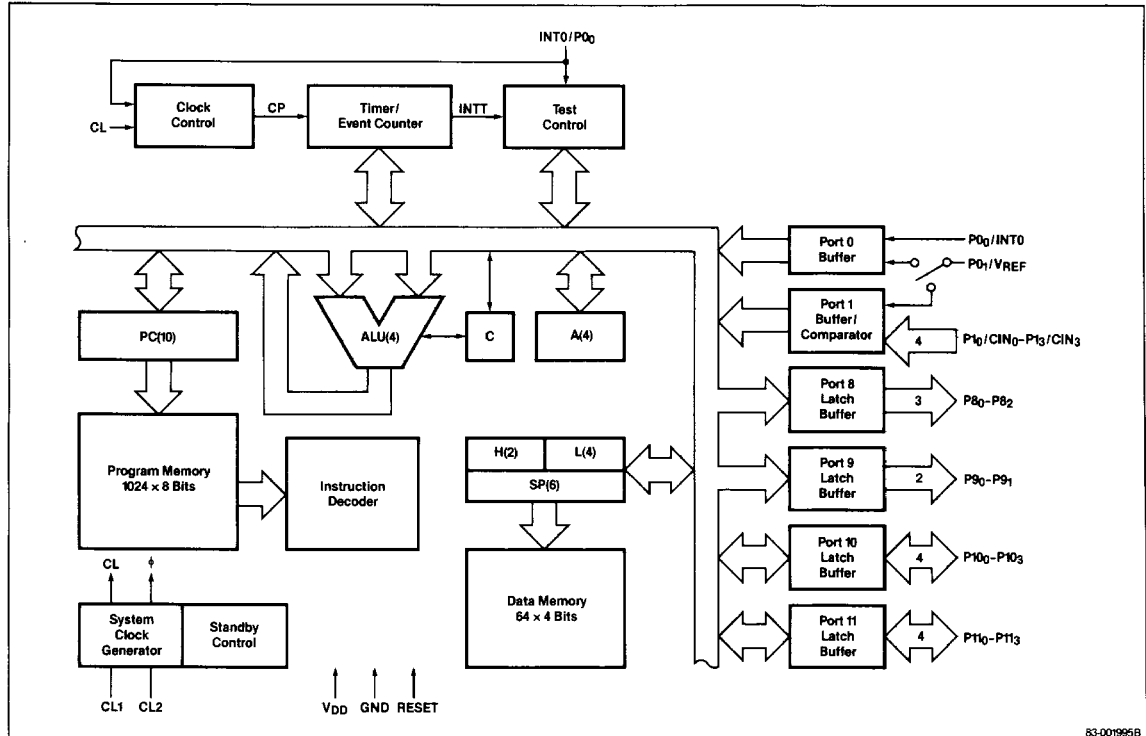

83-001995B

FUNCTIONAL DESCRIPTION

I/O Ports

Figure 1 shows the internal circuits at I/O ports P0, P8, P10, and P11.

Figure 1. I/O Ports

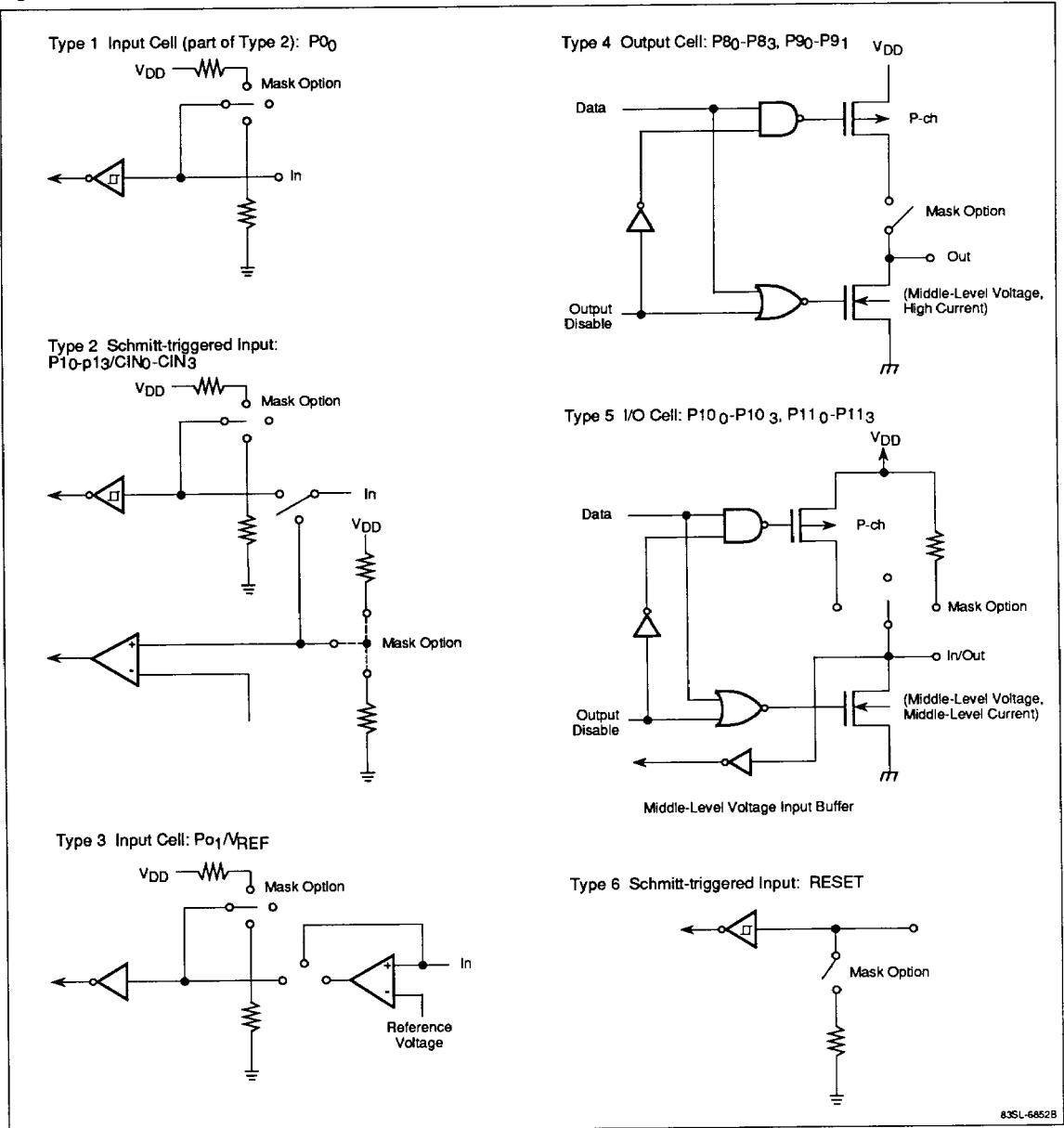

Program Memory

The μPD7556/56A/66/66A has a mask-programmable ROM with a capacity of 1024 words by 8 bits for program storage. It is addressed by the program counter. The reset start address is 000H. Figure 2 shows the program memory map.

General-Purpose Registers

Two registers, H(2-bit) and L(4-bit) are provided as general-purpose registers. Each register can be individually manipulated. The two registers also form pair register HL; H being the high register and L being the low one. The HL register is a data pointer to address data memory. Figure 3 shows the configuration of the general-purpose registers.

The L register also specifies an I/O port or mode register when an I/O instruction (IPL or OPL) is executed. It also specifies the bits of a port when the SPBL or RPBL instruction is executed.

Data Memory

The data memory is static RAM with a capacity of 64 words by 4 bits. Part of this memory is used as the stack area. The data memory is also used in 8-bit data processing when paired with the accumulator. Figure 4 shows the data memory map.

Data memory can be addressed directly, with the immediate data from an instruction; indirectly, with the contents of HL (including auto-increment and auto-decrement); and indirectly by the contents of the stack pointer.

You may use any area of the data memory as the stack. The boundary of the stack is determined by how the TAMSP instruction initializes the stack pointer. Once the boundary is set, a call or return instruction automatically accesses the stack.

When a call instruction is executed, the contents of the program counter and the program status word (PSW) are stored to the stack in the sequence shown in figure 5.

When a return instruction is executed, the contents of the program counter are automatically restored, but the PSW is not. The contents of data memory can be retained with a low supply voltage during STOP mode.

Accumulator

The accumulator is a 4-bit register used in arithmetic operations. The accumulator can process 8-bit data with paired data addressed by HL. Figure 6 shows the configuration of the accumulator.

Arithmetic Logic Unit

The arithmetic logic unit (ALU) is a 4-bit arithmetic circuit that performs operations such as binary addition, logical operation, increment, decrement, comparison, and bit processing.

Program Status Word

The program status word (PSW) consists of two skip flags (SK0 and SK1), a carry flag (C), and bit 1, which is always zero. Figure 7 shows the configuration of the PSW.

The contents of the PSW are stored to the stack when a call instruction is executed, but are not restored from the stack by the return instruction.

The skip flags retain the following skip conditions: string effect by LAI or LHLL instruction, and skip condition satisfied by an instruction other than a string-effect instruction. The skip flag is set or reset according to the instruction executed.

The carry flag is set to 1 if an addition instruction (ACSC) generates a carry from bit 3 of the ALU. If no carry is generated, the flag is reset to zero. The SC instruction sets the carry flag and the RC instruction resets it.

When a RESET is input, the SK1 and SK0 flags are cleared to zero and the contents of the carry flag are undefined.

System Clock Generator

The system clock generator consists of a RC oscillator (μPD7556/56A), a ceramic resonator (μPD7566/66A), a 1/2 frequency divider, standby modes (STOP/HALT), and control circuit. Figure 8 is a circuit diagram of the system clock generator for the μPD7556/56A.

In the μPD7556/56A, the RC oscillator operates with a single external resistor connected across CL1 and CL2 (the capacitor C is incorporated). When the RC oscillator is not used, external clock pulses can be input by the CL1 pin. In this case, the RC oscillator functions as an inverting buffer. The output from the RC oscillator serves as the system clock (CL) which is then divided by two and used as the CPU clock (φ).

The standby mode control circuit is made up of a STOP flip-flop and a HALT flip-flop. The STOP instruction sets the STOP flip-flop and stops the system clock supply. This flip-flop also stops the RC oscillator. The STOP flip-flop is reset by the standby release signal that becomes active when one of the test requests flags is set or at the falling edge of the RESET signal. When the STOP flip-flop is reset, the RC oscillator resumes operation and supplies the system clock.

The HALT and STOP instructions and RESET HIGH set the HALT flip-flop which disables signals from going to the 1/2 frequency divider that generates the CPU clock. Only the CPU clock stops in HALT mode. The HALT flip-flop is reset by the same conditions as the STOP flip-flop.

Figure 9 shows the system clock generator circuit for the μPD7566/66A.

On the μPD7566/66A, the ceramic oscillator operates with a ceramic resonator connected across CL1 and CL2. The output from the ceramic oscillator is used as the system clock (CL); it is divided by two to produce the CPU clock (ϕ).

The standby mode control circuit is made up of a STOP flip-flop and a HALT flip-flop. The STOP instruction sets the STOP flip-flop and stops the ceramic oscillation, thus stopping the supply for all clocks. The STOP flip-flop is reset by the RESET signal (high level) and restarts ceramic oscillation. The supply of each clock resumes when RESET goes low.

The HALT instruction sets the HALT flip-flop which disables signals from going to the 1/2 frequency divider that generates the CPU clock. Only the CPU clock stops in HALT mode. The HALT flip-flop is reset by the HALT RELEASE signal (activated by setting at least one test request flag) or the falling edge of RESET, resuming supply of the CPU clock.

The HALT flip-flop is also set when RESET is active (high level). At power on reset operation, the rising edge of RESET starts ceramic oscillation; however, some time is required to achieve stable oscillation. To prevent the unstable clock from operating the CPU, the HALT flip-flop is set and the CPU clock is stopped while RESET is high. Accordingly, the high-level width of RESET must be more than the required stable time for the ceramic resonator.

Figure 2. Program Memory Map

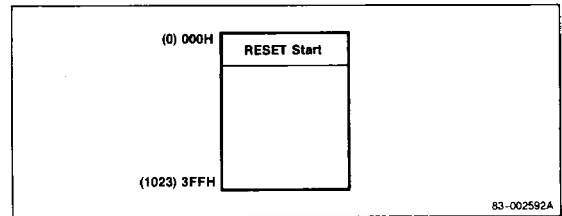

Figure 3. Configuration of General Purpose Registers

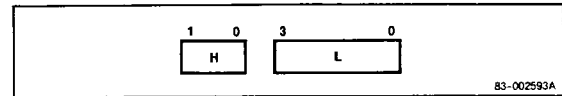

Figure 4. Data Memory Map

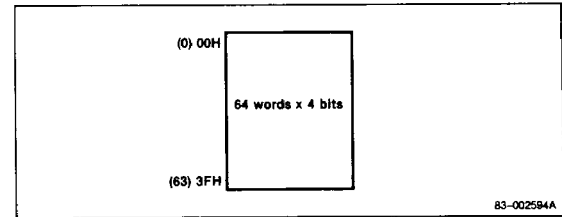

Figure 5. Call Instruction Storage to Stack

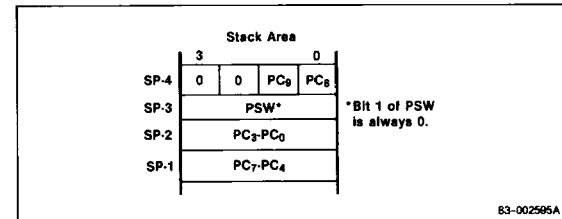

Figure 6. Configuration of the Accumulator

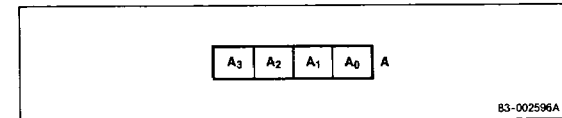

Figure 7. Configuration of the Program Status Word

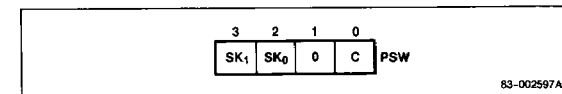

Figure 10. Clock Control Circuit

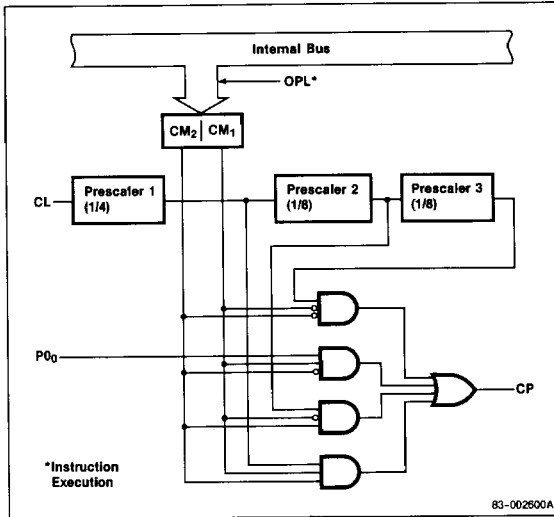

Table 2. Selecting the Count Pulse Frequency

CM2	CM1	Frequency Selected
0	0	CL/256
0	1	P0 ₀
1	0	CL/32
1	1	CL/4

Timer/Event Counter

The timer/event counter is a binary 8-bit up-counter which is incremented each time a count pulse is input. The TIMER instruction or a RESET signal clears it to 00H. When an overflow occurs, the counter is reset from FFH to 00H. Figure 11 shows the inputs and outputs of the counter.

Figure 11. Timer/Event Counter

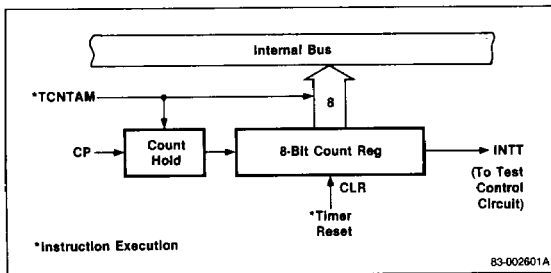

Test Control Circuit

The μPD7566/66A has two test sources, as shown in table 3.

The test control circuit consists of two test request flags (INTT RQF and INTO RQF) set by the two test sources, the SM₃ flag which determines whether INTO is enabled, and a test request flag control circuit that checks the contents of each test request flag by executing an SKI instruction and resetting the flags.

The OPL instruction (L = FH, corresponding to A₃) sets the SM₃ flag. INTO is enabled when SM₃ = 1.

Table 3. μPD7556/56A/66/66A Test Sources

Source	Function	Location	Request Flag
INTT	Overflow in timer/event counter	Internal	INTT RQF
INTO	Test request signal from P0 ₀ pin	External	INTO RQF

The request flag INTT RQF is set when a timer overflow occurs in the timer event counter. The SKI or TIMER instruction resets it.

The logical sum of the outputs from the test request flags releases HALT mode. The mode is released when one or both flags are set. Both flags and SM₃ are reset when the RESET signal is input. After reset, signal input to the INTO pin is inhibited as the initial condition.

Figure 12 is a block diagram of the test control circuit.

Figure 12. Test Control Circuit Block Diagram

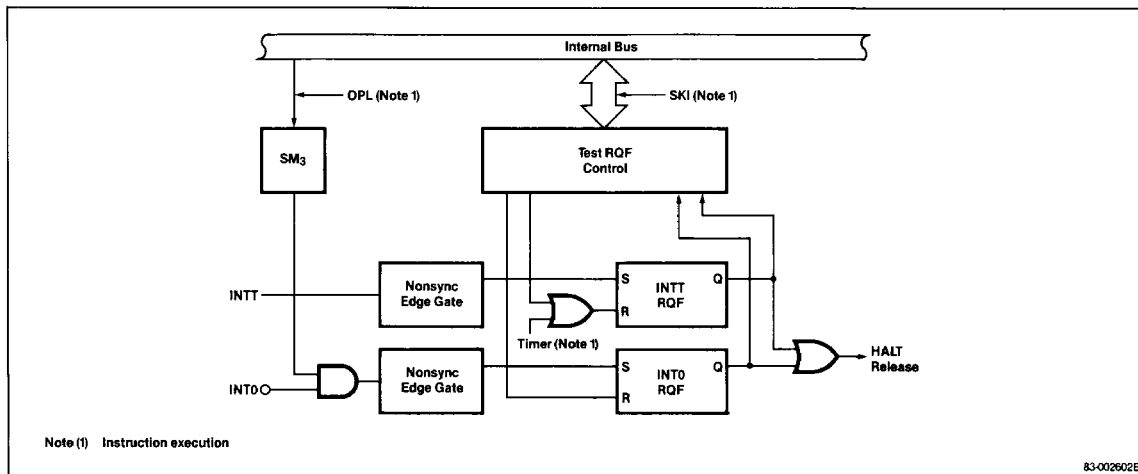

3

Standby Modes

The μPD7556/56A/66/66A has two standby modes to reduce power consumption while the program is in the wait state. The STOP and HALT instructions set these modes.

When the program enters a standby mode, program execution stops and the contents of all registers and data memory immediately before the program entered standby mode are retained. The timer can operate even in HALT mode.

The RESET signal or STANDBY release signal⁽¹⁾ releases STOP mode. HALT mode is released when one or both of the test request flags are set, or when the RESET signal is input. The program cannot enter a standby mode when a test request is being set, even if the STOP or HALT command is executed.

If there is some uncertainty about the state of the test request flags, execute the SKI instruction to reset them so the program can enter standby mode.

Table 4 compares STOP and HALT modes. The main difference is that STOP mode stops the system clock and HALT does not. Oscillation stops during STOP mode. The power consumed by the oscillator is the difference between the two modes. In STOP mode, data memory can be retained with a lower supply voltage.

Note: (1) Standby release signal for μPD7556/56A only.

Table 4. STOP and HALT Modes

Mode	CL	φ	P0 ₀	CPU	Timer	Released by
STOP	x	x	o	x	Δ	RESET input INTT RQF, INTO RQF (μPD7556/56A only)
HALT	o	x	o	x	o	INTT RQF INTO RQF RESET input

Notes:

- (1) o: operates. x: stops.
- Δ: operates depending on clock source, μPD7556/56A; if external clock is used, STOP instruction will not stop CL. In this case STOP mode acts as HALT mode.

Power-on Reset Circuit

Figure 13 shows a circuit example of the power-on reset circuit using a resistor and a capacitor. This is the simplest reset control circuit. Figure 14 shows the circuit with a pull-down resistor internally connected to RESET as a mask option.

μPD7556/56A/66/66A Applications

Figures 15-18 show examples of application circuits for the μPD7556/56A/66/66A.

Table 5 compares the features of the low-end products of the 7500 series devices.

Figure 13. Power-on Reset Circuit

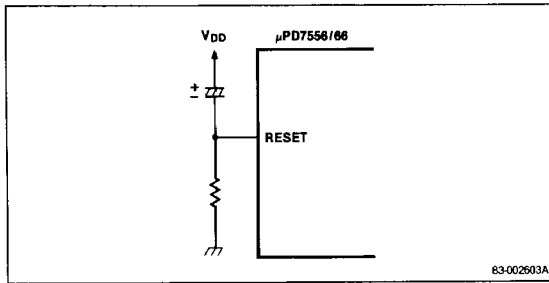

Figure 14. Power-on Reset Circuit with Pull-down Resistor

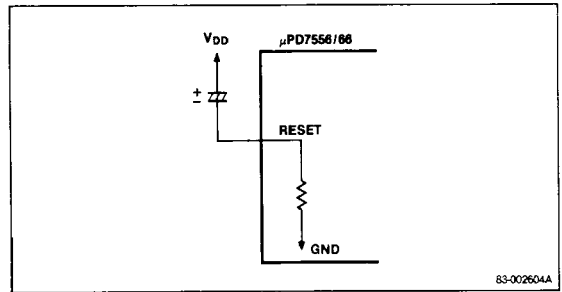

Table 5. Product Comparison

Item		μPD7554/54A	μPD7564/64A	μPD7556/56A	μPD7566/66A
Instruction cycle/system clock (5 V)	RC	4 μs/ 500 kHz		4 μs/ 500 kHz	
	External	2.86 μs/ 700 kHz		2.86 μs/ 700 kHz	
	Ceramic		3 μs/ 660 kHz		3 μs/ 660 kHz
Instruction set		47	47	45	45
ROM		1024 x 8	1024 x 8	1024 x 8	1024 x 8
RAM		64 x 4	64 x 4	64 x 4	64 x 4
I/O port total		16 (max)	15	20 (max)	19
Port 0		P0 ₀ -P0 ₃	P0 ₀ -P0 ₃	P0 ₀ -P0 ₁	P0 ₀ -P0 ₁
Port 1				P1 ₀ -P1 ₃	P0 ₁ -P0 ₃
Port 8		P8 ₀ -P8 ₂ P8 ₂ /CL2	P8 ₀ -P8 ₂	P8 ₀ -P8 ₂ P8 ₃ /CL2	P8 ₀ -P8 ₂
Port 9				P9 ₀ -P9 ₁	P9 ₀ -P9 ₁
Port 10		P10 ₀ -P10 ₃	P10 ₀ -P10 ₃	P10 ₀ -P10 ₃	P10 ₀ -P10 ₃
Port 11		P11 ₀ -P11 ₃	P11 ₀ -P11 ₃	P11 ₀ -P11 ₃	P11 ₀ -P11 ₃
Timer/Event counter		8-bit	8-bit	8-bit	8-bit
Serial interface		8-bit	8-bit		
Comparator				4-channel	4-channel
Process		CMOS	CMOS	CMOS	CMOS
Package		20-pin plastic SOP	20-pin plastic SOP	24-pin plastic SOP	24-pin plastic SOP
		20-pin shrink DIP	20-pin shrink DIP	24-pin shrink DIP	24-pin shrink DIP

Figure 15. Refrigerator or Air Conditioner Circuitry

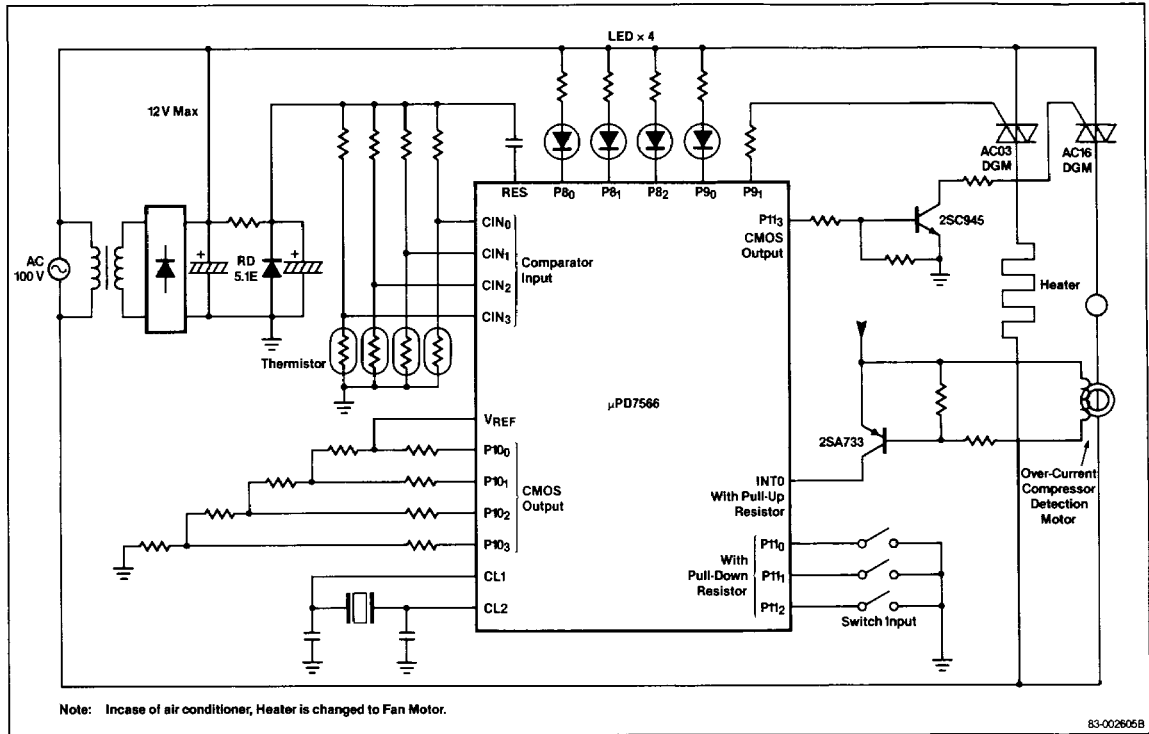

Figure 16. Rice Cooker Circuitry

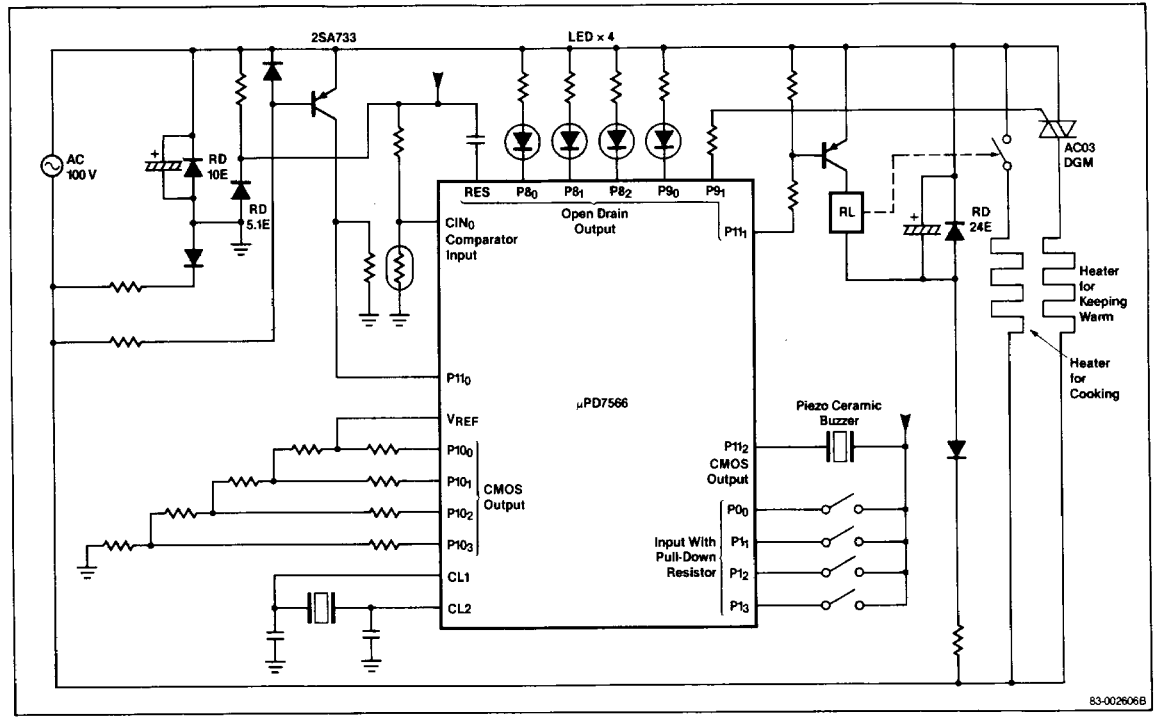

Figure 17. Washing Machine Circuitry

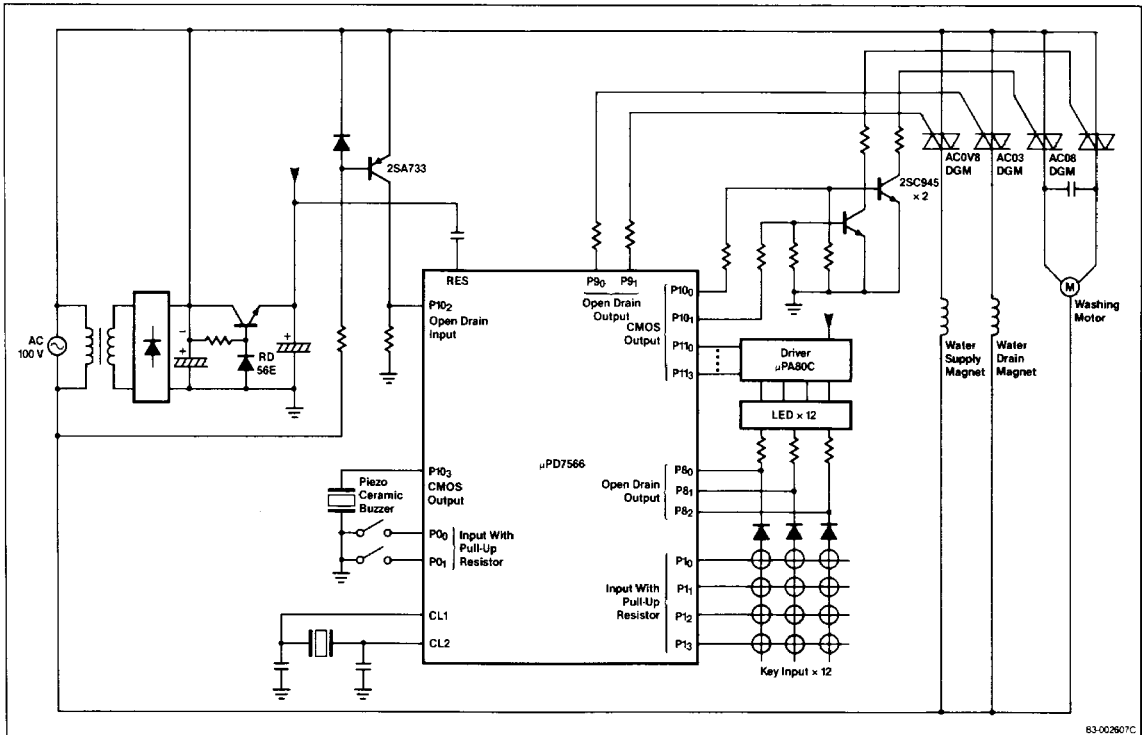
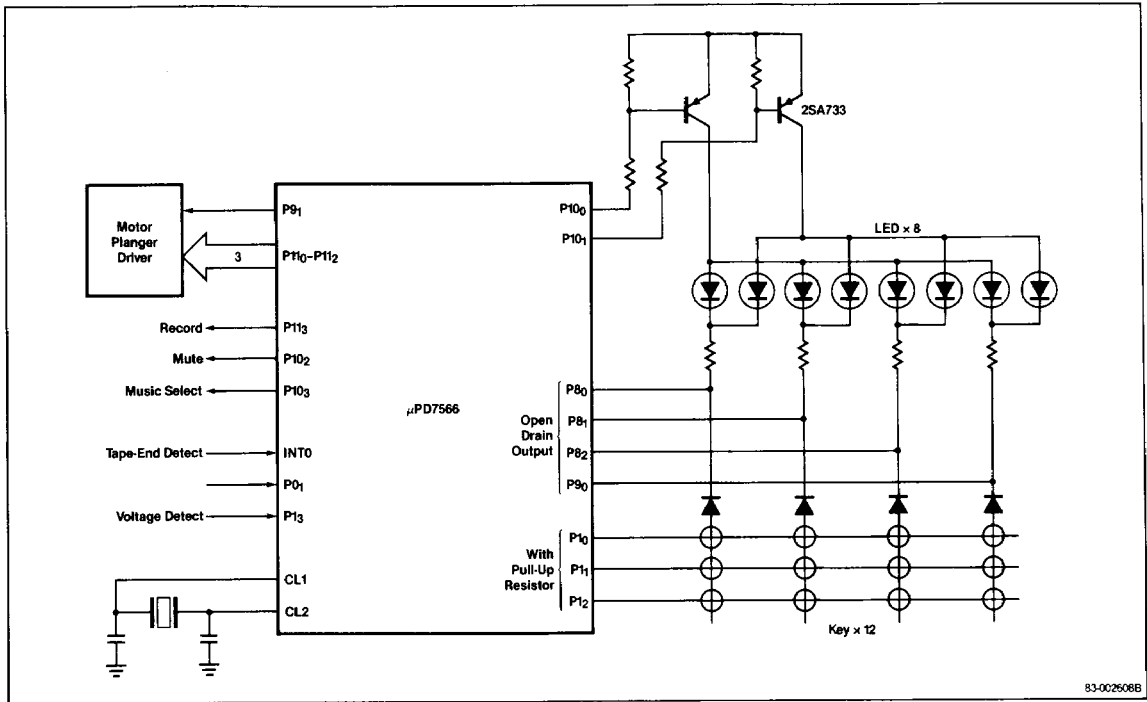

Figure 18. Tape Deck Controller Circuitry



ELECTRICAL SPECIFICATIONS

Absolute Maximum Ratings

$T_A = 25^\circ\text{C}$

Operating temperature, T_{OPT}	-10 to $+70^\circ\text{C}$
Storage temperature, T_{STG}	-65 to $+150^\circ\text{C}$
Power supply voltage, V_{DD}	-0.3 to $+7.0\text{ V}$
Input voltage, V_i	
Except ports 10, 11	-0.3 to $V_{DD} + 0.3\text{ V}$
Ports 10, 11 (Note 1)	-0.3 to $V_{DD} + 0.3\text{ V}$
(Note 2)	-0.3 to $+13\text{ V}$
μPD7556A/66A (Note 2)	-0.3 to $+11\text{ V}$
Output voltage, V_O	
Except ports 8, 10, 11	-0.3 to $V_{DD} + 0.3\text{ V}$
Ports 8, 10, 11 (Note 1)	-0.3 to $V_{DD} + 0.3\text{ V}$
(Note 2)	-0.3 to $+13\text{ V}$
μPD7556A/66A (Note 2)	-0.3 V to $+11\text{ V}$
Output current, high I_{OH}	
One port	-5 mA
All output ports, total	-15 mA
Output current, low I_{OL}	
P_{01} , P_{02}	5 mA
Ports 10, 11	15 mA
Ports 8, 9	30 mA
All ports, total	100 mA
Power dissipation, P_D ($T_A = +70^\circ\text{C}$)	
Shrink DIP	480 mW
SOP	250 mW

Exposure to Absolute Maximum Ratings for extended periods may affect device reliability; exceeding the ratings could cause permanent damage. The device should be operated within the limits specified under DC and AC Characteristics.

Notes:

- (1) CMOS I/O or N-channel open drain + internal pull-up resistor.
- (2) N-channel open drain I/O.

Capacitance

$T_A = 25^\circ\text{C}$, $V_{DD} = V_{SS} = 0\text{ V}$; $f = 1\text{ MHz}$;

Unmeasured pins returned to V_{SS}

Parameter	Symbol	Min	Typ	Max	Unit	Conditions
Input capacitance	C_i			15	pF	P_{00} - P_{04} ; P_{10} - P_{13} ; C_{IN0} - C_{IN3} ;
Output capacitance	C_O			35	pF	Port 8
I/O capacitance	$C_{I/O}$			35	pF	Ports 8-11

DC Characteristics 1; V_{DD} = 2.5 to 3.3 V; μPD7556/56A

T_A = -10 to +70°C; GND = 0 V

Parameter	Symbol	Min	Typ	Max	Unit	Conditions
Input high voltage except CL1	V _{IH1}	0.8 V _{DD}		V _{DD}	V	
Input high voltage CL1	V _{IH2}	V _{DD} - 0.3		V _{DD}	V	
Input high voltage ports 10, 11	V _{IH3}	0.8 V _{DD}		12 (Note 1); 9 (Note 2)	V	
Input high voltage RESET	V _{IHDR}	0.9 V _{DDDR}		V _{DDDR} + 0.2	V	Data retention mode
Input low voltage except CL1	V _{IL1}	0		0.2 V _{DD}	V	
Input low voltage CL1	V _{IL2}	0		0.3	V	
Input leakage current except CL1	I _{LI1}	-3		3	μA	0 V ≤ V _I ≤ V _{DD}
Input leakage current CL1	I _{LI2}	-10		10	μA	0 V ≤ V _I ≤ V _{DD}
Input leakage current ports 10, 11	I _{LI3}			10 (Note 1) 10 (Note 2)	μA	V _I = 12 V V _I = 9 V
Output voltage high ports 8-11	V _{OH}	V _{DD} - 1.0			V	I _{OH} = -80 μA
Output voltage low ports 10, 11	V _{OL}			0.5	V	I _{OL} = 350 μA
Output voltage low ports 8-9	V _{OL}			0.5	V	I _{OL} = 500 μA
Output leakage current	I _{LO1}	-3		3	μA	0 V ≤ V _O ≤ V _{DD}
Output leakage current ports 8-11	I _{LO2}			10 (Notes 1, 2)	μA	V _O = 12 V μPD7556; V _O = 9 V μPD7556A
Supply voltage, data retention mode	V _{DDDR}	2.0		6.0	V	
Supply current, normal operation; R oscillation (Note 3)	I _{DD1}		55 40	180 150	μA	V _{DD} = 3 V ±0.3 V; R = 150 kΩ ±2% V _{DD} = 2.5 V; R = 150 kΩ ±2%
Supply current, HALT mode; R oscillation (Note 3)	I _{DD2}		25 18	80 60	μA	V _{DD} = 3 V ±0.3 V; R = 150 kΩ ±2% V _{DD} = 2.5 V; R = 150 kΩ ±2%
Supply current, STOP mode (Note 3)	I _{DD3}		0.1	5	μA	
Supply current, data retention mode (Note 3)	I _{DDDR}		0.1	5	μA	V _{DDDR} = 2.0 V
Pull-up/down resistance, ports 0-1, RESET	RP1	23.5	47	70.5	kΩ	
Pull-up resistance, ports 10, 11	RP2	7.5	15	22.5	kΩ	

Notes:

- (1) N-channel, open drain I/O ports, μPD7556.
- (2) N-channel, open drain I/O ports, μPD7556A.
- (3) Current in built-in pull-up/down resistors excluded.

DC Characteristics 2; $V_{DD} = 2.7$ to 6.0 V; μPD7556/56A/66/66A

$T_A = -10$ to $+70^\circ\text{C}$; $GND = 0$ V

Parameter	Symbol	Min	Typ	Max	Unit	Conditions
Input high voltage except CL1	V_{IH1}	$0.7 V_{DD}$		V_{DD}	V	
Input high voltage CL1 (Note 2)	V_{IH2}	$V_{DD} - 0.5$		V_{DD}	V	
Input high voltage ports 10, 11	V_{IH3}	$0.7 V_{DD}$		12 (Note 1); 9 (Note 2)	V	
Input high voltage RESET	V_{IHDR}	$0.9 V_{DDDR}$		$V_{DDDR} + 0.2$	V	Data retention mode
Input low voltage except CL1 (Note 3)	V_{IL1}	0		$0.3 V_{DD}$	V	
Input low voltage CL1	V_{IL2}	0		0.5	V	
Input leakage current except CL1 (Note 3)	I_{LI1}	-3		3	μA	$0\text{ V} \leq V_I \leq V_{DD}$
Input leakage current CL1	I_{LI2}	-10		10	μA	$0\text{ V} \leq V_I \leq V_{DD}$
Input leakage current ports 10, 11 (Note 4)	I_{LI3}			10	μA	$V_I = 9\text{ V}$ μPD7556A/66A; or 12 V
Output voltage high P0 ₁ , P0 ₂ , ports 8-11	V_{OH}	$V_{DD} - 2.0$			V	$V_{DD} = 4.5$ to 6.0 V; $I_{OH} = -1$ mA
	V_{OH}	$V_{DD} - 1.0$			V	$V_{DD} = 2.7$ V; $I_{OH} = -100$ μA
Output voltage low ports 10, 11	V_{OL}			0.4	V	$V_{DD} = 4.5$ to 6.0 V; $I_{OL} = 1.6$ mA
				2.0	V	$V_{DD} = 4.5$ to 6.0 V; $I_{OL} = 10$ mA
				0.5	V	$V_{DD} = 2.7$ V; $I_{OL} = 400$ μA
Output voltage low ports 8-9	V_{OL}			2.0	V	$V_{DD} = 4.5$ to 6.0 V; $I_{OL} = 15$ mA
				0.5	V	$V_{DD} = 2.7$ V; $I_{OL} = 600$ μA
Output leakage current	I_{LO1}	-3		3	μA	$0\text{ V} \leq V_O \leq V_{DD}$
Output leakage current, port 8-11 (Note 4)	I_{LO2}			10	μA	$V_O = 12\text{ V}$ μPD7556/66, $V_O = 9\text{ V}$ μPD7556A/66A
Supply voltage, data retention mode	V_{DDDR}	2.0		6.0	V	
Supply current, normal operation; ceramic oscillation (Notes 3, 5)	I_{DD1}		650	2200	μA	$V_{DD} = 5\text{ V} \pm 0.5\text{ V}$; $f_{CC} = 700\text{ kHz}$
			120	360	μA	$V_{DD} = 3\text{ V} \pm 10\%$; $f_{CC} = 300\text{ kHz}$
Supply current, normal operation; R oscillation (Note 3)	I_{DD1}		270	900	μA	$V_{DD} = 5\text{ V} \pm 0.5\text{ V}$; $R = 56\text{ k}\Omega \pm 2\%$
			80	240	μA	$V_{DD} = 3\text{ V} \pm 10\%$; $R = 100\text{ k}\Omega \pm 2\%$
Supply current, HALT mode; ceramic oscillation (Note 3, 5)	I_{DD2}		450	1500	μA	$V_{DD} = 5\text{ V} \pm 0.5\text{ V}$; $f_{CC} = 700\text{ kHz}$
			65	200	μA	$V_{DD} = 3.0\text{ V} \pm 10\%$; $f_{CC} = 300\text{ kHz}$
Supply current, HALT mode; R oscillation (Note 3)	I_{DD2}		120	400	μA	$V_{DD} = 5\text{ V} \pm 0.5\text{ V}$; $R = 56\text{ k}\Omega \pm 2\%$
			35	110	μA	$V_{DD} = 3\text{ V} \pm 10\%$; $R = 100\text{ k}\Omega \pm 2\%$
Supply current, STOP mode (Note 3)	I_{DD3}		0.1	10	μA	$V_{DD} = 5\text{ V} \pm 0.5\text{ V}$
			0.1	5	μA	$V_{DD} = 3\text{ V} \pm 10\%$
Supply current, data retention mode (Note 3)	I_{DDDR}		0.1	5	μA	$V_{DDDR} = 2.0\text{ V}$
Pull-up/down resistance, port 0, RESET	RP1	23.5	47	70.5	kΩ	
Pull-up resistance, ports 8-11	RP2	7.5	15	22.5	kΩ	

Notes:

- (1) μPD7556/66.
- (2) μPD7556A/66A.
- (3) Current in built-in pull-up/down resistors excluded.
- (4) N-channel, open-drain I/O ports.
- (5) μPD7566/66A.

3

DC Characteristics 3; V_{DD} = 2.0 to 3.3 V; μPD7556A only

T_A = -10 to +70°C; GND = 0 V

Parameter	Symbol	Min	Typ	Max	Unit	Conditions
Input high voltage except CL1	V _{IH1}	0.8 V _{DD}		V _{DD}	V	
Input high voltage CL1	V _{IH2}	V _{DD} - 0.2		V _{DD}	V	
Input high voltage ports 10, 11	V _{IH3}	0.85 V _{DD}		9	V	
Input high voltage RESET	V _{IHDR}	0.9 V _{DDDR}		V _{DDDR} + 0.2	V	Data retention mode
Input low voltage except CL1	V _{IL1}	0		0.15 V _{DD}	V	
Input low voltage CL1	V _{IL2}	0		0.2	V	
Input leakage current except CL1	I _{LI1}	-3		3	μA	0 V ≤ V _I ≤ V _{DD}
Input leakage current CL1	I _{LI2}	-10		10	μA	0 V ≤ V _I ≤ V _{DD}
Input leakage current ports 10, 11 (Note 1)	I _{LI3}			10	μA	V _I = 9 V
Output voltage high P0 ₁ , P0 ₂ , ports 8-11	V _{OH}	V _{DD} - 1.0			V	I _{OH} = -70 μA
Output voltage low P0 ₁ , P0 ₂ , ports 10, 11	V _{OL}			0.5	V	Ports 10, 11: I _{OL} = 300 μA
Output voltage low ports 8, 9	V _{OL}			0.5	V	I _{OL} = 400 μA
Output leakage current (Note 2)	I _{LO1}	-3		3	μA	0 V ≤ V _O ≤ V _{DD}
Output leakage current ports 8-11 (Note 1)	I _{LO2}			10	μA	V _O = 9 V
Supply voltage, data retention mode	V _{DDDR}	2.0		6.0	V	
Supply current, normal operation; R oscillation (Note 2)	I _{DD1}		38	130	μA	V _{DD} = 3.0 ± 10%; R = 240 kΩ ± 2%
			20	70	μA	V _{DD} = 2.0 V; R = 240 kΩ ± 2%
Supply current, HALT mode; R oscillation (Note 2)	I _{DD2}		17	60	μA	V _{DD} = 3 V ± 10%; R = 240 kΩ ± 2%
			8	25	μA	V _{DD} = 2 V; R = 240 kΩ ± 2%
Supply current, STOP mode (Note 2)	I _{DD3}		0.1	5	μA	
Supply current, data retention mode (Note 2)	I _{DDDR}		0.1	5	μA	V _{DDDR} = 2.0 V
Pull-up/down resistance, port 0, RESET	RP1	23.5	47	70.5	kΩ	
Pull-up resistance, ports 8-11	RP2	7.5	15	22.5	kΩ	

Notes:

- (1) N-channel, open-drain I/O ports.
- (2) Current in built-in pull-up/down resistors excluded.

Comparator

$T_A = -10$ to $+70^\circ\text{C}$; $V_{DD} = 3.0$ to 6.0 V, $GND = 0$ V

Parameter	Symbol	μPD7556/56A			μPD7566/66A			Unit	Conditions
		Min	Typ	Max	Min	Typ	Max		
Input voltage range	V_{CIN}/V_{REF}	0		V_{DD}	0		V_{DD}	V	All comparators
Response time	T_{COMP}	2		4	2		4	MC(Note 1)	All comparators
Input voltage resolution	ΔV_{CIN}			100			100	mV	All comparators
			10	50		10	50	mV	All comparators; $V_{DD} = 5\text{ V} \pm 0.5\text{ V}$
Input leakage current	I_{CIN}/I_{REF}	-3		3	-3		3	μA	All comparators
V_{REF} bias resistance (R1, R2)	BIAS		100			100		kΩ	(R1 = R2) typically
Comparator circuit current (Note 2)	I_{DDCMP}		50			50		μA	Comparator; $V_{DD} = 5\text{ V} \pm 0.5\text{ V}$

Notes:

- (1) Machine cycle.
- (2) Excluding current through bias resistor.

AC Characteristics 1; $V_{DD} = 2.5$ to 3.3 V; μPD7556/56A

$T_A = -10$ to $+70^\circ\text{C}$; $GND = 0$ V

Parameter	Symbol	Min	Typ	Max	Unit	Conditions
System clock oscillation frequency, CL1, CL2	f_{CC}	140	180	220	kHz	$R = 150\text{ k}\Omega \pm 2\%$
		140	175	210		$V_{DD} = 2.5\text{ V}; R = 150\text{ k}\Omega \pm 2\%$
External clock frequency, CL1	f_C	10		250	kHz	50% duty
System clock rise time, CL1	t_{CR}			200	ns	
System clock fall time, CL1	t_{CF}			200	ns	
System clock pulse width, high	t_{CH}	2		50	μs	
System clock pulse width, low	t_{CL}	2		50	μs	
External clock frequency ($P0_0$)	f_{P00}	0		250	kHz	50% duty
$P0_0$ rise time	t_{CRP0}			200	ns	
$P0_0$ fall time	t_{CFP0}			200	ns	
$P0_0$ pulse width, high	t_{P00H}	2			μs	
$P0_0$ pulse width, low	t_{P00L}	2			μs	
INT0 high time	t_{OH}	30			μs	
INT0 low time	t_{OL}	30			μs	
RESET high time	t_{RSH}	30			μs	
RESET low time	t_{RSL}	30			μs	
RESET setup time	t_{SRS}	0			μs	
RESET hold time	t_{HRS}	0			μs	

AC Characteristics 2; V_{DD} = 2.7 to 6.0 V; μPD7556/56A/66/66A

T_A = -10 to +70°C; GND = 0 V

Parameter	Symbol	Min	Typ	Max	Unit	Conditions
System clock oscillation frequency (Note 1)	f _{CC}	400	500	600	kHz	V _{DD} = 4.5 to 6.0 V; R = 56 kΩ ±2%
		200	250	300		
External clock frequency, CL1	f _C	10		710	kHz	V _{DD} = 4.5 to 6.0 V; 50% duty
		10		350		
System clock oscillation frequency (Note 2)	f _{CC}	290	700	710	kHz	V _{DD} = 4.5 to 6.0V
		290	500	510		
		290	400	410		
		290	300	310		
Oscillator setup (Note 2)	t _{OS}	20			ms	OS stabilization time after minimum of operating voltage reached
System clock rise time, CL1	t _{CR}			200	ns	
System clock fall time, CL1	t _{CF}			200	ns	
System clock pulse width	t _{CH}	0.7		50	μs	
System clock pulse width, CL1	t _{CL}	1.45		50	μs	V _{DD} = 2.7 V
External clock frequency (P0 ₀)	f _{P00}	0		710	kHz	V _{DD} = 4.5 to 6.0 V; 50% duty
		0		350		
P0 ₀ rise time	t _{CRP0}			200	ns	
P0 ₀ fall time	t _{CFP0}			200	ns	
P0 ₀ pulse width, high	t _{P00H}	0.7			μs	V _{DD} = 4.5 to 6.0 V
P0 ₀ pulse width, low	t _{P00L}	1.45			μs	V _{DD} = 2.7 V
INT0 high time	t _{OH}	10			μs	
INT0 low time	t _{OL}	10			μs	
RESET high time	t _{RSH}	10			μs	
RESET low time	t _{RSL}	10			μs	
RESET setup time	t _{SRS}	0			μs	
RESET hold time	t _{HRS}	0			μs	

Notes:

(1) μPD7556/56A.

(2) μPD7566/66A.

AC Characteristics 3; $V_{DD} = 2.0$ to 3.3 V; μPD7556A only

$T_A = -10$ to $+70^\circ\text{C}$; GND = 0 V

Parameter	Symbol	Min	Typ	Max	Unit	Conditions
System clock oscillation frequency	f_{CC}	65	120	145	kHz	$R = 240\text{ k}\Omega \pm 2\%$
System clock oscillation frequency, CL1, CL2	f_{CC}	65	100	130	kHz	$V_{DD} = 2.0\text{ V}$; $R = 240\text{ k}\Omega \pm 2\%$
External clock frequency, CL1	f_C	10		150	kHz	50% duty
System clock rise time, CL1	t_{CR}			200	ns	
System clock fall time, CL1	t_{CF}			200	ns	
System clock pulse width, high	t_{CH}	3.3		50	μs	
System clock pulse width, low	t_{CL}	3.3		50	μs	
External clock frequency (PO_0)	f_{P00}	0		150	kHz	50% duty
PO_0 rise time	t_{CRP0}			200	ns	
PO_0 fall time	t_{CFP0}			200	ns	
PO_0 pulse width, high	t_{P00H}	3.3			μs	
PO_0 pulse width, low	t_{P00L}	3.3			μs	
INT0 high time	t_{OH}	50			μs	
INT0 low time	t_{OL}	50			μs	
RESET high time	t_{RSH}	50			μs	
RESET low time	t_{RSL}	50			μs	
RESET setup time	t_{SRS}	0			μs	
RESET hold time	t_{HRS}	0			μs	

Timing Waveforms

Clocks

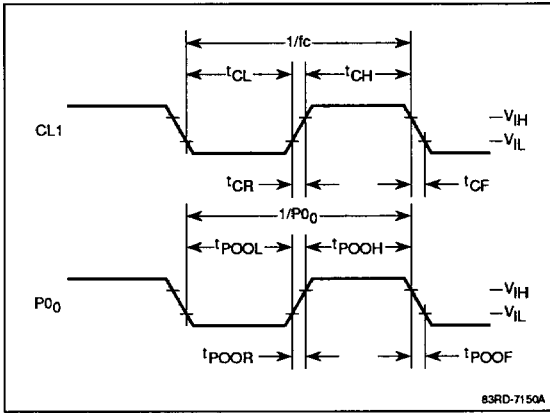

External Interrupt

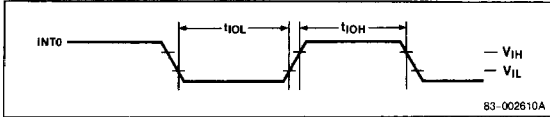

Reset

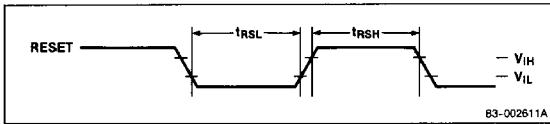

Data Retention Mode, μPD7556/56A

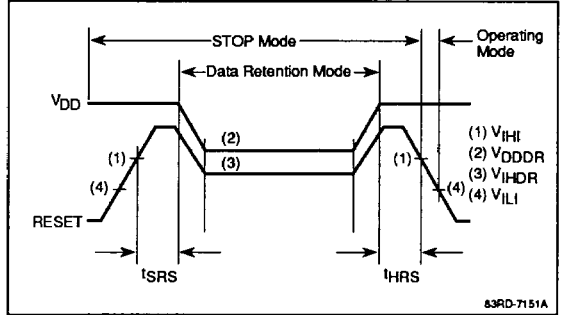

Data Retention Mode, μPD7566/66A

