

7400 PIXELS CCD LINEAR IMAGE SENSOR

The μ PD8670A is a high sensitive and high-speed CCD (Charge Coupled Device) linear image sensor which changes optical images to electrical signal.

The μ PD8670A is a 2-output type CCD sensor with 2 rows of high-speed charge transfer register, which transfers the photo signal electrons of 7400 pixels separately in odd and even pixels. And it has reset feed-through level clamp circuits and voltage amplifiers. Therefore, it is suitable for 600 dpi/A3 high-speed digital copiers, multi-function products and so on.

FEATURES

- Valid photocell : 7400 pixels
- Photocell pitch : 4.7 μ m
- Photocell size : 4.7 \times 4.7 μ m²
- Resolution : 24 dot/mm (600 dpi) A3 (297 \times 420 mm) size (shorter side)
- Data rate : 44 MHz MAX. (22 MHz/1 output)
- Output type : 2 outputs in-phase operation, and out of phase also supported
- High sensitivity : 17.0 V/lx \cdot s TYP. (Light source: Daylight color fluorescent lamp)
- Peak response wavelength : 550 nm (green)
- Low image lag : 1 % MAX.
- Drive clock level : CMOS output under +5 V operation
- Power supply : +12 V
- On-chip circuits : Reset feed-through level clamp circuits
Voltage amplifiers

ORDERING INFORMATION

Part Number	Package
μ PD8670ACY	CCD linear image sensor 32-pin plastic DIP (10.16 mm (400))

The information in this document is subject to change without notice. Before using this document, please confirm that this is the latest version.
Not all products and/or types are available in every country. Please check with an NEC Electronics sales representative for availability and additional information.

DIFFERENCE BETWEEN μPD8670ACY AND μPD3747D

Part	Item	μPD8670ACY	μPD3747D	Referential Page
Features	Output type	2 outputs out of phase or in phase	2 outputs in phase only	1
	Sensitivity (Daylight color fluorescent lamp)	TYP. 17 V/lx•s	TYP. 19 V/lx•s	
Ordering information	Package	32-pin plastic DIP	22-pin ceramic DIP (CERDIP)	
Pin configuration	Input clock	φCP1, φCP2 separated, φR1, φR2 separated, φ2L1, φ2L2 separated (Output: in/out of phase)	φCP common, φR common, φ2L common (Output: in phase)	4
Block diagram				3
Application circuit example				21
Absolute maximum ratings	Equivalent circuit Tr.	2SA1206, 2SC1842	2SA1005, 2SC945	
	Operating ambient temperature	0 to +60°C	-25 to +55°C	5
Storage temperature	-40 to +70°C	-40 to +100°C		
Recommended operating condition	Each clock amplitude	Addition of specifications (from 4.5 V to 5.8 V)	-	
Electrical characteristics	ADS, DSNU, DR1, DR2	Change of specifications	-	6
	R _F	TYP. 17 V/lx•s	TYP. 19 V/lx•s	
	RFTN	Addition of PRFTN, RFTN1, RFTN2	Only RFTN	
	t _a	TYP. 13 ns Addition of min. max.	TYP. 14 ns	
	σ _{bit} , σ _{line} , σ _{shot}	Addition of condition (t6)	-	
Input pin capacitance	Capacitance	Change of specification Addition of note	-	7
Timing chart	Operation	Addition of out-of-phase timing chart	-	8, 9
	t6	MIN. 5 ns	MIN. 0 ns	12, 14
	t10	MIN. 0 ns	MIN. t3	
	t13, t16, t17	MAX. 10000 ns	-	14
Close point	-	Change of specifications	-	15
Definitions	V _{os} , RFTN	Additional item	-	19
Recommended soldering condition	Partial heating method	350°C or blow, 3 seconds or less	300°C or blow, 3 seconds or less	24
Package drawing	Package	32-pin plastic DIP	22-pin ceramic DIP (CERDIP)	23
	Cap	Plastic cap 0.7t	Glass cap 0.7t	
	From CCD to bottom of package	2.45 ± 0.3 mm	2.38 ± 0.3 mm	
	From CCD to top of cap	(2.0) mm	(1.95) mm	

Remark T_A = +25°C, V_{OD} = 12 V

BLOCK DIAGRAM

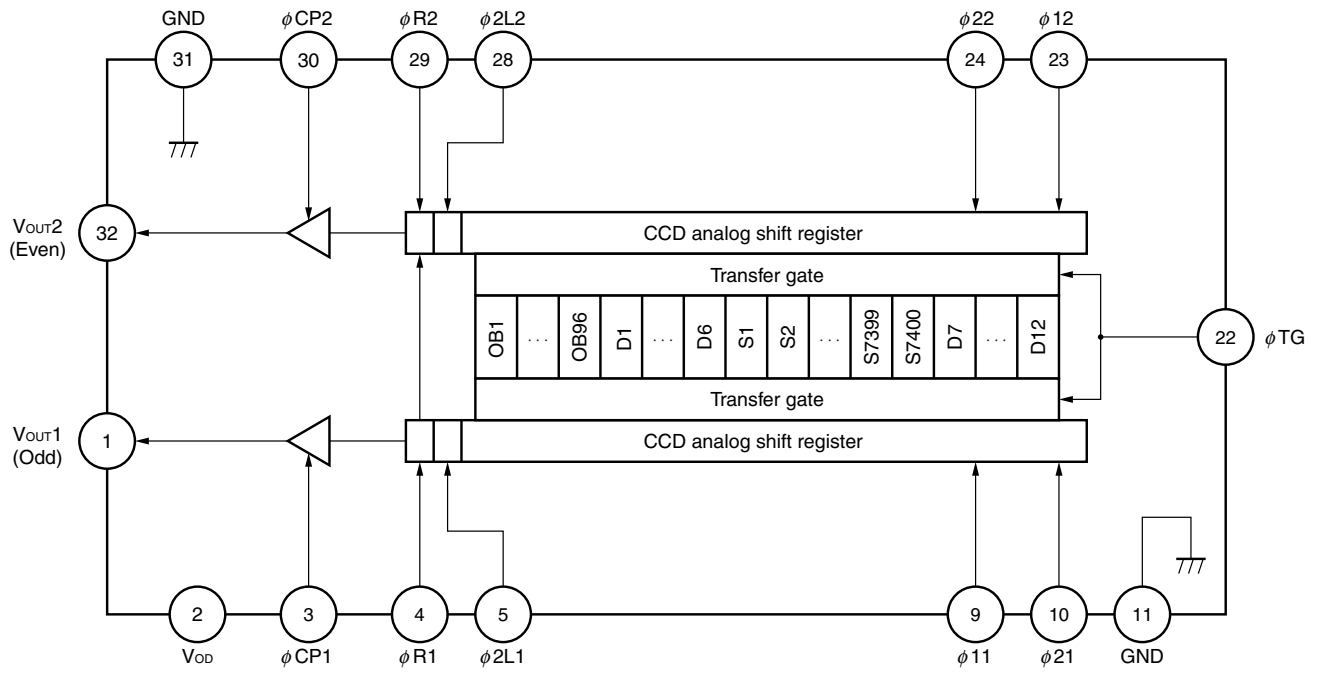

PIN CONFIGURATION (Top View)

CCD linear image sensor 32-pin plastic DIP (10.16 mm (400))

• μPD8670ACY

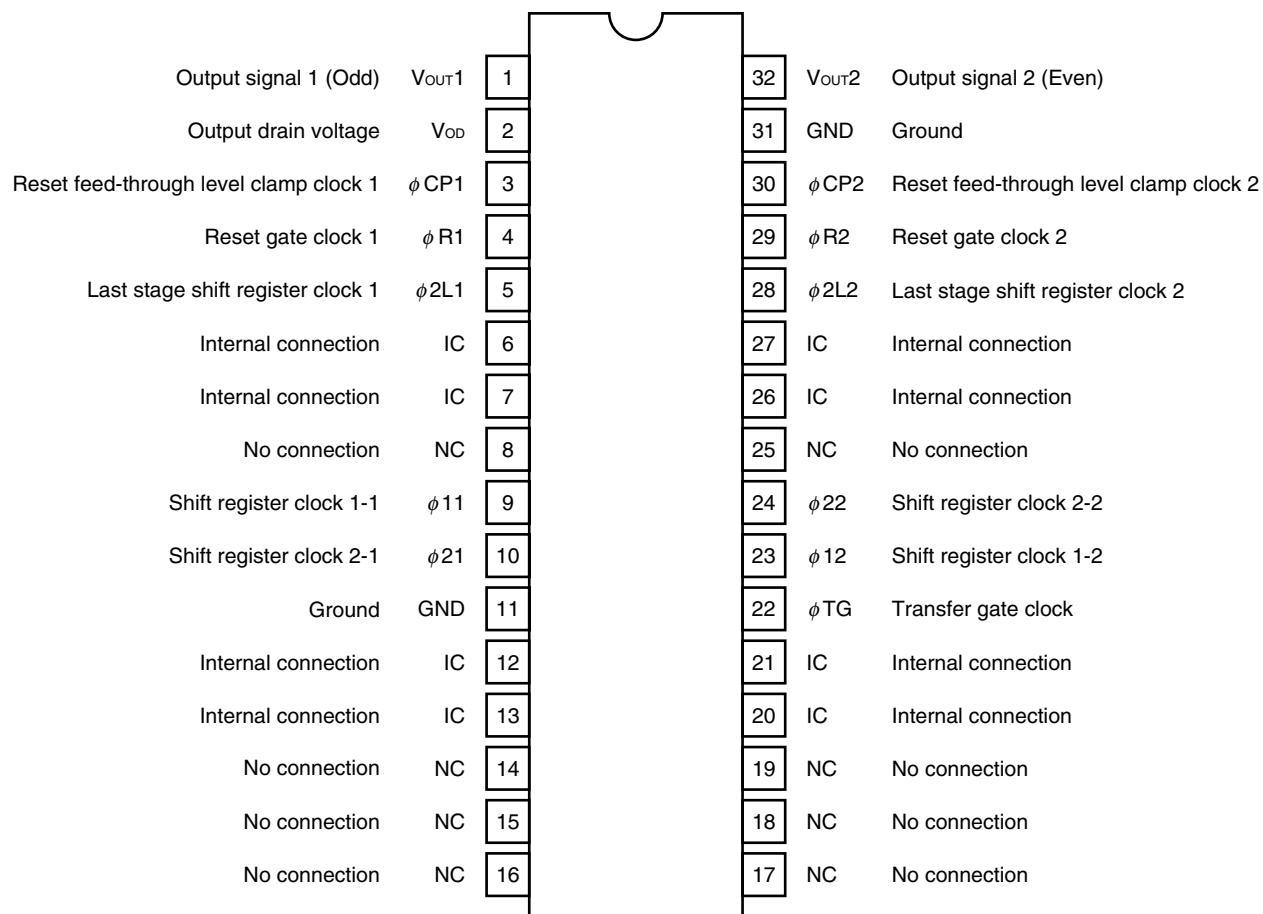

- Cautions**
1. Leave pins 6, 7, 12, 13, 20, 21, 26 and 27 (IC) unconnected.
 2. Connect the No connection pins (NC) to GND.

PHOTOCELL STRUCTURE DIAGRAM

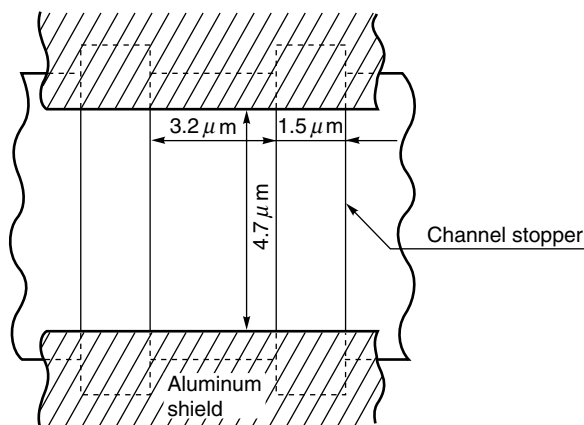

ABSOLUTE MAXIMUM RATINGS (T_A = +25°C)

Parameter	Symbol	Ratings	Unit
Output drain voltage	V _{OD}	-0.3 to +14.0	V
Shift register clock voltage	V _{φ1} , V _{φ2}	-0.3 to +8.0	V
Last stage shift register clock voltage	V _{φ2L}	-0.3 to +8.0	V
Reset gate clock voltage	V _{φR}	-0.3 to +8.0	V
Transfer gate clock voltage	V _{φTG}	-0.3 to +8.0	V
Reset feed-through level clamp clock voltage	V _{φCP}	-0.3 to +8.0	V
Operating ambient temperature ^{Note}	T _A	0 to +60	°C
Storage temperature	T _{stg}	-40 to +70	°C

Note Use at the condition without dew condensation.

Caution Product quality may suffer if the absolute maximum rating is exceeded even momentarily for any parameter. That is, the absolute maximum ratings are rated values at which the product is on the verge of suffering physical damage, and therefore the product must be used under conditions that ensure that the absolute maximum ratings are not exceeded.

RECOMMENDED OPERATING CONDITIONS (T_A = +25°C)

Parameter	Symbol	Conditions	MIN.	TYP.	MAX.	Unit
Output drain voltage	V _{OD}		11.4	12.0	12.6	V
Shift register clock high level	V _{φ1H} , V _{φ2H}		4.5	5.0	5.5	V
Shift register clock low level	V _{φ1L} , V _{φ2L}		-0.3	0	+0.5	V
Last stage shift register clock high level	V _{φ2LH}		4.5	5.0	5.5	V
Last stage shift register clock low level	V _{φ2LL}		-0.3	0	+0.5	V
Reset gate clock high level	V _{φRH}		4.5	5.0	5.5	V
Reset gate clock low level	V _{φRL}		-0.3	0	+0.5	V
Reset feed-through level clamp clock high level	V _{φCPH}		4.5	5.0	5.5	V
Reset feed-through level clamp clock low level	V _{φCPL}		-0.3	0	+0.5	V
Transfer gate clock high level	V _{φTGH}		4.5	5.0	5.5	V
Transfer gate clock low level	V _{φTGL}		-0.3	0	+0.5	V
Shift register clock amplitude	V _{φ1_pp} , V _{φ2_pp}	f < 10 MHz/ch	4.0	5.0	5.8	V
		f ≥ 10 MHz/ch	4.5	5.0	5.8	V
Last stage shift register clock amplitude	V _{φ2L_pp}		4.5	5.0	5.8	V
Reset gate clock amplitude	V _{φR_pp}		4.5	5.0	5.8	V
Reset feed-through level clamp clock amplitude	V _{φCP_pp}		4.5	5.0	5.8	V
Transfer gate clock amplitude	V _{φTG_pp}		4.5	5.0	5.8	V
Data rate	2f _{φR}		1	2	44	MHz

ELECTRICAL CHARACTERISTICS

$T_A = +25^\circ\text{C}$, $V_{OD} = 12\text{ V}$, $f_{\phi R} = 1\text{ MHz}$, data rate = 2 MHz, storage time = 10 ms, input signal clock = 5 V_{p-p},
light source : 3200 K halogen lamp + C-500S (infrared cut filter, t = 1 mm) + HA-50 (heat absorbing filter, t = 3 mm)

Parameter	Symbol	Test Conditions	MIN.	TYP.	MAX.	Unit	
Saturation voltage	V _{sat}		1.5	2.0	–	V	
Saturation exposure	SE	Daylight color fluorescent lamp	–	0.10	–	lx•s	
Photo response non-uniformity	PRNU	V _{OUT} = 500 mV	–	5.0	10.0	%	
Average dark signal	ADS	Light shielding	–	1.0	6.0	mV	
Dark signal non-uniformity	DSNU	Light shielding	–	16.0	28.0	mV	
Power consumption	P _w		–	350	420	mW	
Output impedance	Z _o		–	0.2	0.3	kΩ	
Response	R _F	Daylight color fluorescent lamp	13.6	17.0	20.4	V/lx•s	
Image lag	IL	V _{OUT} = 500 mV	–	0.5	1.0	%	
Offset level ^{Note 1}	V _{OS}		3.7	4.7	5.7	V	
Output fall delay time ^{Note 2}	t _d	V _{OUT} = 500 mV	11.0	13.0	15.0	ns	
Total transfer efficiency	TTE	V _{OUT} = 1 V, data rate = 44 MHz	94	98	–	%	
Register imbalance	RI	V _{OUT} = 500 mV	0	1.0	4.0	%	
Response peak			–	550	–	nm	
Dynamic range	DR1	V _{sat} /DSNU	–	125	–	times	
	DR2	V _{sat} /σ bit, t ₆ ≥ 20 ns	–	1000	–	times	
Reset feed-through noise ^{Note 1}	PRFTN	Light shielding, t ₄ = 5 ns	–	+0.4	–	V	
	RFTN1		–1.0	–0.4	+0.2	V	
	RFTN2		–0.3	+0.2	+0.7	V	
Random noise	σ bit	Light shielding, bit clamp mode	t ₆ = 5 ns	–	2.6	–	mV
			t ₆ ≥ 20 ns	–	2.0	–	mV
	σ line	Light shielding, line clamp mode	t ₆ ≥ 5 ns	–	8.0	–	mV
Shot noise	σ shot	V _{OUT} = 500 mV, bit clamp mode	t ₆ ≥ 5 ns	–	10.0	–	mV

Notes 1. Refer to 13 and 14 of **DEFINITION OF CHARACTERISTIC ITEMS**.

2. When the fall time of φ2L (t_{2'}) is the TYP. value (refer to **TIMING CHART 5, 6**). Note that V_{OUT1} and V_{OUT2} are the outputs of the two steps of emitter-follower shown in **APPLICATION CIRCUIT EXAMPLE**.

INPUT PIN CAPACITANCE ($T_A = +25^\circ\text{C}$, $V_{OD} = 12\text{ V}$)

Parameter	Symbol	Pin name	Pin No.	MIN.	TYP.	MAX.	Unit
Shift register clock pin capacitance 1	$C_{\phi 1}^{\text{Note}}$	$\phi 11$	9	225	250	275	pF
		$\phi 12$	23	200	220	240	pF
Shift register clock pin capacitance 2	$C_{\phi 2}^{\text{Note}}$	$\phi 21$	10	200	220	240	pF
		$\phi 22$	24	225	250	275	pF
Last stage shift register clock pin capacitance	$C_{\phi L}$	$\phi 2L1$	5	4	5	6	pF
		$\phi 2L2$	28	4	5	6	pF
Reset gate clock pin capacitance	$C_{\phi R}$	$\phi R1$	4	4	5	6	pF
		$\phi R2$	29	4	5	6	pF
Reset feed-through level clamp clock pin capacitance	$C_{\phi CP}$	$\phi CP1$	3	7	8	9	pF
		$\phi CP2$	30	7	8	9	pF
Transfer gate clock pin capacitance	$C_{\phi TG}$	ϕTG	22	240	270	300	pF

Note $C_{\phi 1}$, $C_{\phi 2}$ are equivalent capacitance with driving device, including the co-capacitance between $\phi 1$ and $\phi 2$.

Remark Pins 9 and 23 ($\phi 11$ and $\phi 12$), Pins 10 and 24 ($\phi 21$ and $\phi 22$) aren't each connected inside of the device.

TIMING CHART 1 (Bit clamp mode, Out of phase operation)

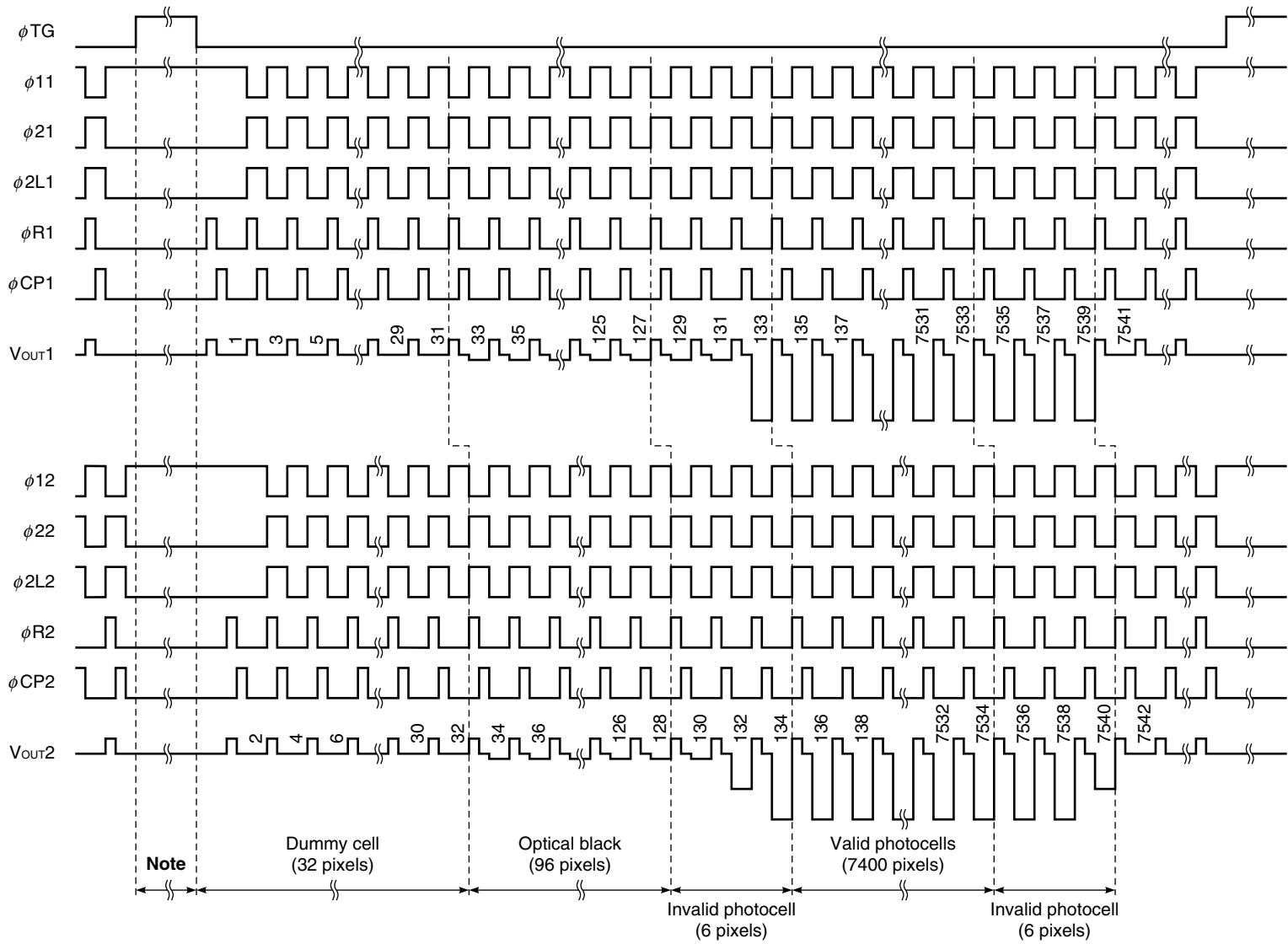

Note Set the ϕ_{R1} , ϕ_{R2} , ϕ_{CP1} and ϕ_{CP2} to low level during this period.

TIMING CHART 2 (Line clamp mode, Out of phase operation)

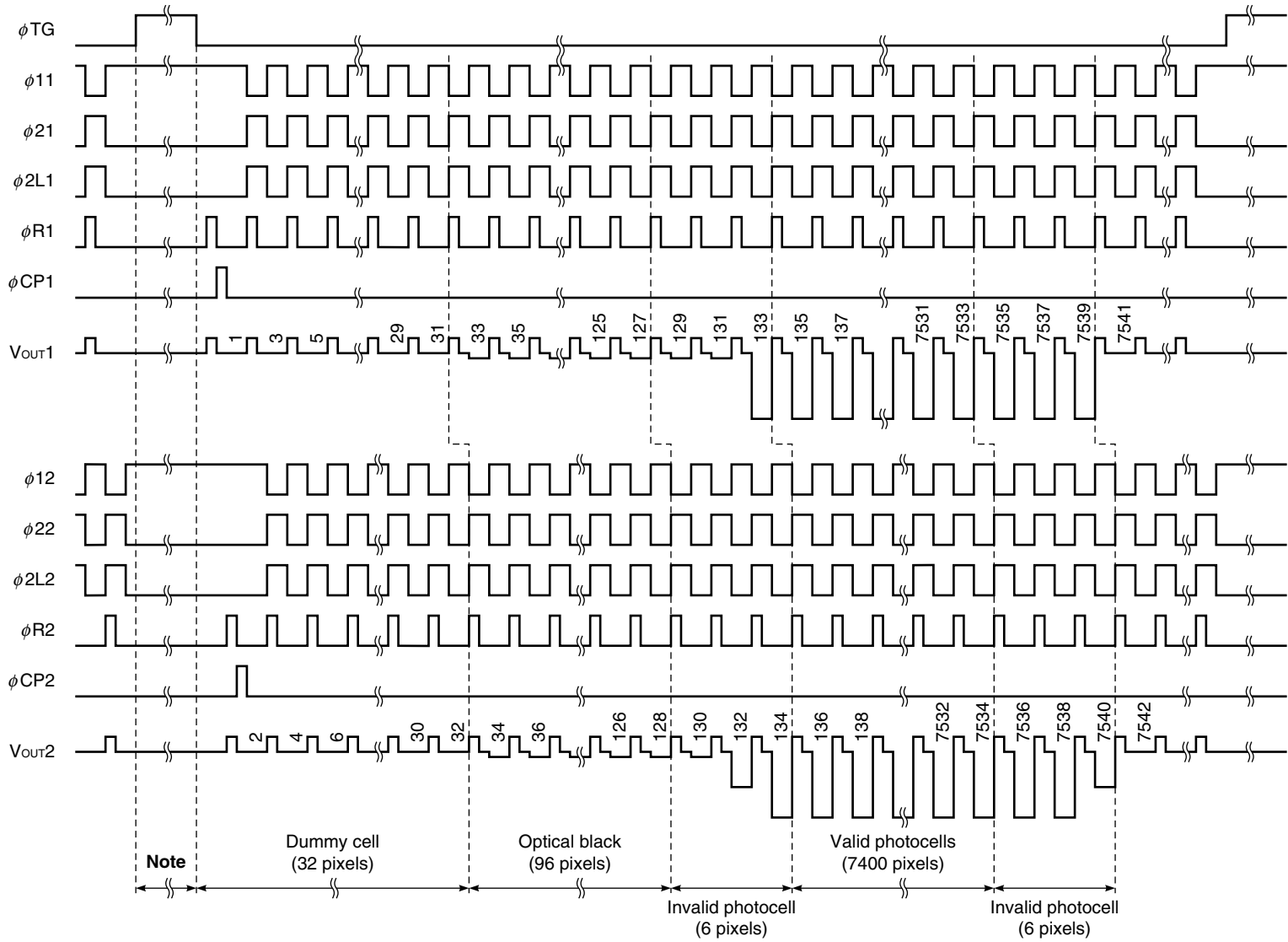

Note Set the ϕ_{R1} , ϕ_{R2} , ϕ_{CP1} and ϕ_{CP2} to low level during this period.

TIMING CHART 3 (Bit clamp mode, In phase operation)

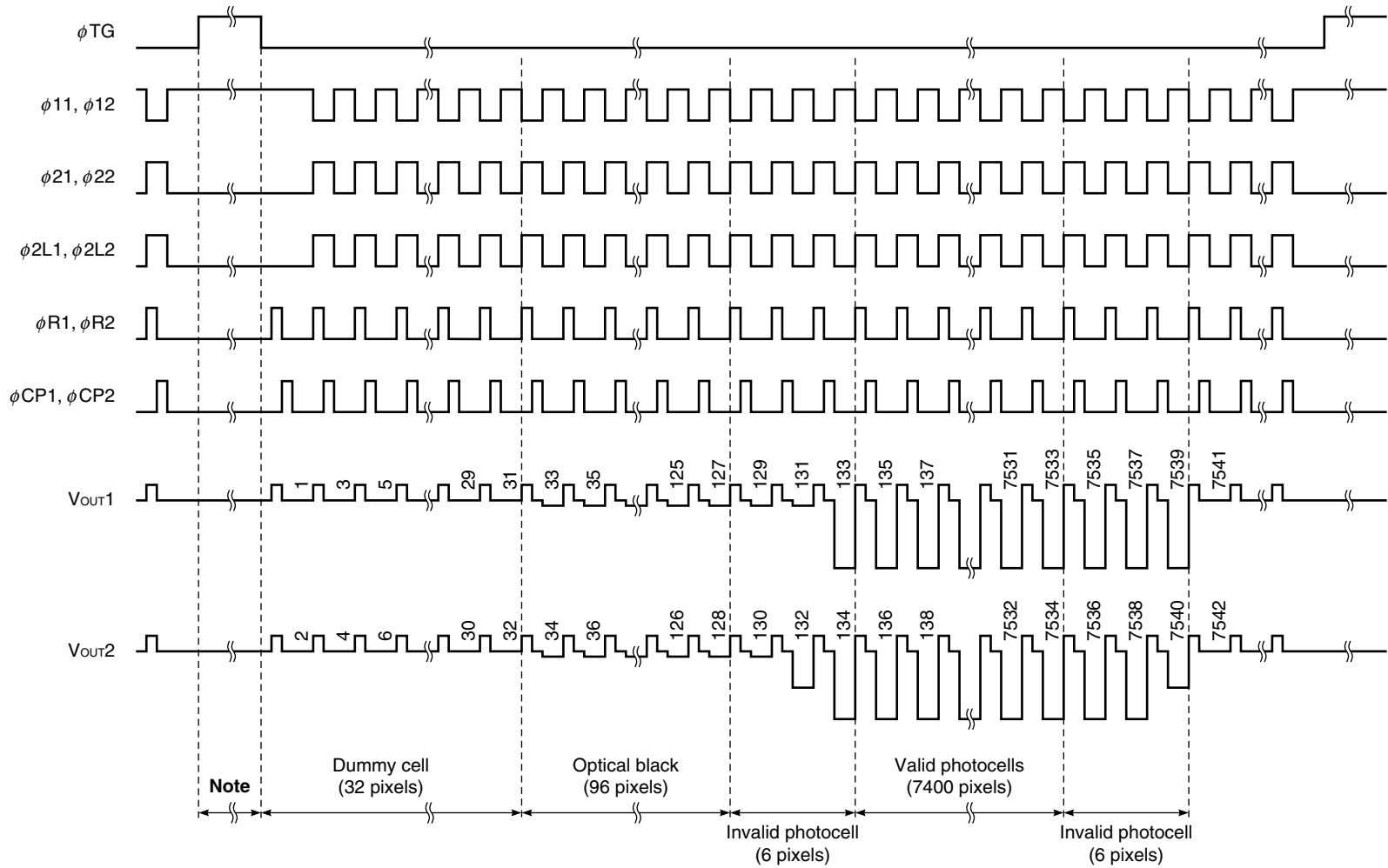

Note Set the ϕ_{R1} , ϕ_{R2} , ϕ_{CP1} and ϕ_{CP2} to low level during this period.

TIMING CHART 4 (Line clamp mode, In phase operation)

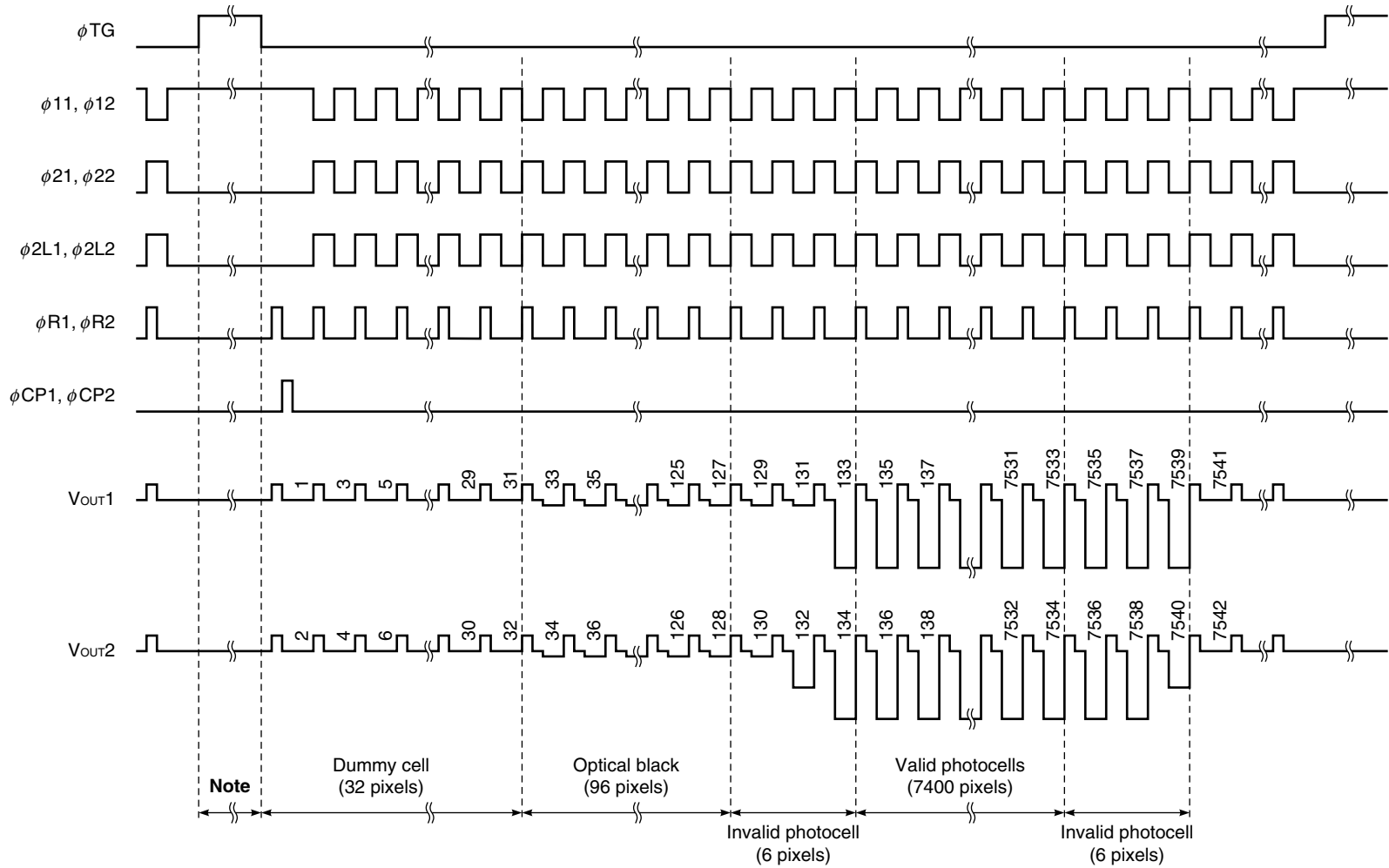

Note Set the $\phi_{R1}, \phi_{R2}, \phi_{CP1}$ and ϕ_{CP2} to low level during this period.

TIMING CHART 5 (Bit clamp mode)

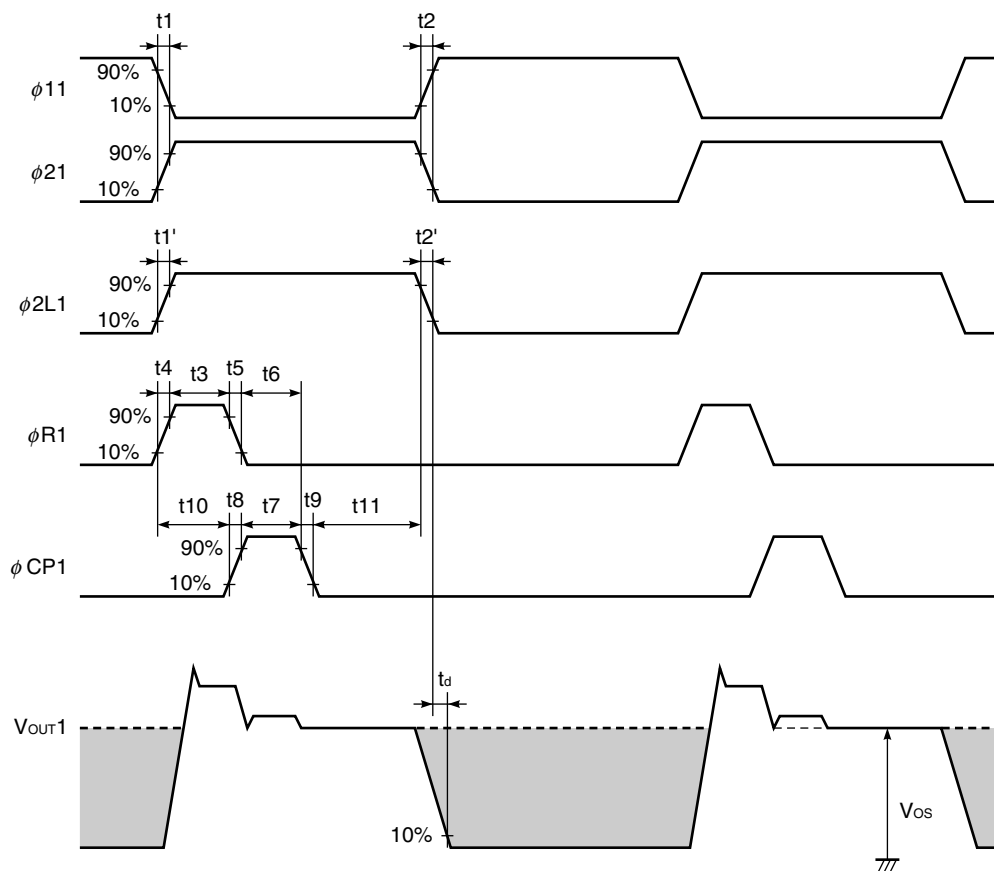

Symbol	MIN.	TYP.	MAX.	Unit
t_1, t_2	0	50	–	ns
t_1', t_2'	0	5	–	ns
t_3	10	125	–	ns
t_4, t_5	0	5	–	ns
t_6	5	125	–	ns
t_7	5	125	–	ns
t_8, t_9	0	5	–	ns
t_{10}	0	125	–	ns
t_{11}	0	250	–	ns

Caution This shows timing chart of V_{OUT1} side (ϕ_{11} , ϕ_{21} , ϕ_{2L1} , ϕ_{R1} , ϕ_{CP1} , V_{OUT1}). The timing chart of V_{OUT2} side (ϕ_{12} , ϕ_{22} , ϕ_{2L2} , ϕ_{R2} , ϕ_{CP2} , V_{OUT2}) is equal.

TIMING CHART 6 (Line clamp mode)

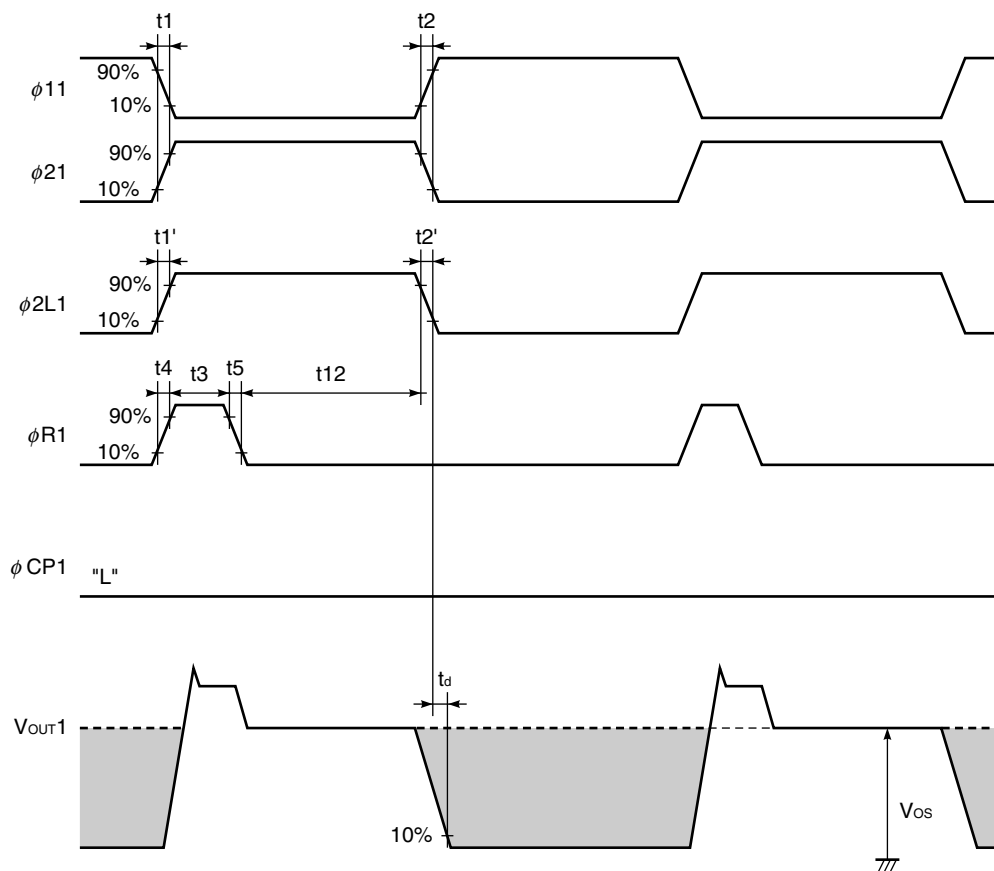

Symbol	MIN.	TYP.	MAX.	Unit
t_1, t_2	0	50	–	ns
t_1', t_2'	0	5	–	ns
t_3	10	125	–	ns
t_4, t_5	0	5	–	ns
t_{12}	5	250	–	ns

Caution This shows timing chart of V_{OUT1} side (ϕ_{11} , ϕ_{21} , ϕ_{2L1} , ϕ_{R1} , ϕ_{CP1} , V_{OUT1}). The timing chart of V_{OUT2} side (ϕ_{12} , ϕ_{22} , ϕ_{2L2} , ϕ_{R2} , ϕ_{CP2} , V_{OUT2}) is equal.

TIMING CHART 7 (Bit clamp mode, Line clamp mode)

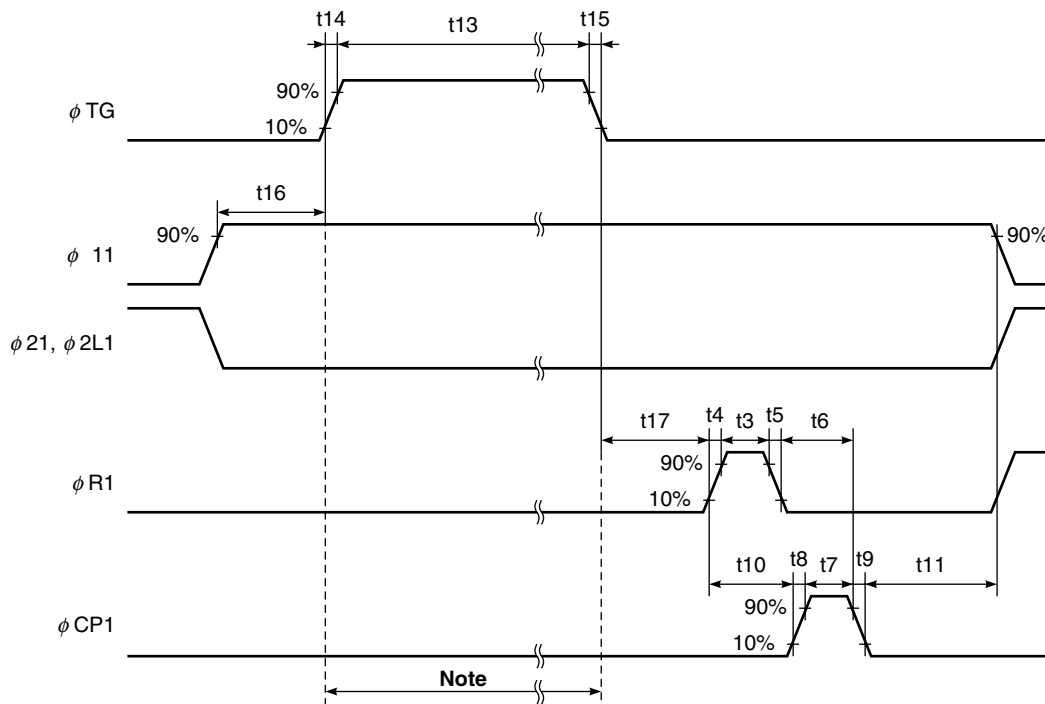

Note Set the ϕ R and ϕ CP to low level during this period.

Symbol	MIN.	TYP.	MAX.	Unit
t3	10	125	–	ns
t4, t5	0	5	–	ns
t6	5	125	–	ns
t7	5	125	–	ns
t8, t9	0	5	–	ns
t10	0	125	–	ns
t11	0	250	–	ns
t13	1000	1500	10000	ns
t14, t15	0	50	–	ns
t16, t17	200	300	10000	ns

Caution This shows timing chart of V_{OUT1} side (ϕ 11, ϕ 21, ϕ 2L1, ϕ R1, ϕ CP1, V_{OUT1}). The timing chart of V_{OUT2} side (ϕ 12, ϕ 22, ϕ 2L2, ϕ R2, ϕ CP2, V_{OUT2}) is equal.

φ11, φ21 cross points

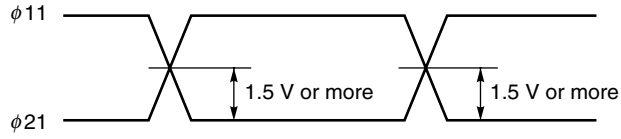

φ11, φ2L1 cross points

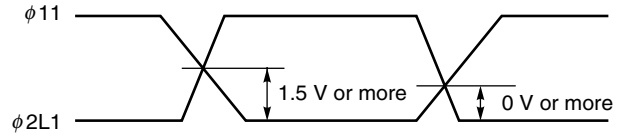

φ12, φ22 cross points

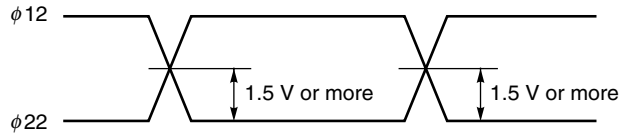

φ12, φ2L2 cross points

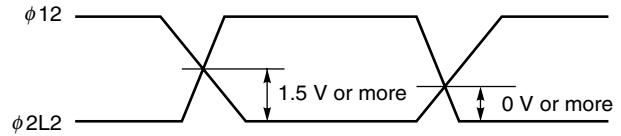

Remark Adjust cross points of (φ11, φ21), (φ11, φ2L1), (φ12, φ22) and (φ12, φ2L2) with input resistance of each pin.

φ11, φ12, φ21, φ22, φ2L1, φ2L2 clock width

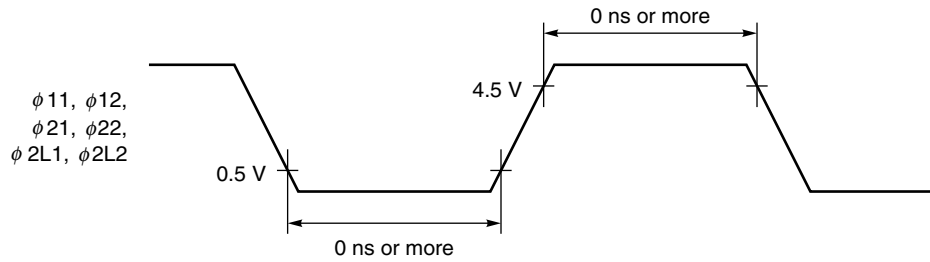

DEFINITIONS OF CHARACTERISTIC ITEMS

1. Saturation voltage : **V_{sat}**
Output signal voltage at which the response linearity is lost.
2. Saturation exposure : **SE**
Product of intensity of illumination (lx) and storage time (s) when saturation of output voltage occurs.
3. Photo response non-uniformity : **PRNU**
The output signal non-uniformity of all the valid pixels when the photosensitive surface is applied with the light of uniform illumination. This is calculated by the following formula.

$$PRNU (\%) = \frac{\Delta x}{\bar{x}} \times 100$$

Δx: maximum of $|x_j - \bar{x}|$

$$\bar{x} = \frac{\sum_{j=1}^{7400} x_j}{7400}$$

x_j: Output voltage of valid pixel number j

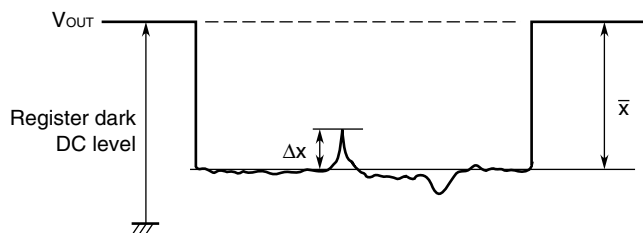

4. Average dark signal : **ADS**
Average output signal voltage of all the valid pixels at light shielding. This is calculated by the following formula.

$$ADS (mV) = \frac{\sum_{j=1}^{7400} d_j}{7400}$$

d_j: Dark signal of valid pixel number j

5. Dark signal non-uniformity : **DSNU**

Absolute maximum of the difference between ADS and voltage of the highest or lowest output pixel of all the valid pixels at light shielding. This is calculated by the following formula.

DSNU (mV): maximum of $|d_j - ADS|$ $|_{j = 1 \text{ to } 7400}$

d_j : Dark signal of valid pixel number j

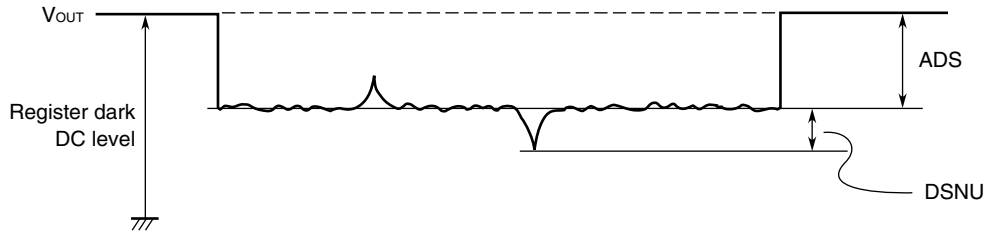

6. Output impedance : **Zo**

Impedance of the output pins viewed from outside.

7. Response : **R**

Output voltage divided by exposure ($I \times s$).

Note that the response varies with a light source (spectral characteristic).

8. Image lag : **IL**

The rate between the last output voltage and the next one after read out the data of a line.

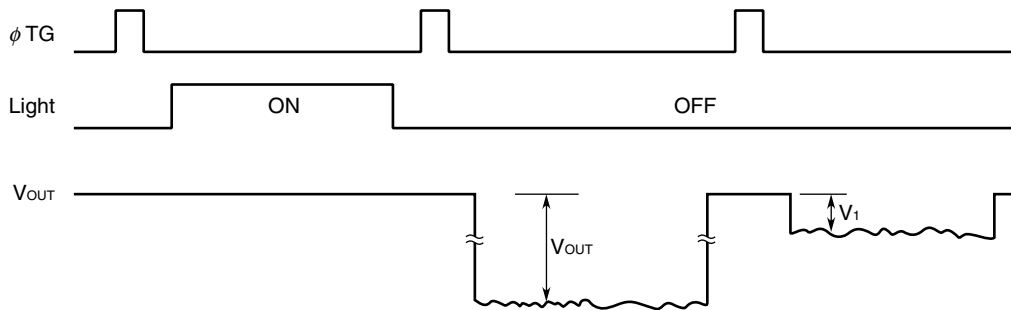

$$IL (\%) = \frac{V_1}{V_{OUT}} \times 100$$

9. Total transfer efficiency : **TTE**

The total transfer rate of CCD analog shift register. This is calculated by the following formula, it is defined by each output.

$$TTE (\%) = (1 - V_b / \text{average output of all the valid pixels}) \times 100$$

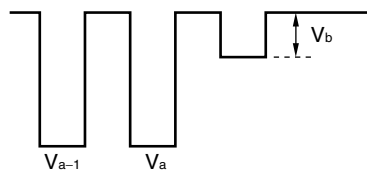

V_{a-1} : The last pixel output - 1 (Odd pixel: 7537th pixel)

V_a : The last pixel output (Odd pixel: 7539th pixel)

V_b : The split pixel output (Odd pixel: 7541st pixel)

10. Register imbalance : **RI**

The rate of the difference between the averages of the output voltage of Odd and Even pixels, against the average output voltage of all the valid pixels.

$$RI (\%) = \frac{\frac{2}{n} \left| \sum_{j=1}^{\frac{n}{2}} (V_{2j-1} - V_{2j}) \right|}{\frac{1}{n} \sum_{j=1}^n V_j} \times 100$$

n : Number of valid pixels
 V_j: Output voltage of each pixel

11. Random noise : **σ**

Random noise σ is defined as the standard deviation of a valid pixel output signal with 100 times (= 100 lines) data sampling at dark (light shielding).

$$\sigma (mV) = \sqrt{\frac{\sum_{i=1}^{100} (V_i - \bar{V})^2}{100}}, \quad \bar{V} = \frac{1}{100} \sum_{i=1}^{100} V_i$$

V_i: A valid pixel output signal among all of the valid pixels

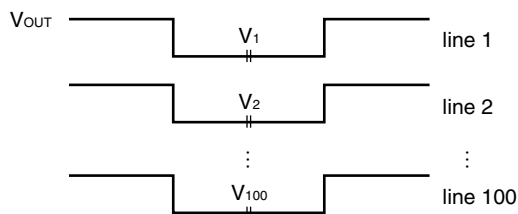

This is measured by the DC level sampling of only the signal level, not by CDS (Correlated Double Sampling).

12. Shot noise : **σ_{shot}**

Shot noise is defined as the standard deviation of a valid pixel output signal with 100 times (= 100 lines) data sampling in the light. This includes the random noise.

The formula is the same with that of random noise.

13. Offset level : V_{os}

DC level of output signal is defined as follows.

14. Reset feed-through noise and peak reset feed-through noise : **RFTN** and **PRFTN**

RFTN is switching noise of ϕ_R and ϕ_{CP} . Reset feed-through noise (RFTN) and peak of RFTN (PRFTN) are defined as follows.

<1> Bit clamp operation

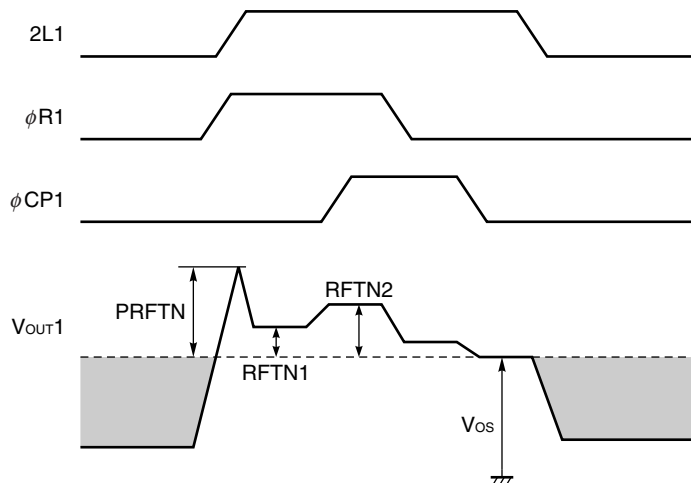

Caution This shows timing of V_{out1} side ($\phi 2L1$, $\phi R1$, $\phi CP1$, V_{out1}). The definition of V_{out2} side ($\phi 2L2$, $\phi R2$, $\phi CP2$, V_{out2}) is equal.

<2> Line clamp operation

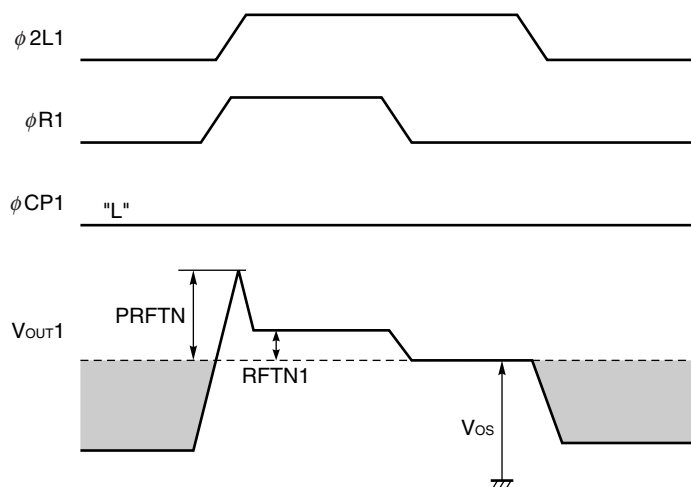

Caution This shows timing of V_{out1} side ($\phi 2L1$, $\phi R1$, $\phi CP1$, V_{out1}). The definition of V_{out2} side ($\phi 2L2$, $\phi R2$, $\phi CP2$, V_{out2}) is equal.

STANDARD CHARACTERISTIC CURVES (Reference Value)

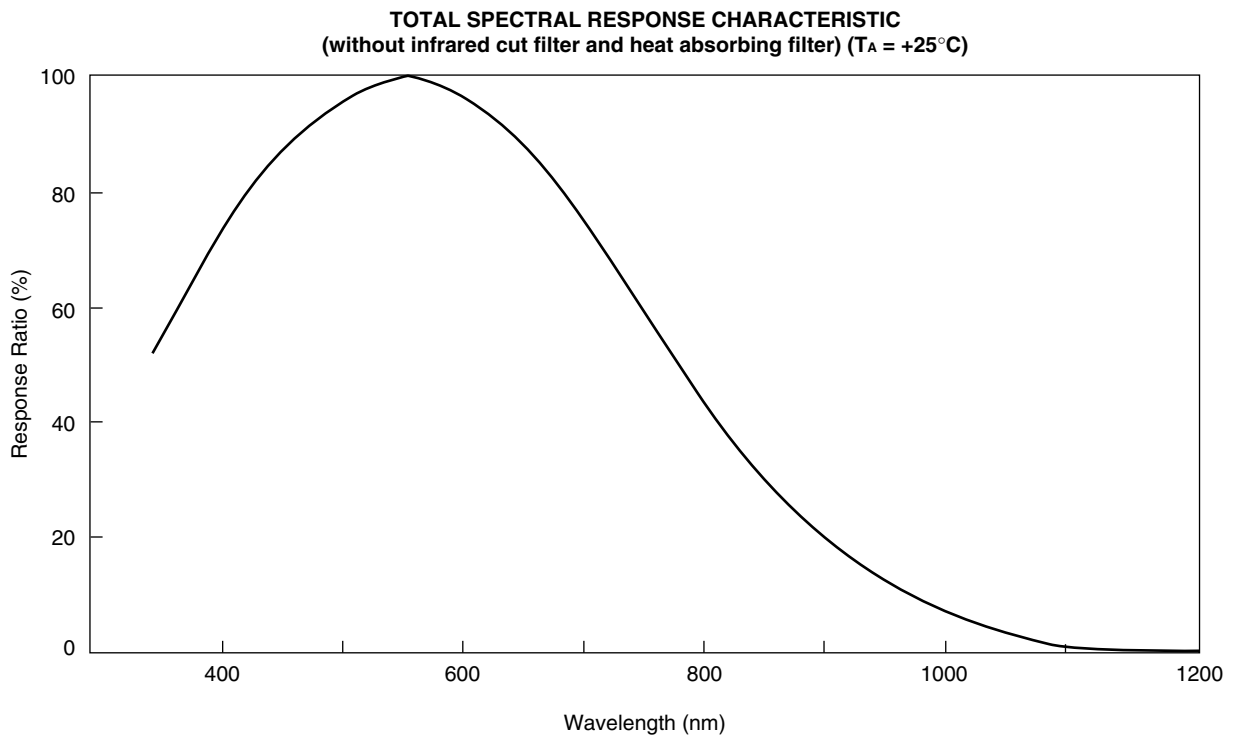
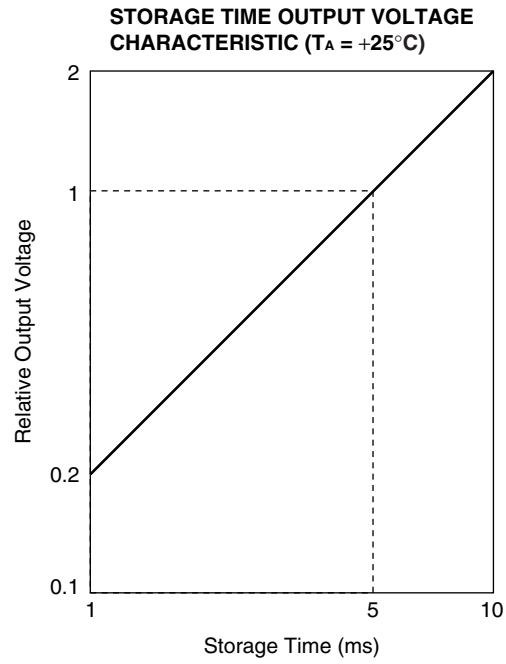
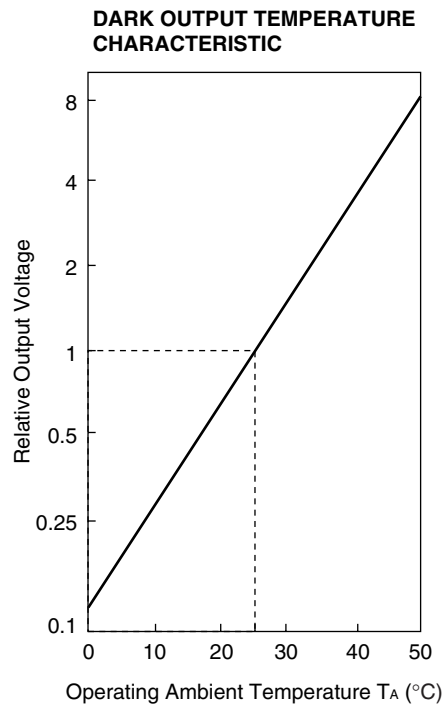

APPLICATION CIRCUIT EXAMPLE

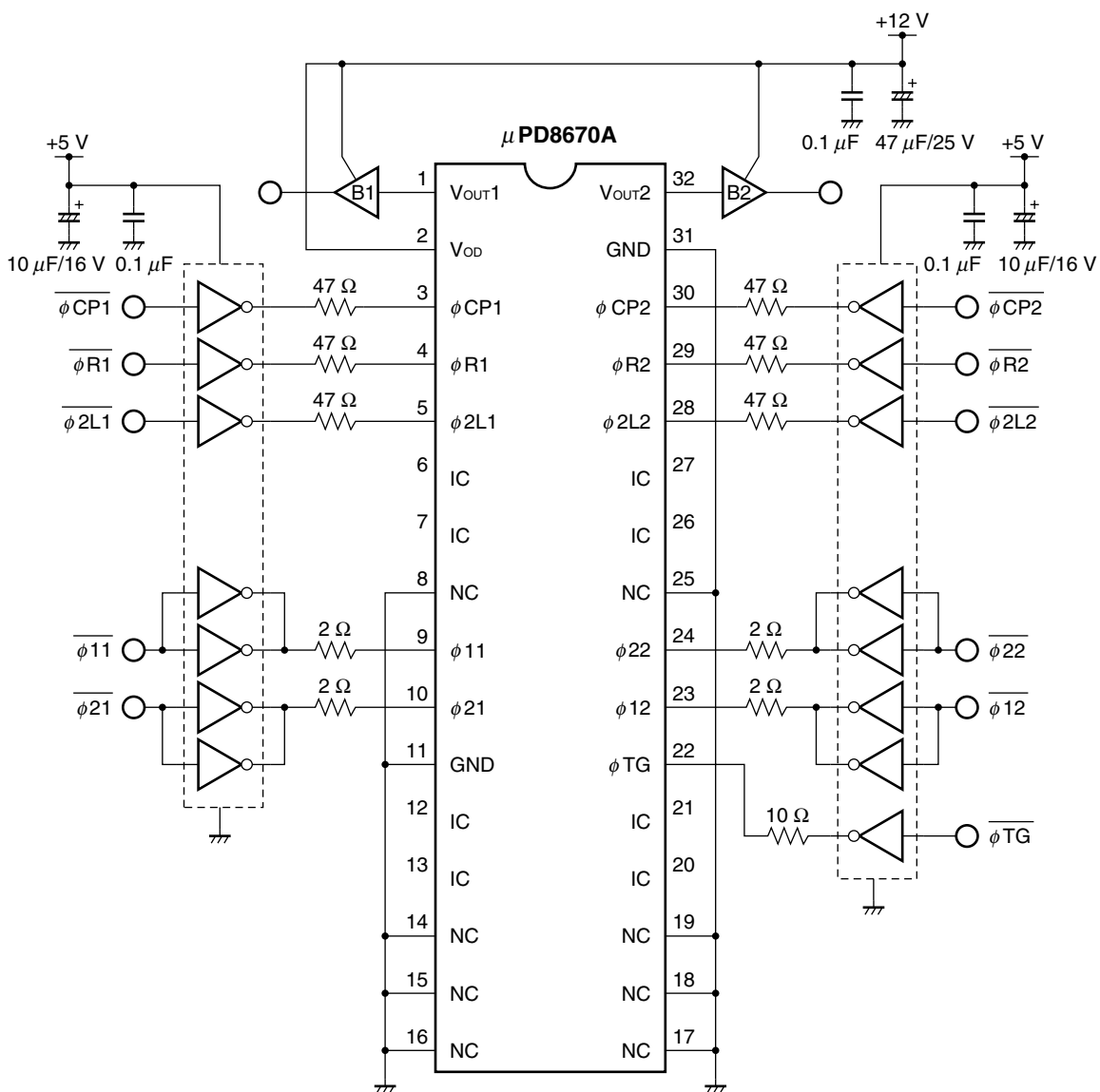

- Cautions**
1. Leave pins 6, 7, 12, 13, 20, 21, 26 and 27 (IC) unconnected.
 2. Connect the No connection pins (NC) to GND.

Remark The inverters shown in the above application circuit example are the 74AC04.

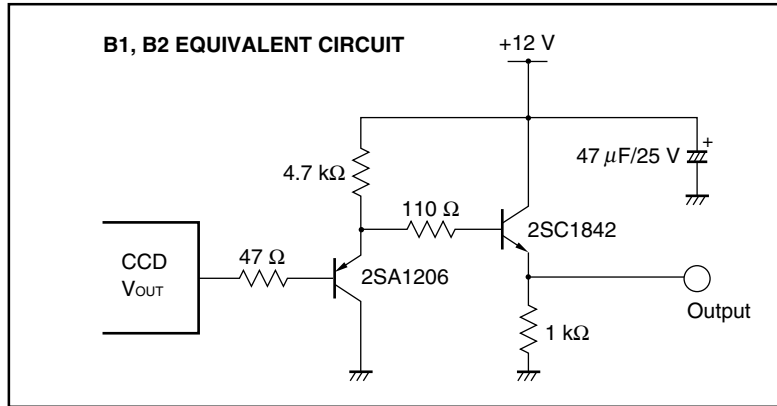

PACKAGE DRAWING

μPD8670CY, μPD8670ACY
 CCD LINEAR IMAGE SENSOR 32-PIN PLASTIC DIP (10.16 mm (400))

(Unit : mm)

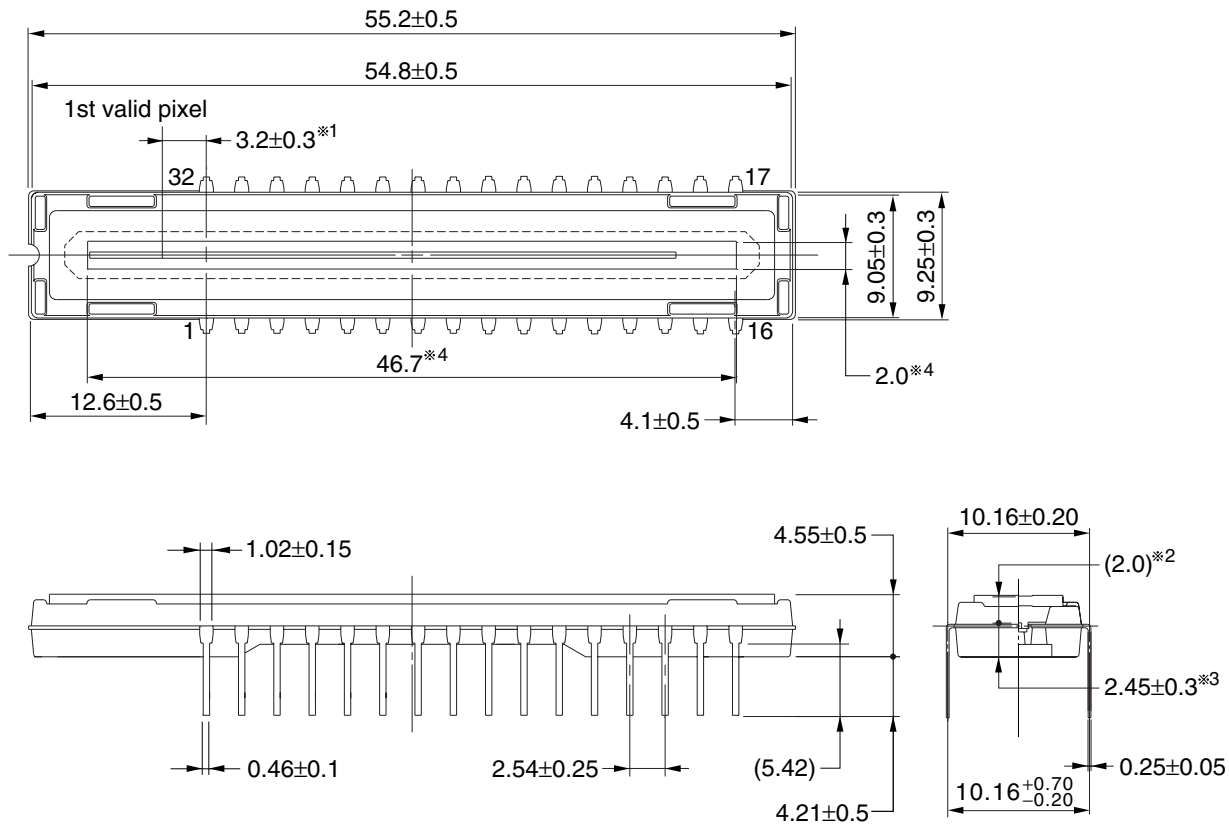

Name	Dimensions	Refractive index
Plastic cap	52.2×6.4×0.8 (0.7 ^{*5})	1.5

- ※1 1st valid pixel ↔ The center of the pin1
- ※2 The surface of the CCD chip ↔ The top of the cap
- ※3 The bottom of the package ↔ The surface of the CCD chip
- ※4 Mirror finished surface
- ※5 Thickness of mirror finished surface

32C-1CCD-PKG10-2

RECOMMENDED SOLDERING CONDITIONS

When soldering this product, it is highly recommended to observe the conditions as shown below.

If other soldering processes are used, or if the soldering is performed under different conditions, please make sure to consult with our sales offices.

Type of Through-hole Device

μPD8670ACY : CCD linear image sensor 32-pin plastic DIP (10.16 mm (400))

Process	Conditions
Partial heating method	Pin temperature : 350°C or below, Heat time : 3 seconds or less (per pin)

- Cautions**
- 1. During assembly care should be taken to prevent solder or flux from contacting the plastic cap. The optical characteristics could be degraded by such contact.**
 - 2. Soldering by the solder flow method may have deleterious effects on prevention of plastic cap soiling and heat resistance. So the method cannot be guaranteed.**

NOTES ON HANDLING THE PACKAGES

① DUST AND DIRT PROTECTING

The optical characteristics of the CCD will be degraded if the cap is scratched during cleaning. Don't either touch plastic cap surface by hand or have any object come in contact with plastic cap surface. Should dirt stick to a plastic cap surface, blow it off with an air blower. For dirt stuck through electricity ionized air is recommended. And if the plastic cap surface is grease stained, clean with our recommended solvents.

○ CLEANING THE PLASTIC CAP

Care should be taken when cleaning the surface to prevent scratches. We recommend cleaning the cap with a soft cloth moistened with one of the recommended solvents below. Excessive pressure should not be applied to the cap during cleaning. If the cap requires multiple cleanings it is recommended that a clean surface or cloth be used.

○ RECOMMENDED SOLVENTS

The following are the recommended solvents for cleaning the CCD plastic cap. Use of solvents other than these could result in optical or physical degradation in the plastic cap. Please consult your sales office when considering an alternative solvent.

Solvents	Symbol
Ethyl Alcohol	EtOH
Methyl Alcohol	MeOH
Isopropyl Alcohol	IPA
N-methyl Pyrrolidone	NMP

② MOUNTING OF THE PACKAGE

The application of an excessive load to the package may cause the package to warp or break, or cause chips to come off internally. Particular care should be taken when mounting the package on the circuit board. Don't have any object come in contact with plastic cap. You should not reform the lead frame. We recommended to use a IC-inserter when you assemble to PCB.

Also, be care that the any of the following can cause the package to crack or dust to be generated.

1. Applying heat to the external leads for an extended period of time with soldering iron.
2. Applying repetitive bending stress to the external leads.
3. Rapid cooling or heating

③ OPERATE AND STORAGE ENVIRONMENTS

Operate in clean environments. CCD image sensors are precise optical equipment that should not be subject to mechanical shocks. Exposure to high temperatures or humidity will affect the characteristics. So avoid storage or usage in such conditions.

Keep in a case to protect from dust and dirt. Dew condensation may occur on CCD image sensors when the devices are transported from a low-temperature environment to a high-temperature environment. Avoid such rapid temperature changes.

For more details, refer to our document "Review of Quality and Reliability Handbook" (C12769E)

④ ELECTROSTATIC BREAKDOWN

CCD image sensor is protected against static electricity, but destruction due to static electricity is sometimes detected. Before handling be sure to take the following protective measures.

1. Ground the tools such as soldering iron, radio cutting pliers of or pincer.
2. Install a conductive mat or on the floor or working table to prevent the generation of static electricity.
3. Either handle bare handed or use non-chargeable gloves, clothes or material.
4. Ionized air is recommended for discharge when handling CCD image sensor.
5. For the shipment of mounted substrates, use box treated for prevention of static charges.
6. Anyone who is handling CCD image sensors, mounting them on PCBs or testing or inspecting PCBs on which CCD image sensors have been mounted must wear anti-static bands such as wrist straps and ankle straps which are grounded via a series resistance connection of about 1 MΩ.

[NOTE]

NOTES FOR CMOS DEVICES

① VOLTAGE APPLICATION WAVEFORM AT INPUT PIN

Waveform distortion due to input noise or a reflected wave may cause malfunction. If the input of the CMOS device stays in the area between V_{IL} (MAX) and V_{IH} (MIN) due to noise, etc., the device may malfunction. Take care to prevent chattering noise from entering the device when the input level is fixed, and also in the transition period when the input level passes through the area between V_{IL} (MAX) and V_{IH} (MIN).

② HANDLING OF UNUSED INPUT PINS

Unconnected CMOS device inputs can be cause of malfunction. If an input pin is unconnected, it is possible that an internal input level may be generated due to noise, etc., causing malfunction. CMOS devices behave differently than Bipolar or NMOS devices. Input levels of CMOS devices must be fixed high or low by using pull-up or pull-down circuitry. Each unused pin should be connected to V_{DD} or GND via a resistor if there is a possibility that it will be an output pin. All handling related to unused pins must be judged separately for each device and according to related specifications governing the device.

③ PRECAUTION AGAINST ESD

A strong electric field, when exposed to a MOS device, can cause destruction of the gate oxide and ultimately degrade the device operation. Steps must be taken to stop generation of static electricity as much as possible, and quickly dissipate it when it has occurred. Environmental control must be adequate. When it is dry, a humidifier should be used. It is recommended to avoid using insulators that easily build up static electricity. Semiconductor devices must be stored and transported in an anti-static container, static shielding bag or conductive material. All test and measurement tools including work benches and floors should be grounded. The operator should be grounded using a wrist strap. Semiconductor devices must not be touched with bare hands. Similar precautions need to be taken for PW boards with mounted semiconductor devices.

④ STATUS BEFORE INITIALIZATION

Power-on does not necessarily define the initial status of a MOS device. Immediately after the power source is turned ON, devices with reset functions have not yet been initialized. Hence, power-on does not guarantee output pin levels, I/O settings or contents of registers. A device is not initialized until the reset signal is received. A reset operation must be executed immediately after power-on for devices with reset functions.

⑤ POWER ON/OFF SEQUENCE

In the case of a device that uses different power supplies for the internal operation and external interface, as a rule, switch on the external power supply after switching on the internal power supply. When switching the power supply off, as a rule, switch off the external power supply and then the internal power supply. Use of the reverse power on/off sequences may result in the application of an overvoltage to the internal elements of the device, causing malfunction and degradation of internal elements due to the passage of an abnormal current.

The correct power on/off sequence must be judged separately for each device and according to related specifications governing the device.

⑥ INPUT OF SIGNAL DURING POWER OFF STATE

Do not input signals or an I/O pull-up power supply while the device is not powered. The current injection that results from input of such a signal or I/O pull-up power supply may cause malfunction and the abnormal current that passes in the device at this time may cause degradation of internal elements. Input of signals during the power off state must be judged separately for each device and according to related specifications governing the device.

- **The information in this document is current as of August, 2004. The information is subject to change without notice. For actual design-in, refer to the latest publications of NEC Electronics data sheets or data books, etc., for the most up-to-date specifications of NEC Electronics products. Not all products and/or types are available in every country. Please check with an NEC Electronics sales representative for availability and additional information.**

- No part of this document may be copied or reproduced in any form or by any means without the prior written consent of NEC Electronics. NEC Electronics assumes no responsibility for any errors that may appear in this document.
- NEC Electronics does not assume any liability for infringement of patents, copyrights or other intellectual property rights of third parties by or arising from the use of NEC Electronics products listed in this document or any other liability arising from the use of such products. No license, express, implied or otherwise, is granted under any patents, copyrights or other intellectual property rights of NEC Electronics or others.
- Descriptions of circuits, software and other related information in this document are provided for illustrative purposes in semiconductor product operation and application examples. The incorporation of these circuits, software and information in the design of a customer's equipment shall be done under the full responsibility of the customer. NEC Electronics assumes no responsibility for any losses incurred by customers or third parties arising from the use of these circuits, software and information.
- While NEC Electronics endeavors to enhance the quality, reliability and safety of NEC Electronics products, customers agree and acknowledge that the possibility of defects thereof cannot be eliminated entirely. To minimize risks of damage to property or injury (including death) to persons arising from defects in NEC Electronics products, customers must incorporate sufficient safety measures in their design, such as redundancy, fire-containment and anti-failure features.
- NEC Electronics products are classified into the following three quality grades: "Standard", "Special" and "Specific".

The "Specific" quality grade applies only to NEC Electronics products developed based on a customer-designated "quality assurance program" for a specific application. The recommended applications of an NEC Electronics product depend on its quality grade, as indicated below. Customers must check the quality grade of each NEC Electronics product before using it in a particular application.

"Standard": Computers, office equipment, communications equipment, test and measurement equipment, audio and visual equipment, home electronic appliances, machine tools, personal electronic equipment and industrial robots.

"Special": Transportation equipment (automobiles, trains, ships, etc.), traffic control systems, anti-disaster systems, anti-crime systems, safety equipment and medical equipment (not specifically designed for life support).

"Specific": Aircraft, aerospace equipment, submersible repeaters, nuclear reactor control systems, life support systems and medical equipment for life support, etc.

The quality grade of NEC Electronics products is "Standard" unless otherwise expressly specified in NEC Electronics data sheets or data books, etc. If customers wish to use NEC Electronics products in applications not intended by NEC Electronics, they must contact an NEC Electronics sales representative in advance to determine NEC Electronics' willingness to support a given application.

(Note)

- (1) "NEC Electronics" as used in this statement means NEC Electronics Corporation and also includes its majority-owned subsidiaries.
- (2) "NEC Electronics products" means any product developed or manufactured by or for NEC Electronics (as defined above).