

US2A THRU US2M

GLASS PASSIVATED JUNCTION
ULTRA FAST RECOVERY RECTIFIER
Reverse Voltage: 50 to 1000 Volts
Forward Current: 2.0Ampere

FEATURES

- Plastic package has Underwriters Laboratory Flammability Classification 94V-0
- Glass passivated junction
- Low forward voltage drop
- High current capability, High reliability
- Low power loss, high efficiency
- High surge current capability
- High speed switching, Low leakage
- High temperature soldering guaranteed:260°C/10 seconds at terminals
- Component in accordance to RoHS 2011/65/EU



SMA(DO-214AC)

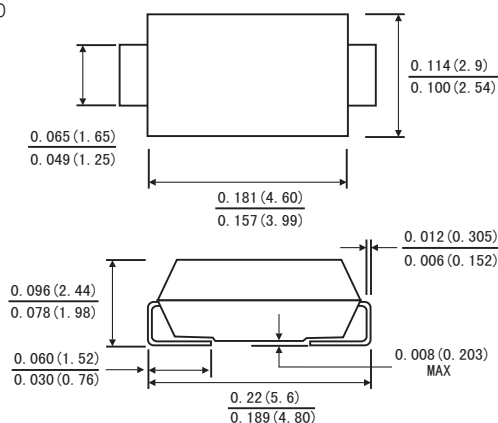

MECHANICAL DATA

- Case: JEDEC DO-214AC molded plastic over glass passivated chip
- Terminals: Solder plated, solderable per MIL-STD-750, Method 2026
- Polarity: Color band denotes cathode end
- Weight: 0.002 oz., 0.064 g

MAXIMUM RATINGS AND ELECTRICAL CHARACTERISTICS

(Rating at 25°C ambient temperature unless otherwise specified. Single phase ,half wave ,60Hz,resistive or inductive load. For capacitive load, derate current by 20%.)

	Symbols	US2A	US2B	US2D	US2F	US2G	US2J	US2K	US2M	Units	
Maximum Recurrent Peak Reverse Voltage	V _{RRM}	50	100	200	300	400	600	800	1000	Volts	
Maximum RMS Voltage	V _{RMS}	35	70	140	210	280	420	560	700	Volts	
Maximum DC Blocking Voltage	V _{DC}	50	100	200	300	400	600	800	1000	Volts	
Maximum Average Forward Rectified Current	I(AV)	2.0								Amp	
Peak Forward Surge Current 8.3ms single half sine-wave superimposed on rated load (JEDEC method)	I _{FSM}	50								Amps	
Maximum Instantaneous Forward Voltage at 2.0 A	V _F	1.0			1.3		1.7			Volts	
Maximum DC Reverse Current at rated DC blocking voltage	T _A =25°C	5.0								μA	
	T _A =100°C	50									
Maximum reverse recovery time(Note1)	T _{rr}	50					75				ns
Typical junction capacitance(Note2)	C _J	15								pF	
Operating junction and storage temperature range	T _J T _{STG}	-50 to+150								°C	

Note: 1.Test conditions: I_F=0.5A,I_R=1.0A,I_{RR}=0.25A.

2.Measured at 1MHz and applied reverse voltage of 4.0 Volts.

RATINGS AND CHARACTERISTIC CURVES US2A THRU US2M

FIG.1-TEST CIRCUIT DIAGRAM AND REVERSE RECOVERY TIME CHARACTERISTIC

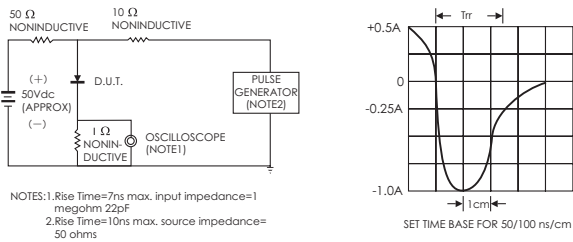

FIG.2-TYPICAL FORWARD CURRENT DERATING CURVE

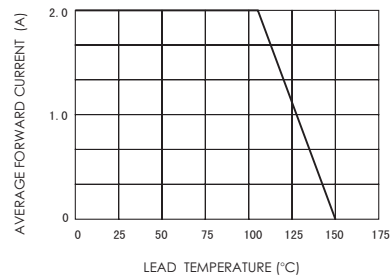

FIG.3-TYPICAL INSTANTANEOUS FORWARD CHARACTERISTICS

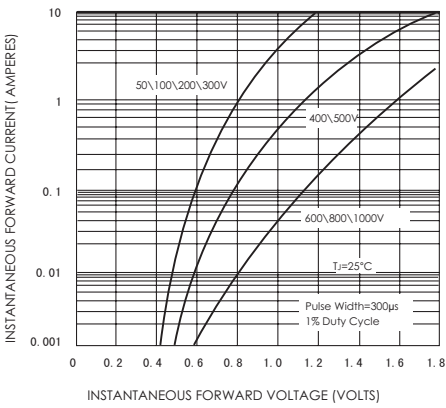

FIG.4-TYPICAL REVERSE CHARACTERISTICS

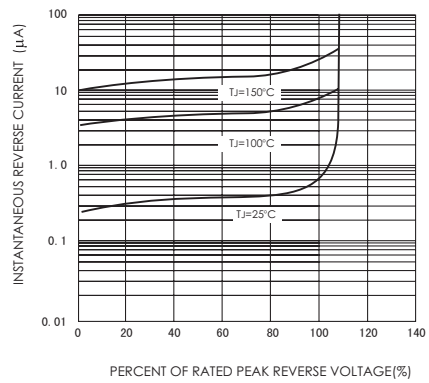

FIG.5-MAXIMUM NON-REPETITIVE FORWARD SURGE CURRENT

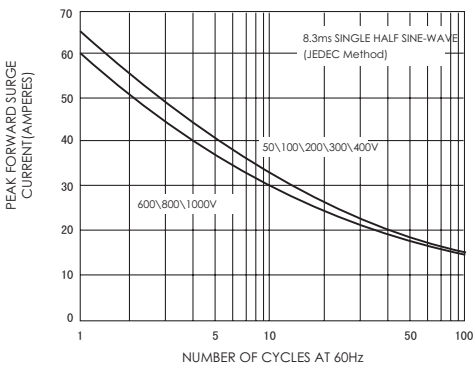

FIG.6-TYPICAL JUNCTION CAPACITANCE

